

# Technical Documentation

---



Universal Signal Interface  
Converter

## **USIC**

Document: 0198441113263

Edition: V1.05, 12.2006

---

## Important information

The drive systems described here are products for general use that conform to the state of the art in technology and are designed to prevent any dangers. However, drives and drive controllers that are not specifically designed for safety functions are not approved for applications where the functioning of the drive could endanger persons. The possibility of unexpected or unbraked movements can never be totally excluded without additional safety equipment. For this reason personnel must never be in the danger zone of the drives unless additional suitable safety equipment prevents any personal danger. This applies to operation of the machine during production and also to all service and maintenance work on drives and the machine. The machine design must ensure personal safety. Suitable measures for prevention of property damage are also required.

See safety section for additional critical instructions.

### **Not all product variants are available in all countries.**

Please consult the current catalogue for information on the availability of product variants.

We reserve the right to make changes during the course of technical developments.

All details provided are technical data and not promised characteristics.

In general, product names must be considered to be trademarks of the respective owners, even if not specifically identified as such.

## Table of Contents

<b>Important information</b> . . . . .	<b>-2</b>
<b>Table of Contents</b> . . . . .	<b>-3</b>
<b>Writing conventions and symbols</b> . . . . .	<b>-5</b>
<b>1 Introduction</b>	
1.1 Functional description . . . . .	1-1
1.2 Directives and standards . . . . .	1-1
1.3 Declaration of conformity . . . . .	1-2
<b>2 Safety</b>	
2.1 Qualification of personnel . . . . .	2-1
2.2 Intended use . . . . .	2-1
2.3 General safety instructions . . . . .	2-2
<b>3 Technical Data</b>	
3.1 Environmental conditions . . . . .	3-1
3.2 Mechanical data . . . . .	3-1
3.3 Electrical Data . . . . .	3-2
3.3.1 Supply voltage . . . . .	3-2
3.3.2 Electrical characteristics of the signal inputs . . . . .	3-2
3.3.3 Electrical characteristics of the signal outputs . . . . .	3-2
<b>4 Installation</b>	
4.1 Electromagnetic compatibility, EMC . . . . .	4-1
4.2 Mechanical installation . . . . .	4-2
4.3 Electrical installation . . . . .	4-3
4.3.1 Overview of connections . . . . .	4-3
4.3.2 Power supply connection . . . . .	4-5
4.3.3 Connection of signals . . . . .	4-6
4.3.4 Application examples . . . . .	4-7
4.3.5 Checking installation . . . . .	4-8
<b>5 Commissioning</b>	
<b>6 Service, maintenance and disposal</b>	
6.1 Service address . . . . .	6-1
6.2 Maintenance . . . . .	6-1
6.3 Shipping, storage, disposal . . . . .	6-1

**7 Glossary**

7.1 Terms and Abbreviations . . . . . 7-1

**8 Index**

## Writing conventions and symbols

*Work steps* If work steps must be carried out in sequence, they are shown as follows:

- Special prerequisites for the following work steps
- ▶ Step 1
- ◁ Important response to this work step
- ▶ Step 2

If a response to a work step is specified, this will inform you that the step has been carried out correctly.

Unless otherwise stated, the individual instruction steps must be carried in the given sequence.

*Lists* Lists can be sorted alphanumerically or by priority. Lists are structured as follows:

- Point 1
- Point 2
  - Subpoint to 2
  - Subpoint to 2
- Point 3

*Making work easier* Information on making work easier can be found at this symbol:



*This offers supplementary information on making work easier.  
See the chapter on safety for an explanation of the safety instructions.*



# 1 Introduction

## 1.1 Functional description

The USIC (Universal Signal Interface Converter) is an interface adapter, which is used as a universal adapter for a pulse/direction interface to a master controller (e.g. PLC).

USIC is recommended in the following cases:

- If 24V signals are to be connected to 5V inputs
- If it is necessary to isolate the signals electrically (e.g. incorrect reference potential, serious interference in the area)
- If signals with an open collector are connected over distances greater than 3m or the frequency is greater than 50kHz

USIC has the following features:

- 24V or 5V inputs (optocoupler) are available as required.
- Actuation signals are adapted for products with inputs that comply with RS422.
- Electrical isolation of signals

A 24V power supply (corresponding to PELV) must be provided by the customer.

## 1.2 Directives and standards

*Relevant standards* IEC 60204-1: Electrical equipment of machines, General requirements  
IEC 60529: IP degrees of protection

## 1.3 Declaration of conformity

<b><u>EC Declaration of Conformity</u></b>		
<b><u>Year 2005</u></b>		
<input type="checkbox"/> according to EC Directive Low Voltage 73/23/EEC, changed by CE Marking Directive 93/68/EEC <input type="checkbox"/> according to EC Directive on Machinery 98/37/EEC <input checked="" type="checkbox"/> according to EC Directive EMC 2004/108/EEC		
<p>We declare that the products listed below meet the requirements of the mentioned EC Directives with respect to design, construction and version distributed by us. This declaration becomes invalid with any modification on the products not authorized by us.</p>		
Designation:	Accessories Interface Adapter	
Type:	USIC	
Product number:	0162501532005	
Applied harmonized standards, especially:	EN 50178:1998 EN 61800-3:2001, second environment according to Berger Lahr EMC test conditions	
Applied national standards and technical specifications, especially:	Berger Lahr EMC test conditions 200.47-01 EN Product documentation	
Company stamp:	<b>Berger Lahr GmbH &amp; Co. KG</b> Postfach 11 80 · D-77901 Lahr Breslauer Str. 7 · D-77933 Lahr	
Date/ Signature:	21 February 2005	
Name/ Department:	Wolfgang Brandstätter/R & D Drive Systems	



## 2 Safety

### 2.1 Qualification of personnel

Only technicians who are familiar with and understand the contents of this manual and the other relevant manuals are authorised to work on and with this drive system. The technicians must be able to detect potential dangers that may be caused by setting parameters, changing parameter values and generally by the mechanical, electrical and electronic equipment.

The technicians must have sufficient technical training, knowledge and experience to recognise and avoid dangers.

The technicians must be familiar with the relevant standards, regulations and safety regulations that must be observed when working on the drive system.

### 2.2 Intended use

The drive systems described here are products for general use that conform to the state of the art in technology and are designed to prevent any dangers. However, drives and drive controllers that are not specifically designed for safety functions are not approved for applications where the functioning of the drive could endanger persons. The possibility of unexpected or unbraked movements can never be totally excluded without additional safety equipment. For this reason personnel must never be in the danger zone of the drives unless additional suitable safety equipment prevents any personal danger. This applies to operation of the machine during production and also to all service and maintenance work on drives and the machine. The machine design must ensure personal safety. Suitable measures for prevention of property damage are also required.

In the system configuration described the drive systems must be used in industrial applications only and must have a fixed connection only.

In all cases the applicable safety regulations and the specified operating conditions, such as environmental conditions and specified technical data, must be observed.

The drive system must not be commissioned and operated until completion of installation in accordance with the EMC regulations and the specifications in this manual.

To prevent personal injury and damage to property damaged drive systems must not be installed or operated.

Changes and modifications of the drive systems are not permitted and if made all no warranty and liability will be accepted.

The drive system must be operated only with the specified wiring and approved accessories. In general, use only original accessories and spare parts.

The drive systems must not be operated in an environment subject to explosion hazard (ex area).

## 2.3 General safety instructions

### **▲ WARNING**

#### **Loss of control over controller**

- Observe the accident prevention regulations. (For USA see also NEMA ICS1.1 and NEMA ICS7.1)
- The system manufacturer must take the potential error possibilities of the signals and the critical functions into account to ensure a safe status during and after errors. Some examples are: emergency stop, final position limitation, power failure and restart.
- The assessment of error possibilities must also include unexpected delays and the failure of signals or functions.
- Suitable redundant control paths must be in place for dangerous functions.
- Check that measures taken are effective.

**Failure to follow these instructions can result in death or serious injury.**

### 3 Technical Data

#### 3.1 Environmental conditions

*ambient operating temperature*

Temperature <sup>1)</sup>	°C	0 ... +50
---------------------------	----	-----------

1) no icing

*Ambient climate for transport and storage*

The environment during transport and storage must be dry and dust-free. The maximum oscillation and shock stress must be within the specified limits. The bearing and transport temperature must remain within the specified range.

Temperature	°C	-25 ... +70
-------------	----	-------------

*Pollution degree*

Pollution degree	2
------------------	---

*Relative humidity*

The relative humidity is allowed as follows:

rel. humidity	conforming to IEC60721-3-3, Class 3K3, 5% ... 85%, no condensation permitted
---------------	--

*Vibration and shock loading*

The strength during oscillation stress on the units corresponds to EN 50178 Section 9.4.3.2 and IEC 61131-2 Section 6.3.5.1.

Oscillation and vibration	Conforming to IEC/EN 60068-2-6: 1.5 mm peak to peak from 3 ... 13 Hz, 1 gn from 13 ... 150 Hz
---------------------------	--

Shock loading	15 gn for 11 ms conforming to IEC/EN 60068-2-27
---------------	---

#### 3.2 Mechanical data

Dimensions (B*H*T)	[mm]	68 x 73 x 38
--------------------	------	--------------

Degree of protection to EN 60529	IP00
----------------------------------	------

### 3.3 Electrical Data

#### 3.3.1 Supply voltage

Max. power supply voltage		[V <sub>DC</sub> ]	30
Min. power supply voltage		[V <sub>DC</sub> ]	20
Power consumption	min.	[mA]	15
	max.	[mA]	150
Ripple voltage		[V <sub>pp</sub> ]	<2

The power supply voltage input is protected against polarity reversal.

#### 3.3.2 Electrical characteristics of the signal inputs

Resistor network	Level
plugged in (75Ω, standard from the factory)	5 V level (U <sub>S</sub> = 2.5V ... 5.25V)
not plugged in	24 V level (U <sub>S</sub> = 20V ... 30V)

PULSE/ $\overline{\text{PULSE}}$ , DIR/ $\overline{\text{DIR}}$ , ENABLE/ $\overline{\text{ENABLE}}$ , PWM/ $\overline{\text{PWM}}$  and STEP2\_INV/ $\overline{\text{STEP2\_INV}}$  are optically isolated and safe against polarity reversal. Note the signal voltage level (5V, 24V).

		5V (CN1 only)	24V (at CN1 or CN3)
Max. input voltage]	[V]	5.25	30
Turn-on point U <sub>E</sub>	[V]	2.5	20
Turn-off point U <sub>A</sub>	[V]	0.4	3
Typ. input current at rated voltage	[mA]	10	10

#### 3.3.3 Electrical characteristics of the signal outputs

*Open collector outputs*  $\overline{\text{ACTIVE2\_OUT}}$  and  $\overline{\text{FAULT\_OUT}}$  are each open collector outputs against 0VDC at CN1.

ACTIVE2\_OUT and FAULT\_OUT are each open collector outputs against +24VDC at CN3 (plug-in terminals).

These signal outputs are short-circuit resistant.

Max. output voltage	[V]	≤30
Max. output current	[mA]	50

*RS422 outputs* The RS422 outputs comply with the standard and are short-circuit resistant.

## 4 Installation

### 4.1 Electromagnetic compatibility, EMC

#### **▲ WARNING**

##### **Interference with signals and devices**

Distorted signals can cause unpredictable device responses.

- Install the wiring in accordance with the EMC requirements.
- Check compliance with the EMC requirements, particularly in an environment subject to strong interference.

**Failure to follow these instructions can result in death, serious injury or equipment damage.**

An EMC-compliant design is required to maintain the specified limit values.

- ▶ Attach the grounding connection to the protective earth with a short cable (e.g. the PE terminal for DIN EN mounting rails)
- ▶ The interface cable must be shielded. Make sure that there is a good electrical connection between the shield and the connector shell.
- ▶ Connect the shields to the cables at both ends.

### 4.2 Mechanical installation

*Configuring resistor network* ▶ If necessary, remove the resistor network before mounting. The following applies:

Resistor network	Level
plugged in (75Ω, standard from the factory)	5 V level ( $U_S = 2.5V \dots 5.25V$ )
not plugged in	24 V level ( $U_S = 20V \dots 30V$ )

The resistor network can be removed easily by levering it from above at point (A) and (B) with a small screwdriver (see Figure 4.1).

*Mounting USIC* ▶ Mount the USIC as close as possible to the master controller (signal source) simply by clicking it on to a top-hat rail.  
▶ Make sure that there is a short connection to the PE terminal.

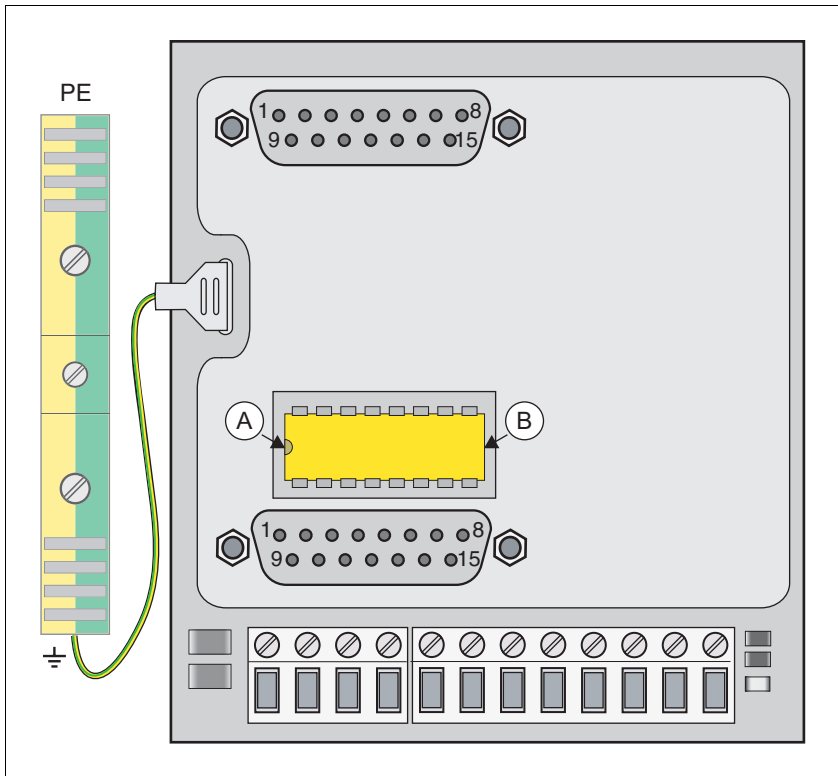

Figure 4.1 Resistor network and connection to PE

### 4.3 Electrical installation

#### 4.3.1 Overview of connections

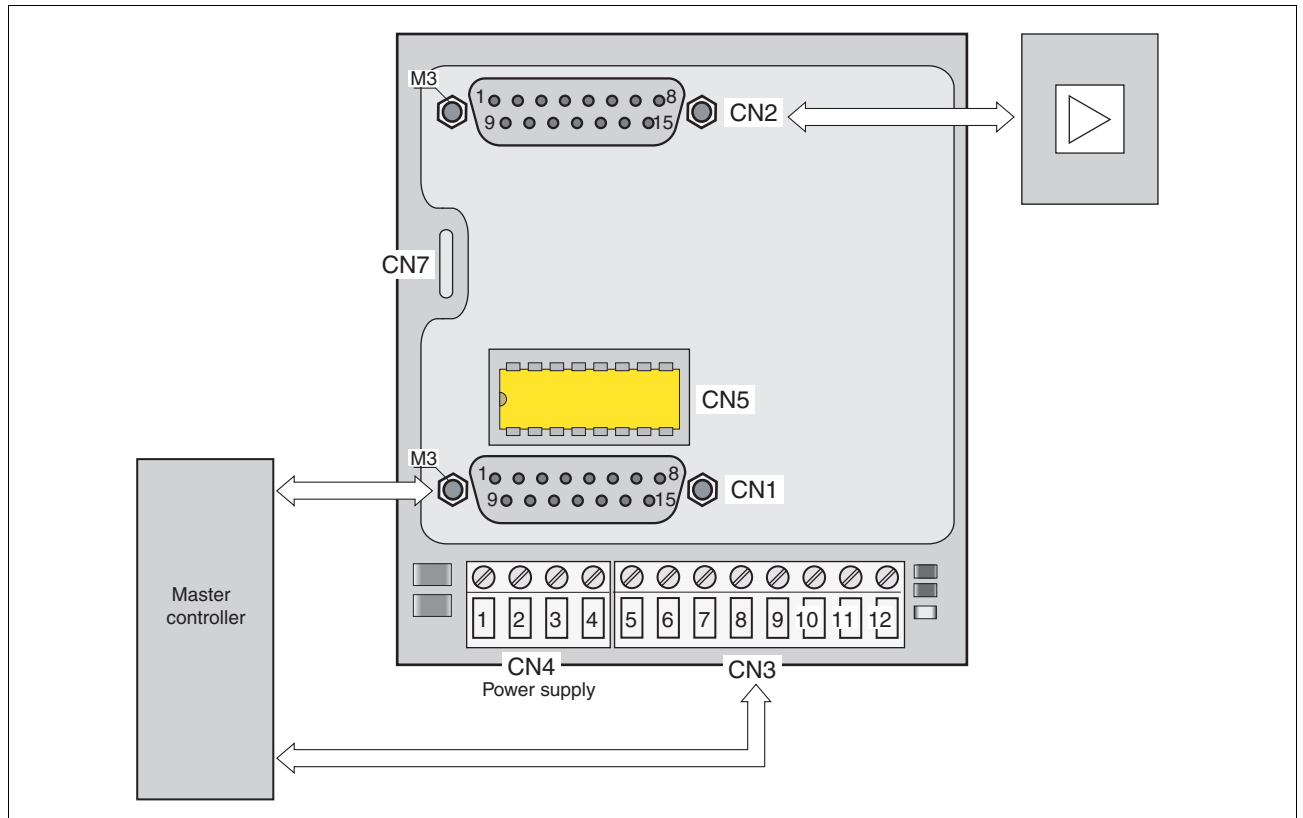

Figure 4.2 Overview of all connections

#### Assignment of CN3 and CN4

Pin	Signal <sup>1)</sup>	Meaning	I/O
1	+24VDC	external power supply (internally connected with pin 2)	I
2	+24VDC	external power supply (internally connected with pin 1)	I
3	0VDC	ground	I
4	0VDC	ground	I
5	ENABLE	Enable signal (+)	I
6	$\overline{\text{ENABLE}}$	Enable signal, inverted (-)	I
7	PWM	Current reduction (+)	I
8	$\overline{\text{PWM}}$	Current reduction, inverted (-)	I
9	STEP2_INV	Angular resolution transfer (+)	I
10	$\overline{\text{STEP2\_INV}}$	Angular resolution transfer, inverted (-)	I
11	ACTIVE2_OUT	0: Power amplifier is locked 1: Power amplifier is enabled	O
12	FAULT_OUT	0: Error message 1: Normal operating status	O

1) Depending on the connected products and their operating modes, signals may remain unused.

Assignment of CN1 and CN2

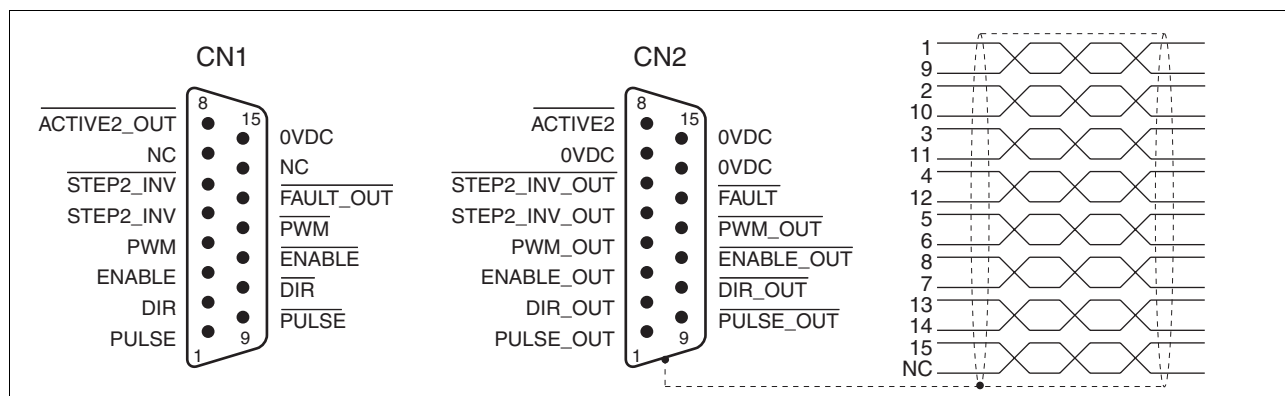

Figure 4.3 Pin assignment

Pin	Signal CN1	Signal CN2	Colour <sup>1)</sup>	Meaning	I/O (CN1)	I/O (CN2)
1	PULSE	PULSE_OUT	white	Motor step (+)	I	O
9	$\overline{\text{PULSE}}$	$\overline{\text{PULSE\_OUT}}$	brown	Motor step, inverted (-)	I	O
2	DIR	DIR_OUT	green	Direction of rotation (+)	I	O
10	$\overline{\text{DIR}}$	$\overline{\text{DIR\_OUT}}$	yellow	Direction of rotation, inverted (-)	I	O
3	ENABLE	ENABLE_OUT	grey	Enable signal (+)	I	O
11	$\overline{\text{ENABLE}}$	$\overline{\text{ENABLE\_OUT}}$	pink	Enable signal, inverted (-)	I	O
4	PWM <sup>2)</sup>	PWM_OUT <sup>2)</sup>	blue	Current reduction (+)	I	O
12	$\overline{\text{PWM}}$	$\overline{\text{PWM\_OUT}}$	red	Current reduction, inverted (-)	I	O
5	STEP2_INV <sup>2)</sup>	STEP2_INV_OUT <sup>2)</sup>	black	Angular resolution transfer (+)	I	O
6	$\overline{\text{STEP2\_INV}}$	$\overline{\text{STEP2\_INV\_OUT}}$	purple	Angular resolution transfer, inverted (-)	I	O
8	$\overline{\text{ACTIVE2\_OUT}}$	$\overline{\text{ACTIVE2}}$	red/blue	0: Power amplifier is enabled 1: Power amplifier is locked	O	I
13	$\overline{\text{FAULT\_OUT}}$ <sup>2) 3)</sup>	$\overline{\text{FAULT}}$	white/green	0: Normal operating status 1: Error message	O	I
15	0VDC	0VDC	white/yellow	ground	-	-
7	NC	0VDC	grey/pink	ground	-	-
14	NC	0VDC	brown/green	ground	-	-

1) Information on colour refers to the wires available as accessories.

2) Pins are not assigned with all power amplifiers.

3) At Twin Line the signal is called  $\overline{\text{FUNCT\_OUT}}$



*Prefabricated cables* Prefabricated cables can be found in the relevant device manuals.

A shielded cable with an open end is recommended for CN1 for the universal connection to a master controller. One end of the cable has a 15-pin female connector fitted. For the order numbers see the table below:

Order number	Length
VW3M8210R05	[m] 0.5
VW3M8210R15	[m] 1.5
VW3M8210R30	[m] 3
VW3M8210R50	[m] 5

### 4.3.2 Power supply connection

#### DANGER

##### Electric shock from incorrect power supply unit

The +24VDC supply voltage is connected with many accessible signals in the drive system.

- Use a power supply unit that meets the requirements for PELV (Protective Extra Low Voltage)
- Connect the negative output of the power supply unit to PE.

**Failure to follow these instructions will result in death or serious injury.**

- ▶ Connect an external 24V power supply to CN4. This voltage is always required, regardless of whether 5V signals or 24V signals are used.

4.3.3 Connection of signals

**⚠ CAUTION**

**Destruction of the product and loss of control**

With the CN5 resistor network plugged in the inputs at CN1 are only designed for 5V. Excessive voltage can cause destruction of the product either immediately or at a later time.

- Check the wiring.

**Failure to follow these instructions can result in injury or equipment damage.**

The USIC offers several variants for signal connection circuits. For two sample applications see page 4-7.

Make sure that the wiring, the cables and the connected interfaces meet the requirements for PELV.

All inputs can be connected as 5V signals (example 1), 24V signals (example 2) or a combination of both (example 3).  $\overline{\text{PULSE/PULSE}}$  and  $\overline{\text{DIR/DIR}}$  can only be connected via CN1.

	Example 1	Example 2	Example 3
CN3 (24V signals)			$\overline{\text{ENABLE/ENABLE}}$ $\overline{\text{PWM/PWM}}$ $\overline{\text{STEP2\_INV/STEP2\_INV}}$
CN1 with resistor network (5V signals)	$\overline{\text{ENABLE/ENABLE}}$ $\overline{\text{PWM/PWM}}$ $\overline{\text{STEP2\_INV/STEP2\_INV}}$ $\overline{\text{PULSE/PULSE}}$ $\overline{\text{DIR/DIR}}$		$\overline{\text{PULSE/PULSE}}$ $\overline{\text{DIR/DIR}}$
CN1 without resistor network (24V signals)		$\overline{\text{ENABLE/ENABLE}}$ $\overline{\text{PWM/PWM}}$ $\overline{\text{STEP2\_INV/STEP2\_INV}}$ $\overline{\text{PULSE/PULSE}}$ $\overline{\text{DIR/DIR}}$	

4.3.4 Application examples

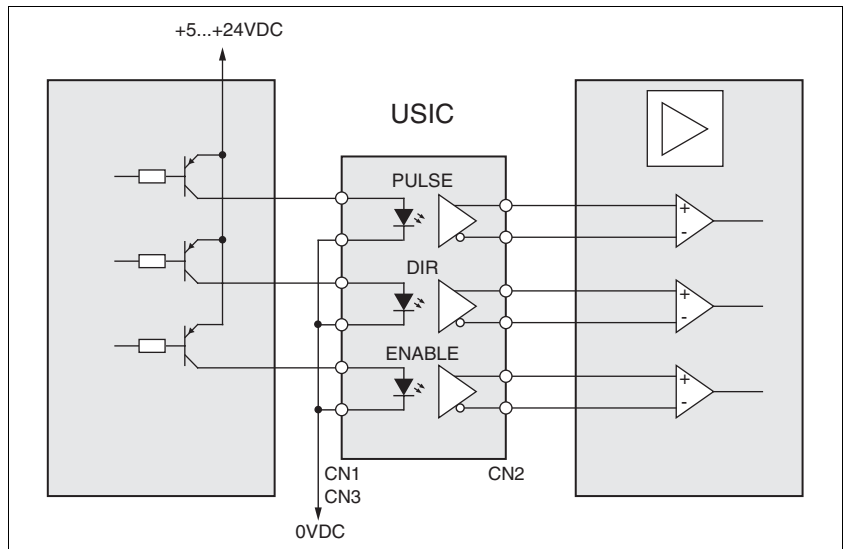

Figure 4.4 Schematic: PLC with current delivering outputs (source) over the USIC on the drive booster

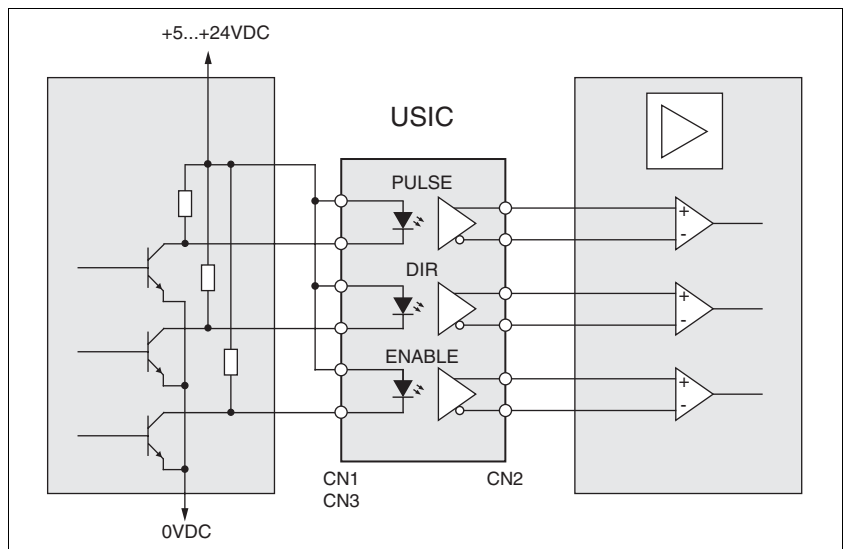

Figure 4.5 Schematic: PLC with current consuming outputs (sink) over the USIC on the drive booster

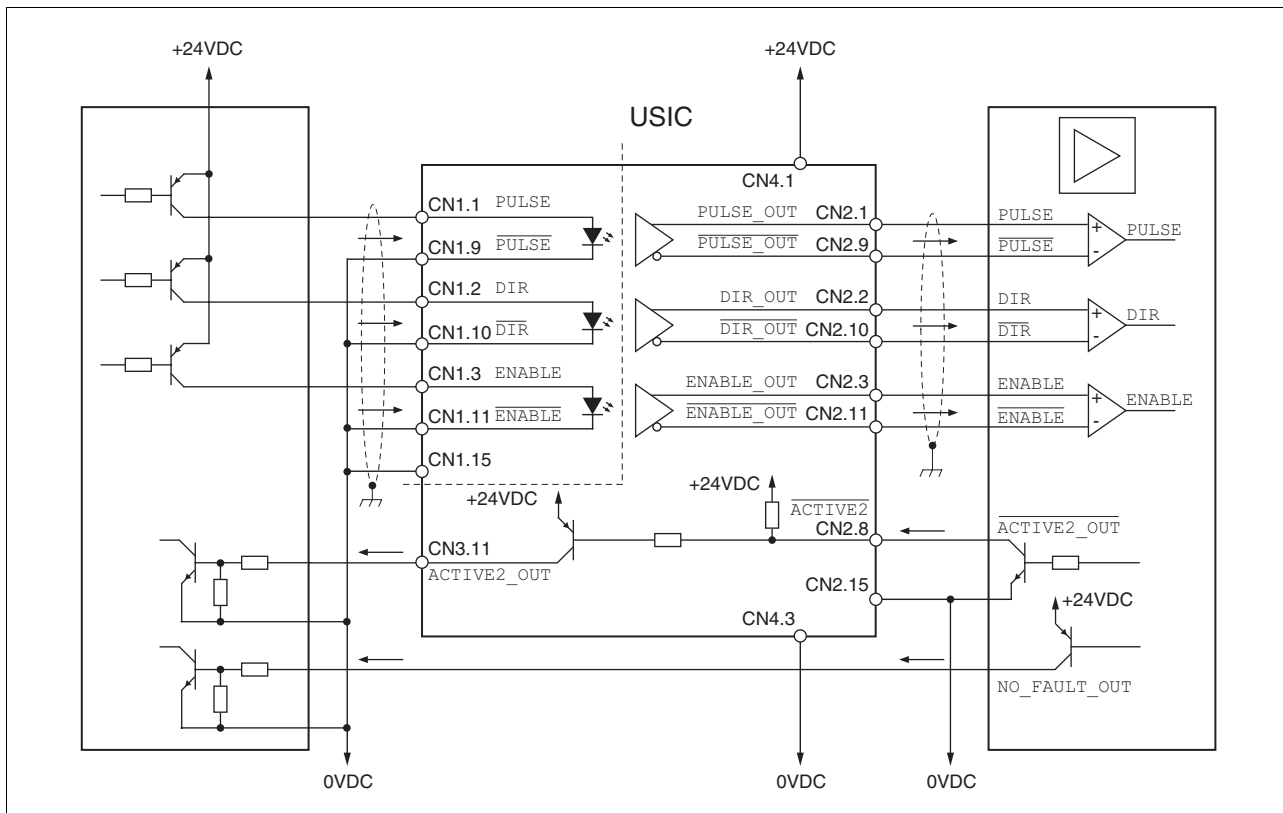

Figure 4.6 Example: Connection of a PLC over the USIC to the drive booster

### 4.3.5 Checking installation

After completion of all steps we recommend checking the installation to prevent any errors before operation of the system.

► Check in detail:

- Is the resistor network adjusted for the 5V or 24V input level?
- Is the power supply correctly connected?
- Are the signal cables connected correctly? If you are not using pre-fabricated cables: is the signal assignment correct?
- Are the shields and PE correctly connected?

## 5 Commissioning

- The installation must be conducted correctly before commissioning the USIC.
- ▶ Check the LED to make sure that the unit has power.

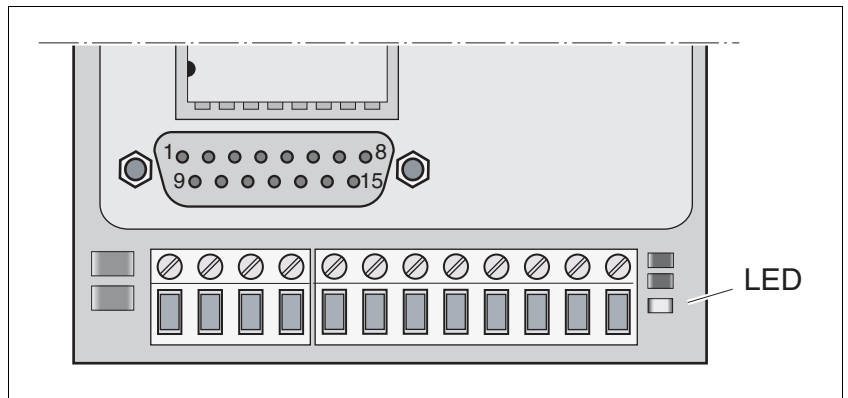

Figure 5.1 Position of the LED for display of the power supply

- ▶ Check that the motor is rotating in the correct direction.
- ▶ Conduct positioning movements with direction reversals during the test. A reversal of the active edge at the *PULSE* signal can cause displacement of the position when reversing the direction.



## 6 Service, maintenance and disposal

### 6.1 Service address

If you cannot resolve the fault yourself please contact your appointed sales partner. Have the following details available:

- Type, identification number and serial number of the product (type plate)
- Type of fault (possibly with fault number)
- Previous and concurrent conditions
- Your own ideas regarding the cause of the fault

Include this information if you return the product for inspection or repair.



*If you have any questions please contact your local dealer. Your dealer will be happy to give you the name of a customer service outlet in your area.*

<http://www.telemecanique.com>

### 6.2 Maintenance

The product is maintenance free.



*You cannot carry out repairs yourself. The repair should only be carried out by a certified customer service organisation. No warranty or liability is accepted for repairs made by the customer.*

### 6.3 Shipping, storage, disposal

*Shipping* The product must be protected against shocks during transport. Use the original packaging for this purpose.

*Storage* Store the product only under the specified, approved environmental conditions for room temperature and humidity. Protect the product against dust and dirt.

*Disposal* The product consists of various materials that can be recycled and must be disposed of separately. Dispose of the product in accordance with local regulations





## 7 Glossary

### 7.1 Terms and Abbreviations

<i>Direction of rotation</i>	Rotation of the motor shaft in a positive or negative direction of rotation. A positive direction of rotation is defined as the motor shaft rotating clockwise as the observer faces the end of the protruding shaft.
<i>EMC</i>	Electromagnetic compatibility.
<i>I/O</i>	Inputs/Outputs
<i>LED</i>	Light-Emitting Diode
<i>PELV</i>	Protective Extra Low Voltage, functional low voltage with safe isolation.
<i>PLC</i>	Programmable Logic Controller
<i>Power amplifier</i>	A device that generates current for controlling the motor in accordance with the positioning signals from the controller.
<i>Protection class</i>	The protection class is a standardised specification for electrical equipment that describes the protection against the ingress of foreign bodies and water (for example, IP20).



## 8 Index

### A

Abbreviations 7-1

### C

Commissioning 5-1

Configuring resistor network 4-2

Connections 4-3

Connector assignment 4-3

### D

Declaration of conformity 1-2

Directives 1-1

Directives and standards 1-1

Disposal 6-1

### E

Electrical installation 4-3

EMC 4-1

Environment

    temperature operation 3-1

Environmental conditions 3-1

### F

Functions 1-1

### G

Glossary 7-1

### I

Installation

    electrical 4-3

    mechanical 4-2

Intended use 2-1

Introduction 1-1

### M

Maintenance 6-1

Mechanical installation 4-2

### P

Power Removal

    application examples 4-7

### Q

Qualifications, personnel 2-1

**S**

Safety function  
    application examples 4-7  
Service 6-1  
Service address 6-1  
Shipping 6-1  
Signal inputs  
    electrical characteristics 3-2  
Signal outputs  
    electrical characteristics 3-2  
Standards 1-1  
Storage 6-1

**T**

Technical data 3-1  
Terminal assignment 4-3  
Terms 7-1