

SCADAPack E

5405 Digital Input Module Hardware Manual

Version: 8.14.3

Date: August 2017



Table of Contents

1	Legal Information.....	4
2	Technical Support.....	5
3	Safety Information.....	6
4	Overview.....	9
5	Installation.....	10
6	DIP Switch Settings.....	13
7	Operation and Maintenance.....	15
8	Calibration.....	16
9	Specifications.....	17
10	Approvals and Certifications.....	19

1 Legal Information

The information provided in this documentation contains general descriptions and/or technical characteristics of the performance of the products contained herein. This documentation is not intended as a substitute for and is not to be used for determining suitability or reliability of these products for specific user applications. It is the duty of any such user or integrator to perform the appropriate and complete risk analysis, evaluation and testing of the products with respect to the relevant specific application or use thereof. Neither Schneider Electric nor any of its affiliates or subsidiaries shall be responsible or liable for misuse of the information contained herein. If you have any suggestions for improvements or amendments or have found errors in this publication, please notify us.

No part of this document may be reproduced in any form or by any means, electronic or mechanical, including photocopying, without express written permission of Schneider Electric.

All pertinent state, regional, and local safety regulations must be observed when installing and using this product. For reasons of safety and to help ensure compliance with documented system data, only the manufacturer should perform repairs to components.

Trademarks

Schneider Electric, ClearSCADA, SCADAPack, Trio, Modbus, and StruxureWare are trademarks and the property of Schneider Electric SE, its subsidiaries and affiliated companies. All other trademarks are the property of their respective owners.

Address

Schneider Electric

415 Legget Drive, Suite 101, Kanata, Ontario K2K 3R1 Canada

Direct Worldwide: +1 (613) 591-1943

Fax: +1 (613) 591-1022

Toll Free within North America: 1 (888) 267-2232

www.schneider-electric.com

© 2014 - 2017 Schneider Electric Canada Inc.

All rights reserved.

2 Technical Support

Questions and requests related to any part of this documentation can be directed to one of the following support centers.

Technical Support: Americas, Europe, Middle East, Asia

Available Monday to Friday 8:00am – 6:30pm Eastern Time

Toll free within North America 1-888-226-6876

Direct Worldwide +1-613-591-1943

Email supportTRSS@schneider-electric.com

Technical Support: Australia

Inside Australia 1300 369 233

Email au.help@schneider-electric.com

3 Safety Information

Important Information

Read these instructions carefully and look at the equipment to become familiar with the device before trying to install, operate, service, or maintain it. The following special messages may appear throughout this documentation or on the equipment to warn of potential hazards or to call attention to information that clarifies or simplifies a procedure.



The addition of this symbol to a Danger or Warning safety label indicates that an electrical hazard exists, which will result in personal injury if the instructions are not followed.



This is the safety alert symbol. It is used to alert you to potential personal injury hazards. Obey all safety messages that follow this symbol to avoid possible injury or death.

DANGER

DANGER indicates a hazardous situation which, if not avoided, **will result in** death or serious injury.

WARNING

WARNING indicates a hazardous situation which, if not avoided, **can result in** death or serious injury.

CAUTION

CAUTION indicates a potentially hazardous situation which, if not avoided, **can result in** minor or moderate injury.

NOTICE

NOTICE is used to address practices not related to physical injury.

Please Note

Electrical equipment should be installed, operated, serviced, and maintained only by qualified personnel. No responsibility is assumed by Schneider Electric for any consequences arising out of the use of this material.

A qualified person is one who has skills and knowledge related to the construction, installation, and operation of electrical equipment and has received safety training to recognize and avoid the hazards involved.

Before You Begin

Do not use this product on machinery lacking effective point-of-operation guarding. Lack of effective point-of-operation guarding on a machine can result in serious injury to the operator of that machine.

 WARNING
EQUIPMENT OPERATION HAZARD
<ul style="list-style-type: none">• Verify that all installation and set up procedures have been completed.• Before operational tests are performed, remove all blocks or other temporary holding means used for shipment from all component devices.• Remove tools, meters, and debris from equipment.
Failure to follow these instructions can result in death or serious injury.

Follow all start-up tests recommended in the equipment documentation. Store all equipment documentation for future reference.

Test all software in both simulated and real environments.

Verify that the completed system is free from all short circuits and grounds, except those grounds installed according to local regulations (according to the National Electrical Code in the U.S.A, for instance). If high-potential voltage testing is necessary, follow recommendations in equipment documentation to help prevent accidental equipment damage.

Operation and Adjustments

The following precautions are from the NEMA Standards Publication ICS 7.1-1995 (English version prevails):

- Regardless of the care exercised in the design and manufacture of equipment or in the selection and ratings of components, there are hazards that can be encountered if such equipment is improperly operated.
- It is sometimes possible to misadjust the equipment and thus produce unsatisfactory or unsafe operation. Always use the manufacturer's instructions as a guide for functional adjustments. Personnel who have access to these adjustments should be familiar with the equipment manufacturer's instructions and the machinery used with the electrical equipment.
- Only those operational adjustments actually required by the operator should be accessible to the operator. Access to other controls should be restricted to help prevent unauthorized changes in operating characteristics.

Acceptable Use

SCADAPack E remote Programmable Automation Controllers (rPACs), Remote Terminal Units (RTUs) and input/output (I/O) modules are intended for use in monitoring and controlling non-critical equipment only. They are not intended for safety-critical applications.

WARNING

UNACCEPTABLE USE

Do not use SCADAPack E rPACs, RTUs, or I/O modules as an integral part of a safety system. These devices are not safety products.

Failure to follow this instruction can result in death or serious injury.

CAUTION

EQUIPMENT OPERATION HAZARD

When devices are used for applications with technical safety requirements, the relevant instructions must be followed.

Use only Schneider Electric software or approved software with Schneider Electric hardware products.

Failure to follow these instructions can result in minor or moderate injury.

4 Overview

The Model 5405 Digital Input module adds 32 discrete inputs to a 5000 I/O system. Up to 16 Model 5405 modules may be installed on an I/O bus to provide a total of 512 digital inputs.

The digital inputs are optically isolated from the logic power. To simplify field wiring, the inputs are grouped with eight inputs sharing a single common return. These groups of eight inputs are isolated from each other. Light emitting diodes on the Model 5405 show the status of each of the inputs.

The Model 5405 Digital Input module is available in two standard voltage ranges, for both AC and DC applications. A current limiting resistor on each input determines the voltage range. These resistors can be easily changed to accommodate non-standard signal ranges.



Figure 1: 5405 Digital Input Module

5 Installation

The installation of the 5405 module requires mounting the module on the 7.5mm by 35mm DIN rail and connecting the module to the system I/O Bus. Refer to the **System Configuration Guide**, at the beginning of this manual, for complete information on system layout, I/O Bus cable routing and module installation.

Field Wiring

Controller, modem and I/O modules use screw termination style connectors for termination of field wiring. They accommodate solid or stranded wires from 22 to 12 AWG. The connectors are removable. This allows module replacement without disturbing the field wiring. Leave enough slack in the wiring for the connector to be removed.

Remove power before servicing unit.

To remove the connector:

- Pull the connector upward from the board. Apply even pressure to both ends of the connector.

To install the connector:

- Line up the pins on the module with the holes in the connector.

Push the connector onto the pins. Apply even pressure to both ends on the connector.

NOTICE

UNEXPECTED EQUIPMENT OPERATION

Do not exceed the maximum voltage specified for each digital input.

Failure to follow these instructions can result in equipment damage.

⚠ WARNING

HAZARD OF ELECTRIC SHOCK

Remove power from all devices before connecting or disconnecting inputs or outputs to any terminal or installing or removing any hardware.

Failure to follow these instructions can result in death or serious injury.

The 5405 module provides 32 digital inputs. The input voltage range is set at the factory. The inputs are grouped with eight inputs sharing a single common return. The groups are isolated from each other.

The 5405 module accommodates AC or DC inputs. Signal polarity must be observed when using DC inputs. Connect the positive signal to the input. Connect the negative signal to the common return.

120VAC digital inputs do not work with some UPSs (uninterruptable power supplies). The

internal circuitry of the 5606 I/O module is looking for a minimum on time generated by a sine-wave signal. The 5606 I/O module should not be used with non-sine wave UPSs.

AC Input Wiring

Figure 2: AC Input Wiring Example is an example showing two 120Vac contacts monitored by Digital Inputs 0 and 1 on P3. The Model 5405 is available in different input voltage ranges. Check that the monitored voltages do not exceed the specified range of the input module. Similar wiring is possible on the remaining 24 inputs connected to P4 through P6. This wiring example shows a simplified representation of channels 0 and 1 in the 5405 module.

120 VAC digital inputs don't work with some UPSs. The digital input firmware is looking for a minimum input on-time generated by a sine-wave. This time is longer than the on-time generated by some UPSs. The module should not be used with a non-sine wave UPS.

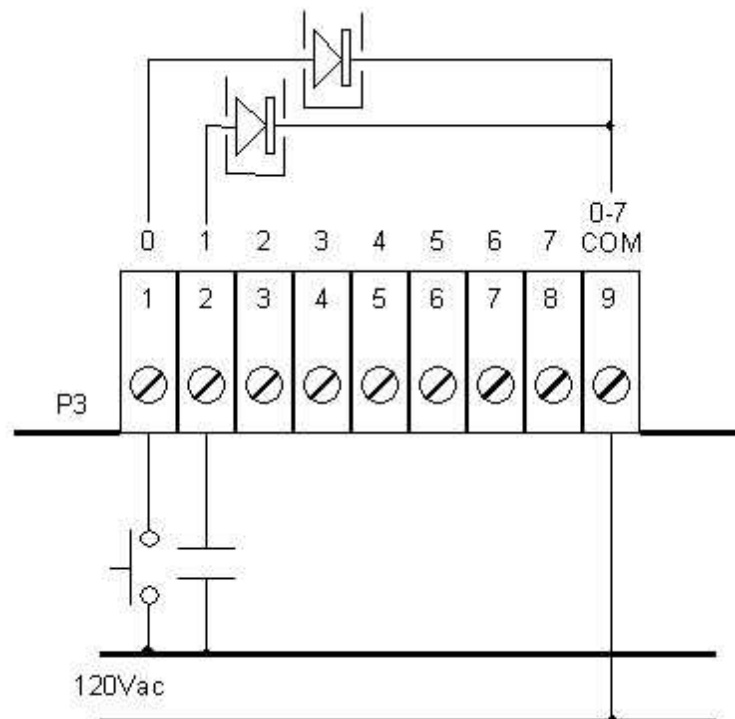

Figure 2: AC Input Wiring Example

DC Input Wiring

Figure 3: DC Input Wiring Example is an example showing two 24Vdc contacts monitored by Digital Inputs 8 and 9 on P4. Observe signal polarity when using DC signals. The Model 5405 is available in different input voltage ranges. Check that the signals monitored are in the specified range of the input module. Similar wiring is possible on the remaining 24 inputs connected to P3, P5 and P6. This wiring example shows a simplified representation of channels 8 and 9 in the 5405 module.

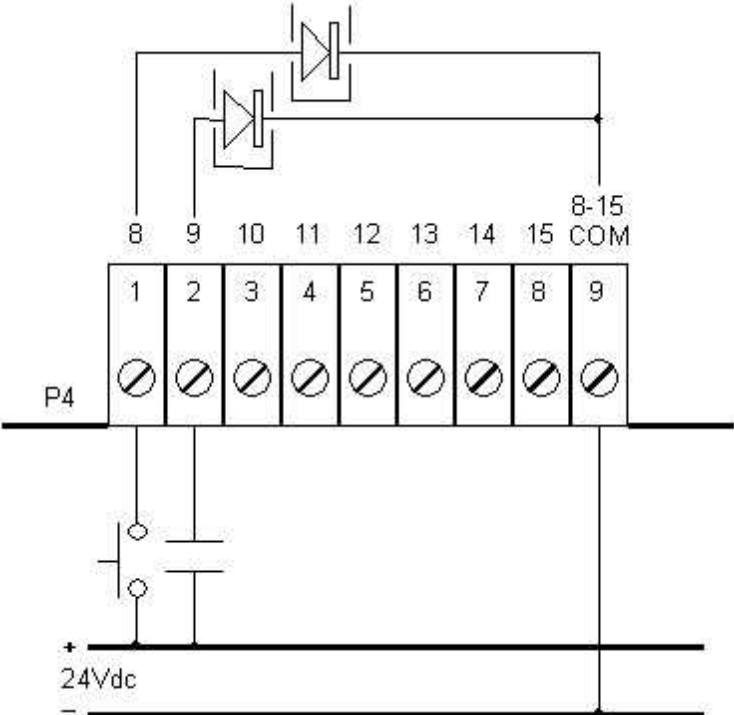

Figure 3: DC Input Wiring Example

6 DIP Switch Settings

Address Selection

5000 Series I/O module types may be combined in any manner to the maximum supported by the controller used.

Each type of I/O module, connected to the I/O bus, has a unique I/O module address. Different types of I/O modules may have the same module address.

The address range supported by the SCADAPack controller module may restrict the I/O module address range. Refer to the controller manual for the maximum address supported.

Each analog input module has a unique set of channels. The four address switches labeled 1, 2, 4 and 8 set the module address. To set the address:

- Open the four switches by sliding the actuator to the left side of the switch.
- Slide actuators to the right such that they total the desired address.

Switch settings for each of the 16 module addresses are shown in **Figure 4: 5405 Digital Input Module Address Switches**

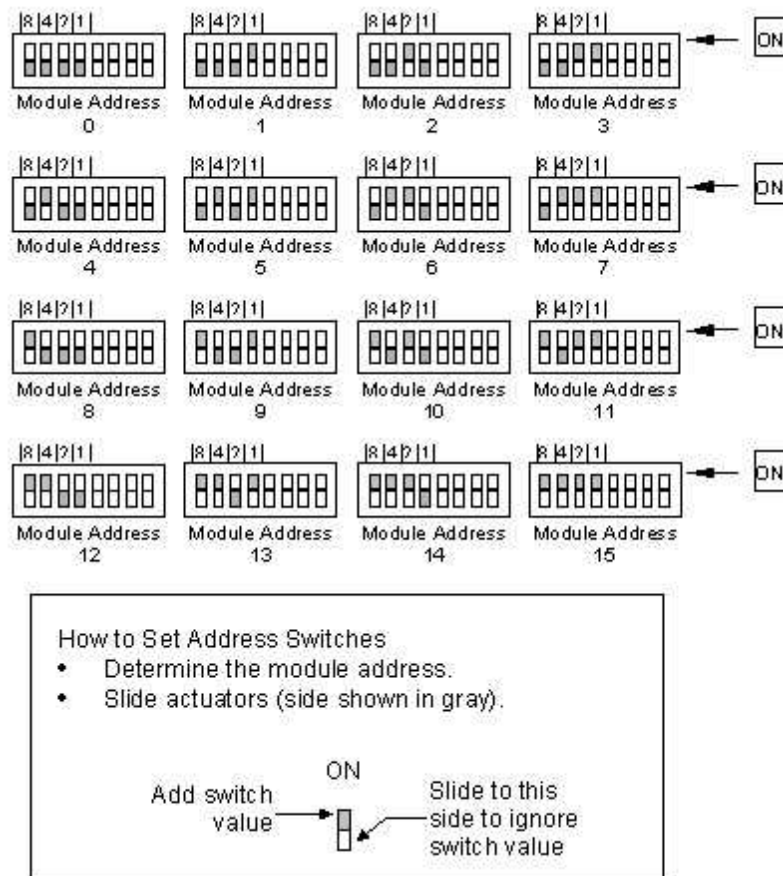

Figure 4: 5405 Digital Input Module Address Switches

AC/DC Input and Frequency Selection

The Model 5405 Digital Input module is capable of monitoring AC or DC inputs. The user should set the switches on the module according to the type of signal (AC or DC) and, if AC, according to the frequency of operation.

AC/DC Operation

Switch 6 selects AC or DC operation. Refer to **Figure 5: Switches 5&6**.

For DC operation:

- Slide the actuator up to the “ON” position. The 5405 module responds faster in this position.

For AC operation:

- Slide the actuator down to the “OFF” position. The 5405 response is filtered according to frequency selection of Switch 5.

Frequency Selection

Switch 5 selects 50 or 60Hz. operation in AC mode only. Refer to **Figure 5: Switches 5&6**

For 50Hz. operation:

- Slide the actuator up to the “ON” position.

For 60Hz. operation:

- Slide the actuator down to the “OFF” position.

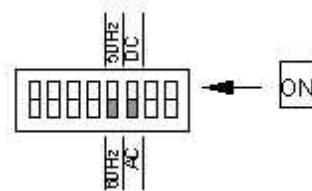

Switches 5 and 6
Actuators (gray)
shown for AC 60Hz
operation

Figure 5: Switches 5&6

7 Operation and Maintenance

The **5405 modules** require no routine maintenance or calibration. If a module is not functioning correctly, contact Technical Support for more information and instructions for returning the module for repair.

LED Indicators

The Model 5405 Digital Input Module has one red status LED per I/O point. This LED is on when the input is monitoring a voltage greater than the minimum rated input voltage.

The digital input status LED is located between the field wiring terminal connector and the module cover.

The LED is powered by the field wiring and cannot be disabled. The intensity of the LED will vary slightly as a function of the voltage present on the digital input.

Troubleshooting

Condition	Action
Input LED does not come on when input signal is applied.	Check the input signal at the termination block. If this is a DC input, check the polarity of the signal.

8 Calibration

The 5405 module is calibrated at the factory. It does not require periodic calibration. Calibration may be necessary if the module has been repaired as a result of damage. Calibration is done electronically at the factory. There are no user calibration procedures.

9 Specifications

Disclaimer: Schneider Electric reserves the right to change product specifications without notice. For more information visit <http://www.schneider-electric.com>.

General

I/O Terminations	Four 9 pole, removable terminal blocks 22 to 12 AWG 15 A contacts Screw termination: 0.68 N•m (6.0 lb-in) torque
Dimensions	144 mm (5.65 in) wide 127 mm (5.00 in) high 45 mm (1.80 in) deep
Packaging	corrosion resistant zinc plated steel with black enamel paint
Environment	5% RH to 95% RH, non-condensing -40 °C to 70 °C -40 °F to 158 °F
Addressing	Configurable with 4 DIP switches
AC/DC operation	2 DIP switches determine AC/DC and 50/60 Hz operation
Visual Indicators	32 Red LEDs Field Powered. Cannot be disabled to conserve power.

Power Requirements

5V	5V at 10mA with all inputs ON
----	-------------------------------

Digital Inputs

I/O points	32 points
Ranges	12-24 Vdc, 16-24 Vac 120 Vac/Vdc
Over-voltage Tolerance	150% sustained over-voltage without damage
Input Current	6.0 mA typical at 24 Vdc on the 24 V range 3.5 mA typical at 24 Vac on the 24 V range 2.5 mA typical at 120 Vdc on the 120 V range 1.5 mA typical at 120 Vac on the 12.0V range
DC Input Logic Levels	OFF to ON transition threshold is typically 7.5 Vdc on the 24 Vdc range OFF to ON transition threshold is typically 55 Vdc on the 120 Vdc range
AC Input Levels	OFF to ON transition threshold is typically 6 Vac on the 24 Vac range OFF to ON transition threshold is typically 45 Vac on the 120 Vac range
Response time	3.5 ms typical OFF to ON with DIP Switch set to DC 4.5 ms typical ON to OFF with DIP Switch set to DC 15 ms typical OFF to ON with DIP Switch set to 60 Hz AC 17 ms typical ON to OFF with DIP Switch set to 60 Hz AC 16 ms typical OFF to ON with DIP Switch set to 50 Hz AC 20 ms typical ON to OFF with DIP Switch set to 50 Hz AC
Transient Protection	2.5 kV surge withstand capability as per ANSI/IEEE C37.90.1-1989
Isolation	Isolated in four groups of 8. Inputs 0-15 are on the bottom edge. Inputs 16-31 are on the top edge. Isolation 500 Vac/Vdc from chassis and logic ground.

10 Approvals and Certifications

Hazardous Locations - North America	<p>Suitable for use in Class I, Division 2, Groups A, B, C and D Hazardous Locations. Temperature Code T4</p> <p>UL Listed and CSA certified to the following standards:</p> <ul style="list-style-type: none"> • CSA Std. C22.2 No. 213-M1987 - Hazardous Locations. • UL Std. No. 1604 - Hazardous (Classified) Locations.
Hazardous Locations - Europe	<p>5405-24 (24V DI version) only</p> <p>ATEX II 3G, Ex nA IIC T4</p> <p>per EN 60079-15, protection type n (Zone 2)</p>
Hazardous Locations	<p>IECEX, Ex nA IIC T4</p> <p>per IEC 60079-15, protection type n (Zone 2)</p>
ATEX and IECEX Applications only	<p>This equipment is to be installed in an enclosure certified for use, providing a degree of protection of IP54 or better. The free internal volume of the enclosure must be dimensioned in order to keep the temperature rating. A T4 rating is acceptable.</p> <p>For products using Solid State Relays (5415, 5606 and 5607 modules and SCADAPack using 5606 and 5607 modules) A T4 rating is acceptable for maximum loads of 2A. When 3A loads are connected to the Solid State Relays, the maximum ambient rating is lowered to 50 °C in order to maintain the T4 rating.</p>
Safety	<p>CSA (cCSAus) certified to the requirements of: CSA C22.2 No. 142-M1987 and UL916. (Process Control Equipment, Industrial Control Equipment) in Canada and USA.</p> <p>UL (cULus) listed: UL508 (Industrial Control Equipment)</p>
Digital Emissions	<p>FCC47 Part 15, Subpart B, Class A Verification</p> <p>EN61000-6-4: 2007 Electromagnetic Compatibility Generic Emission Standard Part2: Industrial Environment</p> <p>C-Tick compliance. Registration number N15744.</p>
Immunity	<p>EN61000-6-2: 2005 Electromagnetic Compatibility Generic Standards Immunity for Industrial Environments</p>
Declaration	<p>This product conforms to the above Emissions and Immunity Standards and therefore conforms with the requirements of Council Directive 2014/30/EU (as amended) relating to electromagnetic compatibility.</p> <p>Models with digital inputs configured below 30 Vdc/60 Vac are eligible to bear the CE mark.</p> <p>The Low Voltage Directive is not applicable to this product in applications below 30 Vdc/60 Vac.</p>

Schneider Electric

415 Legget Drive, Suite 101, Kanata, Ontario K2K 3R1 Canada

Direct Worldwide: +1 (613) 591-1943

Fax: +1 (613) 591-1022

Toll Free within North America: 1 (888) 267-2232

www.schneider-electric.com

Copyright © 2014 - 2017 Schneider Electric Canada Inc. All Rights Reserved.