



User Manual

APC Smart-UPS™ Charge Mobile Power Supply for Surface Hub 2 (APC Charge)

CSH2-JP

100-240 Vac

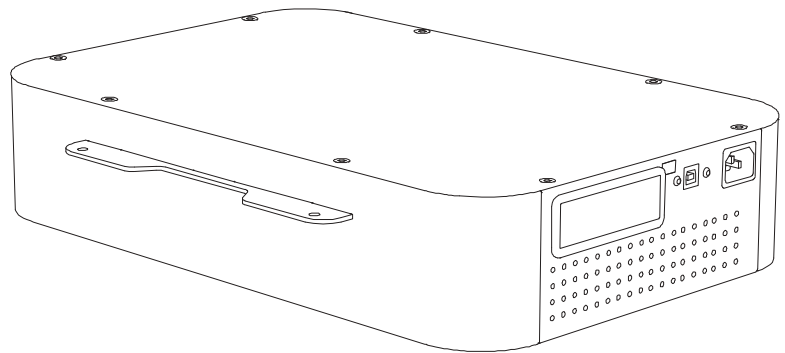

Important Safety Messages

SAVE THESE INSTRUCTIONS - This manual contains important instructions that should be followed during installation and maintenance of the APC Smart-UPS™ Charge Mobile Power Supply for Surface Hub 2 (APC Charge).

Read these instructions carefully and look at the equipment to become familiar with the device before trying to install, operate, service or maintain it. The following special messages may appear throughout this bulletin or on the equipment to warn of potential hazards or to call attention to information that clarifies or simplifies a procedure.



The addition of this symbol either to a “Danger” or “Warning” safety label indicates that an electrical hazard exists which will result in personal injury if the instructions are not followed.



This is the safety alert symbol. It is used to alert you to potential personal injury hazards. Obey all safety messages that follow this symbol to avoid possible injury or death.

DANGER

DANGER indicates a hazardous situation which, if not avoided, **will result in** death or serious injury.

WARNING

WARNING indicates a hazardous situation which, if not avoided, **could result in** death or serious injury.

CAUTION

CAUTION indicates a hazardous situation which, if not avoided, **could result in** minor or moderate injury.

NOTICE

NOTICE is used to address practices not related to physical injury.

Product Handling Guidelines



<18 kg
<40 lb



18-32 kg
40-70 lb



32-55 kg
70-120 lb



>55 kg
>120 lb



Safety and General Information

Inspect the package contents upon receipt.

Notify the carrier and dealer if there is any damage.

- Adhere to all national and local electrical codes.
- All wiring must be performed by a qualified electrician.
- Do not work alone under hazardous conditions.
- **Changes and modifications to this APC Charge not expressly approved by Schneider Electric could void the warranty.**
- **Failure to charge the APC Charge once in every 20 days could void the warranty.**
- Do not remove the covers. There are no serviceable internal parts.
- Do not operate the APC Charge in direct sunlight, in contact with fluids, or where there is excessive dust or humidity.
- The APC Charge is capable of operating in environments up to 40 °C.
- Be sure the air vents on the APC Charge are not blocked. Allow adequate space for proper ventilation.
- The equipment is heavy. Always practice safe lifting techniques adequate for the weight of the equipment.

Deenergizing safety

- Before installing or servicing the equipment check that the input power cord is disconnected from the APC Charge and the DC Output is turned OFF.

Electrical safety

- Use tools with insulated handles.
- Do not handle any metallic connector before power has been disconnected.
- The protective earth conductor for the APC Charge carries the leakage current from the load devices (Surface Hub 2). An insulated ground conductor is to be installed as part of the branch circuit that supplies power to the unit. The conductor must have the same size and insulation material as the grounded and ungrounded branch circuit supply conductors. The conductor will typically be green, with or without a yellow stripe.
- If the APC Charge input power is supplied by a separately derived system, the ground conductor must be properly bonded at the supply transformer or motor generator set.

Battery safety

- The APC Charge uses internal Li-Ion batteries.
- APC Charge typically lasts for three years. Environmental factors impact battery life. Elevated ambient temperatures, poor quality utility power, and frequent short duration discharges will shorten APC Charge life.
- CAUTION: Before installing or replacing APC Charge, remove jewelry such as wristwatches and rings. High short circuit current through conductive materials could cause severe burns.
- CAUTION: Do not dispose of APC Charge in a fire. The APC Charge may explode.
- CAUTION: Do not open or mutilate APC Charge. Released material is harmful to the skin and eyes and may be toxic.

General information

- The model and serial numbers are on a small label, located on the top cover.
- Recycle the package materials or save them for reuse.

VCCI-A Radio Frequency Warning

この装置は、クラスA機器です。この装置を住宅環境で使用すると電波妨害を引き起こすことがあります。この場合には使用者が適切な対策を講ずるよう要求されることがあります。

VCCI-A

suo1602a

Product Overview

The APC™ by Schneider Electric APC Charge Smart-UPS™ Mobile Power Supply for Surface Hub 2 (APC Charge) provides power conversion for connected equipment.

APC Charge is only applicable for Surface Hub 2 system. This APC Charge should not be used for any other applications.

The APC Charge helps to provide regulated, DC power to Surface Hub 2 system.

When AC Mains is available, APC Charge will not provide any surge protection to the Surface Hub 2.

This user manual is available on the APC by Schneider Electric Web site, www.apc.com.

Package Contents

Inspect the contents upon receipt. Notify the carrier and dealer if the APC Charge is damaged.

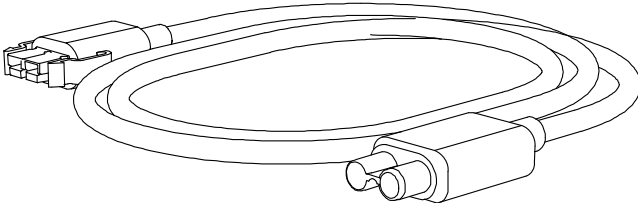
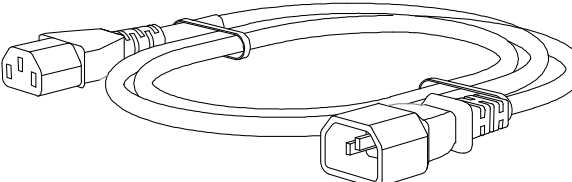
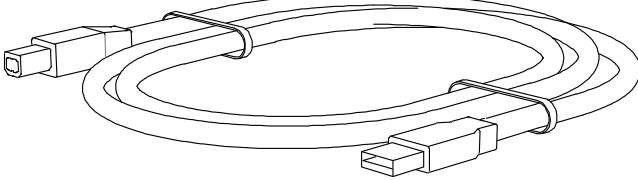
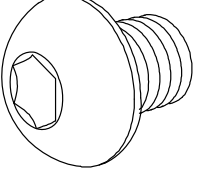
DC cable 	AC pass through cable 
USB cable 	Hex screws x4  Note: Use 4 mm Allen key to assemble the APC Charge. The key is available in the Roam Mobile Stand package.

Note: Use the AC power cord supplied with Surface Hub 2 to connect APC Charge to AC power.

Specifications

For additional specifications refer to the APC by Schneider Electric Web site, www.apc.com.

Environmental

Temperature	Operating	Typical +23 °C, 0 to +40 °C (32 to 104 °F)
	Operating Storage	0 to 40 °C (32 to 104 °F)
Maximum Elevation	Operating	3,000 m (10,000 ft)
Humidity		0 to 85% RH, non-condensing
International Protection Code		IP 20

Physical

Unit weight without packaging	11 kg (24.3 lb)
Unit weight with packaging	13.5 kg (30 lb)
Unit dimensions without packaging Width x Depth x Height	430 mm x 280 mm x 90 mm (16.9 in x 11 in x 3.5 in)
Unit dimensions with packaging Width x Depth x Height	650 mm x 515 mm x 270 mm (25.6 in x 20.3 in x 10.6 in)

Electrical

Input	
Input Voltage Range (Name Plate)	100-240 VAC
Nominal Input Voltage	100 VAC / 230 VAC
Input Current	8 A max.
Input Frequency	50 to 60 Hz
Input Configuration	Single phase, 3 wire (Line, Neutral and Ground)
External input circuit breaker (typical)	15 A / 2 pole
Wire size (typical)	14 AWG
Output AC	
Output Voltage	100-240 VAC (follows input voltage)
Output Current	4 A max.
Output Power Rating	400 W (maximum)
Output Frequency	50 to 60 Hz (follows input frequency)
Output DC	
Nominal Output Voltage	24 V DC
Output Power Rating	388 W (maximum), 200 W (typical)
Output Voltage Regulation (at the end of 1 m cable)	± 5%

Batteries

Battery type	Li-Ion Battery
Charge voltage for full capacity	58.45 V DC
Battery Charger	5.5 A

Installation

NOTICE

RISK OF FALLING EQUIPMENT

- Follow the installation instructions.
- Secure the APC Charge in the tray using all of the screws supplied for this purpose.

Failure to follow these instructions could result in equipment damage.

1

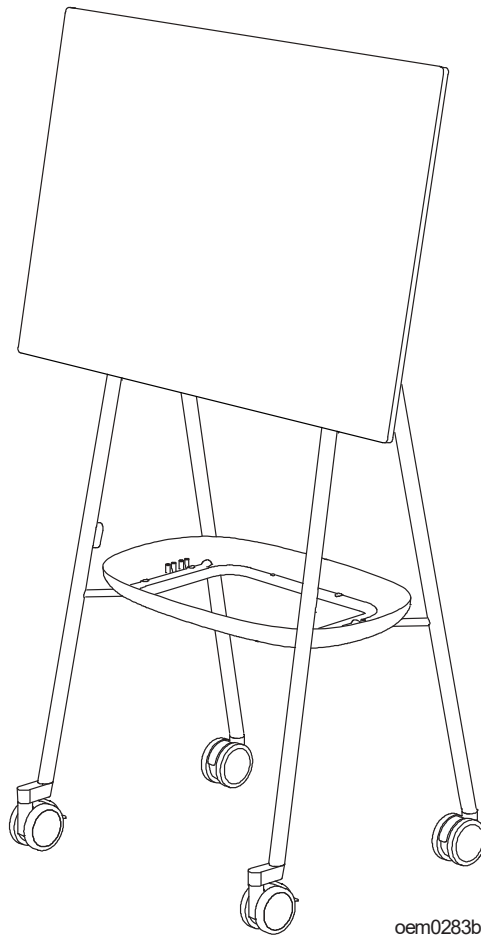

2

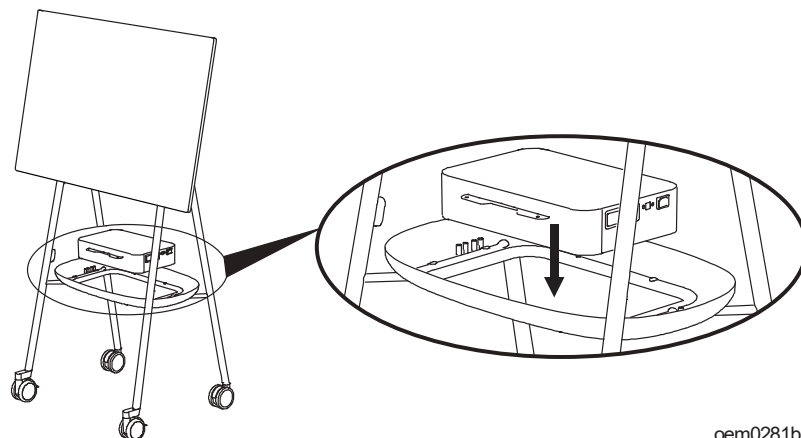

3 Secure the APC Charge to the Roam Mobile Stand using 4 hex screws

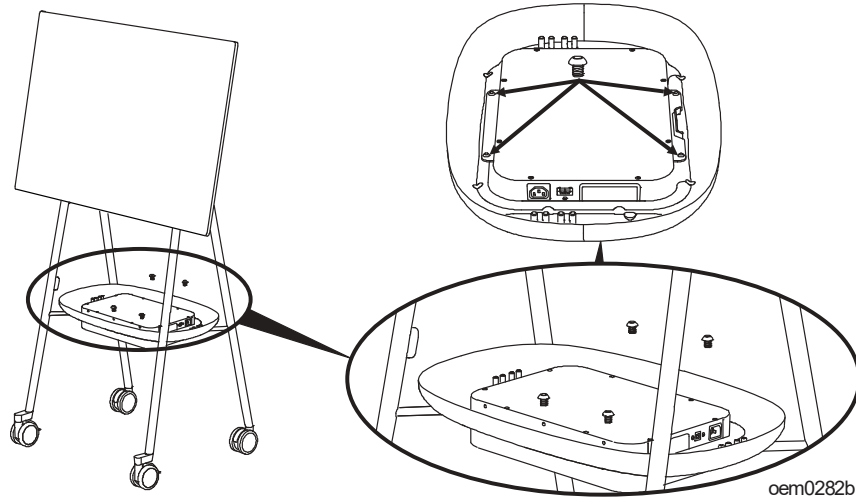

Input/Output connections

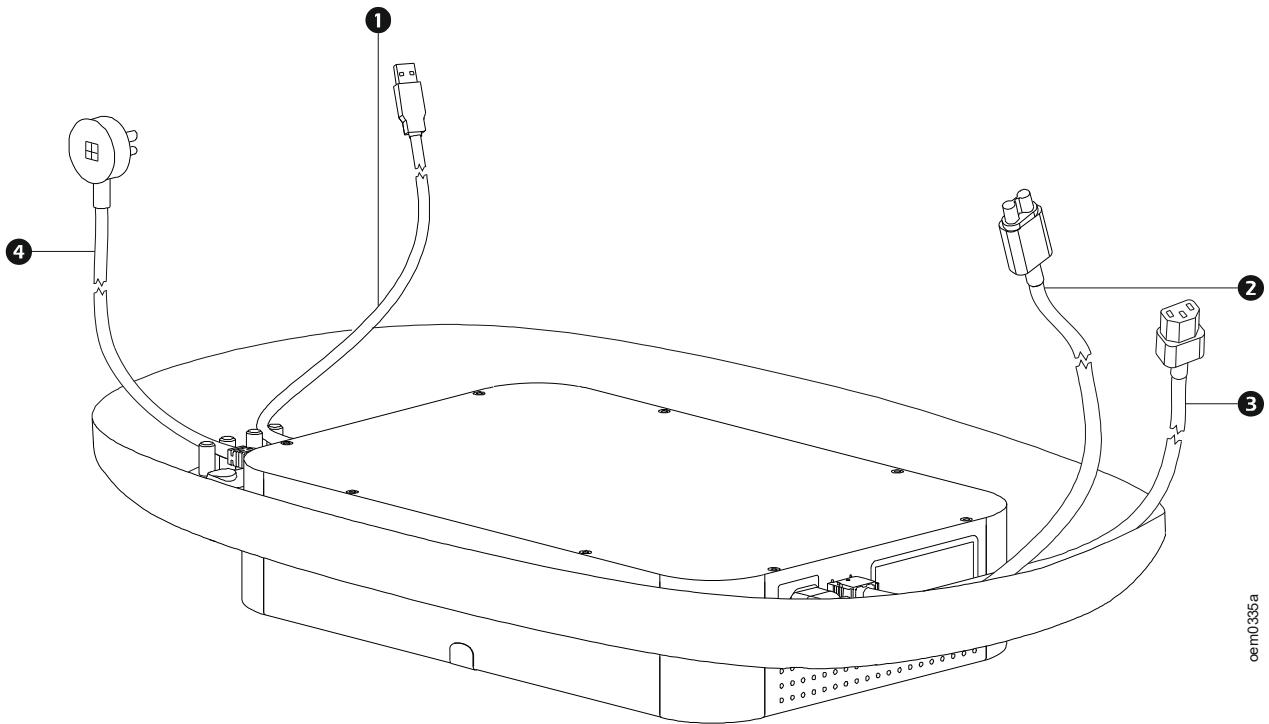

1	USB cable for onscreen battery display
2	DC cable for on battery operation
3	AC Pass Through cable for normal operation
4	AC Power Cord (supplied with Surface Hub 2)

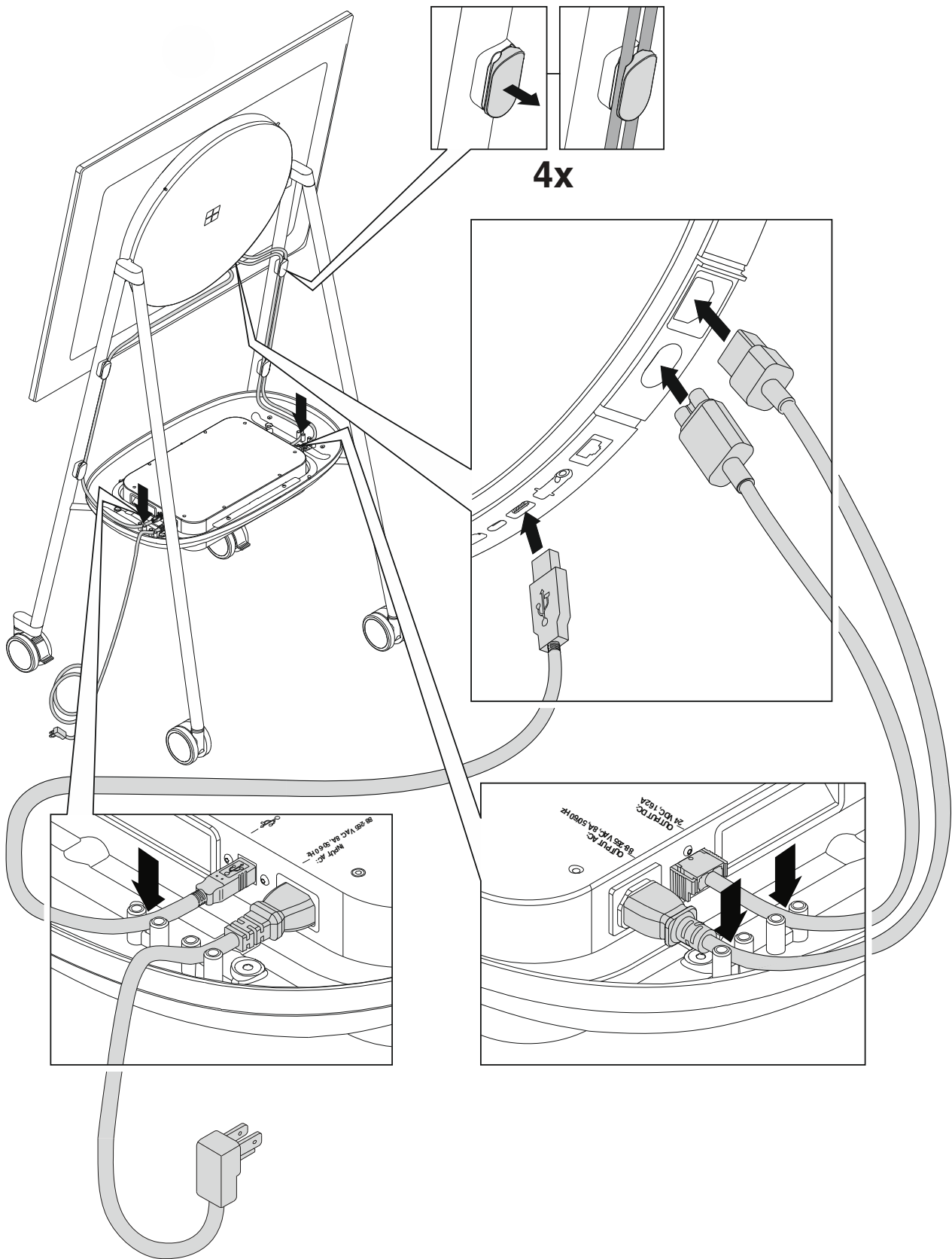

Panel Features

Note: Refer to the table “Key To Identify Front Panel Features” on page 9, that provides a key to the call-out numbers for the panel graphics depicted in this manual.

Status LEDs: 1, 2, 3, 4 and 5

(Starting from left when facing LEDs on the unit)

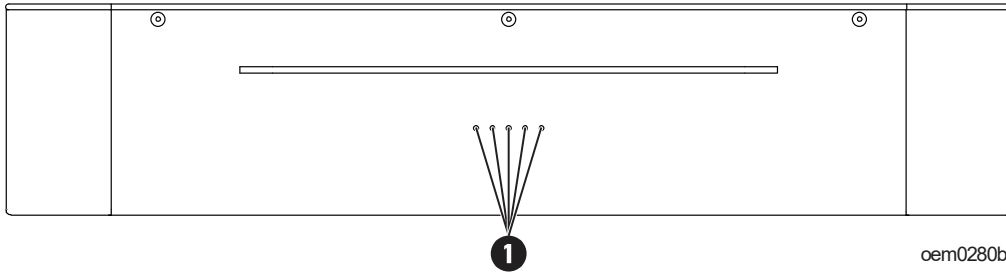

ON/OFF button

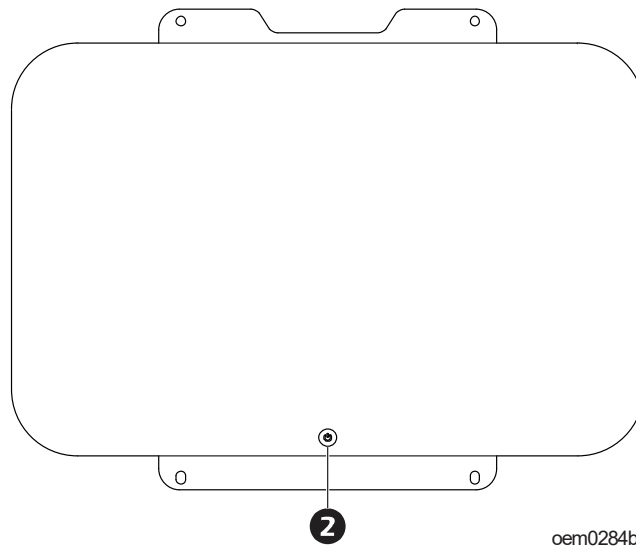

Side panel features 1

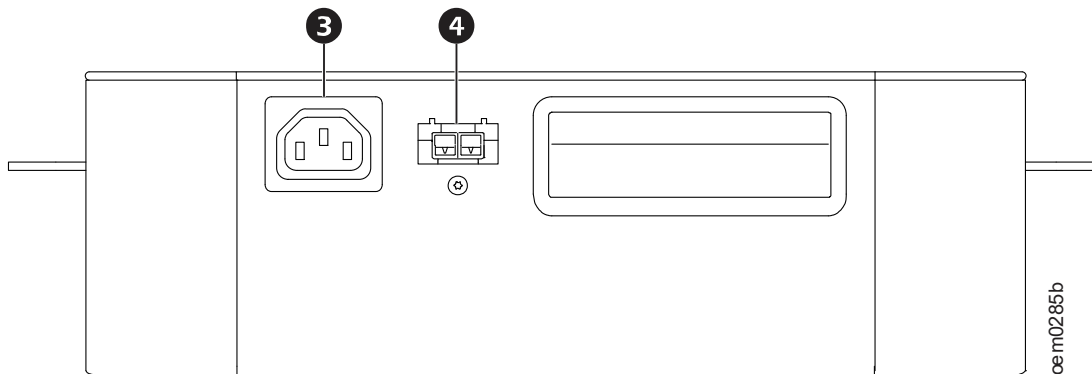

Side panel feature 2

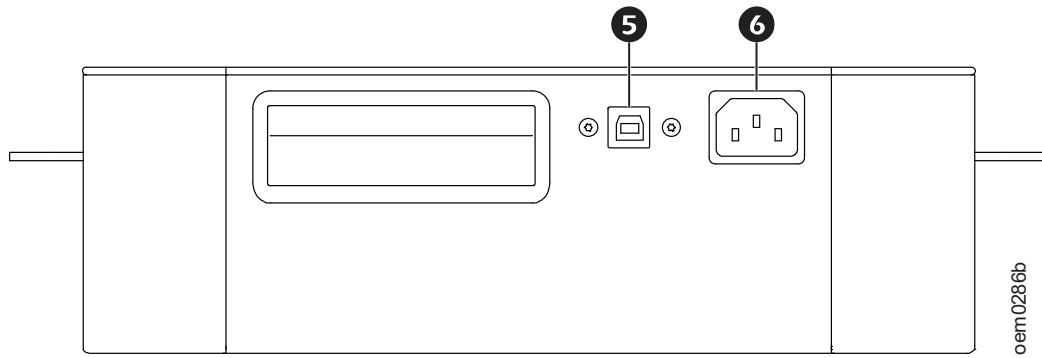

Key To Identify Front Panel Features

①	Status LEDs	The 5 status LEDs indicate the state of charge in the following manner: <ul style="list-style-type: none">• 0-20%• 21%-40%• 41%-60%• 61%-80%• 81%-100% The LED1 turns red to indicate low battery of less than 12.5% state of charge.
②	ON/OFF button	Refer “Power On/Off function” on page 10 for details.
③	AC Output Connector	IEC 60320 C13
④	DC Output Connector	This connector provides regulated 24 VDC output.
⑤	USB port Type B	Use USB type B port for Battery parameters through Human Interface Device (HID).
⑥	AC Input Connector	Use the AC power cord supplied with Surface Hub 2 to connect APC Charge to AC power.

Operation

NOTE:

1. Charge the APC Charge for 2.5 hours before turning it ON for the first time. Battery State of Charge information will be updated on the Surface Hub 2 only after the DC Output is turned ON.
2. After the charging in *step 1* is completed, turn ON the DC Output and be sure that all the 5 White LEDs are illuminating, indicating that the battery output is ON.
3. Switch OFF the AC Input power to the APC Charge and be sure that all the 5 White LEDs are still illuminating.

The APC Charge should be charged once every 20 days when not in use.

Power On/Off function

CAUTION

RISK OF ELECTRIC SHOCK

The output terminals of the APC Charge are energized as long as the input circuit breaker is on and the input voltage is applied to the input terminals.

Failure to follow these instructions could result in minor or moderate injury.

Power on

- **AC auto-wakeup:** When AC input is available in acceptable range, the APC Charge wakes up automatically and starts charging the battery. If the APC Charge had previously shut down due to low battery condition, then the output will not be enabled for 5 minutes.
- **Wake up on battery:** Press the push ON/OFF button for around 2 seconds to wake up the APC Charge in standby operation. If output is not turned on in 120 seconds, the APC Charge goes to brain dead condition automatically. In this condition all the LEDs are off.
- **Cold start on battery:** Press the ON/OFF button for more than 3 seconds and less than 6 seconds to enable the DC output voltage (24 V). LEDs illuminate white indicating the battery state of charge.
- **Online operation:** Press the ON/OFF button for more than 3 seconds and less than 6 seconds to enable 24 V DC output voltage. LEDs illuminate white indicating the battery state of charge.
- **Standby operation:** Press the ON/OFF button for more than 6 seconds and less than 20 seconds, to disable DC output voltage (24 V). In this condition all the LEDs are off and State of Charge (SOC) is communicated as 0%.
- **Alert state:** Press the ON/OFF button for more than 3 seconds and less than 6 seconds to reset the alert. See “Alert Modes” on page 11 for details. The APC Charge may again enter into alert mode if the detected fault persists. This is applicable for both modes of operation.

Power off

Press the ON/OFF button for more than 6 seconds and less than 20 seconds to turn off the APC Charge.

LED Indicators

LED1	LED2	LED3	LED4	LED5	State of charge	APC Charge Status	
Off					NA	Off	
Red LED Blinks	Off				<13%	Charger On and Output On	
White LED On	Off				13 – 20%		
White LED On		Off					21 – 40%
White LED On			Off				41 – 60%
White LED On				Off			61 – 80%
White LED On							81 – 100%
White LED On							81% – 100%
White LED On				Off		Discharging	
White LED On			Off				61% – 80%
White LED On		Off					41% – 60%
White LED On		Off					21% – 40%
White LED On	Off						13% – 20%
Red LED Blinks	Off				<13%	Charging/ Discharging	
Off						0 – 20%	
Off						21 – 40%	
Off						41 – 60%	
Off						61 – 80%	
Off						81 – 100%	

During APC Charge startup (initial power up) LED self test is performed during which all white LEDs will blink 5 times for 2 seconds and then all red LEDs will blink for 2 seconds. **LED2** will blink in red color for a maximum of 5 seconds until communication is established.

Alert Modes

LED1	LED2	LED3	LED4	LED5	Alert	Status
Off			Red LED On	Off	OTP	Over temperature alert
Off			Red LED On		DCDC	DCDC hardware alert
Off	Red LED On	Off			Charger	Charger alert
Off	Red LED On	Off	Red LED On		PFC	PFC alert
Off	Red LED On		Off		Switch	On/Off switch alert
Off	Red LED On				DC overload	DC 24 V Output overload (>115%)
Off	Red LED On	Off			Comm	BMS communication alert
Off	Red LED On	Off	Red LED On		Hardware relays	BMS hardware alert

Run Time Calibration

Perform Run Time Calibration once after every 50 Charge-Discharge cycles or once in every 2 months, whichever is earlier.

Steps for performing run time calibration:

1. Disconnect the APC Charge from AC mains and discharge the battery until “Low Batt Shutdown”.
2. Keep the APC Charge in idle state (without charging or discharging) for 2.5 hours.
3. Connect APC Charge to the AC mains until the battery is fully charged.
4. Start using the APC Charge once the battery is fully charged.

Recycling End of Life Products and Batteries



To recycle end of life products and batteries, check APC by Schneider Electric Website support for details and send end of life products and batteries to our designated collection point.

Troubleshooting

Use the table below to solve minor installation and operation problems.

Refer to the APC by Schneider Electric Web site, www.apc.com for assistance with complex problems.

The APC Charge features firmware that can be upgraded.

Go to the APC by Schneider Electric Web site, www.apc.com/Support, or contact your local Customer Care Center for more information.

Problem	Possible Cause	Solution
There is no 24 V DC output from APC Charge	APC Charge output not turned <i>on</i> .	Press ON/OFF button for 3 seconds.
Surface Hub does not turn on when AC Mains is available	AC Bypass cable not connected properly.	Be sure that the AC Bypass power cable is securely connected at both the APC Charge and Surface Hub 2.
Battery is not charging when AC Mains is available	AC power cord is not connected properly to the wall outlet or APC Charge.	Be sure that the AC power cord is securely connected to both the wall outlet and to the APC Charge.
Any of the Red LEDs are on	Refer “Alert Modes” on page 11 for details.	Press and hold the ON/OFF button for 3 seconds to reset the alert.
USB connection not detected	USB cable not connected properly.	Be sure that the USB cable is securely connected both at the APC Charge and Surface Hub 2.
Actual runtime of surface hub is lower than expected runtime.	Make sure the battery is charged for sufficient time.	Charge the battery for more time.
SOC indicated on the surface hub does not increase even though the APC charge is connected to AC Mains	APC Charge is out of calibration.	Perform run time calibration; refer “Run Time Calibration” on page 12 for details.
Surface Hub turns off when AC Mains disconnected.	DC power cable not connected properly.	Be sure that the DC power cable is securely connected at both the APC Charge and Surface Hub 2.
Surface Hub turns off even when AC Mains present	Input voltage short disturbances.	Restart the Surface Hub. Note: Both AC and DC outputs are available continuously from the APC Charge through the respective connectors even during this disturbance. No action required for APC Charge.

Note: If any problem persists even after the respective solution is carried out, then contact APC by Schneider Electric customer support.

Transport

The APC Charge contains Lithium-Ion batteries.

Lithium-Ion battery packs are regulated as Class 9 Miscellaneous Dangerous Goods (also known as “hazardous materials” in the United States) pursuant to the International Civil Aviation Organization (ICAO) Technical Instructions for the Safe Transport of Dangerous Goods by Air, International Air Transport Association (IATA) Dangerous Goods Regulations, the International Maritime Dangerous Goods (IMDG) Code, European Agreements concerning the International Carriage of Dangerous Goods by Rail (RID) and Road (ADR), and applicable national regulations such as the USA’s hazardous materials regulations (see 49 CFR 173.185). These regulations contain very specific packaging, labeling, marking, and documentation requirements. The regulations also require that individuals involved in the preparation of dangerous goods for transport be trained and certified on proper package preparation, labeling, marking and preparing shipping documents. The following provides information to these trained and certified individuals to support their proper shipping of this battery pack.

- The battery pack meets the requirements of the test in the United Nations (UN) Manual of Tests and Criteria, Part III, sub-section 38.3. UN38.3 Report on the battery pack is available upon request
- Original packaging is strong rigid outer packaging appropriate to its capacity and intended use. The packaging is UN specification. As a lithium ion battery pack, the unit is subject to State of Charge Restrictions (SOC) and is provided by the factory at 30% SOC.
- The battery pack meets the requirements of Packing Instructions 965, section IA of the IATA regulation.
- The battery pack = 585 Wh – 625 Wh (nominal 613.2 Wh) capacity battery pack. The battery pack weighs 12 kg and contains between 4.0 kg and 4.12 kg (nominal 4.032 kg) of lithium ion cells.
- The battery pack must not be packed in the same outer packaging, or placed in an overpack with, dangerous goods classified in Class 1 (except 1.4S), Division 2.1 (flammable gases), Class 3 (flammable liquids), Division 4.1 (flammable solids) and Division 5.1 (oxidizers).

Do the following:

1. Shut down and disconnect all connected equipment.
2. Disconnect the APC Charge from mains power.
3. Follow the shipping instructions outlined in both the *Transport* and *Service* sections of this manual.

Service

The APC Charge has no field replaceable parts. If the APC Charge requires service, do not return it to the dealer. Follow these steps:

1. Contact APC by Schneider Electric Customer Support through the APC by Schneider Electric Web site, **www.apc.com**.
 - a. Note the model number and serial number and the date of purchase. The model and serial numbers are located on the top panel of the APC Charge.
 - b. Call APC by Schneider Electric Customer Support and a technician will attempt to solve the problem over the phone.
If this is not possible, the technician will issue a Returned Material Authorization Number (RMA#).
 - c. If the APC Charge is under warranty, it will be repaired or replaced at no cost.
 - d. Service procedures and returns may vary internationally. Refer to the APC by Schneider Electric Web site for country specific instructions.
2. Pack the APC Charge properly to avoid damage in transit. Never use foam beads for packaging. Damage sustained in transit is not covered under warranty.
3. Write the RMA# provided by Customer Support on the outside of the package.
4. Return the APC Charge by insured, prepaid carrier to the address provided by Customer Support.

Limited Factory Warranty

Schneider Electric IT Corporation (SEIT), warrants its products to be free from defects in materials and workmanship for a period of three (3) years. The SEIT obligation under this warranty is limited to repairing or replacing, at its own sole option, any such defective products. Repair or replacement of a defective product or part thereof does not extend the original warranty period.

This warranty applies only to the original purchaser who must have properly registered the product within 10 days of purchase. Products may be registered online at warranty.apc.com.

SEIT shall not be liable under the warranty if its testing and examination disclose that the alleged defect in the product does not exist or was caused by end user or any third person misuse, negligence, improper installation, testing, operation or use of the product contrary to SEIT recommendations of specifications. Further, SEIT shall not be liable for defects resulting from: 1) unauthorized attempts to repair or modify the product, 2) incorrect or inadequate electrical voltage or connection, 3) inappropriate on site operation conditions, 4) Acts of God, 5) exposure to the elements, or 6) theft. In no event shall SEIT have any liability under this warranty for any product where the serial number has been altered, defaced, or removed.

EXCEPT AS SET FORTH ABOVE, THERE ARE NO WARRANTIES, EXPRESS OR IMPLIED, BY OPERATION OF LAW OR OTHERWISE, APPLICABLE TO PRODUCTS SOLD, SERVICED OR FURNISHED UNDER THIS AGREEMENT OR IN CONNECTION HERewith.

SEIT DISCLAIMS ALL IMPLIED WARRANTIES OF MERCHANTABILITY, SATISFACTION AND FITNESS FOR A PARTICULAR PURPOSE.

SEIT EXPRESS WARRANTIES WILL NOT BE ENLARGED, DIMINISHED, OR AFFECTED BY AND NO OBLIGATION OR LIABILITY WILL ARISE OUT OF, SEIT RENDERING OF TECHNICAL OR OTHER ADVICE OR SERVICE IN CONNECTION WITH THE PRODUCTS.

THE FOREGOING WARRANTIES AND REMEDIES ARE EXCLUSIVE AND IN LIEU OF ALL OTHER WARRANTIES AND REMEDIES. THE WARRANTIES SET FORTH ABOVE CONSTITUTE SEIT'S SOLE LIABILITY AND PURCHASER EXCLUSIVE REMEDY FOR ANY BREACH OF SUCH WARRANTIES. SEIT WARRANTIES EXTEND ONLY TO ORIGINAL PURCHASER AND ARE NOT EXTENDED TO ANY THIRD PARTIES.

IN NO EVENT SHALL SEIT, ITS OFFICERS, DIRECTORS, AFFILIATES OR EMPLOYEES BE LIABLE FOR ANY FORM OF INDIRECT, SPECIAL, CONSEQUENTIAL OR PUNITIVE DAMAGES, ARISING OUT OF THE USE, SERVICE OR INSTALLATION OF THE PRODUCTS, WHETHER SUCH DAMAGES ARISE IN CONTRACT OR TORT, IRRESPECTIVE OF FAULT, NEGLIGENCE OR STRICT LIABILITY OR WHETHER SEIT HAS BEEN ADVISED IN ADVANCE OF THE POSSIBILITY OF SUCH DAMAGES. SPECIFICALLY, SEIT IS NOT LIABLE FOR ANY COSTS, SUCH AS LOST PROFITS OR REVENUE, WHETHER DIRECT OR INDIRECT, LOSS OF EQUIPMENT, LOSS OF USE OF EQUIPMENT, LOSS OF SOFTWARE, LOSS OF DATA, COSTS OF SUBSTITUANTS, CLAIMS BY THIRD PARTIES, OR OTHERWISE.

NOTHING IN THIS LIMITED WARRANTY SHALL SEEK TO EXCLUDE OR LIMIT OR DEATH OR PERSONAL INJURY RESULTING FROM ITS NEGLIGENCE OR ITS FRAUDULENT MISREPRESENTATION OF TO THE EXTENT THAT IT CANNOT BE EXCLUDED OR LIMITED BY APPLICABLE LAW.

To obtain service under warranty you must obtain a Returned Material Authorization (RMA) number from customer support. Customers with warranty claims issues may access the SEIT worldwide customer support network through the APC by Schneider Electric Web site: www.apc.com. Select your country from the country selection drop down menu. Open the Support tab at the top of the web page to obtain information for customer support in your region. Products must be returned with transportation charges prepaid and must be accompanied by a brief description of the problem encountered and proof of date and place of purchase.

APC™ by Schneider Electric Worldwide Customer Support

Customer support for this or any other APC™ by Schneider Electric product is available at no charge in any of the following ways:

- Visit the APC web site to access documents in the APC by Schneider Electric Knowledge Base and to submit customer support requests.
 - **www.apc.com** (Corporate Headquarters)
Connect to localized APC web site for specific countries, each of which provides customer support information.
 - **www.apc.com/support/**
Global support searching APC by Schneider Electric Knowledge Base and using e-support.
- Contact the APC by Schneider Electric Customer Support Center by telephone or e-mail.
 - Local, country specific centers: go to **www.apc.com/support/contact** for contact information.
 - For information on how to obtain local customer support, contact the APC by Schneider Electric representative or other distributor from whom you purchased your APC by Schneider Electric product.

© 2020 APC by Schneider Electric. APC, the APC logo and Smart-UPS are owned by Schneider Electric Industries S.A.S. or their affiliated companies. All other trademarks are property of their respective owners.