

## LON Motion Detector 2.20 m

### System M

Operating instructions

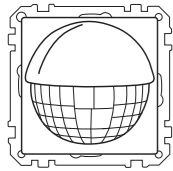

Art. no. MTN881251/MTN8312-03xx/MTN8312-04xx

### Necessary Accessories

– LON Bus Coupling Unit UP (Art. no. MTN880451)

### Accessories

– System M design frame

### For your safety

#### ⚠ DANGER

**Risk of serious damage to property and personal injury, e.g. from fire or electric shock, due to incorrect electrical installation.**

Safe electrical installation can only be ensured if the person in question can prove basic knowledge in the following areas:

- Connection to installation networks
- Connecting several electrical devices
- Laying electric cables
- Connecting and establishing LON networks

These skills and experience are normally only possessed by skilled professionals who are trained in the field of electrical installation technology. If these minimum requirements are not met or are disregarded in any way, you will be solely liable for any damage to property or personal injury.

### Getting to know the detector

The LON Motion Detector 2.20 m (referred to below as the **detector**) is a flush-mounted movement detector for indoor installation. It detects moving heat sources, e.g. people, within a radius of 180° and to a distance of approx. 8 m to the right and left and approx. 12 m to the front. The detector is designed for installation at a height of 2.20 m. A mounting height of 1.1 m is also possible, although this will halve the range. With anti-crawl protection, movement directly beneath the device is also detected.

**i** The specified ranges refer to average conditions for the recommended mounting height and are therefore guide values. The range and sensitivity can vary greatly when the temperature fluctuates.

When a movement is detected, a data telegram defined by the programming is transmitted. The ambient brightness from which the detector will detect movements can be set with the rotary switch for detection brightness. To do this, the detector is equipped with a light sensor whose brightness threshold can be set between 10 and 1000 lux. The overshoot time can be set via an additional rotary switch from 1 s up to 8 min.

Use the detector in combination with a LON bus coupler; power supply via LON.

### Using detector with alarm systems

**i** The detector is **not** suitable for use as a component of an alarm system as defined by the German insurance industry association VdS (Verband der Sachversicherer).

- Whenever the mains supply fails and recovers, the detector will switch the connected alarm, regardless of whether or not a movement is detected. This causes false alarms.
- The detector can trigger false alarms if the installation site has been chosen unfavourably.

Movement/presence detectors switch on as soon as they detect a moving heat source. This can be a person, but also animals, trees, cars or differences in temperature in windows. In order to avoid false alarms, the chosen installation site should be such that undesired heat sources cannot be detected (see section „Selecting the installation site“).

### Connections, displays and operating elements

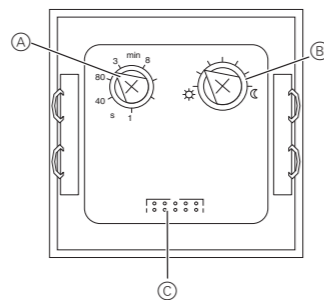

- (A) Setting: overshoot time
- (B) Setting: detection brightness
- (C) Connection pin (for bus coupler)

### Selecting the installation site

When selecting a suitable installation site, you should take a number of factors into account so that the movement detector operates optimally.

- Only mount the detector in positions which allow the required area to be monitored optimally.

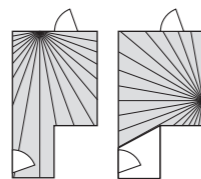

- Observe the area of detection: Install the detector on the wall at a height of approx. 2.20 m above the floor. Any mounting height which deviates from this will affect the range.
- Install the detector laterally with respect to the direction of movement so that the beam paths are intersected as vertically as possible.

- In order to ensure continuous monitoring, e.g. of a long hall, the areas of detection of the individual movement detectors have to intersect.

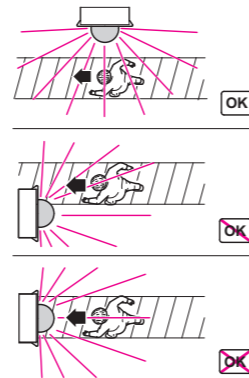

**i** The following figure shows the ranges of the detector at average temperature conditions and a mounting height of 2.20 m. The range of a movement detector can vary greatly depending on the temperature.

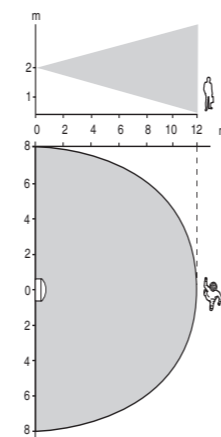

**i** Movement detectors switch on as soon as they detect a moving heat source. In order to avoid false alarms, the chosen installation site should be such that undesired heat sources cannot be detected.

Undesired sources of heat could include the following:

- moving trees, shrubbery etc. with a temperature that differs from that of their surroundings.
- windows where the influence of alternating sunlight and clouds could cause rapid changes in temperature.
- larger heat sources (e.g. cars), that are detected through windows.
- insects moving across the lens.
- small animals.
- sunlit rooms with reflecting objects (e.g. the floor), which can be the cause of rapid changes in temperature.

### Mounting the detector

You need a frame and a bus coupler to mount the detector.

- Connect the bus wire to the terminal.

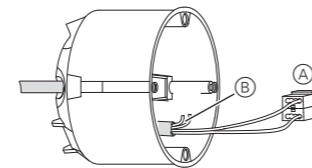

- Insert the bus terminal into the connection of bus coupler (A).
- Insert the bus coupler, flush mounted into the retaining ring.

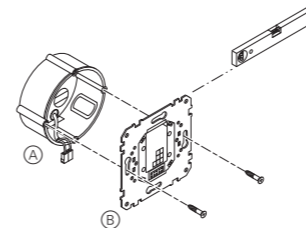

- Attach the bus coupler with the frame onto the retaining ring. Make sure that the detector clicks into place.

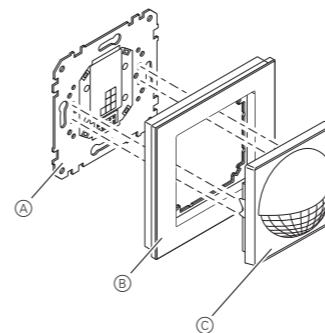

- (A) Bus coupler, flush mounted (incl. retaining ring)
- (B) Frame
- (C) Detector

#### ⚠ CAUTION

**The device may become damaged caused by bent pins**

The contact pins on the rear of the push-button can become bent if tilted excessively. Therefore always plug the push-button in as straight as possible.

### Putting the detector into operation

The commissioning process depends on the used installation tool (LonMaker™, NL220, etc). For device identification on the LONWORKS® network use the service pin of the bus coupler.

**i** Only applications permitted by Schneider Electric may be loaded onto the device.

### Setting the detector

You can set the detection brightness and overshoot time on the rear of the detector.

#### Setting the detection brightness

Here you can infinitely set the ambient brightness level at which the detector detects movements and triggers a switching procedure.

- Moon symbol (left stop): The detector will only detect movements during the hours of darkness (approx. 10 lux).
- Sun symbol: The detector detects movements up to approx. 1000 lux.
- Infinity symbol (right-hand-stop): The detector detects movements regardless of the ambient brightness.



**i** The configured brightness is a threshold value. If the current value is below the configured threshold a value of 0 lux is sent to the bus. If the current value is above the configured threshold a value of 1000 lux is sent to the bus.

#### Setting the overshoot time

With the overshoot time you specify how long the occupancy state will be kept as occupied after the last movement has been detected. There is a dependency between the hold time that can be adjusted in the software application and the overshoot time set by the rotary switch.

**i** Once the load has been switched on, the set brightness threshold is ignored. If the movement detector no longer switches off, it may be because it is continually detecting new movement and thus extending the overshoot time.

### Blocking out areas

If sources of interference (such as light sources) inadvertently switch on the connected luminaires, you can block these areas out. Adjust the area of detection of the detector by applying, moving or shortening the covering segments supplied.

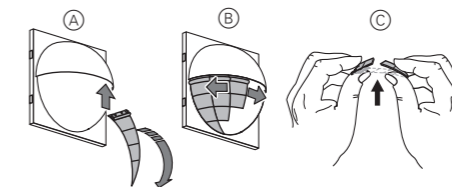

- Place the covering segment on the centre of the lens and click it into place at the top between the hood and the lens (A).
- Move the covering segments precisely onto the area which you wish to block from detection (B).
- If necessary: Shorten the covering segments at the positions marked so only the close range of the lens is used (C).

**i** Using covering segments affects the detection brightness of the detector. Readjust the detection brightness.

### Technical data

Supply:	by bus coupler
LON connection:	Bus connecting terminal
Angle of detection:	180°
Number of levels:	6
Number of zones:	46
Number of movement sensors:	2, sector-orientated
Recommended mounting height:	2.20 m
Range:	approx. 8 m right/left, approx. 12 m to the front
Detection brightness:	Infinite setting from approx. 10 lx to approx. 1000 lx (rotary switch)
Overshoot time:	Adjustable in 6 steps from approx. 1 s to approx. 8 min (rotary switch)
Operating elements:	rotary switch for detection brightness, range, and overshoot time
Ambient temperature	
Operation:	-5 °C to +45 °C
Type of protection:	IP 20
EC guidelines:	LV guideline 2006/95/EG EMC guideline 2004/108/EG

### Schneider Electric Industries SAS

If you have technical questions, please contact the Customer Care Center in your country.

www.schneider-electric.com