

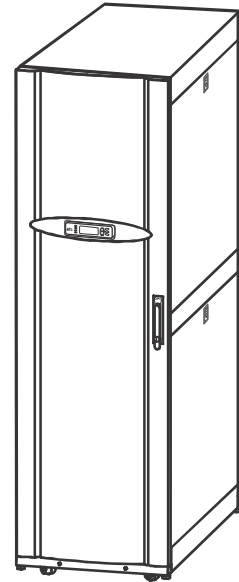

# 150/175kVA Modular PDU

## Guide for Receiving, Unpacking, and Moving



**SAVE THESE INSTRUCTIONS!**

### Receiving

When the shipment arrives, inspect the shipping material for any signs of damage or mishandling.

Do not attempt to install the system if damage is apparent. If any damage is noted, contact the shipping company within 24 hours and file a damage claim. Contact Schneider Electric Worldwide Customer Support at [www.schneider-electric.com](http://www.schneider-electric.com) for more information.

Compare the components of the shipment with the bill of lading. Report any missing items to the carrier and to Schneider Electric immediately. Verify that labeled units match the order confirmation.

### Safety Information

<b>⚠ WARNING</b>
<b>TIPPING/HEAVY EQUIPMENT HAZARD</b>
<ul style="list-style-type: none"> <li>Do not tip the enclosure more than 10° as it will cause damage to the enclosure.</li> <li>If the height of the enclosure exceeds the height of the doorway, remove the enclosure from the pallet.</li> <li>Ensure that the floor and sub-floor can support the total weight of the system, especially when the weight is concentrated on the stabilizing feet.</li> <li>Ensure that the floor is level. The enclosure cannot be installed on a floor that is not level.</li> </ul>
<b>Failure to follow these instructions can result in serious injury or equipment damage.</b>

### Space Considerations

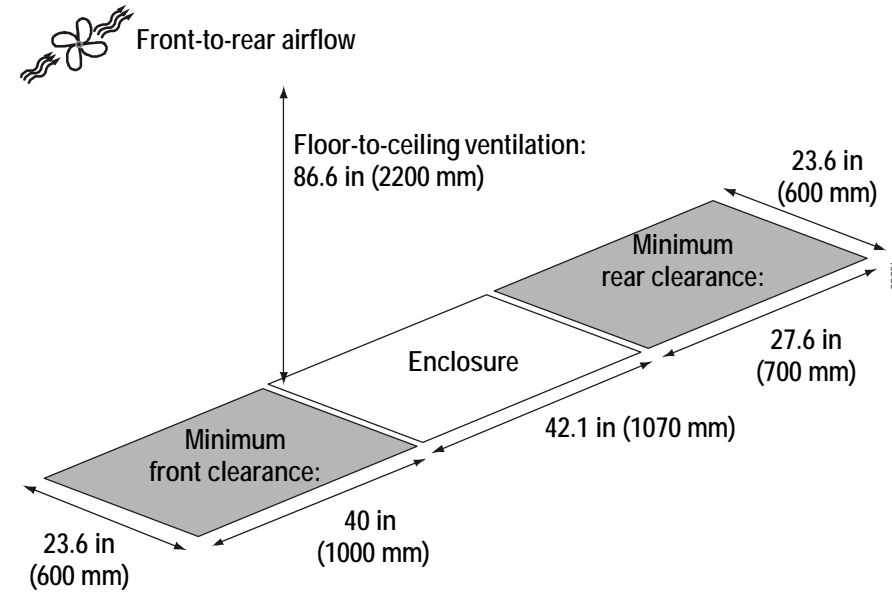

### Storage Conditions

Storage Temperature: -25° to +65°C/ -13° to +149°F	Relative Humidity: 0-95% Non-condensing	Altitude: 0-15000 m/0-50000 ft

<b>NOTICE</b>
If the system is not being installed immediately, do not remove the packaging. Store the unit in an indoor, temperature-controlled area, free of conductive contaminants.

### Tools Required (Not Provided)

Utility Knife	Level
17mm open ended wrench	13mm socket wrench

### Unpacking

<b>NOTICE</b>
<ul style="list-style-type: none"> <li>Leaving the equipment uncovered and exposed to the elements will cause damage and void the factory warranty.</li> <li>When possible, leave the equipment on the pallet until you are ready to move it to its final location.</li> </ul>



**Recyclable materials:** The shipping materials are recyclable. Save them for later use, or dispose of them appropriately.



Use a pallet jack or a forklift to move the pallets to the installation site.

- Cut the plastic wrap along the edges.

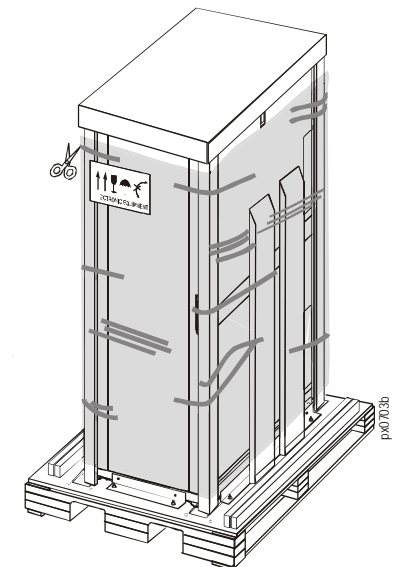

- Remove the plastic wrap and cardboard covers. Remove the ramps and set aside.

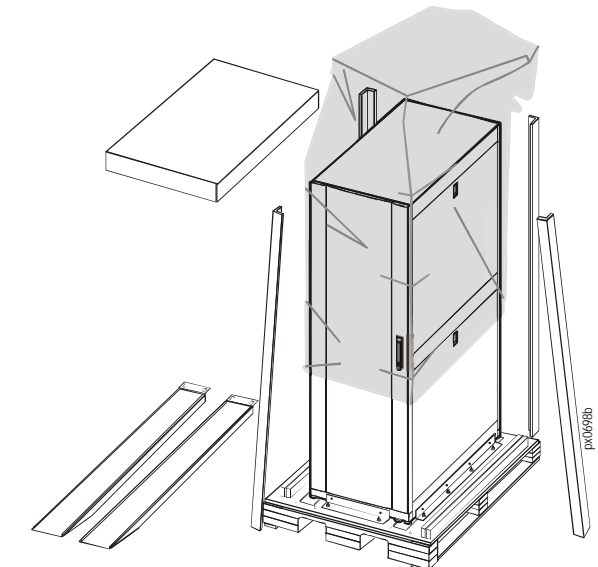

- 3 Remove the stabilizing brackets from the front, back, and sides of the enclosure.

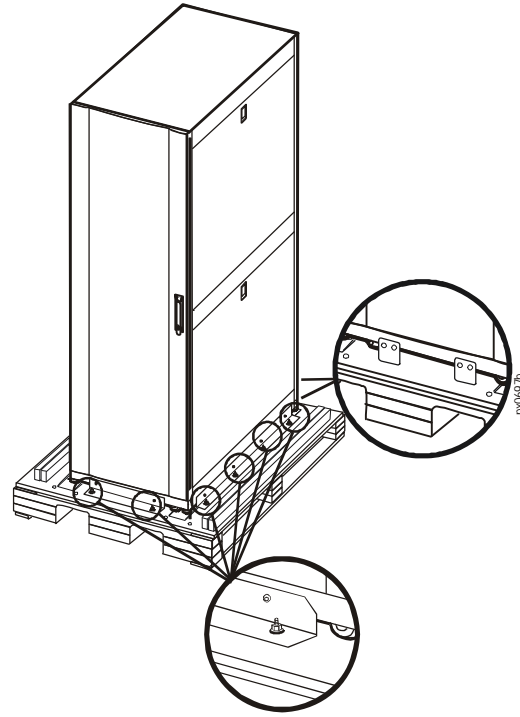

- 5 Use two people to roll the enclosure off the pallet and guide it down the ramp. Make sure that the metal tabs remain in the slots while rolling the unit off the pallet.

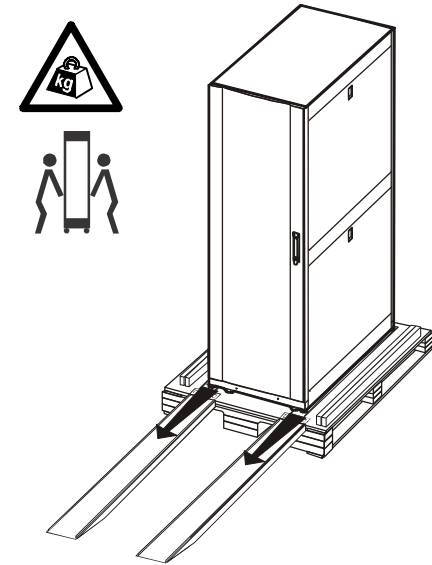

### ⚠ WARNING

#### TIPPING/HEAVY EQUIPMENT HAZARD

Risk of instability. The product could roll down the ramp too quickly, or the casters could jam into the ramp's guides, causing the product to tip over. To reduce the risk of personal injury, a minimum of two people are required to control the product as it rolls down the ramps. One person should be located on either side of the ramps. In addition, ensure a clear area around the pallet and ramps to have as an escape route in the event the product were to tip over.

**Failure to follow these instructions can result in serious injury or equipment damage.**

### ⚠ WARNING

#### TIPPING/HEAVY EQUIPMENT HAZARD

After the unit has been removed from the pallet, move it only by rolling it on the casters.

**Failure to follow these instructions can result in serious injury or equipment damage.**

- 4 Drop the metal tabs of the two ramps into the two slots near the edge of the pallet.

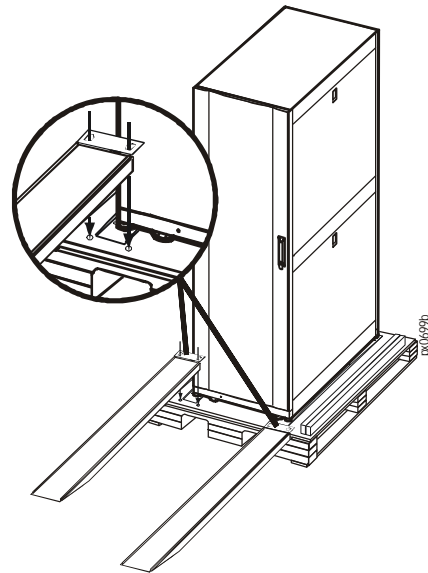

## Worldwide Customer Support

Customer support for this or any other Schneider Electric product is available at no charge in any of the following ways:

- Visit the Schneider Electric Web site to access documents in the Schneider Electric Knowledge Base and to submit customer support requests.
  - [www.schneiderelectric.com](http://www.schneiderelectric.com) (Corporate Headquarters)  
Connect to localized Schneider Electric Web sites for specific countries, each of which provides customer support information.
  - [www.schneiderelectric.com/support/](http://www.schneiderelectric.com/support/)  
Global support searching Schneider Electric Knowledge Base and using e-support.
- Contact the Schneider Electric Customer Support Center by telephone or e-mail.

For information on how to obtain local customer support, contact the Schneider Electric representative or other distributors from whom you purchased your Schneider Electric product.