

# Galaxy 7000

## Battery Breaker Box

### Installation

03/2018

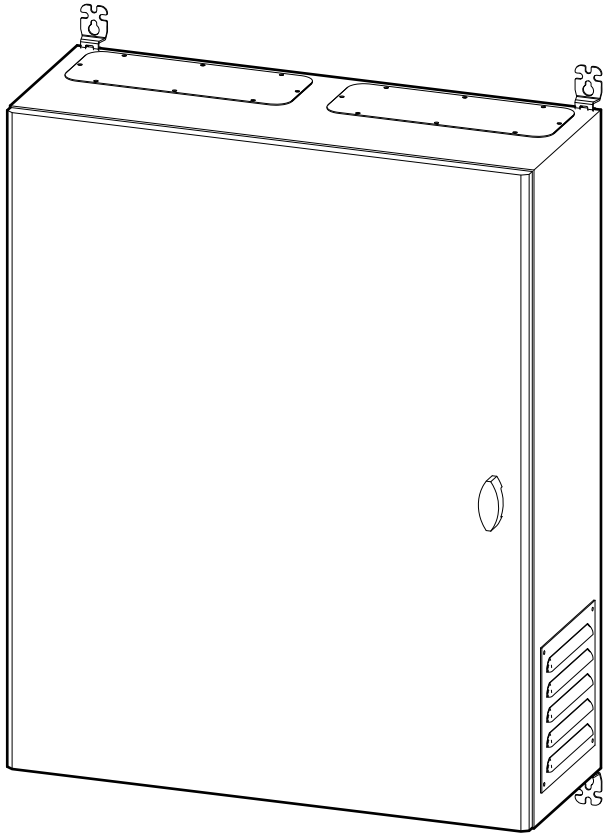

# Legal Information

The Schneider Electric brand and any registered trademarks of Schneider Electric Industries SAS referred to in this guide are the sole property of Schneider Electric SA and its subsidiaries. They may not be used for any purpose without the owner's permission, given in writing. This guide and its content are protected, within the meaning of the French intellectual property code (Code de la propriété intellectuelle français, referred to hereafter as "the Code"), under the laws of copyright covering texts, drawings and models, as well as by trademark law. You agree not to reproduce, other than for your own personal, noncommercial use as defined in the Code, all or part of this guide on any medium whatsoever without Schneider Electric's permission, given in writing. You also agree not to establish any hypertext links to this guide or its content. Schneider Electric does not grant any right or license for the personal and noncommercial use of the guide or its content, except for a non-exclusive license to consult it on an "as is" basis, at your own risk. All other rights are reserved.

Electrical equipment should be installed, operated, serviced, and maintained only by qualified personnel. No responsibility is assumed by Schneider Electric for any consequences arising out of the use of this material.

As standards, specifications, and designs change from time to time, please ask for confirmation of the information given in this publication.

---

# Table of Contents

Important Safety Instructions — SAVE THESE	
INSTRUCTIONS .....	5
Safety Precautions .....	6
Battery Breaker Box Configurations.....	8
Battery Breaker Box Weights and Dimensions .....	9
Mount the Battery Breaker Box to the Wall .....	10
Connect the Power and Signal Cables .....	11
Connect Power and Signal Cables in a Battery Breaker Box with One Battery Breaker .....	11
Connect Power and Signal Cables in a Battery Breaker Box with Two Battery Breakers.....	12
Connect Power and Signal Cables in a Battery Breaker Box with Three Battery Breakers.....	14



# Important Safety Instructions — SAVE THESE INSTRUCTIONS

Read these instructions carefully and look at the equipment to become familiar with it before trying to install, operate, service or maintain it. The following safety messages may appear throughout this manual or on the equipment to warn of potential hazards or to call attention to information that clarifies or simplifies a procedure.



The addition of this symbol to a “Danger” or “Warning” safety message indicates that an electrical hazard exists which will result in personal injury if the instructions are not followed.



This is the safety alert symbol. It is used to alert you to potential personal injury hazards. Obey all safety messages with this symbol to avoid possible injury or death.

## **DANGER**

**DANGER** indicates a hazardous situation which, if not avoided, **will result in death or serious injury**.

**Failure to follow these instructions will result in death or serious injury.**

## **WARNING**

**WARNING** indicates a hazardous situation which, if not avoided, **could result in death or serious injury**.

**Failure to follow these instructions can result in death, serious injury, or equipment damage.**

## **CAUTION**

**CAUTION** indicates a hazardous situation which, if not avoided, **could result in minor or moderate injury**.

**Failure to follow these instructions can result in injury or equipment damage.**

## **NOTICE**

**NOTICE** is used to address practices not related to physical injury. The safety alert symbol shall not be used with this type of safety message.

**Failure to follow these instructions can result in equipment damage.**

## Please Note

Electrical equipment should only be installed, operated, serviced, and maintained by qualified personnel. No responsibility is assumed by Schneider Electric for any consequences arising out of the use of this material.

A qualified person is one who has skills and knowledge related to the construction, installation, and operation of electrical equipment and has received safety training to recognize and avoid the hazards involved.

## Safety Precautions

### **⚠ DANGER**

#### **HAZARD OF ELECTRIC SHOCK, EXPLOSION, OR ARC FLASH**

All safety instructions in this document must be read, understood and followed.

**Failure to follow these instructions will result in death or serious injury.**

### **⚠ DANGER**

#### **HAZARD OF ELECTRIC SHOCK, EXPLOSION, OR ARC FLASH**

The battery breaker box is not designed for and must therefore not be installed in the following unusual operating environments:

- Damaging fumes
- Explosive mixtures of dust or gases, corrosive gases, or conductive or radiant heat from other sources
- Moisture, abrasive dust, steam or in an excessively damp environment
- Fungus, insects, vermin
- Salt-laden air or contaminated cooling refrigerant
- Pollution degree higher than 2 according to IEC 60664-1
- Exposure to abnormal vibrations, shocks, and tilting
- Exposure to direct sunlight, heat sources, or strong electromagnetic fields

**Failure to follow these instructions will result in death or serious injury.**

### **⚠ WARNING**

#### **HAZARD OF ARC FLASH**

Do not make mechanical changes to the product (including removal of cabinet parts or drilling/cutting of holes) that are not described in the Installation Manual.

**Failure to follow these instructions can result in death, serious injury, or equipment damage.**

## Electrical Safety

### **⚠ DANGER**

#### **HAZARD OF ELECTRIC SHOCK, EXPLOSION, OR ARC FLASH**

- Electrical equipment must be installed, operated, serviced, and maintained only by qualified personnel.
- The battery breaker box must be installed in a room with restricted access (qualified personnel only).
- Apply appropriate personal protective equipment (PPE) and follow safe electrical work practices.
- Turn off all power supplying the UPS system before working on or inside the equipment.
- Before working on the UPS system, check for hazardous voltage between all terminals including the protective earth.
- The UPS contains an internal energy source. Hazardous voltage can be present even when disconnected from the mains supply. Before installing or servicing the UPS system, ensure that the units are OFF and that mains and batteries are disconnected. Wait five minutes before opening the UPS to allow the capacitors to discharge.
- The UPS must be properly earthed/grounded and due to a high leakage current, the earthing/grounding conductor must be connected first.

**Failure to follow these instructions will result in death or serious injury.**

### **⚠ WARNING**

#### **HAZARD OF FIRE OR ARC FLASH**

The battery circuit breaker must be installed in close proximity to the batteries in accordance with local installation regulations.

**Failure to follow these instructions can result in death, serious injury, or equipment damage.**

# Battery Breaker Box Configurations

**⚠ DANGER**

**HAZARD OF ELECTRIC SHOCK, EXPLOSION, OR ARC FLASH**

The battery breaker box must only be used with the Galaxy 7000 UPS.

**Failure to follow these instructions will result in death or serious injury.**

**⚠ WARNING**

**HAZARD OF FIRE OR ARC FLASH**

- The battery breaker box must be connected as described in this manual.
- The undervoltage coil must be wired to the UPS as shown on the diagrams.

**Failure to follow these instructions can result in death, serious injury, or equipment damage.**

The below battery solutions can be made of several strings in parallel. All strings must be identical: same element block and the same number of blocks.

The below battery configurations and settings are based on nominal power at a power factor of 0.9 and 264 lead battery cells. For other battery configurations please contact Schneider Electric.

## Battery Configurations with One Battery Breaker (QF1)

UPS	Battery Backup Time Minutes	QF1 (NSX500S TM-DC)	
		Battery Strings	Thermal/Magnetic Setting (A)
250 kVA	< 90	1	500/1250
300 kVA	< 10	1	500/1250

## Battery Configurations with Two Battery Breakers (QF1)

UPS	Battery Backup Time Minutes	Total Number of Battery Strings	QF1-1 (NSX500S TM-DC)		QF1-2 (NSX500S TM-DC)	
			Battery Strings	Thermal/Magnetic Setting (A)	Battery Strings	Thermal/Magnetic Setting (A)
250 kVA	Any	2	1	500/1250	1	500/1250
		3	2	500/1250	1	500/1250
		4	2	500/1250	2	500/1250
		5	3	500/1250	2	500/1250
		6	3	500/1250	3	500/1250
300 kVA	Any	2	1	500/1250	1	500/1250
		3	2	500/1250	1	500/1250
		4	2	500/1250	2	500/1250
		5	3	500/1250	2	500/1250
		6	3	500/1250	3	500/1250
400 kVA	< 90	2	1	500/1250	1	500/1250



UPS	Battery Backup Time Minutes	Total Number of Battery Strings	QF1-1 (NSX500S TM-DC)		QF1-2 (NSX500S TM-DC)	
			Battery Strings	Thermal/Magnetic Setting (A)	Battery Strings	Thermal/Magnetic Setting (A)
		4	2	500/1250	2	500/1250
		6	3	500/1250	3	500/1250
500 kVA	< 20	2	1	500/1250	1	500/1250
		4	2	500/1250	2	500/1250
		6	3	500/1250	3	500/1250

### Battery Configurations with Three Battery Breakers (QF1)

UPS	Battery Backup Time Minutes	Total Number of Battery Strings	QF1-1 (NSX500S TM-DC)		QF1-2 (NSX500S TM-DC)		QF1-3 (NSX500S TM-DC)	
			Battery Strings	Thermal/Magnetic Setting (A)	Battery Strings	Thermal/Magnetic Setting (A)	Battery Strings	Thermal/Magnetic Setting (A)
400 kVA	Any	3	1	500/1250	1	500/1250	1	500/1250
		5	2	500/1250	2	500/1250	1	500/1250
500 kVA	Any	3	1	500/1250	1	500/1250	1	500/1250
		5	2	500/1250	2	500/1250	1	500/1250
		6	2	500/1250	2	500/1250	2	500/1250

### Battery Breaker Box Weights and Dimensions

	Weight kg	Height mm	Width mm	Depth mm
With one breaker	35	800	600	250
With two breakers	65	1000	800	300
With three breakers	75	1000	800	300

# Mount the Battery Breaker Box to the Wall

## ⚠ CAUTION

### RISK OF INJURY OR EQUIPMENT DAMAGE

- Mount the battery breaker box to a wall or a rack that is structurally sound and able to support the weight of the unit.
- Use hardware appropriate for the type of wall to mount the battery breaker box to the wall.

**Failure to follow these instructions can result in injury or equipment damage.**

**Battery Breaker Box with One Breaker**

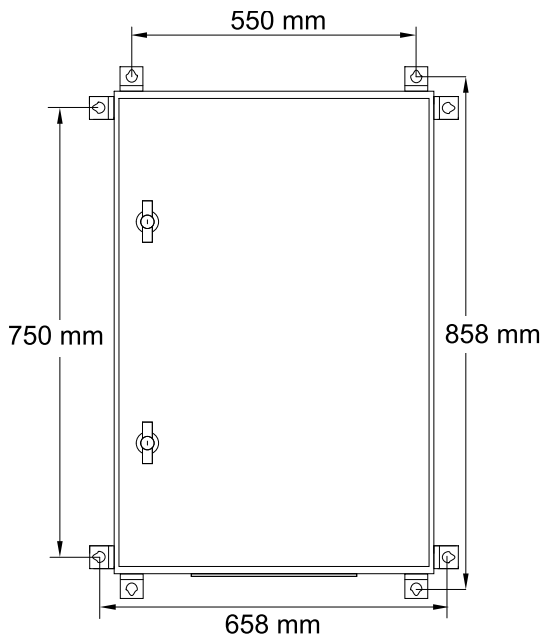

**Battery Breaker Box with Two/Three Breakers**

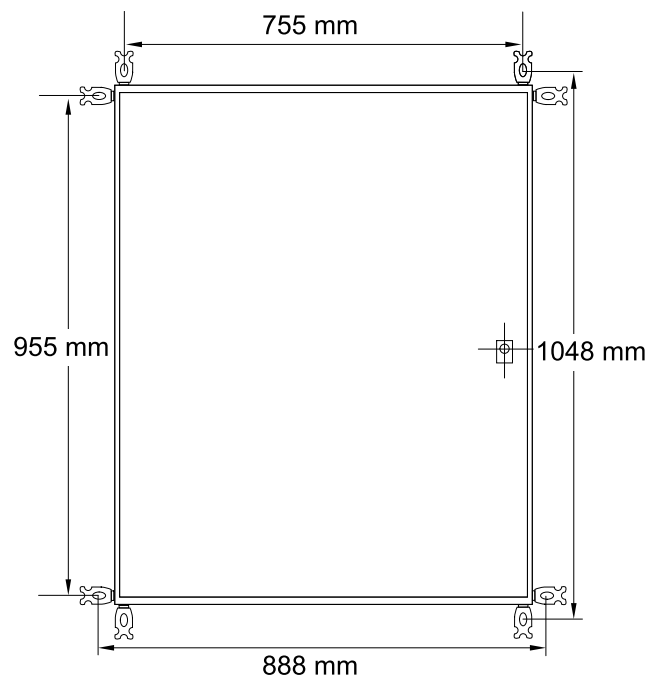

1. Measure and mark the four mounting hole locations on the wall.
2. Drill holes in each of the four marked locations.
3. Lift the battery breaker box, position it against the wall and line it up with the four holes. Fasten with four M8 screws.

## Connect the Power and Signal Cables

### ⚠ DANGER

#### HAZARD OF ELECTRIC SHOCK, EXPLOSION, OR ARC FLASH

- The battery cables between the UPS and the battery breaker must be connected according to the specifications in the UPS installation manual.
- The battery cables between the batteries and the battery breaker must be defined according to the breaker specifications in order to protect the cables.

**Failure to follow these instructions will result in death or serious injury.**

## Connect Power and Signal Cables in a Battery Breaker Box with One Battery Breaker

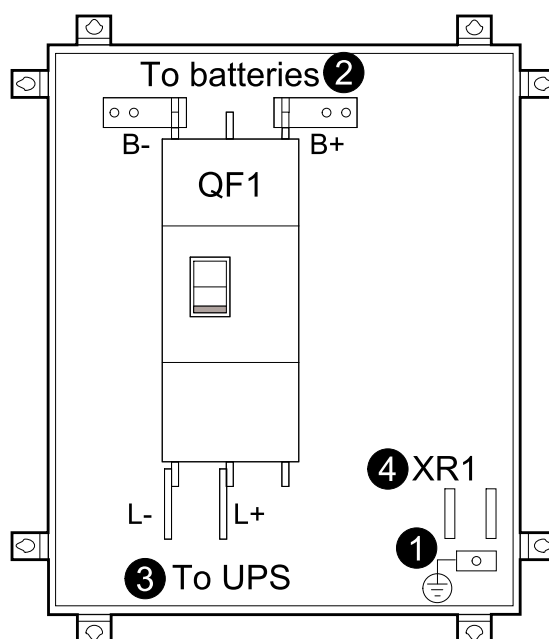

1. Connect the equipment earthing conductor.
2. Route the cables from the batteries through the bottom of the battery breaker box and connect.
3. Route the cables from the UPS through the bottom of the battery breaker box and connect.

- Connect the signal cables from the XM20 connector on the EXPUT board in the UPS to the XR1 terminal block in the battery breaker box.

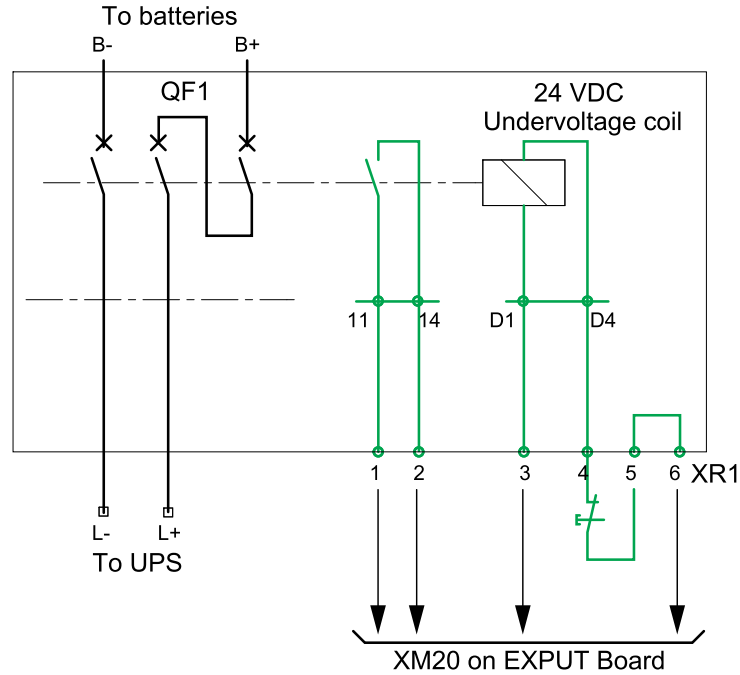

**NOTE:** Route the signal cables (SELV) separate from the power cables.

**NOTE:** Recommended cable sizes for signal cables: 1 mm<sup>2</sup>/AWG18 (2 mm<sup>2</sup>/AWG16).

- Set the QF1 breaker in the open (off) position.

## Connect Power and Signal Cables in a Battery Breaker Box with Two Battery Breakers

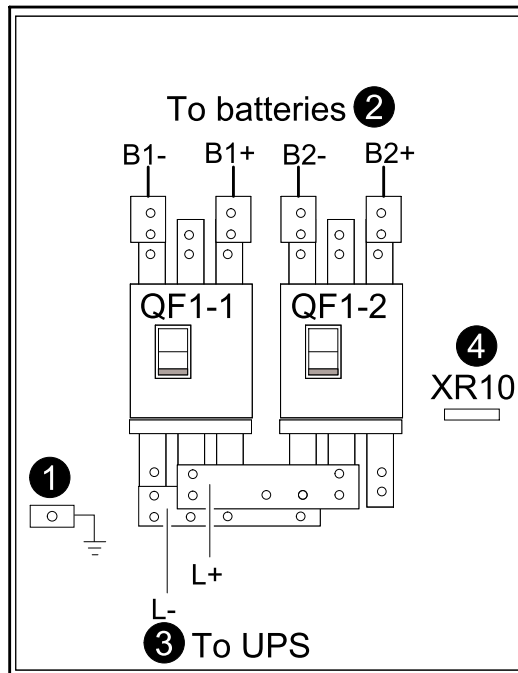

- Connect the equipment earthing conductor.
- Route the cables from the batteries through the bottom of the battery breaker box and connect.

3. Route the cables from the UPS through the bottom of the battery breaker box and connect.
4. Connect the signal cables from the XM20 connector on the EXPUT board in the UPS to the XR10 terminal block in the battery breaker box.

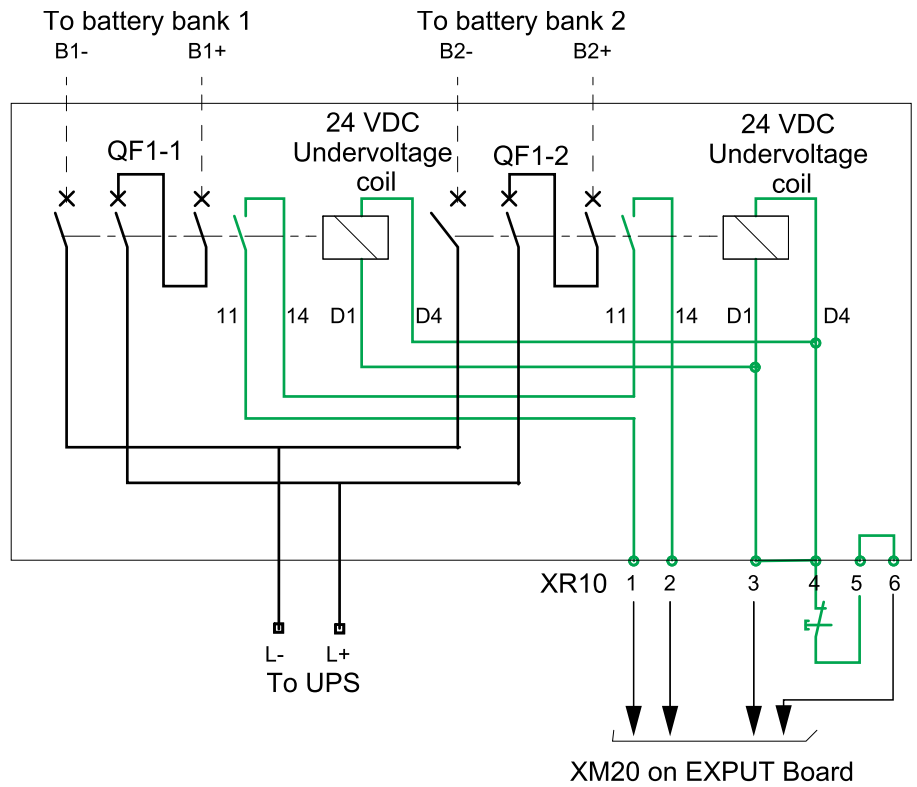

**NOTE:** Route the signal cables (SELV) separate from the power cables.

**NOTE:** Recommended cable sizes for signal cables: 1 mm<sup>2</sup>/AWG18 (2.5 mm<sup>2</sup>/AWG16).

5. Set the QF1 breakers in the open (off) position.

## Connect Power and Signal Cables in a Battery Breaker Box with Three Battery Breakers

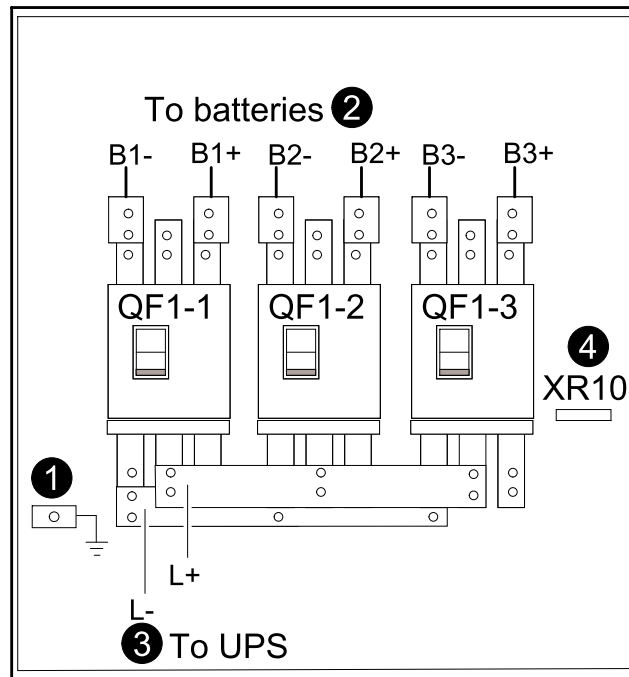

1. Connect the equipment earthing conductor.
2. Route the cables from the batteries through the bottom or top of the battery breaker box and connect.

**NOTE:** If there are more than two cables per connection, the cables should be routed through the top of the cabinet.

3. Route the cables from the UPS through the bottom of the battery breaker box and connect.

- Connect the signal cables from the XM20 connector on the EXPUT board in the UPS to the XR10 terminal block in the battery breaker box.

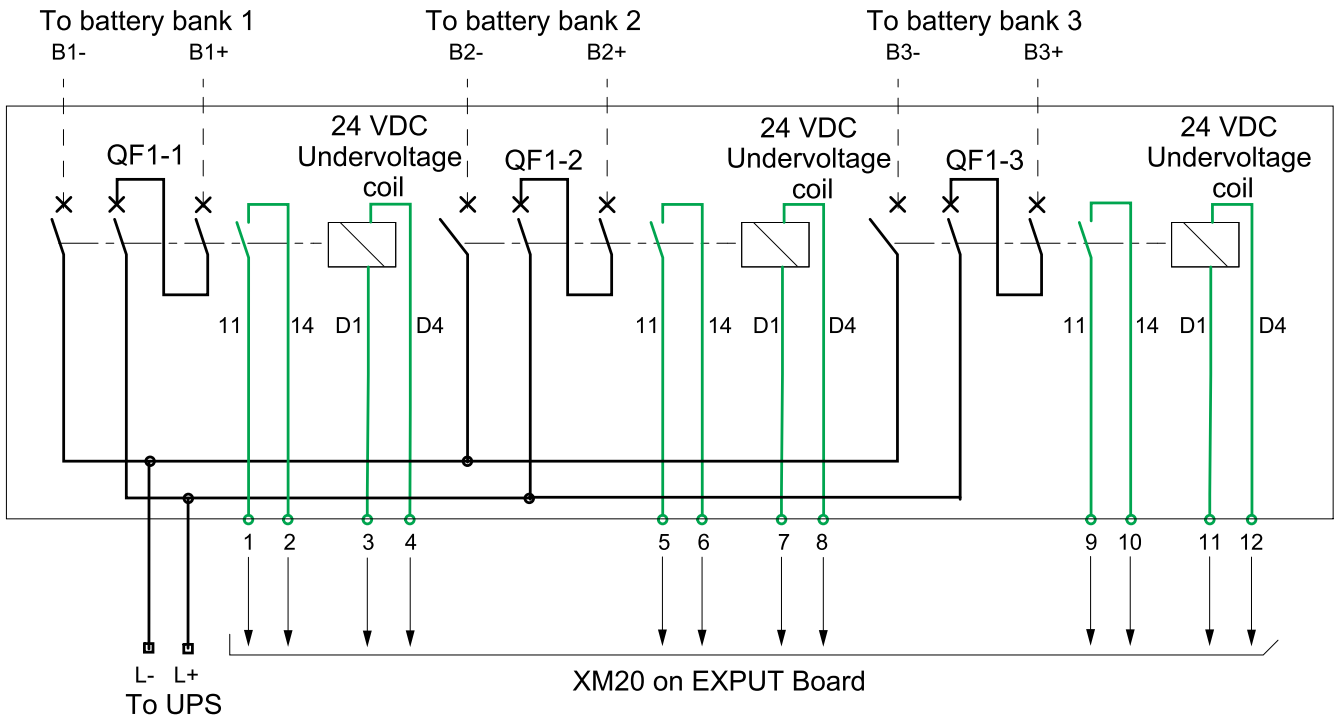

**NOTE:** Route the signal cables (SELV) separate from the power cables.

**NOTE:** Recommended cable sizes for signal cables: 1 mm<sup>2</sup>/AWG18 (2.5 mm<sup>2</sup>/AWG16).

- Set the QF1 breakers in the open (off) position.

Schneider Electric  
35 rue Joseph Monier  
92500 Rueil Malmaison  
France

+ 33 (0) 1 41 29 70 00

[www.schneider-electric.com](http://www.schneider-electric.com)

As standards, specifications, and design change from time to time,  
please ask for confirmation of the information given in this publication.

© 2017 – 2018 Schneider Electric. All rights reserved.

990-9993B-001