

User Manual Back-UPS™ BX600LI-MS

Important Safety Information

Read the instructions carefully to become familiar with the equipment before trying to install, operate, service or maintain it. The following special messages may appear throughout this manual or on the equipment to warn of potential hazards or to call attention to information that clarifies or simplifies a procedure.



The addition of this symbol to a Danger or Warning safety label indicates that an electrical hazard exists which will result in personal injury if the instructions are not followed.



This is the safety alert symbol. It is used to alert you to potential personal injury hazards. Obey all safety messages that follow this symbol to avoid possible injury or death.

WARNING

WARNING indicates a potentially hazardous situation which, if not avoided, **can result in death or serious injury**.

CAUTION

CAUTION indicates a potentially hazardous situation which, if not avoided, **can result in minor or moderate injury**.

CAUTION

CAUTION addresses practices not related to physical injury including certain environmental hazards, potential damage or loss of data.

Inventory

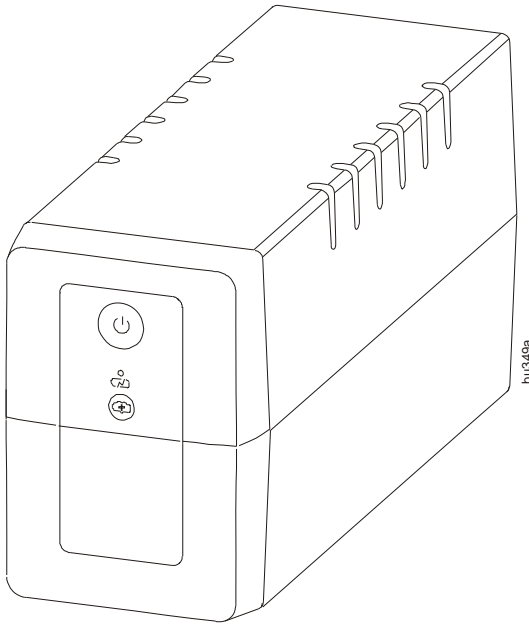

Utility power cable

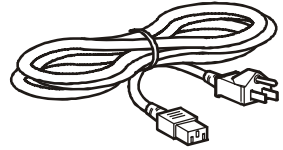

Safety and General Information

- This unit is intended for indoor use only.
- Do not operate this unit in direct sunlight, in contact with fluids, or where there is excessive dust or humidity.
- Be sure the air vents on the UPS are not blocked. Allow adequate space for proper ventilation.
- Environmental factors impact battery life. Elevated ambient temperatures, poor quality utility power, and frequent short duration discharges will shorten battery life.
- Connect the Back-UPS power cable directly to a wall outlet. Do not use surge protectors or extension cords.

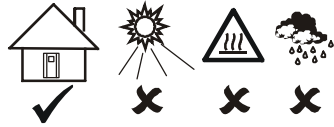

Auto frequency selection

The UPS is designed to sync the output frequency to 50/60 Hz as sensed from the input utility power. The default factory setting is 50 Hz.

Connect the UPS to the utility power, before switching it to battery power, to sync the output frequency. Perform this one time activity when UPS is operated for the first time

CAUTION

HAZARD OF EQUIPMENT DAMAGE

Connect the UPS to the utility power, before switching it to battery power, to sync the output frequency. If the frequency is not synced, the connected equipment can be damaged due to incorrect operating frequency.

Failure to follow these instructions will result in equipment damage.

Installation

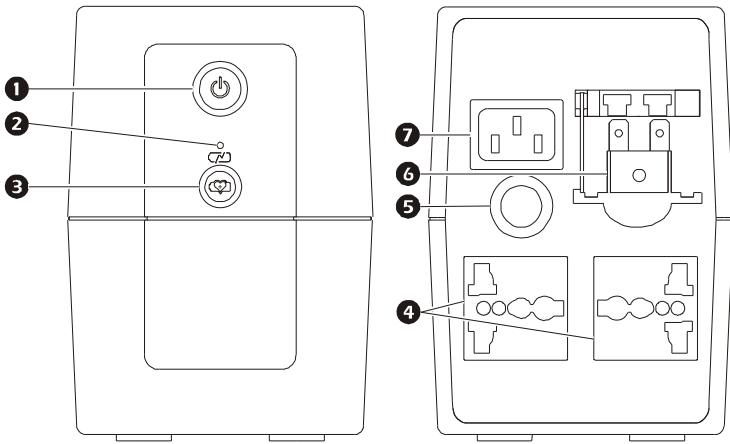

bu371a

<p>1</p>	<p>POWER ON/OFF button and LED</p>	<p>Use to switch the UPS on or off. The LED illuminates green to indicate that power is supplied to the connected equipment both on mains and on battery. The LED illuminates red to indicate errors.</p>
<p>2</p>	<p>Charging LED</p>	<p>The LED illuminates to indicate the battery is charging. Once the battery is charged, the LED will turn off.</p>
<p>3</p>	<p>BATTERY SAVER button and LED</p>	<p>Press the BATTERY SAVER button to activate the battery saver feature. Green LED will illuminate to indicate the UPS is working in the battery saver mode. This feature helps the UPS to offer consistent runtime during the lifetime of the battery. It increases battery life up to two times. Runtime of the connected equipment will reduce when this feature is enabled. See also “No Load Shutdown” on page 6.</p>
<p>4</p>	<p>Battery backup plus surge arrest outlets</p>	<p>These outlets help provide battery backup power to the connected equipment for a limited period of time during power outages and voltage fluctuations. The Battery Backup outlets provide battery power to connected equipment only when the Back-UPS is turned on. Connect equipment such as desktop computer, computer monitor, modem or other data sensitive devices to these outlets. Note: Connect equipment to these outlets using a standard molded 6 A plug. Do not use surge protectors or extension cords.</p>
<p>5</p>	<p>Fuse</p>	<p>User replaceable fuse. Helps to protect the UPS in case of an overload condition. See “Troubleshooting” on page 9 for details.</p>

6	Battery connector	Used to connect the internal battery of the UPS. See “Connect the battery” on page 5.
7	Utility power cable	Connect the Back-UPS power cord to the outlet on the back of the unit and to a wall outlet. Do not connect the power cord to a surge protector or power strip. The wall outlet should be near the equipment and easily accessible.

Connect the battery

Pull the battery connector handle down, and then push it into the unit.

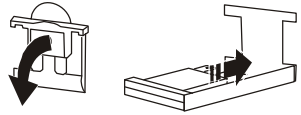

Turn On the Back-UPS

Press the **POWER ON/OFF** button located on the front panel of the Back-UPS. The **Power On/Off LED** will illuminate and a single long beep will be audible to indicate that the Back-UPS is providing protection for the connected equipment.

The Back-UPS battery charges to capacity during the first 10 hours while connected to the utility power. The Back-UPS battery will charge while the Back-UPS is turned on or off and as long as it is connected to utility power. Do not expect the battery to run for its expected capacity during the initial charge period.

Battery Replacement

⚠ WARNING
HAZARD OF EXPLOSION
Do not dispose of the batteries in a fire. The batteries may explode. Do not open or mutilate the batteries. Released electrolyte may be toxic and it is harmful to the skin and eyes.
Failure to follow these instructions can result in death or serious injury

The battery in the Back-UPS is not user replaceable. Contact APC by Schneider Electric Sales and Technical Support for a list of authorized service centers.

Transfer Voltage

Voltage regulation

The Back-UPS will switch to battery power if the utility input voltage level goes out of range or if the utility power is experiencing voltage fluctuations.

No Load Shutdown

This feature works when the **battery saver** mode is enabled in the Back-UPS on battery. The Back-UPS will shutdown if it cannot sense power is being drawn from the outlets for more than 5 minutes.

Disable this feature if low power consuming equipment like ADSL-modem or wi-fi router is connected to the Back-UPS.

Specifications

Input	Voltage	230 VAC nominal
	Frequency	45 - 65 Hz
	Under-voltage Transfer	145 VAC
	Over-voltage Transfer	290 VAC
Output	UPS Capacity (max)	600 VA/300 W
	Transfer Time	4 - 8 ms, typical
	Frequency	50/60 Hz
Protection and Filtering	Utility Input Surge Protection	Full time, 160 joules
	Overload	Fuse
Battery	Type (maintenance-free)	12 V, 7.2 Ah
	Typical Recharge Time	4 to 6 hours typical, 10 hours maximum
Physical	Net Weight	4.9 kg
	Dimensions (H x W x D)	14.2 cm × 10.0 cm × 28.3 cm
	Operating Temperature	0°C to 40°C (32°F to 104°F)*
	Storage Temperature	-15°C to 45°C (5°F to 113°F)
	Operating Relative Humidity	0 to 95% non-condensing
	Operating Elevation	0 to 3000 m (0 to 10,000 ft)
	2 power outlets	With battery backup and surge protection
	Power Cord	1.2 meters

* The battery life is reduced if it is continuously operated in temperatures more than 25°C.

Status Indicators

Visual indicator	Audible indicator	Condition
Power on/off LED		
Illuminates Green	None	Power On -The Back-UPS is supplying utility power to the connected equipment.
	Starts after 40 seconds delay. 2 quick beeps at the start and 1 beep every 40 seconds	On Battery - The Back-UPS is supplying battery power to the connected equipment.
Flashes Green	1 beep every second	Low Battery - The Back-UPS is supplying battery power to the connected equipment and the battery is near a total discharge state. The Back-UPS has less than 2 minutes of runtime remaining before shutdown.
Flashes Green for approximately 30 seconds and then shuts off	Long beep for 4 sec before UPS shutdown	Low Battery Shutdown - During on battery operation the battery is at a complete discharge state and the Back-UPS stops providing output power. Once utility power is restored the Back-UPS will return to normal operation. Press POWER ON/OFF button to return to normal operation if the Back-UPS does not return to this status.
Illuminates green for 10 seconds and illuminates red for 2 seconds alternately	Constant tone for 2 seconds followed by 40 seconds gap	Replace Battery - Battery is at the end of its life and needs to be replaced. Contact APC by Schneider Electric Technical Support.

Visual indicator	Audible indicator	Condition
Flashes Red	Beeps every 2 seconds for 30 seconds and the UPS is shutdown.	<p>On Battery Overload - While operating on battery power the connected equipment draws more power than the battery capacity can provide. Disconnect non-essential equipment, one device at a time until the overload condition has been corrected. If the problem persists, contact APC by Schneider Electric Technical Support.</p>
		<p>Online Overload - Power drawn by the load from the UPS exceeds the capacity of unit. Disconnect non-essential equipment, one device at a time until the overload condition is corrected.</p>
		<p>Temperature error - The UPS is over heated. UPS may shutdown if this error is not corrected. Disconnect non-essential equipment to correct this error. Note: The UPS will beep and the red LED will illuminate till the internal temperature comes down below the threshold level.</p>
		<p>Short circuit error - The UPS is on battery and short circuit occurs at output. Disconnect one device at a time to check if the condition can be corrected. If problem persists, contact APC by Schneider Electric Technical Support.</p>
Illuminates Red	Constant tone	Internal error - The UPS experiences an internal error and no longer provides power to the connected equipment. Contact APC by Schneider Electric Technical Support.
Charging LED		
Illuminates green	None	Battery charging - The UPS battery is charging.
Not illuminated	None	Battery fully charged - The UPS battery is charged to capacity.
Battery saver LED		
Illuminates green	None	Battery saver mode - The UPS is working in the battery saver mode.

Troubleshooting

Problem	Possible Cause	Corrective Action
The Back-UPS will not turn on.	The Back-UPS is not connected to utility power.	Be sure that the Back-UPS is securely connected to the utility power outlet.
	The fuse has blown.	Remove the UPS from mains, disconnect nonessential equipment from the Back-UPS. Replace the fuse on the rear panel. Reconnect equipment one at a time. If the fuse blows again, disconnect the device that caused the short circuit. Press POWER ON/OFF button to supply power to the connected equipment.
	The battery connector is not connected.	Connect the battery connector. See “Connect the battery” on page 5.
The Back-UPS is operating on battery power, while connected to utility power.	<ul style="list-style-type: none"> • The Back-UPS power cable is not securely connected to the wall outlet. • The wall outlet is no longer receiving utility power. • The fuse has blown. 	<ul style="list-style-type: none"> • Verify that the power cable plug is securely connected to the wall outlet. • Verify that the wall outlet is receiving utility power by checking it with another device. • Replace the fuse on the rear panel.
	The Back-UPS is performing an automatic self test.	No action is necessary. The Back-UPS will complete self test and work on mains within 11 seconds.
	<ul style="list-style-type: none"> • The utility input voltage is out of range. • The frequency is out of range. • The waveform is distorted. 	If the voltage is beyond acceptable range of 145 V to 290 V or the frequency is beyond acceptable range of 45-65 Hz, then UPS will switch to battery. No action is required.
The Back-UPS does not provide the expected amount of backup time.	The UPS battery is weak due to a recent power outage or is near the end of its service life.	Allow the Back-UPS battery to charge for 8-10 hours before using the Back-UPS. The battery requires recharging after an extended outage. Elevated ambient temperatures, poor quality utility power, and frequent short duration discharges will shorten battery life.

Problem	Possible Cause	Corrective Action
Connected equipment loses power.	The Back-UPS has experienced an overload condition.	Disconnect non-essential equipment one device at a time to reduce the overload condition.
	The Back-UPS has exhausted its available battery power.	The Back-UPS can operate on battery power for a limited amount of time. The Back-UPS will shut down when the available battery power has been exhausted. Allow the Back-UPS battery to charge for 8-10 hours before using the Back-UPS.
	The equipment connected to the Back-UPS does not accept the step approximated sine waveform from the unit.	The output waveform is designed for computers and computer-related equipment. It is not designed for use with motor-type equipment.
	The Back-UPS may require service.	Contact APC by Schneider Electric Technical Support for further troubleshooting.

Warranty

The standard warranty is one (1) year from the date of purchase. Schneider Electric IT (SEIT) standard procedure is to replace the original unit with a factory reconditioned unit. Customers who must have the original unit back due to the assignment of asset tags and set depreciation schedules must declare such a need at first contact with an SEIT Technical Support representative. SEIT will ship the replacement unit once the defective unit has been received by the repair department, or cross ship upon the receipt of a valid credit card number. The customer pays for shipping the unit to SEIT. SEIT pays ground freight transportation costs to ship the replacement unit to the customer.

Service

If the unit requires service, do not return it to the dealer. Follow these steps:

1. Review the *Troubleshooting* section of the manual to eliminate common problems.
2. If the problem persists, contact APC by Schneider Electric Customer Support through the APC by Schneider Electric Web site, **www.apc.com**.
 - a. Note the model number and serial number and the date of purchase. The model and serial numbers are located on the rear panel of the unit and are available through the LCD display on select models.
 - b. Call APC by Schneider Electric Customer Support and a technician will attempt to solve the problem over the phone. If this is not possible, the technician will issue a Returned Material Authorization Number (RMA#).
 - c. If the unit is under warranty, the repairs are free.
 - d. Service procedures and returns may vary internationally. Refer to the APC by Schneider Electric Web site for country specific instructions.
3. Pack the unit in the original packaging whenever possible to avoid damage in transit. Never use foam beads for packaging. Damage sustained in transit is not covered under warranty.
4. **Always DISCONNECT THE UPS BATTERIES before shipping. The United States Department of Transportation (DOT), and the International Air Transport Association (IATA) regulations require that UPS batteries be disconnected before shipping.** The internal batteries may remain in the UPS.
5. Write the RMA# provided by Customer Support on the outside of the package.
6. Return the unit by insured, pre-paid carrier to the address provided by Customer Support.

APC by Schneider Electric IT Worldwide Customer Support

Go to the APC by Schneider Electric Web site, www.apc.com for country specific customer support.

