

FRS923 Supply air station

1 GENERAL

Pneumatic transmitters, controllers and associated equipment can only function efficiently when provided with an air supply which is dust-, oil- and moisture-free. The supply air pressure has also to be maintained within close limits, unaffected by changes in the rate of consumption.

As the air is frequently taken from a source subject to fluctuations in pressure, a supply air station provides the necessary filtration and control to the desired pressure.

2 CONSTRUCTION

The supply air station is essentially composed of

- 1 air filter
 - 2 pressure reducer and
 - 3 pressure gauge.
- The air filter can, however, be supplied as a separate unit, as can also the pressure reducer with gauge. The air filter comprises the
- 4 aluminum bowl with
 - 5 drain screw
 - 6 plastic swirl vanes
 - 7 sintered metal filter and
 - 8 securing disc.

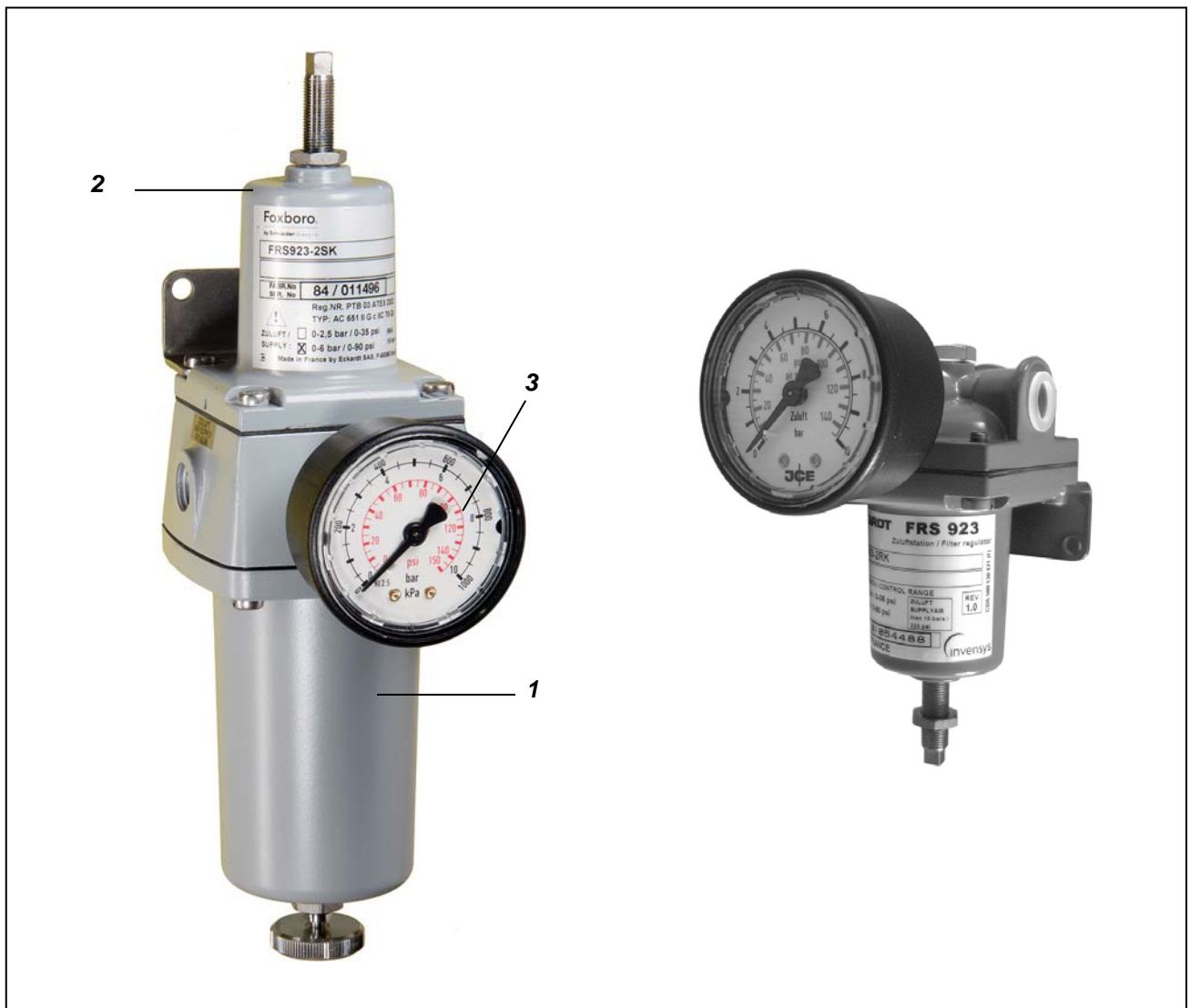

Repairs and maintenance must be carried out by qualified personnel !

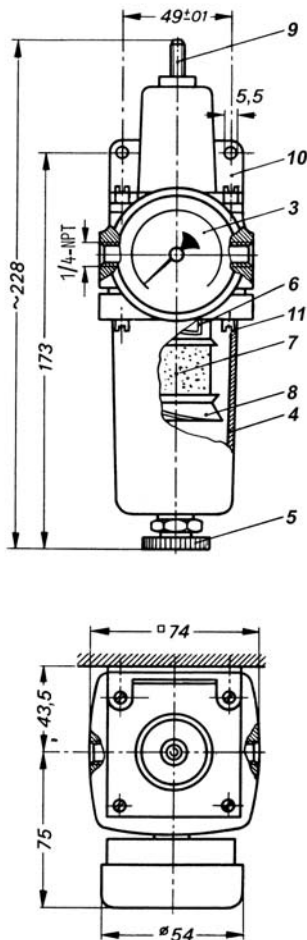

3 METHOD OF OPERATION

The stream of compressed air entering the aluminum bowl (4) is caused to form a vortex by the swirl vanes (6), with the effect that oil and water droplets are forced outwards against the aluminum bowl, and then fall to the bottom. Drain screw (5) permits the accumulated liquid to be periodically removed. Before the air reaches the pressure reducer, it is forced through the sintered metal filter (7) by the upstream pressure, to ensure elimination of solid particles. The desired output pressure can be set by adjusting 9 Spindle and the pressure read off at the gauge (3).

4 INSTALLATION

The unit should be installed with the pressure reducer upright, as close as possible to the pneumatic equipment being supplied, and ensuring that the unit will not be subject to vibration.

10 Fixing bracket is provided for mounting the unit. A clear space of at least 70 mm should be allowed beneath the supply air station to permit easy removal of the aluminum bowl.

The unit should be shielded from the direct rays of the sun, and suitable measures taken to protect against temperatures below 0° C, as otherwise the air vent passage can freeze up and adversely affect the performance of the unit.

1/4 -NPT tapped connections are provided. The necessary connectors for attaching to pipes of 6, 10 or 12 mm diameter are supplied loose with the unit, and should be screwed in during installation.

5 MAINTENANCE

5.1 DRAINING CONDENSED LIQUID

The condensed liquid should normally be drained off at weekly intervals. This is carried out by opening drain screw (5) a small amount, so that the liquid is forced out by compressed air. When all the liquid has been expelled, the drain screw (5) should be re-tightened. If the condensed liquid accumulates rapidly, draining should be carried out at more frequent intervals.

5.2 CLEANING OF FILTER ELEMENT

- Drain off condensed liquid as per section 5.1.
- Shut off the air supply to the unit, remove **11** fixing screws and remove aluminum bowl (4).
- Remove securing disc (8) and draw off filter element (7) which should then be washed in cleaning spirit and subsequently blown dry with a blast of compressed air.
- Replace filter element (7) and tighten in position by securing disc (8).
- Refit aluminum bowl (4) with gasket by means of screws (11).
- Close drain screw (5) and restore air supply.