

SRI990 模拟阀门定位器

Analog Positioner



快速指导..... (中文版)

Quick Guide.....(English)

SRI990 模拟阀门定位器

此说明书是用于使定位器快速启动的指导。如果需要更多具体的信息，请参见标准文件“主说明书”和“产品规格单”。这些文件可以在我公司的网站找到。

1. 安装到执行机构上

在操作中，定位器背后的轴 9 的平面必须总是面向箭头 26。围绕此方向的操作角度是±45°。

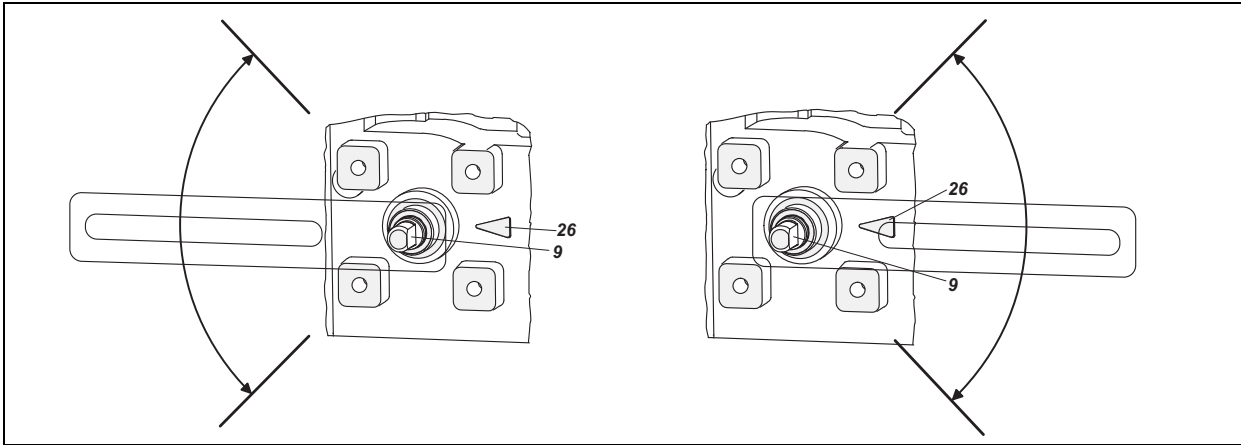

1.1 安装到线形执行机构上

NAMUR 标准安装

- 左侧 -

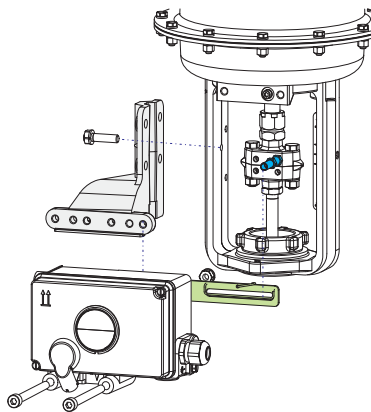

直接安装

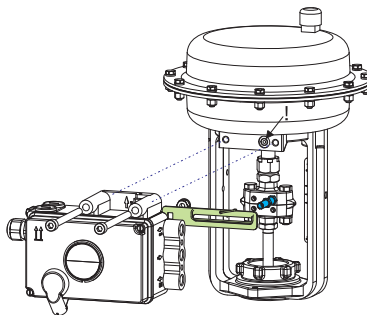

NAMUR 标准安装

- 右侧 -

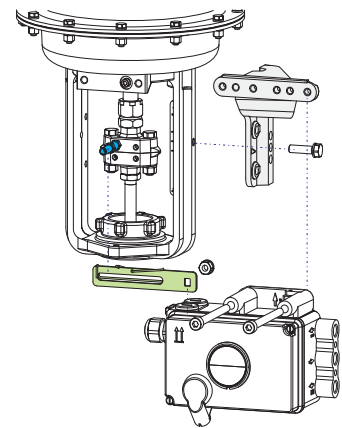

用于线形执行机构的反馈杆:

承载螺栓B在反馈杆A的长孔之中，并且补偿弹簧要接触到承载螺栓。

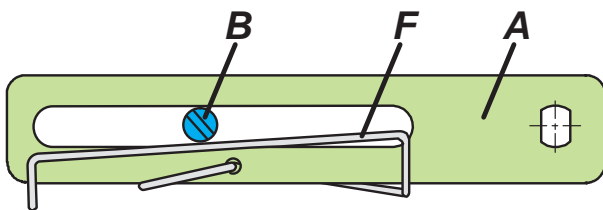

承载螺栓 B:

- 1 螺套
- 2 柱头螺栓
- 3 接合件

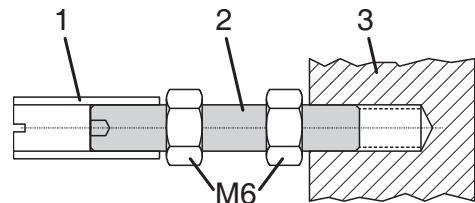

- 不要将埋头螺钉 4 与轴 9 的螺纹拧紧。
- 当在使用中，轴 9 的平面必须在箭头 26 的前面移动(0 ↔ 100%)。
- 当产品的温度上升时，传动轴1的长度增加。因此，必须安装旋转适配器3，以便于在传动轴1和旋转适配器3之间留有大约1mm(0.04in.)的间隙。在安装旋转适配器之前，通过在反馈杆9上加上适当数量的垫圈5来实现此目的。

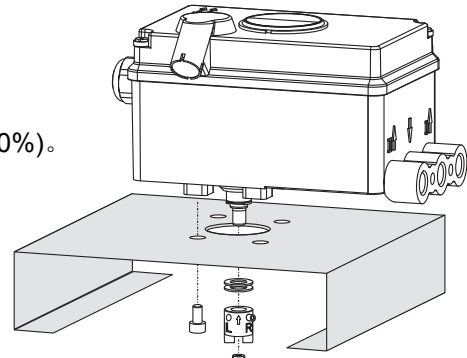

执行机构, 向左旋转

执行机构, 向右旋转

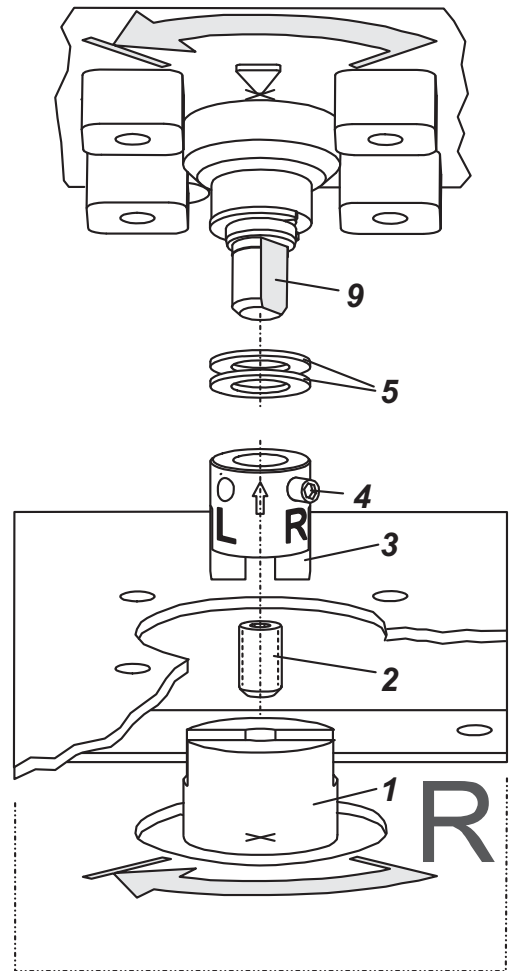
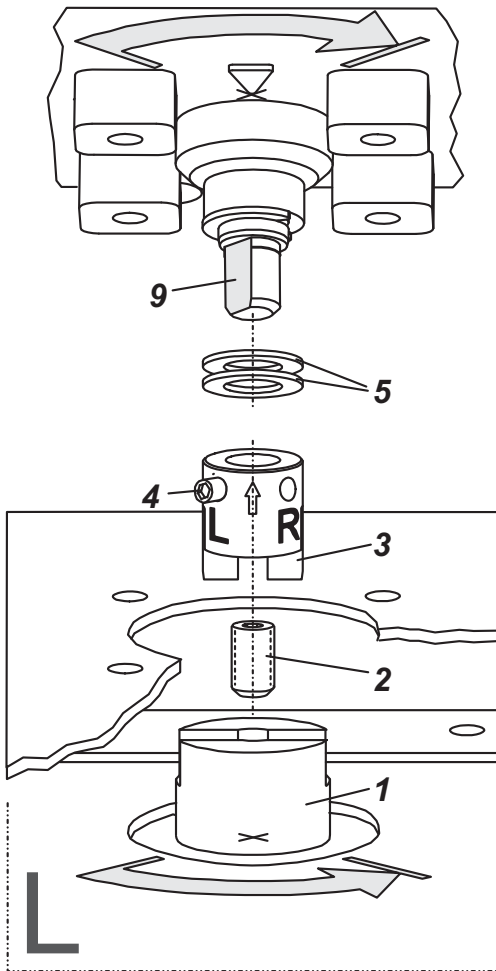

2 气动连接

气源: 1.4 to 6 bar (但不能大于执行机构的最大压力), 无油、灰尘和水!

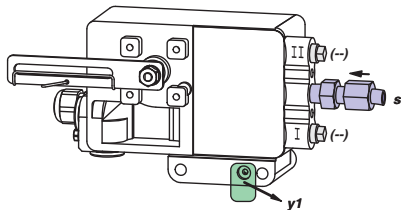

单作用, 直接安装

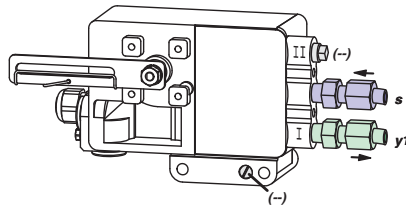

单作用

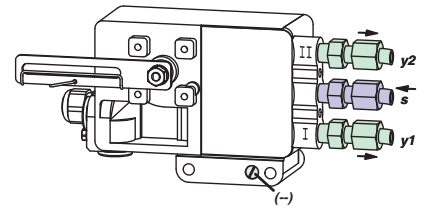

双作用

s 气源 y1, y2 气动输出 (-) 关闭

3. 电动连接

必须遵守文件 EX EVE0001 的安全要求和 SRD990 的 PSS EVE0107 文件和 MI EVE0107 文件中的要求！

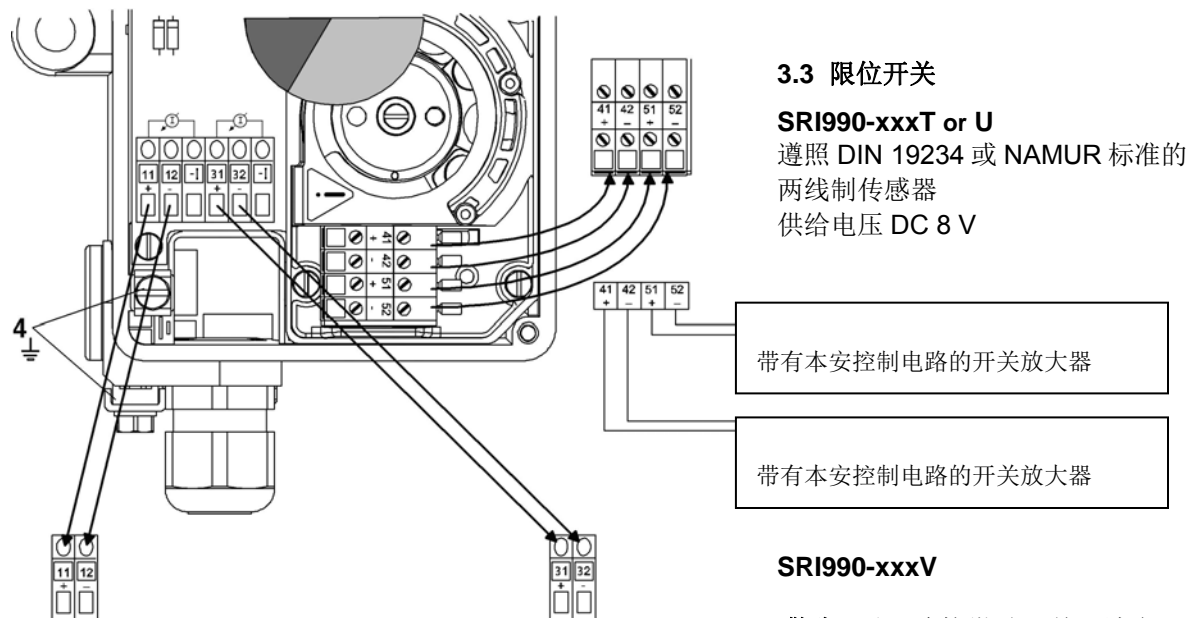

3.3 限位开关

SRI990-xxxT or U
遵照 DIN 19234 或 NAMUR 标准的
两线制传感器
供给电压 DC 8 V

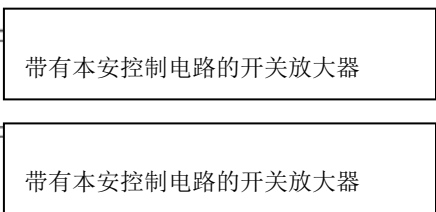

3.1 设定点

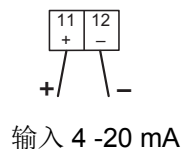

3.2 位置反馈 4-20 mA (SRI990-xxQ)

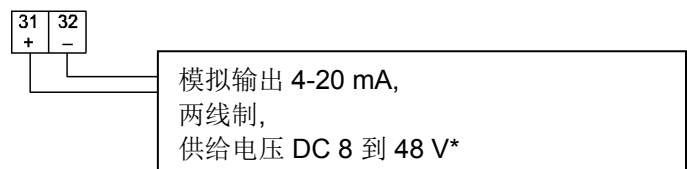

SRI990-xxxV

警告: 对于连接微动开关, 请参见主说明书并参考在文件 EX EVE0001 中所描述的安全要求。

4 启动 (通过现场开关和电位计的方式来设置)

4.1 初始设置

在定位器安装到执行机构、气源以及电输入连接完成后, 步骤如下: .
首先, 所有开关必须在位置 I。这是用于“4 to 20 mA”输入信号的设置。然后“左侧安装”(逆时针旋转)

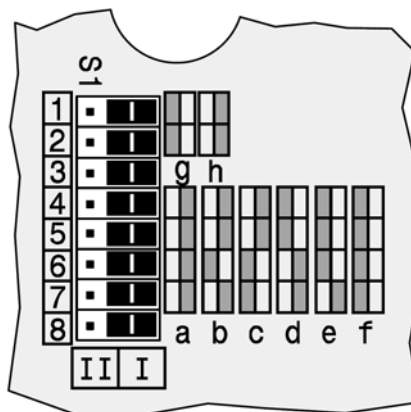

*对于本安电路, 请参照认证/最大操作电压的数据标签等等。

4.2配置反馈杆的旋转方向

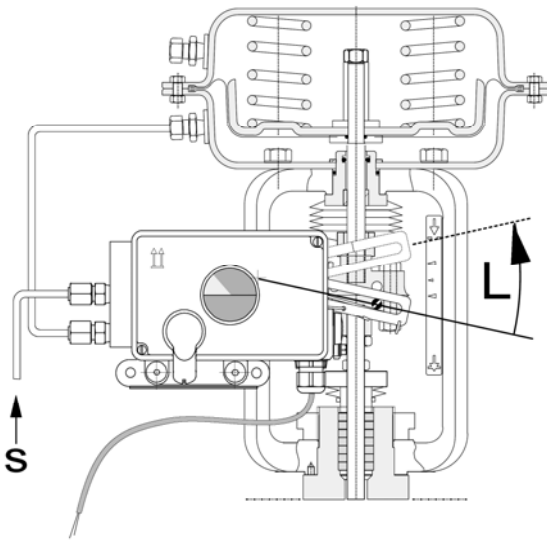

从定位器的前面看，来定义反馈杆从起点运动到终点位置的旋转方向。如有需要，转换1+2到“R”的位置。

R= 向右旋转(顺时针) L= 向左旋转(逆时针)

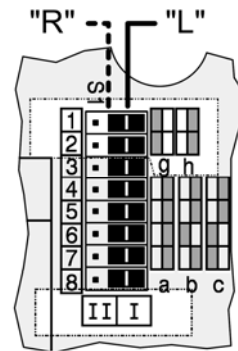

4.3设置零点、量程和增益

- 输入4 mA电信号。
- 旋拧电位计P3来调节零点(ZERO)，直到执行机构从它的底端开始运动。
向右旋拧P3：零点增大
向左旋拧P3：零点减小
- 输入20 mA电信号
- 旋拧电位计P2来调节目程(S)，直到执行机构准确的达到它的底端。
向右旋拧P2：量程增大
向左旋拧P2：量程减小
- 定位器的循环放大功能通过电位计P4来设置。调整增益以避免在连续给出输入值的时候，执行机构震颤。
- 再检查零点和量程设置。

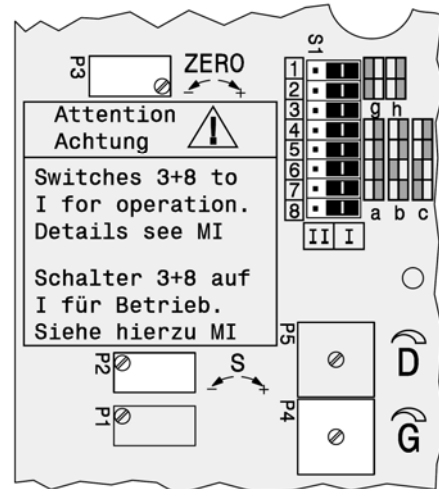

5 设置和位置变送器4-20 mA启动

必须保证位置变送器的电气连接。然后两个LED's指示灯点亮。

校准测量范围的起点(4 mA)

- 将执行机构移动到开始的位置。
- 按下 S1 “配置 4mA 输出” 按钮，时长大于 2 秒钟。此时，LED1 点亮。2 秒钟后，两个 LED's 指示灯再次点亮，4mA 的值被存储下来。

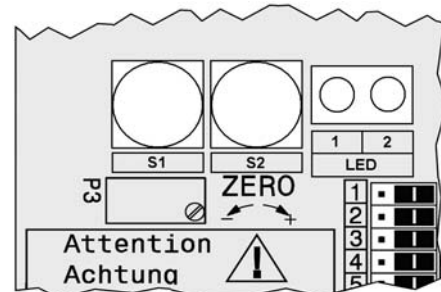

校准测量范围的终点(20 mA)

- 将执行机构移动到终点的位置。
- 按下 S2 “配置 20mA 输出” 按钮，时长大于 2 秒钟。此时，LED2 点亮。2 秒钟后，两个 LED's 指示灯再次点亮，20mA 的值被存储下来。

SRI990 Analog Positioner

These instructions are to be used as a guide for quick start-up. For more detailed information please refer to the standard documents "Master Instructions" and "Product Specification Sheet". These can be found on our Website.

1. Mounting to actuators

During operation the flat side of the spindle **9** on the back of the positioner must **always** point towards the arrow **26**. The working angle around this position is $\pm 45^\circ$

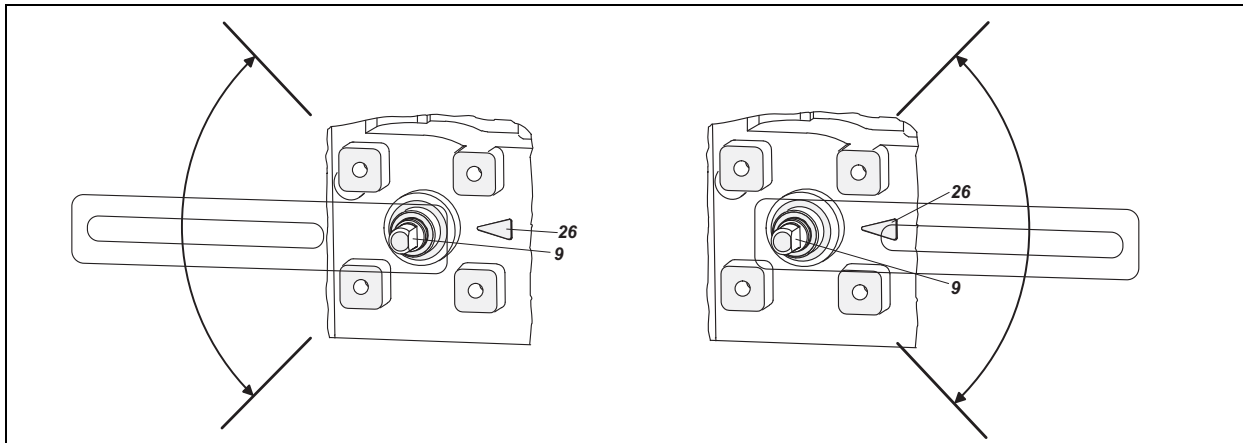

1.1 Mounting to linear actuators

NAMUR mounting
- left hand -

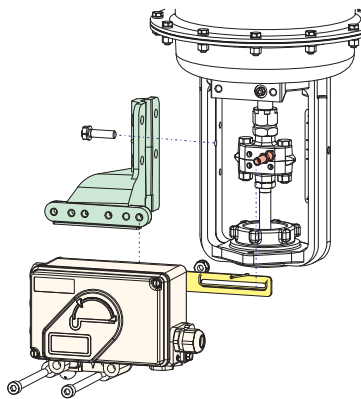

Direct mounting

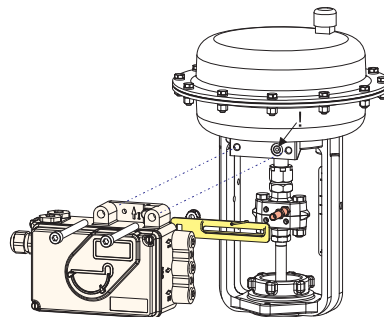

NAMUR mounting
- right hand -

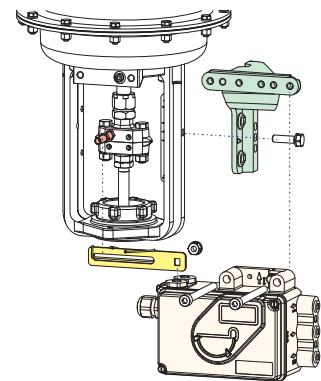

Feedback lever for linear actuators:

The carrier bolt **B** is in the slot of the feedback lever **A** and the compensating spring **F** touches the carrier bolt.

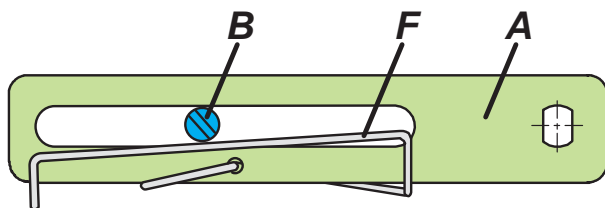

Carrier bolt B:

- 1 threaded sleeve
- 2 Stud
- 3 coupling piece

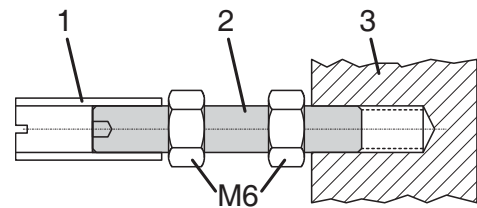

1.2 Mounting to rotary actuators

- Do not tighten grub screw **4** against the thread of spindle **9**!
- When in use the flat side of the spindle **9** must move (0 ↔ 100%) in front of the arrow **26**.
- When the product temperature rises, the drive shaft **1** increases in length. Therefore, the rotary adaptor **3** must be mounted so that approx. 1 mm (0.04 in.) of clearance results between the drive shaft **1** and the rotary adaptor **3**. This is achieved by placing an appropriate number of washers **5**, on the feedback spindle **9**, before attaching the rotary adaptor.

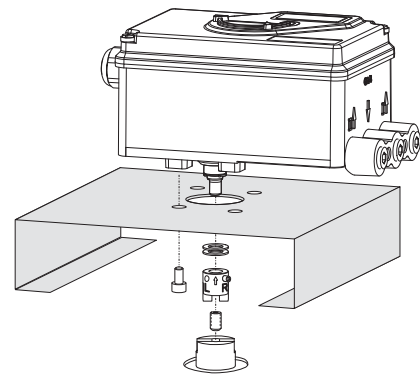

Actuator, left turning

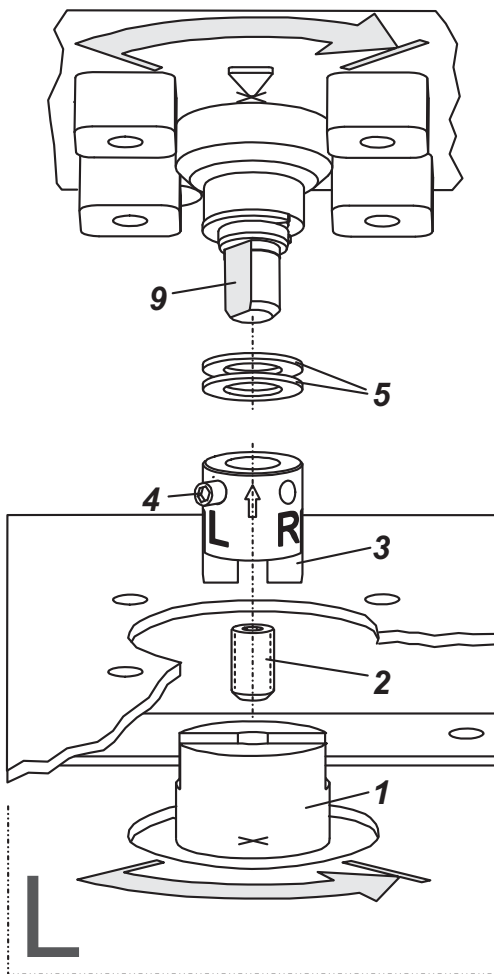

Actuator, right turning

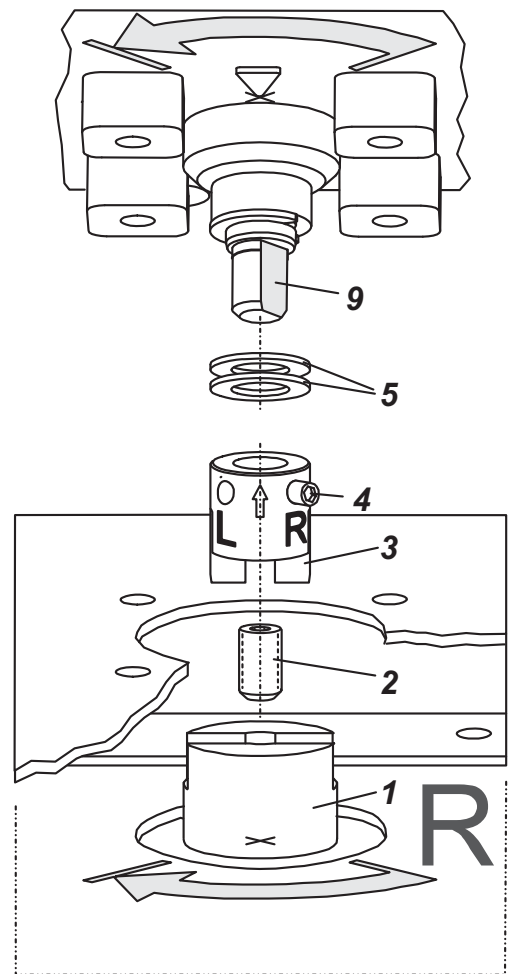

2 Pneumatic connections

Air supply (s): 1,4 to 6 bar (but not more than the max. pressure of actuator), free of oil, dust and water !

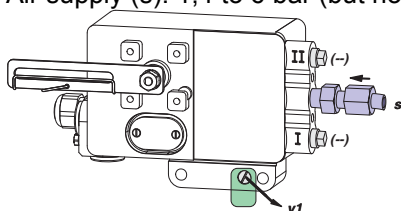

Single acting, direct mounting
s air supply y1, y2 pneumatic outputs

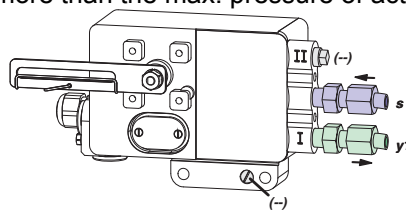

Single acting

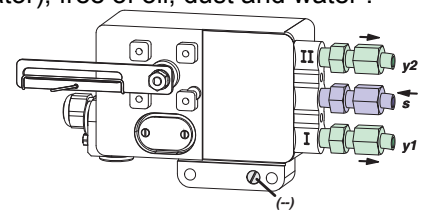

Double acting

(--) closed

3. Electrical connections

The safety requirements of document EX EVE0001 as well as the requirements of PSS EVE0107 and MI EVE0107 for SRI990 must be observed!

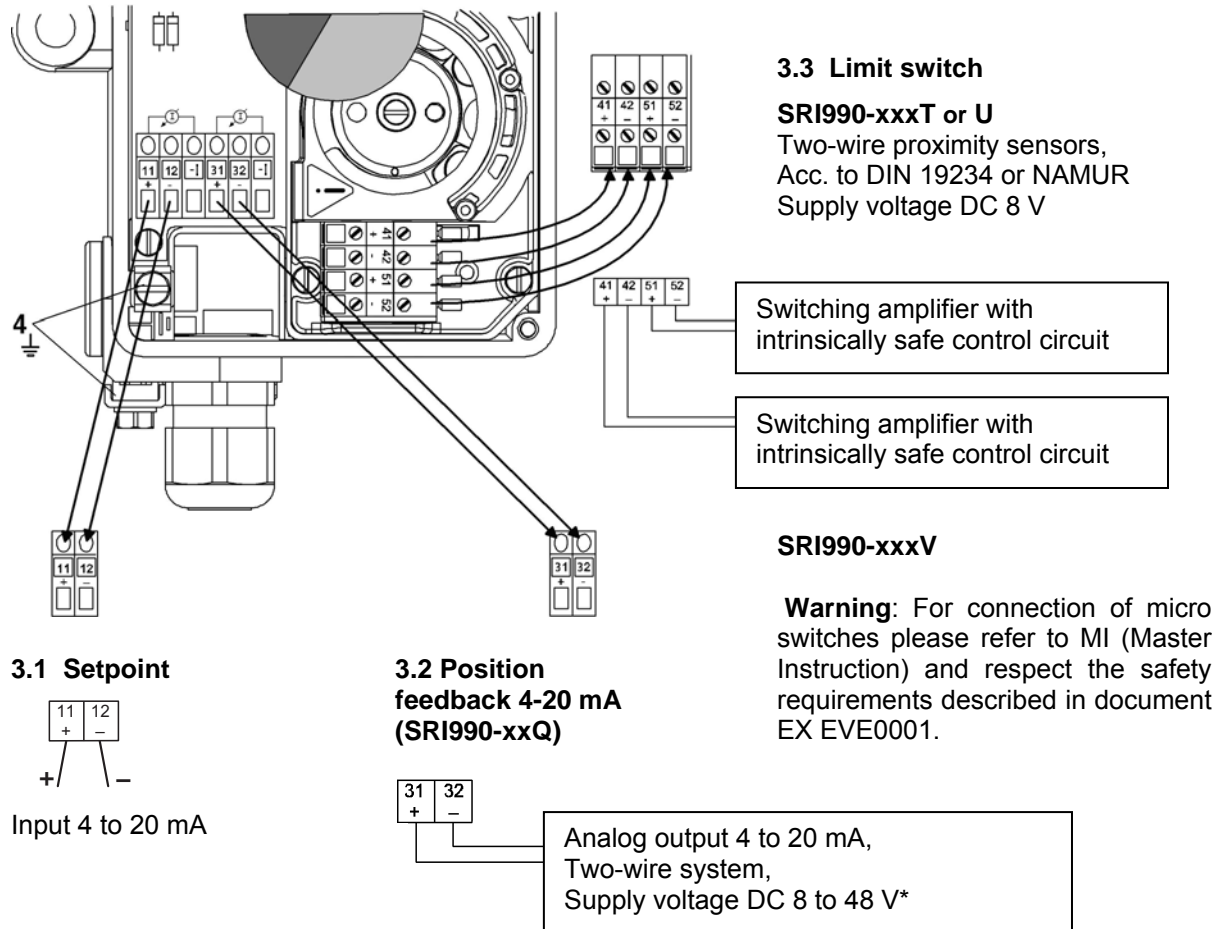

4 START UP (setting by means of local switches and potentiometers)

4.1 Initial setting

After mounting the positioner on the actuator, air and electrical input connected, proceed as follow.

First all switches must be in position I. This is the setting for Input signal "4 to 20 mA" and "Left mounted" (counter clockwise rotation).

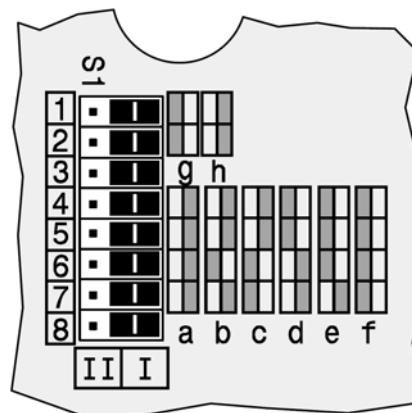

* For intrinsically safe circuits please refer to certificate / data label for max. operating voltages etc.

4.2 Configuration direction of rotation of feedback shaft

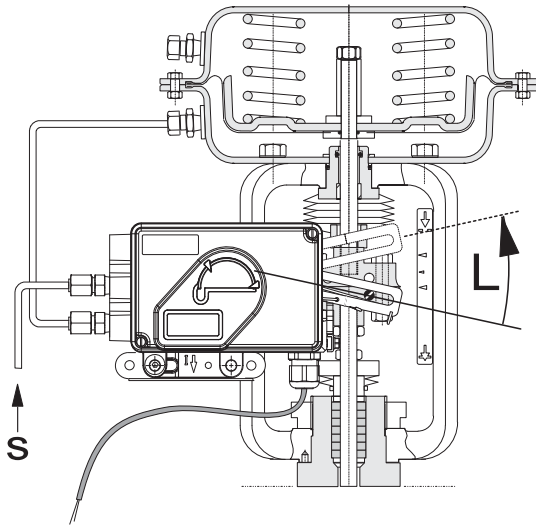

Defined as direction of rotation of feedback shaft from the start to the end position, looking at the positioner from the front. Switch 1+2 to "R" if necessary.
 R= right turn (clockwise)
 L= left turn (counter cw)

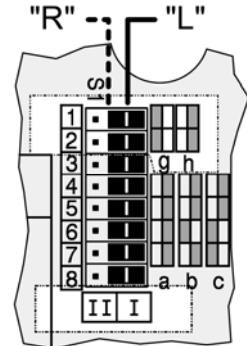

4.3 Setting of zero, span and gain

- Apply 4 mA to Input.
- Turn potentiometer P3 for zero point (ZERO) until actuator just begins to move from its end position.
 Rotation P3 to the right: zero point is increased
 Rotation P3 to the left: zero point is reduced
- Apply 20 mA to Input
- Turn potentiometer P2 for span (S) until actuator exactly reaches its end position.
 Rotation P2 to the right: span is increased
 Rotation P2 to the left: span is reduced
- The loop amplification of the positioner is set via potentiometer P4. Trim the gain so that the actuator will not swing at constant given input value.
- Re-check zero and span settings.

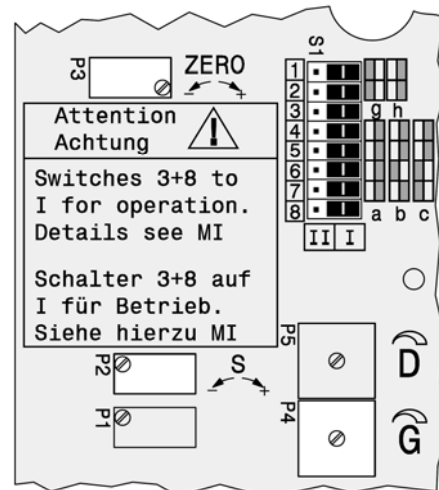

5 Setting and Start Up of position transmitter 4-20mA

The electronic connection of the position transmitter must be assured. Both LED's are then light up.

Adjusting the start of the measuring range (4mA)

- Move the actuator to the starting position.
- Press push button S1 „Config Output 4mA“ longer than 2 seconds. During this time LED 1 lights up. After 2 seconds both LED's are light up again, the value for 4mA is stored.

Adjusting the end of the measuring range (20mA)

- Move the actuator to the end position.
- Press push button S2 „Config Output 20mA“ longer than 2 seconds. During this time LED 2 lights up. After 2 seconds both LED's are light up again, the value for 20mA is stored.

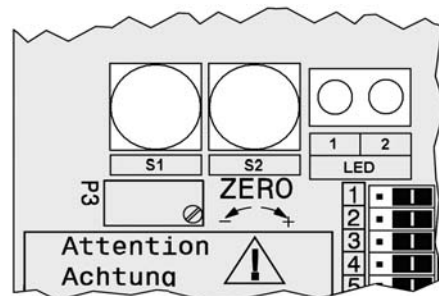

Invensys Systems, Inc.
 38 Neponset Street
 Foxboro, MA 02035
 United States of America



Global Customer Support
 Toll free: 1-866-746-6477
 Global: 1-508-549-2424
 Website:
<http://support.ips.invensys.com>

Copyright 2010-2016 Invensys Systems, Inc.
 All rights reserved.
 Invensys, Foxboro, and I/A Series are trademarks of Invensys Limited, its subsidiaries, and affiliates. All other trademarks are the property of their respective owners.

DOKT 536 022 134
 FD-QG-PO-004-EN

Life Is On

Foxboro
by Schneider Electric

Invensys Systems, Inc.
38 Neponset Street
Foxboro, MA 02035
United States of America

schneider-electric.com

Global Customer Support
Toll free: 1-866-746-6477
Global: 1-508-549-2424
Website:
<http://support.ips.invensys.com>

Copyright 2010-2016 Invensys Systems, Inc.
All rights reserved.
Invensys, Foxboro, and I/A Series are trademarks of Invensys Limited, its subsidiaries, and affiliates. All other trademarks are the property of their respective owners.

DOKT 536 022 134
FD-QG-PO-004-CH

0316