



Environmental Monitoring Unit

(Model AP9312PMI)

Service Manual

For use with APC's
Panelmount Surge
Protection Devices

Introduction

Thank you for choosing APC's Environmental Monitoring Unit (EMU) Model AP9312PMI!

This Service Manual supplements the *Environmental Monitoring Unit Management Peripheral Installation and Quick Start Guide* (part number 990-0814), *Environmental Monitoring Unit Management Peripheral User Guide* (part number 990-0815), as well as the SurgeArrest® Panelmount® Non-Modular Surge Protection Device (SPD) *Service Manual* (part number 990-0542) and *Modular SPD Service Manual* (part number 990-0541). It provides information necessary to install and maintain the EMU. This device contains no user-serviceable parts. Note: An SPD is also known as a Transient Voltage Surge Suppressor (TVSS).

Proper installation is imperative to maximize the effectiveness and overall performance of the EMU. **This device must be installed by a qualified/licensed electrician.** The electrician should follow the steps outlined in this manual to ensure proper installation. **A copy of the electrician's invoice detailing installation of this device is required in order to obtain warranty service for the device.**

The EMU performs two functions. First, it allow Facility Managers and Network Administrators remote monitoring capability of the status of APC SPD products from anywhere in the world over an Internet browser, such as Microsoft® Explorer. The EMU also provides email notification in the event of a SPD failure. When a failure occurs, a dry contact closure within the SPD signals the EMU to send up to four email messages to predetermined addresses, notifying them of an alarm condition. The email messages can be sent to computers, pagers, cell phones, and Palm® Computers anywhere in the world over the Internet.

The EMU has its own Internet Protocol (IP) address and connects through an RJ-45 network cable to an existing computer or computer network with uninterrupted access using a 10Base-T connection.

A qualified and licensed electrician is responsible for all wiring of the EMU to the network, as well as the SPD unit. A Network Administrator familiar with the installation of Internet software should perform the software portion of the installation. An optional Temperature and Humidity Probe (part number AP9512TH) is available from APC which connects to the EMU to report environmental conditions where the EMU is installed.

Note: APC products are extensively tested to industry standards as set by the IEC.

Parts List, Inspection and Safety Information

1 Parts List and Inspection

Items included in this package consists of the following:

- EMU Chassis
- 240 Volt AC to DC Power Supply
- Clip-on Ferrite Bead Inductor (with Installation Instructions)
- Two Mounting Brackets
- Four 8-32 x 3/8 Mounting Screws
- One 2-meter (6-foot) RJ-45 Network Cable (EMU to Computer)
- Software CD-ROM (includes *Environmental Monitoring Unit User Guide*)
- Warranty Registration Card
- One Terminal Block Connector
- One *EMU Service Manual* (this document)
- One *Environmental Monitoring Unit Installation and Quick Start Guide*

Carefully inspect each item for signs of damage. If damage is found, please contact APC Customer Service (1-800-800-4APC). For more information about this product or other APC products, go to www.apc.com on the internet.

2 Safety Information

This section provides pertinent safety information that must be considered before installing the EMU:

Do not install this device during a lightning storm.

- For indoor use only
- Do not install in a hot or excessively moist location.
- Other safety considerations are defined in the *Environmental Monitoring Unit Management Peripheral Installation and Quick Start Guide*, as well as the User and Service Manuals provided with the SPD unit.

WARNINGS, CAUTIONS and NOTES

- Warning statements in this manual provide information, which if not complied with, may result in personnel injury or death.
- Caution statements in this manual provide information, which if not complied with, may result in damage to equipment.
- Notes presented in this manual contain information deemed essential to highlight.

INSTALLATION and MAINTENANCE CONSIDERATIONS

The following paragraphs provide information to be considered when performing any maintenance-related task.

Fastener Installation

Installation of threaded fasteners is important. Ensure fasteners with stripped threads, corrosion, or other damage are not installed. Replace each fastener with an exact duplicate. Ensure all fasteners are installed properly. Ensure all required attaching parts such as washers, spacers, and locking devices are installed with each fastener. Ensure required torque values are applied as specified.

Electrical Bonding and Grounding

Maintaining the electrical conductivity of equipment groundpaths is important. When installation or maintenance is complete, ensure all special ground connections are restored. When installing equipment, examine the groundpath contact surfaces for defects, dirt, corrosion, or non-conductive coatings which may impede conductivity. Repair or clean contact surfaces as necessary to assure good metal-to-metal contact. Ensure fasteners are properly installed and tightened.

Wire Routing

Before removing or disturbing wires or wire bundles, note carefully the location, routing, tyrap and clamping provisions, so that wires can be installed in the same manner as found.

Electrical Connector Mating

Critical requirements in connector mating are: condition, alignment, and tightness of the connection. Before mating, wire connectors must be inspected for contamination and damage. Connector alignment and tightness must be checked and verified during every installation.

Electro-Static Discharge

The display board of the SPD uses components sensitive to the effects of electro-static discharge (ESD). Ensure service personnel are provided a continuous path to ground for the discharge of static electricity during all removal/installation procedures. The preferred grounding technique is for service personnel to wear an ESD heel strap. An alternative method is to wear an ESD wrist strap connected to a known ground point external to the device chassis.

Soldering

When soldering connections, ensure that wire leads are properly stripped of insulation material and are free of dirt or other contamination. Use flux and the proper solder type (tin-lead), as well as best soldering practices. Always verify the connection is solid by using a continuity tester.

TESTING

Any factory or on-site testing that exceeds the normal operating voltage such as high-potential insulation testing, or any other tests where the suppression components of the SPD device will be subjected to voltages higher than their rated "turn on" voltage, must be run with the SPD device disconnected from the power source. For 4-wire SPD devices, the neutral connection at the device must also be disconnected prior to performing high-potential testing, and then reconnected upon completion of the test.

Caution: Disconnect the SPD device and associated suppression components during elevated voltage testing. Failure to comply may result in damage to the suppression components and/or other electronic components (EMU).

Specifications

Nominal Input Voltage	24 Volts DC
Maximum Total Current Draw	0.1 Amp @ 24 VDC (exclusive of attached sensors)
Temperature Accuracy	±2°C (±3.6°F), from 0 to 40°C (32° to 104°F)
Humidity Accuracy	±8% RH, 10 to 90% RH, @ 25°C (77°F) ±8% RH, 30 to 80% RH, from 15 to 30°C (from 59° to 95°F)
Sensor Zone Input Response time	100 Milliseconds
Power Output	12 VDC Nominal, 60 mA Maximum Ground Referenced
Size	1.73 x 5.53 x 6.75 inches (4.39 x 14.0 x 17.3 cm)
Weight	1.8 lb. (0.8 kg)
Shipping Weight	4.6 lb. (2.1 kg)
Elevation	Operating: 0 to 10,000 ft (0 to 3,000 m) Storage: 0 to 50,000 ft (0 to 15,000 m)
Temperature	Operating: 0 to 40°C (32 to 104°F) Storage: 0 to 45°C (32 to 113°F)
Probe Operating Temperature	0 to 60°C (32 to 140°F)
Operating Humidity	0 to 95% Non-condensing
Approvals: EMC Verification	FCC, VCCI, DOC, and EN55022, Class A
Approval: Electromagnetic Immunity	EN50082-1 Verified

Life Support Policy

Information about APC's Life Support Policy is contained in the *Environmental Monitoring Unit Management Peripheral Installation and Quick Start Guide* (part number 990-0814).

3 Installation

Mounting Instructions

To install the EMU to the mounting surface, proceed as follows:

1. Attach the two supplied mounting brackets to the sides of the EMU using the four 8-32 x 3/8" Bracket Mounting Screws (provided). The flanges are to face as shown in Figure 1.

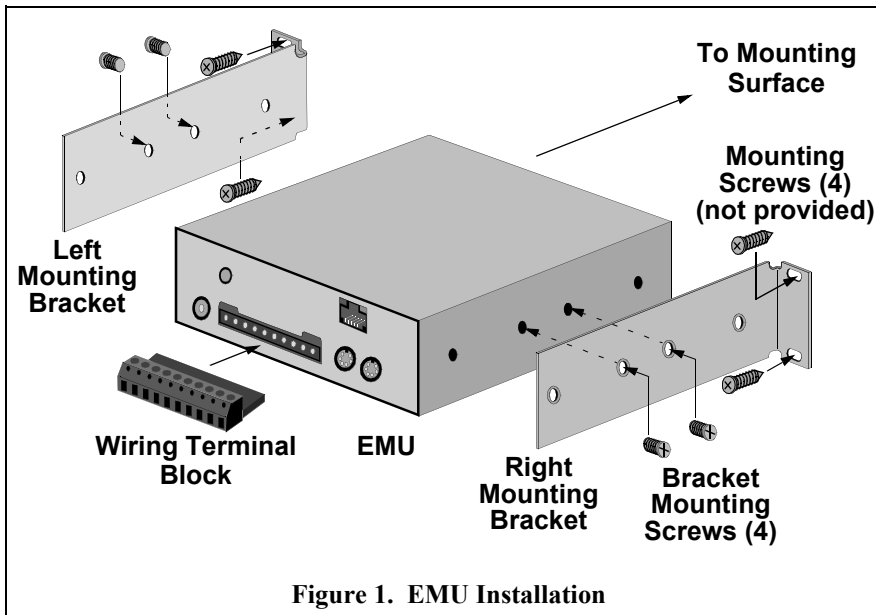

Figure 1. EMU Installation

2. Mount the EMU device in a convenient location near the SPD. Ensure the installation does not interfere with connection of the 10Base/T network cable. Consult the Network Administrator to determine what is the best location for the EMU.

Note: The distance the EMU can be mounted away from the SPD depends on the type of wire is being used and the surrounding environment. APC recommends a distance of less than 50 feet. However, if using shielded wire, a distance of about 100 feet can be attained

Wiring Instructions

To connect the Dry Contacts of the EMU to the Dry Contact of a Non-Modular or Modular SPD, proceed as follows:

1. Connect a twisted pair of 22 AWG wire to Dry Contact Pins #3 and #4 on the terminal block connector. (see Figure 2). There is no polarity requirement (see table below).

EMU Sensor Zones Connector Pinout	
Pin	Function
1	Power Supply, +12VDC nominal, 60 mA max.
2	Power Supply Ground and Normally Open Connection for all Zones
3	Zone 1 Common
4	Zone 1 Normally Closed
5	Zone 2 Common
6	Zone 2 Normally Closed
7	Zone 3 Common
8	Zone 3 Normally Closed
9	Zone 4 Common
10	Zone 4 Normally Closed

2. Drill a wire chase (hole) through the SPD enclosure (top or either side).
3. Pull the wire through the hole drilled in step 2.
4. Connect the twisted pair (from Step 1) to a pair Normally Open Dry Contacts in the SPD (see Figure 3 = Non-Modular, Figure 4 = Modular).

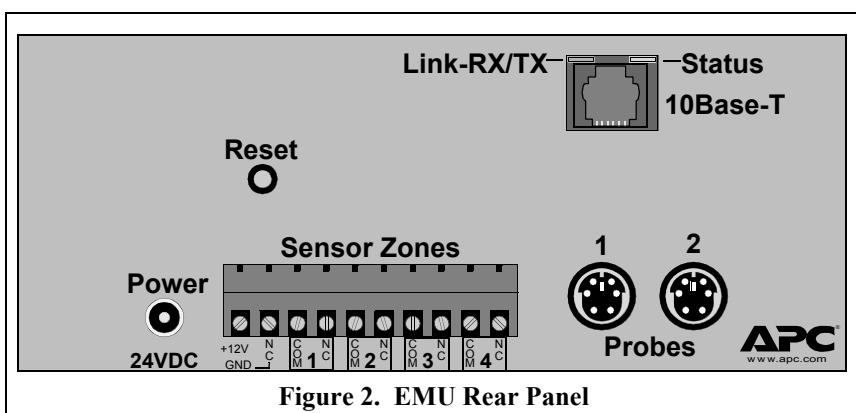

Figure 2. EMU Rear Panel

5. Connect the 240 volt Power Supply to the **Power** connector at the front panel of the EMU.
6. Connect the other end of the Power Supply to an AC power outlet.
7. Connect the Network Cable (provided) to the 10Base-T connector on the rear panel of the EMU.
8. Connect the other end of the Network Cable to the building's Network Connector.

This will make Zone 1 the monitor for the SPD product. Zones 2-4 can be used for other SPD products or other sensors types such as: Magnetic Contact Switches, Window Foil, Tamper Switches, Heat Detectors, Water Sensors, or Pressure Sensors.

9. Connect the optional Temperature and Humidity Probe (Figure 4), if purchased.
10. Apply power to the SPD.

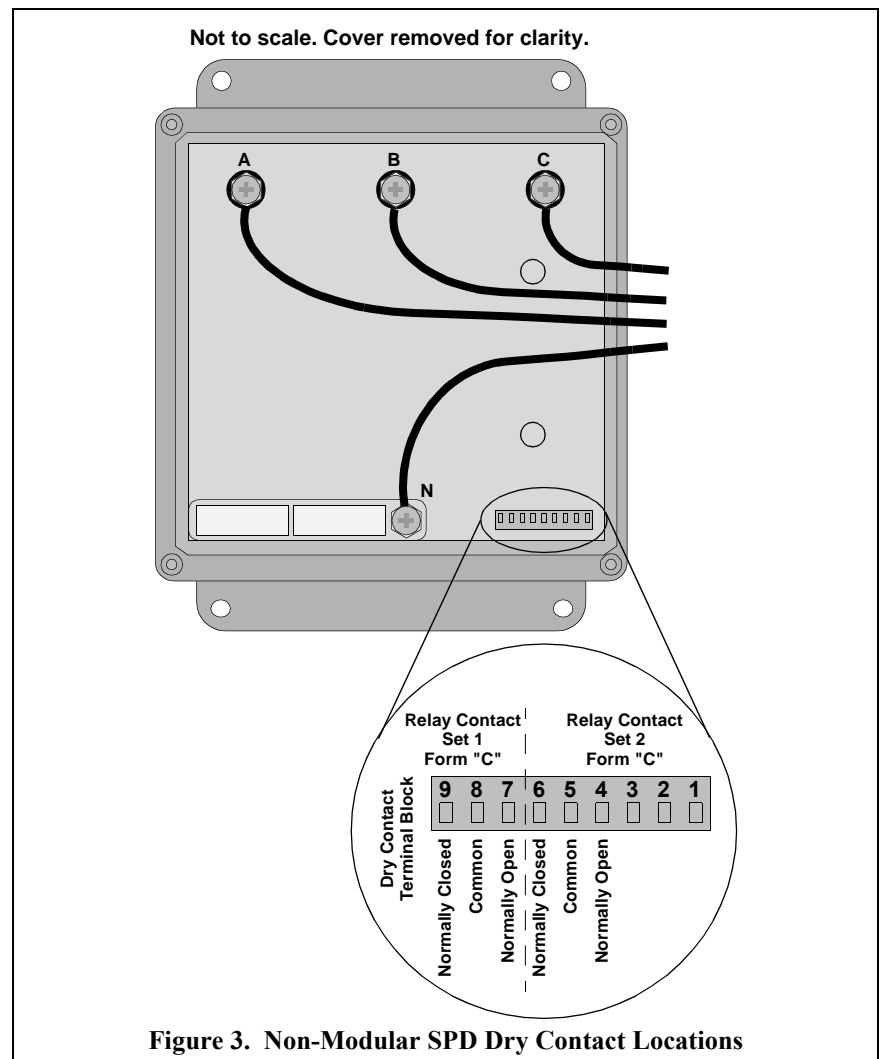

Figure 3. Non-Modular SPD Dry Contact Locations

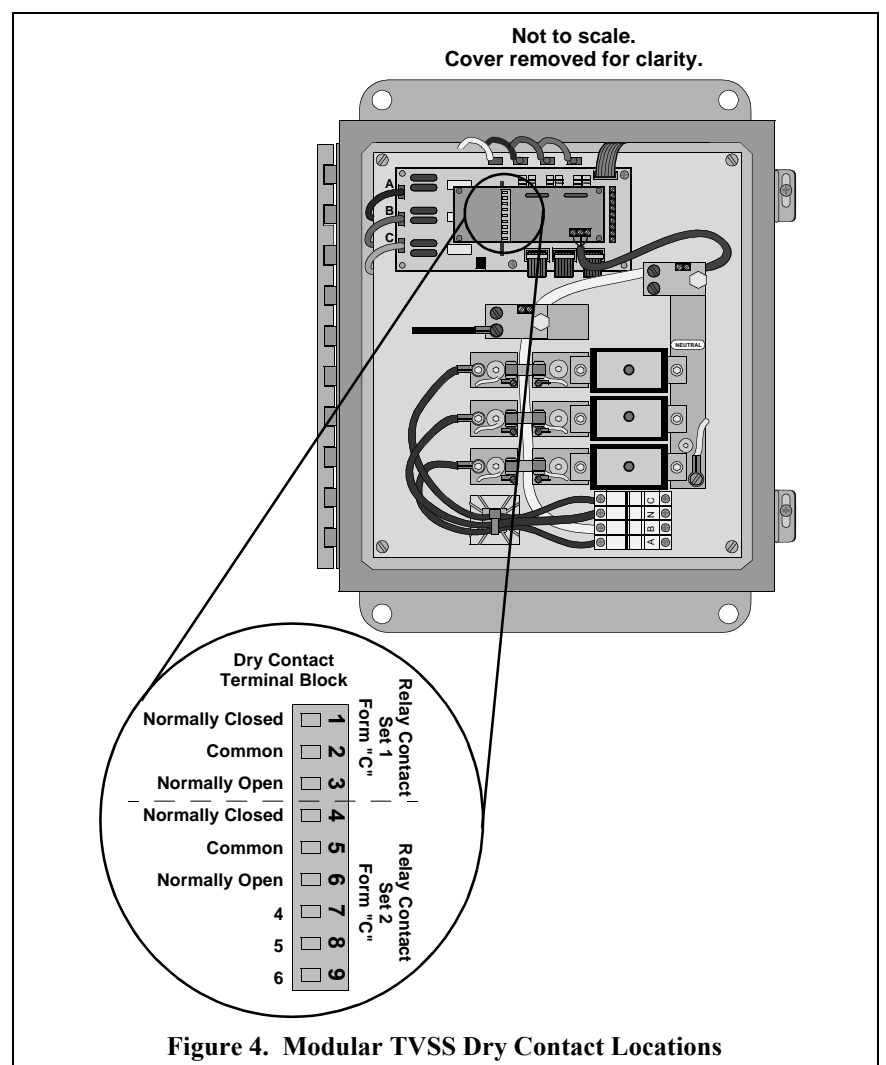

Figure 4. Modular TVSS Dry Contact Locations

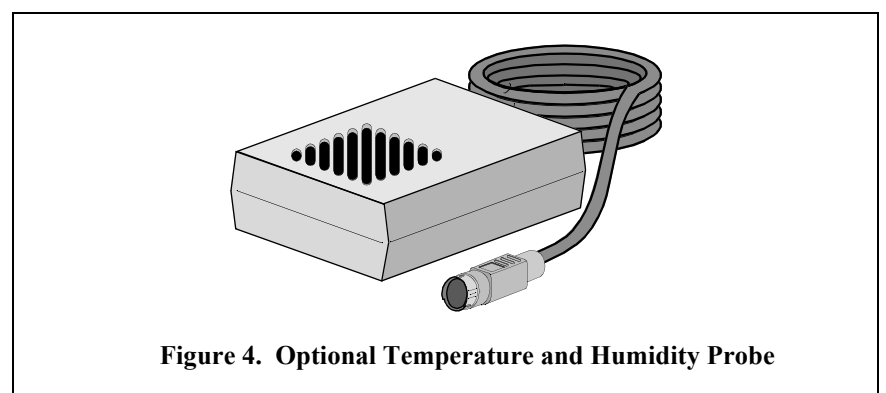

Figure 4. Optional Temperature and Humidity Probe

Additionally, the EMU provides up to 60 mA of 12 VDC at pins 1 and 2 of the Sensor Zones connector for sensors that require power (Passive Infrared (body heat) Detectors, Smoke Sensors, or Photo Relay Detectors).

Software Installation

Provide the *Environmental Monitoring Unit Management Peripheral Installation and Quick Start Guide* (part number 990-0814) and the *Environmental Monitoring Unit Management Peripheral User Guide* (part number 990-0815) that came with the EMU, to the Network Administrator. The Network Administrator must set up the software before the EMU can be used. The software installation took about 30 minutes.

To verify that the EMU is functioning properly, observe the **Link RX/TX** and **Status** indicators at top of the **10Base-T** connector. The indicators should flash whenever signalling occurs at the EMU. If the EMU does not appear to be functioning, press the Reset button on the rear panel. If that does not correct the problem, contact APC Technical Support.