

# 1 Connect Battery

The APC Home/Office Surge Protector + Battery is shipped with the battery disconnected in compliance with Department of Transportation (DOT) regulations. The unit will not operate until the battery is connected.

**NOTE:** Small sparks may occur during battery connection. This is normal.

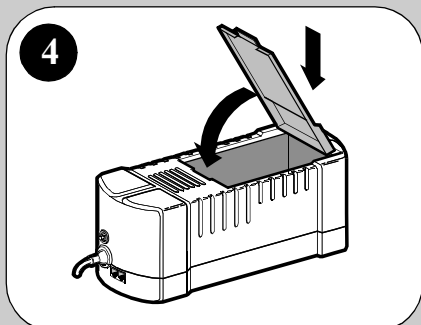
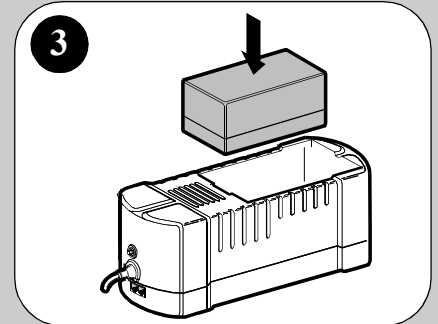
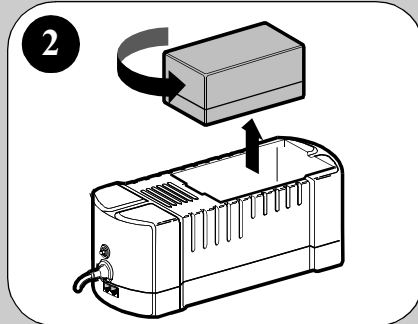
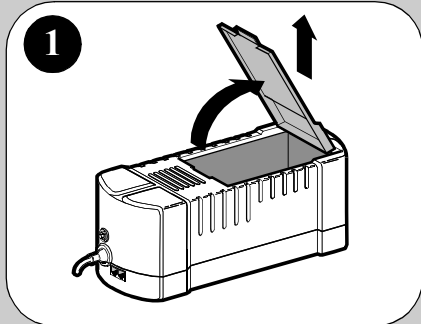

# 2 Connect Equipment

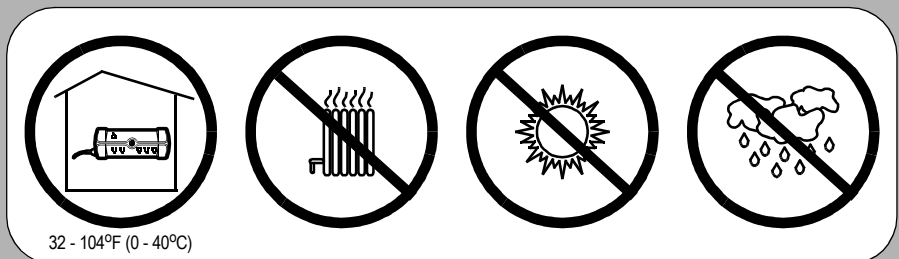

### Battery + Surge Protection

These outlets are powered whenever the unit is switched ON. During a power outage or other utility problems (brownouts, over-voltages), these outlets will be powered for a limited time by the internal battery. Plug your computer and 17" (or smaller) monitor, and one other peripheral into these outlets.

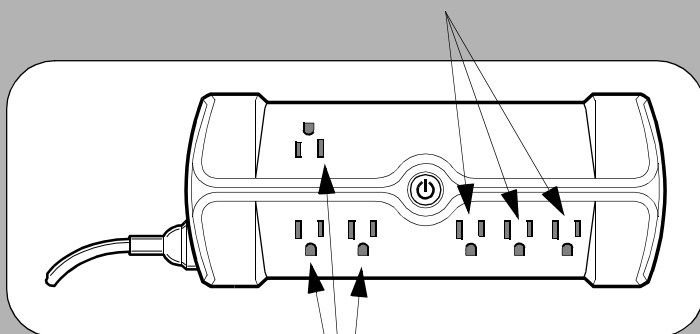

### Surge Protection Only

These outlets provide full-time protection from surges even if the unit is switched OFF. Plug your printer, fax machine, scanner, or other peripheral that does not need battery power into these outlets.

### Connect FAX/Modem/Phone

The unit protects a single line (2-wire) fax, modem or phone from surges when it is connected as shown below.

### Connect AC Line Cord

Connect the AC line cord to a 120-volt outlet.

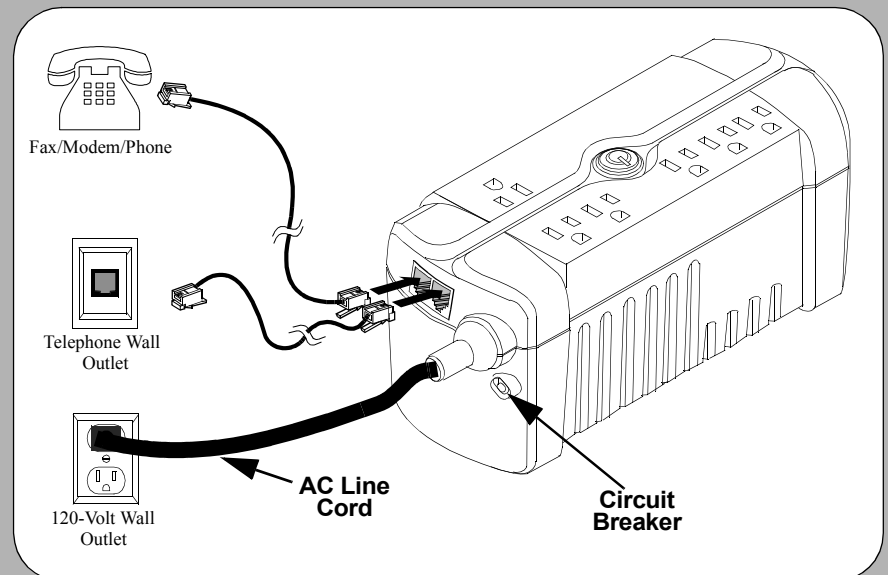

## Status Indications

The Home/Office Surge Protector + Battery provides status indications through the flashing of the "Power On" indicator, as well as audible beeps. The indications are as follows:

Status	Visual Indications	Audible Indication	Alarm Terminates When
<b>On Line</b> - Unit is supplying conditioned utility power to your equipment	Power On LED - ON	None	n/a
<b>On Battery</b> - Unit is supplying battery power to the equipment connected to the battery powered outlets	Power On LED - ON (off during beep)	Beeping 4 times every 30 seconds	Unit returns to an On Line status or when the unit is turned off.
<b>Low Battery Warning</b> - Unit is supplying battery power and the battery is nearly depleted. Once depleted, the unit will turn off.	Power On LED - Flashing	Rapid beeping (one second intervals)	Unit is turned OFF, returns to On Line or when the battery is finally exhausted and the unit turns off.
<b>Replace Battery</b> - Battery may need to be replaced, or the battery is not connected.	Power On LED - Flashing	Continuous tone.	Unit is turned OFF and then ON and it passes a subsequent battery test. (This test occurs automatically whenever the unit is turned ON and every 14 days)
<b>Overload Shutdown</b> - During On Battery operation a battery-power outlet was overloaded.	Power On LED - OFF	Continuous tone.	Unit is turned off using the ON/OFF button.

# 3 Power On

The Home/Office Surge Protector + Battery should be allowed to charge for at least 16 hours to ensure sufficient runtime. The unit is being charged whenever it is connected to utility power, and the unit is turned ON.

Power ON the unit by pressing the ON/OFF button. Turn on your equipment.

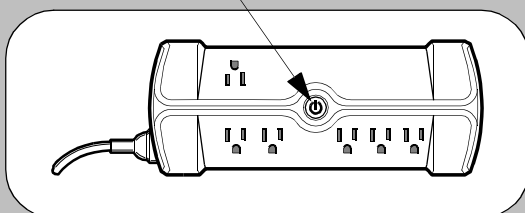

**Note:** The on/off switch is illuminated when in the ON position. The switch may flash to indicate changing power conditions (see *Status Indications*).

# Troubleshooting

Consult APC Online Technical Support or call APC Technical Support for assistance with problems that cannot be resolved using the table below:

Problem	Probable Cause	Solution
Unit will not turn on.	Battery is disconnected. Circuit Breaker has tripped.  Utility power not available at the wall outlet.	Connect the battery (see <i>Connect Battery</i> ). Reduce the amount of equipment plugged into the "Battery Backup + Surge Protection" outlets. Reset the Circuit Breaker by pushing it back in.  Reduce the amount of equipment plugged into the "Surge Protection" outlets. Reset the Circuit Breaker by pushing it back in.  Ensure that the fuse or circuit breaker for the outlet is okay, and that the wall switch controlling the outlet (if any) is in the ON position.
Connected equipment loses power.	Equipment is connected to the "Surge Protection" outlets.  The unit is overloaded.  The unit has exhausted its available battery power.  Connected equipment does not accept the step-approximated sine waveform the unit.  The unit may require service.	Ensure that the equipment you want to stay powered during a power failure is plugged into the "Battery Backup + Surge Protection" outlets and NOT the "Surge Protection" outlets.  Make sure that the equipment plugged into the outlets of the unit are not overloading the capacity of the unit. Try removing some of the equipment and see if the problem continues.  The unit can only operate on battery power for a limited amount of time. The unit will eventually turn off when the available battery power has been used. Allow the unit to recharge for 16 hours before continuing use of the unit.  The output waveform is designed for computers and computer-related equipment. It is not designed for use with motor-type equipment.  Contact APC Technical Support for further troubleshooting.
The power On button is lit and the unit is beeping four times every 30 seconds.	The unit is using battery.	The unit is operating normally and using battery power. Once On Battery, you should save your current work, power down your equipment, and turn the unit OFF. Once normal power is restored, you may turn the unit back ON and power your equipment.
The power On button flashes once per second and the unit beeps once per second at the same time.	Battery capacity is low (about 2 minutes of use remaining).	The unit is about to shut off due to a low battery charge condition! When the unit beeps once every second, the battery has about 2 minutes of power remaining. Immediately power down your computer and turn the unit OFF. When normal power returns, the unit will recharge the battery.
Inadequate runtime.	The battery is not fully charged.  Battery is near the end of useful life.	Allow the unit to charge by leaving it plugged into the wall a full 16 hours. As a battery ages, the amount of runtime available will decrease. You can replace the battery by ordering one at <a href="http://www.apc.com">www.apc.com</a> . Batteries also age prematurely if the unit is placed near excessive heat.

## Specifications

Item	Specification
Voltage	120 Vac Nominal
Acceptable Input Frequency	57 - 63 Hz
Low-Voltage Transfer Point (when unit starts operating on battery)	88 Vrms
High-Voltage Transfer Point	141 Vrms
Battery Back-up Capacity (3 outlets)	325 VA/185 W
Surge Protection Capacity (6 outlets)	15 Amps (includes battery-powered outlets)
Voltage (on battery power)	115 Vrms $\pm$ 8%
Frequency (on battery power)	60 Hz $\pm$ 1 Hz
Transfer Time to Battery	5 ms typical
AC Surge Protection	Full time, 1800 eP Joules (battery-powered outlet)
Telephone Line Surge Protection	Single line (2-wire) analog (RJ-11C)
EMI/RFI Filter	Full time
Input Overload Protection	Resettable circuit breaker (15A)
Battery Type	Sealed, maintenance-free lead acid
Recharge Time	8 to 16 hours typical from total discharge
Average Life	2 - 4 years depending on the number of discharge cycles and environmental conditions
Net Weight	8.13 lb (3.69 kg)
Size	4.64"H x 3.74"W x 10"D (118mm x 95mm x 254mm)
Operating Temperature	32 - 104° F (0 - 40° C)
Storage Temperature	-15 to 45° C
Operating Relative Humidity	Operating Relative Humidity: 0 - 95%
Operating Elevation	0 - 10,000 ft (0 to 3000m)
Safety Approvals	UL 1778 listed, cUL certified per CSA standard C22.2 No. 107.1
EMC Compliance	FCC part 68, FCC part 15 Class B Notice: This equipment complies with Part 68 of the FCC rules and the requirements adopted by the ACTA. Operation is subject to the following two conditions: (1) This device may not cause harmful interference, and (2) This device must accept any interference received, including interference that may cause undesired operation. Additionally, on the bottom of this equipment is a label that contains, among other information, a product identifier in the format US:AAAEQ##TXXXX. If requested, this number must be provided to the telephone company.

## Order Replacement Battery

Replace with an APC qualified battery. Replacement batteries can be ordered from [www.apc.com](http://www.apc.com) or by calling APC Technical Support (valid credit card required). Have your unit model number available when ordering. Your model number can be found on the bottom of the unit.

## Warranty

The standard warranty is 2 years from the date of purchase. APC's standard procedure is to replace the original unit with a factory reconditioned unit. Customers who must have the original unit back due to assigned asset tags and set depreciation schedules must declare such a need at first contact with APC Technical Support. APC will ship the replacement unit once the defective unit is received by the repair department or cross-ship upon the provision of a valid credit card number. The customer pays for shipping to APC, and APC pays ground freight transportation costs back to the customer.

## Contact Information

Internet	<a href="http://www.apc.com">http://www.apc.com</a>
Email	<a href="http://www.apc.com/support">http://www.apc.com/support</a>
USA/Canada	800.800-4272
Worldwide	+1.401.789.5735
American Power Conversion	32 Fairgrounds Road West Kingston, RI 02892

## Safety

This section contains important instructions that should be followed during installation and maintenance of the APC equipment and batteries. It is intended for APC customers who setup, install, relocate, or maintain APC equipment.

This equipment is intended for installation in a temperature-controlled indoor area (see **Specifications** for exact temperature range), free of conductive contaminants.



### Electrical Safety

To reduce the risk of fire, connect only to a circuit provided with 20-amp maximum branch circuit overcurrent protection in accordance with the National Electrical Code ANSI/NFPA.



### CAUTION! De-energizing Safety

The unit has an internal energy source (the battery); the output may be energized when the unit is not connected to an AC power outlet.

To de-energize pluggable equipment: switch the unit off. Disconnect the unit from utility power. Next, disconnect the equipment from the unit. Disconnect the internal battery (see **Connect Battery**).

(of consequence)The unit includes a protective earth conductor which carries the leakage current from the load devices (computer equipment). Total leakage current must not exceed 3.5 mA.

(of consequence)Use of the unit in life support applications where failure of the unit can reasonably be expected to cause the failure of the life support equipment or to significantly effect its safety or effectiveness is not recommended.



### WARNING! Battery Safety

- Except for the battery, this unit contains no user-serviceable parts. This equipment contains potentially hazardous voltages. Do not attempt to disassemble the unit. Repairs are performed only by factory trained service personnel.



**Batteries must be recycled.** Deliver the battery to an appropriate recycling facility or ship it to the supplier in the new battery's packing material. See the new battery instructions for more information.

- Do not dispose of batteries in a fire. The batteries may explode.
- Do not open or mutilate batteries. They contain an electrolyte which is toxic and harmful to the skin and eyes.
- To avoid personal injury due to energy hazard, remove wrist watches and jewelry such as rings when replacing the batteries. Use tools with insulated handles.
- Replace batteries with the same part number and type as originally installed in the unit.

### Replacement and Recycling of Batteries

- See your dealer for information on replacement battery kits and battery recycling.

## Service

Please DO NOT RETURN the unit to the place of purchase under any circumstances.

- Consult the Troubleshooting section to eliminate common problems.
- Verify the battery is connected (see *Connect Battery*) and that the Circuit Breaker is not tripped (see *Troubleshooting* section).

If you still have problems or questions, please contact APC via the internet or at one of the phone numbers listed below.

- Before contacting APC, please be sure to record the date purchased, model and serial number (on bottom of unit).
- Be prepared to troubleshoot the problem over the telephone with a Technical Support Representative. If this is not successful, the representative will issue a Return Material Authorization Number (RMA#) and a shipping address.

Pack the unit in its original packaging. If the original packaging is not available, ask APC Technical Support about obtaining a new set. Pack the unit properly to avoid damage in transit. Never use foam beads for packaging. Damage sustained in transit is not covered under the warranty (insuring the package for full value is recommended).

- Write the RMA# on the outside of the package.
- Return the unit by insured carrier to the address given to you by APC Technical Support.