

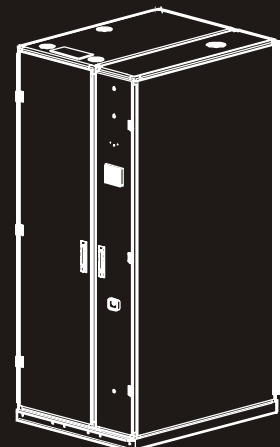

High-Density Cooling Enclosure

ARAC15000U
ARAC15000T

Operation and Maintenance



Contents

Operation	1
Display Interface	1
Using the Display	2
Passcode entry	2
Main menu screen	2
Navigate the interface	3
HDCE security	4
Start the unit	5
Settings	6
Display Interface Parameters List	8
Basic parameters	8
Advanced parameters	10
View Status Readings	14
Status menu	14
Readings	14
Calculations	14
Temperature reading overview	15
Set Up Alarms	16
Respond to Alarms	17
Alarms on HDCE display interface	17
Access alarms	17
Alarm messages and suggested actions	18
Alarm log parameters	24
Clear alarms	26
Actual alarms	26
Set Up the Display	27
Date and time	27

Remote Monitoring Unit for HDCE 29

Operation 29
Remote Monitoring Unit alarms 29

Maintenance 31

Replacing Components 31

Fan assemblies 31
Cooling coil cartridge filter 32

Monthly Preventive Maintenance 33

Environment 33
Mechanical 34
Electrical 34
Functional tests 34
Final inspection 35

Quarterly Preventive Maintenance 36

Mechanical 36
Electrical 36
Functional tests 36

Semi-Annual Preventive Maintenance 37

Cleanliness 37
Mechanical 37
Electrical 37
Functional tests 37

Warranty 39

Warranty Statement 39

APC product covered 39
Terms of warranty 39
Non-transferable Warranty extends to first purchaser for use . 39
Assignment of warranties 40
Drawings, descriptions 40
Warranty claims procedure 40
Exclusions 41

Operation

Display Interface

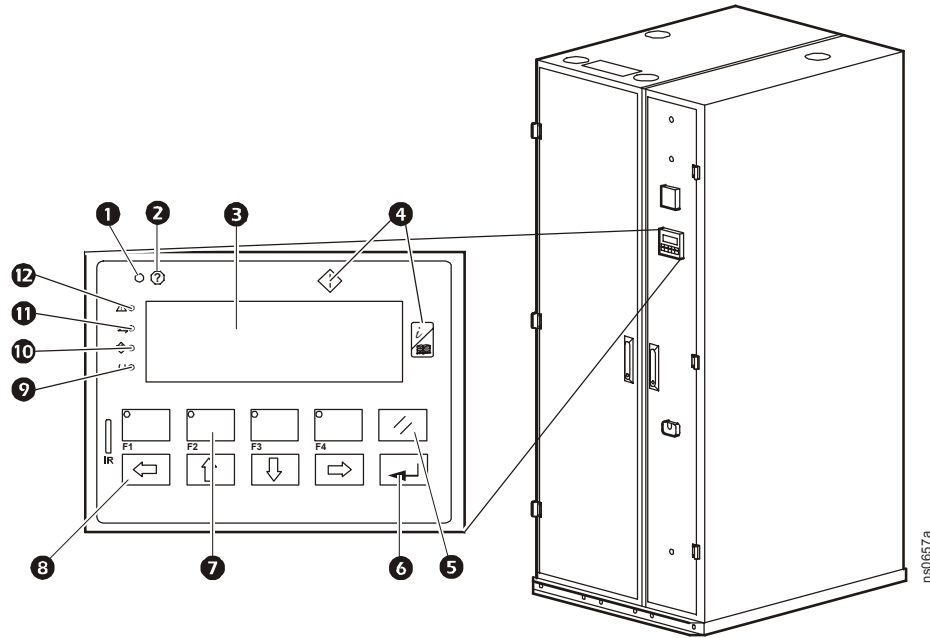

Item	Function
❶ Key pressed LED	LED light notifying user when button is pushed.
❷ Firmware access key	Displays the firmware version of the Program Logic Controller (PLC) software and system firmware.
❸ Liquid Crystal Display (LCD)	View alarms, status data, instructional help, and configuration items.
❹ Inactive keys	Keys do not function at this time.
❺ Edit key	Press to edit settings.
❻ Enter/confirmation key	Select settings and input changes to unit's settings.
❼ Function keys	Use to select menu items from the interface. Keys F1, F2, F3, and F4 match corresponding menu items on the interface.
❽ Navigation arrow keys	Select menu items and access information.
❾ Power LED	Indicates power is being drawn to the display.
❿ Non-functional LED	LED does not function at this time.
⓫ Communication LED	Indicates communication between the display and the PLC or between the display and an external source.
⓬ Alarm LED	Indicates alarm has occurred.

Using the Display

Upon start-up, the HDCE runs a self-test and displays the version of the firmware. After several seconds the HDCE will start-up on a welcome screen. Scroll down using the Down navigational arrow key to see the display panel firmware and the PLC firmware.



Passcode entry

From the welcome screen, enter the passcode to access the main menu. The factory default passcode is **0004**. To enter this passcode:

1. Scroll to the top of the welcome screen using the Up navigational arrow key.
2. Press the EDIT key to edit the numbers and characters for the passcode.
3. Use the navigational arrow keys “Up” and “Down” to select the default passcode.
4. Press the ENTER key once the passcode is entered and proceed to the main menu.

Main menu screen

After entering the passcode on the welcome screen, the main screen displays and allows you to access the menu items with which to navigate the interface and view and edit the unit’s settings.

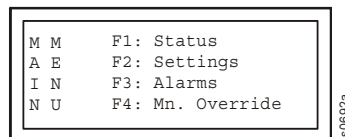

Navigate the interface

Function keys. The function keys allow you to select menu items as you navigate the interface. To select a menu item, press the corresponding function key that is listed next to the menu item **1**. After pressing the corresponding key the interface will display the menu selected **2**.

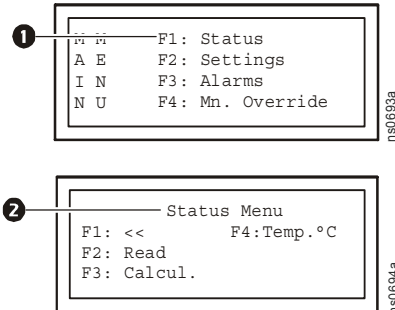

Arrow keys. The up, down, left, and right arrow keys allow navigation of the screen displayed on the interface. Use the up and down arrows to scroll through screens that have several settings. The navigational arrows can also be used to move horizontally to settings on the screen and to move the cursor when in edit mode.

Edit key. The EDIT key on the display interface is used to edit settings displayed on the interface. Press the EDIT key to enter edit mode and modify information on the display. A blinking cursor will appear on the display when the EDIT key has been pushed.

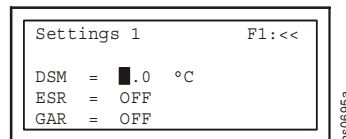

Navigate the interface with the cursor and place the cursor on a setting **1** you would like to modify. Pressing the EDIT key will then allow you to change that setting using the navigational arrows to scroll through different characters or to select an available option **2** for that setting.

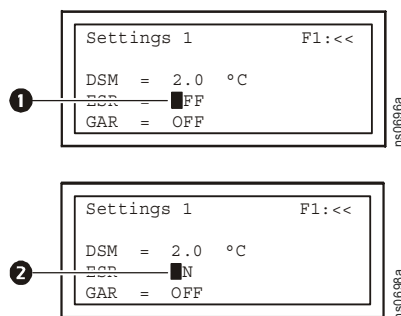

Note

Press the ENTER key to confirm the change of a setting when finished.

Cursor. The cursor becomes active after pushing the EDIT key. The cursor is displayed as an underscore underneath the number or character the cursor is on. The cursor may be difficult to view in some of the settings screens with numerous settings to edit. To display the cursor again press the EDIT key.



The cursor will disable the “Return to main menu” screen function until the setting the cursor is currently selecting is completed by pressing the ENTER key to confirm the change of the setting.

HDCE security

Access levels. The unit has three access levels that are available with three different access cards:

- **Rack Equipment Unit (REU) access** - for users who need access to the rack enclosure; allows users to access both the front and rear of the rack enclosure.
- **Equipment Cooling Unit (ECU) access** - for users who need access to the cooling enclosure; allows users to access both the front and rear of the cooling enclosure.
- **REU/ECU access** - for users who need access to the rack and cooling enclosures; allows users to access all doors of both the rack and cooling enclosures.

Access card code layout.

The access card code layout definition is:

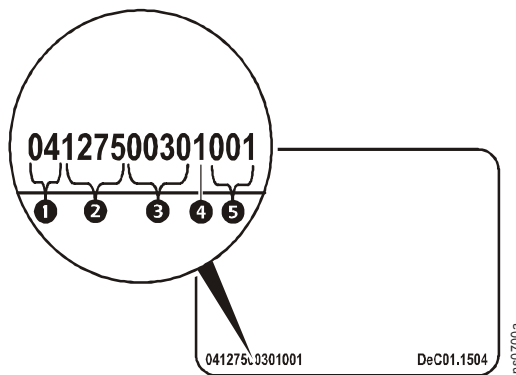

- YY=Year of ordering ❶
- 0000=Manufacturing ordering number ❷
- PPPP=Manufacturing position number ❸
- A=Type of access: 0 for ECU access only/1 for REU access only/2 for both ECU and REU access ❹
- RRR=Client serial number ❺

In total, 64 different entry codes can be programmed in the PLC. If an invalid access card code is used, an alarm will be generated. The last 10 access card codes used (valid and invalid) are stored in the respective interface registers together with time and date of incidence.

Card reader indicator LEDs. Three indicator LEDs signal the status of the unit when lit:

- The **red** indicator LED **1** remains on when all magnetic locks are closed and flashes if all doors are open.
- The **green** indicator LED **2** remains on when all of the following conditions are active:
 - The supply air temperature in the cabinet is higher than room dew point, added with the safety margin (DSM), of the air entering the unit when the doors are opened.
 - There is no signal of “gas gone” from the FPU fire extinguishing unit.
- The **green** indicator LED **2** flashes when the supply air temperature in the cabinet is being adjusted to prevent condensation of moisture from the air entering the unit when the doors are opened.
- The **yellow** indicator LED **3** remains on when the card reader is on.

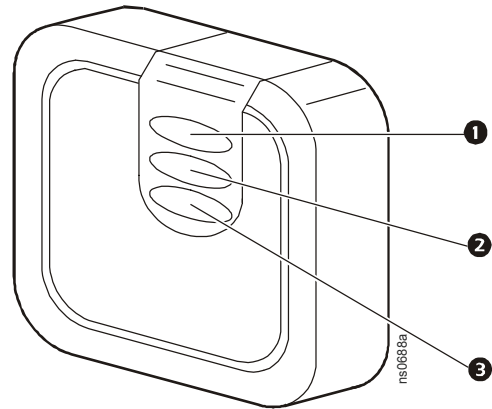

Note

The flashing rate of the LED will depend on the difference between average supply air temperature and temporarily increased set-point.



Note

The unit will automatically lock after a time delay of 10 seconds.

Start the unit

Upon start-up, the unit will run on a soft-start. The soft-start feature is built in to avoid possible condensation problems when the heat exchanger is first commissioned or when any of the doors have been opened once the unit is operating. Swipe the ECU/REU access card to begin soft start.



Note

Fans will power on and will switch randomly to test if there is equipment within the unit to produce resistance to airflow. If equipment is not present, blanking panels can be used to create resistance to airflow and therefore avoid any pressure related alarms.

Settings

The Settings menu is the only menu that is editable from the display interface. The other main menu options, Status and Alarms, are read-only screens. Access the Settings menu from the main menu screen by pressing F2.

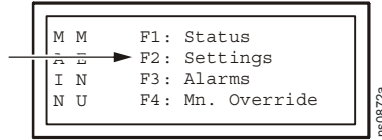

From the Settings 1 screen, navigate through the interface using the navigational arrows and the EDIT key to view different settings and adjust them if necessary.

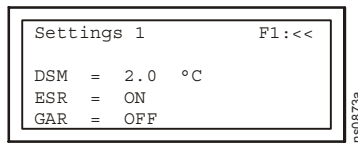

Manual override code. Alternatively to the access cards, a manual override code may be used to access the HDCE. To enter the manual override code:

1. From the main menu press F4 to go to the manual override code menu.

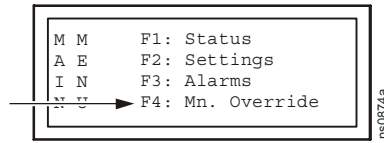

2. Press F2 to enter the manual override code screen.

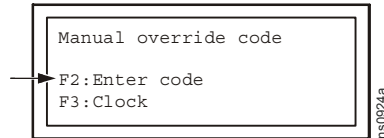

3. Press F2 to enter the manual override code.

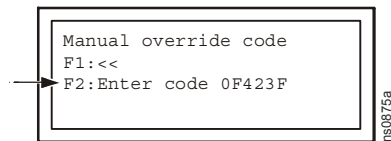

4. After pressing F2, use the up and down navigation arrow keys to enter the override code.

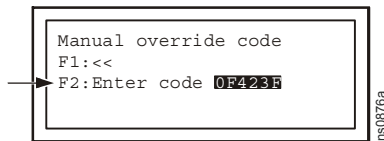

5. Press the left and right navigation arrow keys to change the position of the cursor.
6. Press the ENTER key to activate the entered code. If the code is correct, the accessible doors are released.

Display Interface Parameters List

The HDCE control parameters are divided in two main groups: basic and advanced parameters. The basic parameters are adjustable for the end user via the HDCE local cabinet from the local display panel and via the local PLC RS485 port. Advanced parameters are only accessible for trained service personnel via a direct communication link between the PLC and a laptop or PC on which special servicing software is installed.

For the identification of the HDCE control parameters, three character abbreviations are used. In the table below the basic parameters (adjustable via the local display) are listed in alphabetic order:

Basic parameters

Settings Menu.

Parameter	Description	Menu	Unit
DSM	Dew point Safety Margin	Settings 1	[C°]
ESR	External SDU Reset	Settings 1	[0=false, 1=true]
GAR	General Alarm Reset	Settings 1	[0=false, 1=true]
ITD	Initialization Time Delay	Settings 1	[hours]
LTD	Leakage Time Delay	Settings 1	[min]
MGR	Manual Gas Release	Settings 1	[0=false, 1=true]
MTD	Maglocks Time Delay	Settings 1	[min]
PDS	Pressure Differential Setpoint	Settings 1	[Pa]
RAL	Return Air temperature alarm Level	Settings 1	[C°]
RTS	Return air Temperature Setpoint	Settings 1	[C°]
SDT	Slope Down supply air Temperature	Settings 1	[C°/min]
STS	Supply air Temperature Setpoint	Settings 1	[C°]
SUT	Slope Up supply air Temperature	Settings 1	[C°/min]

Readings.

Parameter	Description	Menu	Unit
AFS	Actual Fan Speed	Readings 1	[0, 1, 2, 3, 4, 5]
APD	Actual Pressure Differential across REU	Readings 1	[Pa]
CCS	Cooling Coil Status	Readings 2	[0=out, 1=in]

Parameter	Description	Menu	Unit
CHR	Cabinet Humidity Reading	Readings 1	[%]
CIC	Cabinet customer Identification Code	Readings 2	[ASCII]
CTR	Cabinet Temperature Reading	Readings 1	[C°]
CVP	Control Valve Position	Readings 1	[%]
DRH	Data Room relative Humidity	Readings 1	[%]
DRT	Data Room Temperature	Readings 1	[C°]
EDS	ECU Doors Status	Readings 2	[0=open, 1=closed]
FGD	FPU Gas Discharged	Readings 2	[0=false, 1=true]
HSV	HMI Software Version	Readings 2	[ASCII]
MIC	Cabinet Manufacturer's Identification Code	Readings 2	[ASCII]
PPR	Permissible Pressure Reading difference	Readings 1	[Pa]
PSV	PLC Software Version	Readings 2	[ASCII]
RDS	REU Doors Status	Readings 2	[0=open, 1=closed]
RT1	Return air Temperature #1	Readings 1	[C°]
RT2	Return air Temperature #2	Readings 1	[C°]
ST1	Supply air Temperature #1	Readings 1	[C°]
ST2	Supply air Temperature #2	Readings 1	[C°]
TCH	Real Time Clock of PLC — Hours and minutes	Readings 1	[Time]
TCM	Real Time Clock of PLC — Months and days	Readings 1	[Date]
TCS	Real Time Clock of PLC — Seconds	Readings 1	[Seconds]
TCY	Real Time Clock of PLC — Year	Readings 1	[Year]

Calculations.

Parameter	Description	Menu	Unit
AAF	Actual Air Flow	Calculations	[m ³ /h]
ACC	Actual Cooling Capacity	Calculations	[kW]
ART	Average Return air Temperature	Calculations	[C°]
AST	Average Supply air Temperature	Calculations	[C°]
DRD	Data Room Dew point	Calculations	[C°]

Parameter	Description	Menu	Unit
ICD	Internal Cabinet Dew point	Calculations	[C°]
LSS	Lower limit Supply air temperature Setpoint	Calculations	[C°]
MCC	Maximum available Cooling Capacity	Calculations	[kW]
WSS	Working Setpoint for Supply air temperature	Calculations	[C°] (marked with <- on display if active)
WSR	Working Setpoint for Return air temperature	Calculations	[C°] (marked with <- on display if active)

Advanced parameters

Settings.

Parameter	Description	Menu	Unit
AGR	Automatic Gas Release	Settings	[0=false, 1=true]
ATD	Alarm Time Delay	Settings	[min]
CPG	Temperature Controller Proportional Gain	Settings	[-]
DTD	Dew point Time Delay	Settings	[min]
EOC	Entered manual Override Code	Settings	[-]
FAF	Fan Action in case of Fire	Settings	[0=false, 1=true]
FEI	Fire Extinguishing System (FES) Installed	Settings	[0=false, 1=true]
GRS	Gas Release Strategy	Settings	0=not activated 1=remote manual release 2=local manual release 3=automatic release
GTD	Gas Time Delay	Settings	[sec]
LGR	Local manual Gas Release	Settings	[0=false, 1=true]
PAL	PLC ambient Alarm Level	Settings	[C°]
PPD	Permissible Pressure reading Difference	Settings	[%]
PTD	Permissible Temperature reading Difference	Settings	[C°]
RER	Remote ECU doors Release	Settings	[0=false, 1=true]
RGR	Remote manual Gas Release	Settings	[0=false, 1=true]

Parameter	Description	Menu	Unit
RRR	Remote REU doors Release	Settings	[0=false, 1=true]
RTD	Fan Ramp-up Time Delay	Settings	[sec]
SCH	Set real time Clock of PLC — Hours and minutes	Settings	[Time]
SCM	Set real time Clock of PLC - Month and day	Settings	[Date]
SCS	Set real time Clock of PLC - Seconds	Settings	[Seconds]
SCY	Set real time Clock of PLC - Year	Settings	[Year]
SDI	Smoke Detection system (SDS) Installed	Settings	[0=false, 1=true]
STD	Fan Sequence Time Delay	Settings	[sec]
TCI	Temperature Controller Integral time	Settings	[sec]
TRD	Temperature Reaching time Delay	Settings	[min]
TRT	Temperature Reaching Tolerances	Settings	[C°]
TTD	Temperature reading Time Delay	Settings	[min]
TTS	Take over real Time clock Setting	Settings	[0=x, 1=set RTC]
VTD	Control Valve Time Delay	Settings	[min]

Readings.

Parameter	Description	Menu	Unit
DPS	Date HDCE was Put into Service	Readings	[Date] [Year]
DWS	Decreasing Working Setpoint for supply air temperature due to exceeding return air temperature	Readings	[0=off, 1=on]
IWS	Increasing Working Setpoint for supply air temperature due to condensation prevention	Readings	[0=off, 1=on]
RAC	Return Air temperature Controlling (at decreased supply air temperature) after exceeding return air temperature setpoint	Readings	[0=off, 1=on]
RTC	Return air Temperature Controlling due to unreliable supply air temperature sensors	Readings	[0=off, 1=on]
STC	Supply air Temperature Controlling at LSS due to unreliable return air temperature sensors	Readings	[0=off, 1=on]
TOH	Total number of Operational Hours	Readings	[h]

Parameter	Description	Menu	Unit
WSD	Working Setpoint for supply air temperature controlled at internal cabinet Dew point in order to achieve gradual dehumidification	Readings	[0=off, 1=on]
WSL	Working Setpoint for supply air temperature decreased to LSS	Readings	[0=off, 1=on]

Valid SMART card access codes.

Parameter	Description	Unit
C01 - C64	Valid SMART card access code #1 – #64	[BCD]
OCE	Manual Override Code for ECU access	[-]
OCR	Manual Override Code for REU access	[-]
OCT	Manual Override Code for Total access	[-]

Last used SMART card access codes.

Parameter	Description	Unit
DLC01	Date LC1 was used	[year] [date]
DLC10	Date LC10 was used	[year] [date]
TLC01	Time LC1 was used	[Time]
TLC10	Time LC10 was used	[Time]
ULC01	Last used SMART card code #1	[Date]
ULC10	Last used SMART card code #10	[Date]
VLC01	Validity of LC1	[0=invalid, 1=valid]
VLC10	Validity of LC10	[0=invalid, 1=valid]

Manual operation mode.

Parameter	Description	Unit
MOM	Manual Operation Mode	[0=false, 1=true]
MCRB	Manual Card Reader Beeper	[0=false, 1=true]
MCRG	Manual Card Reader Green LED	[0=false, 1=true]
MCRR	Manual Card Reader Red LED	[0=false, 1=true]
MCVP	Manual Control Valve Position	[0=false, 1=true]
MEMA	Manual ECU Maglocks Activation	[0=false, 1=true]
MFS1	Manual Fan Speed 1	[0=false, 1=true]
MFS2	Manual Fan Speed 2	[0=false, 1=true]
MFS3	Manual Fan Speed 3	[0=false, 1=true]
MFS4	Manual Fan Speed 4	[0=false, 1=true]
MFS5	Manual Fan Speed 5	[0=false, 1=true]
MF1A	Manual Fan 1 Activation	[0=false, 1=true]
MF2A	Manual Fan 2 Activation	[0=false, 1=true]
MF3A	Manual Fan 3 Activation	[0=false, 1=true]
MF4A	Manual Fan 4 Activation	[0=false, 1=true]
MF5A	Manual Fan 5 Activation	[0=false, 1=true]
MF6A	Manual Fan 6 Activation	[0=false, 1=true]
MGAS	Manual General Alarm Simulation	[0=false, 1=true]
MRMA	Manual REU Maglocks Activation	[0=false, 1=true]
MSRC	Manual SDU Reset Command	[0=false, 1=true]
MSVO	Manual Solenoid Valves Open	[0=false, 1=true]

View Status Readings

Status menu

Press the F1 key to access the status menu from the main menu. The status menu is a read-only menu that allows you to view HDCE readings and the results of the internal HDCE calculations, and that shows only the supply and return air temperature readings.

```
M M → F1: Status
A E   F2: Settings
I N   F3: Alarms
N U   F4: Mn. Override
```

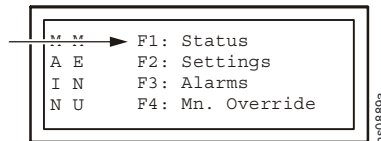

ns0889a

```
                Status menu
F1:<<           F4:Temp. °C
F2:Read
F3:Calcul.
```

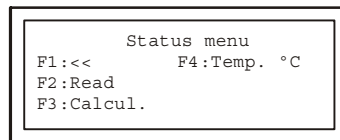

ns0890a



Note

From any screen listed under the status menu, you can use the navigational arrows to switch between all the screens available under the status menu. The screens available under the status menu are Readings 1, Readings 2, Calculations, and the Temperature Overview screen.

Readings

The Readings screen is a read-only screen that allows you to view HDCE readings. Press the F2 key from the status menu to view the Readings screen.

```
Readings 1           F1:<<
AFS = *
APD = 0 Pa
CVP = 0 %
```

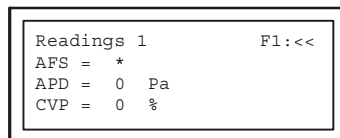

ns0891a

Calculations

The Calculations screen is a read-only screen that allows you to view the results of the internal HDCE calculations. Press the F3 key from the status menu to view the Calculations screen.

```
Calculations           F1:<<
AAF = 10 m3/h
ACC = 0.0 kW
ART = 0.0 °C
```

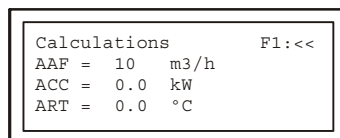

ns0892a

Temperature reading overview

The Temperature Reading Overview screen allows you to view the supply and return air temperature readings. Press the F4 key from the status menu to view the Temperature Reading Overview screen.

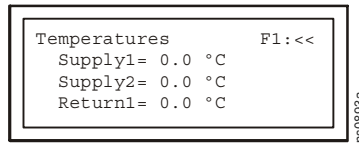

Set Up Alarms

Set up alarms for the HDCE by configuring the settings and changing the alarm thresholds for the different parameters.



See “Settings” on page 6 for more information on accessing the Settings menu.

Respond to Alarms

When an alarm is triggered, the HDCE alerts you through the local display interface and the general alarm lamp by the following methods:

- Active alarm screen
- Alarm event log in PLC
- General alarm lamp on/off

Alarms on HDCE display interface

- Smoke Pre-Alarm
 - The local display will show “Smoke Pre-Alarm” when the pre-alarm (SPA) input from the SDS unit is active. (SPA default trigger level: 0.5% smoke obscuration).
- Fire-alarm
 - The local display will show “Fire-alarm” when all of the following conditions are active:
 - The pre-alarm (SPA) input from the SDS is active.
 - The fire alarm input (SFA) from the SDS is active (SDS default trigger level: 1.5% smoke obscuration).
- Releasing-gas
 - The local display will show “Releasing-gas” when all of the following conditions are active:
 - The local gas release (LGR) command is activated.
 - The automatic gas release (AGR) command is activated.
- Gas-gone
 - The local display interface will show “Gas-gone” when the “gas-gone” signal (FGG) from the FPU fire extinguishing unit is active.

Access alarms

If the HDCE unit detects an alarm condition, this is also indicated by a red LED on the display panel. The actual alarms can be viewed and reset from the Alarm menu.

Alarm messages and suggested actions



When responding to any alarm you should always scroll back in the display through the list of alarms to identify the original alarm condition (which may have triggered other alarms as a result of its own activation).

Parameter	Displayed Alarm Message	Description	Action Suggested
AIO	Abnormal I/O module (system error)	I/O module failure	<ul style="list-style-type: none"> • Replace defective I/O module.
ATF	Cabinet Ambient Temperature sensor Fault	Failed sensor	<ul style="list-style-type: none"> • Replace sensor and/or check for loose connection.
BBF	Back-up Battery Failure	Uninterruptible power supply (UPS) batteries are empty or faulty	<ul style="list-style-type: none"> • Check 1F14 for faulty fuse and replace if necessary. • Check whether the batteries are being charged, if not check functionality of rectifier/charger. Replace rectifier/charger if malfunctioning. • Replace batteries if they are properly charged but remain faulty.
CNP	Coil Not in Place	Coil cartridge not correctly in place	<ul style="list-style-type: none"> • Check to see if the coil cartridge is secured in the proper position. Check the operation of the coil switch by activating manually.
DTF	Data room Temperature sensor Fault	Failed sensor	<ul style="list-style-type: none"> • Replace sensor and/or check for loose connection.
FCF	FPU Common Fault	Fault condition on Fire Protection Unit (FPU)	<ul style="list-style-type: none"> • Check status indicator lights on the front panel of the FPU to locate specific fault — see detailed instructions in SDU/FPU manual.
FGG	FPU Gas Gone	Indicates release of extinguishing agent into enclosure	<ul style="list-style-type: none"> • Total flood of enclosure takes 10 to 20 seconds, after which the fire should be extinguished. Do not attempt to open the enclosure until products of combustion have been extracted using a mobile vacuum pump — see detailed instructions in SDU/FPU manual.
FLP	FPU Low Pressure gas	Partially filled or leaking gas cylinder	<ul style="list-style-type: none"> • Remove defective cylinder and replace — see detailed instructions in SDU/FPU manual.
MOA	Manual Override Activated	Manual override activated	<ul style="list-style-type: none"> • Check for what reason the manual override has been activated.
MPF	Main Power Failure	Total loss of main power to ECU	<ul style="list-style-type: none"> • Check ECU power cord connection and power supply. Check breakers and check position of isolator.

Parameter	Displayed Alarm Message	Description	Action Suggested
M10-M60	Fan Motor #1 Overload	Fan motor overload	<ul style="list-style-type: none"> • Note defective fan (numbers run 1 to 6 starting with number 1 at the bottom of the ECU), remove, and replace with new fan assembly.
PBL	PLC Battery Low or empty (system error)	Defective battery or system error	<ul style="list-style-type: none"> • Replace the HDCE battery.
PNR	Pressure differential Not Reached	Very low system air resistance	<ul style="list-style-type: none"> • Check REU for missing blanking panels or lack of equipment. • Check that coil cartridge is correctly seated and secure. • Check that fans are all correctly seated and secure. • Check fan speed. If 4 or below use HDCE service software tool or local display parameter (CCS) to check coil cartridge position status. A maladjusted limit switch at the rear of the coil cartridge may result in a “coil out” status signal. This will cause the PLC to restrict the fan speed to 4 or less, which may in turn result in differential pressure not being reached. Adjust limit switch.
PSF	Pressure Sensor Fault	Failed sensor	<ul style="list-style-type: none"> • Replace defective sensor and check for loose connections.

Parameter	Displayed Alarm Message	Description	Action Suggested
PTH	PLC ambient Temperature too High	ECU PLC overheating	<ul style="list-style-type: none"> • Check to see if PLC cooling fan is operating. • If not, check fuse 2F2 and remove and replace defective fan. • If fan is operating, check if “PLC ambient temperature sensor fault” alarm is present. • If it is, replace defective sensor. • If neither of the above conditions exist, check return air sensor temperature and setpoint. This temperature should not exceed 40°C (104°F). Adjust setpoint if necessary to 40°C (104°F) or below. • If condition persists, check all fan speeds and the position of the water valve (i.e. fan speed 5, valve open 100%). Also check cooling bus supply and return temperatures (default 11°C[51.8°F]/ 16°C [60.8°F]), cooling bus water flow rate (default for ARAC15000U: 0.801/s and for ARAC15000T 0.791/s), and waterside pressure drop (default for ARAC15000U 112kPa and for ARAC15000T 109kPa). Check that the actual REU equipment load has not exceeded the enclosure’s available cooling capacity.
RHF	Room relative Humidity sensor Fault	Failed sensor	<ul style="list-style-type: none"> • Replace defective sensor and check for loose connections.
RS1-RS5	Fan speed selection relay fault (1–5)	Faulty relay	<ul style="list-style-type: none"> • Replace the defective relay indicated.
RTF	Return Temperature sensors Fault	Failed sensor	<ul style="list-style-type: none"> • Replace defective sensor and check for loose connections.

Parameter	Displayed Alarm Message	Description	Action Suggested
RTH	Return air Temperature too High	Exceeds maximum setpoint of 40°C	<ul style="list-style-type: none"> • Check setpoints for return air temperature (RTS) and pressure differential (PDS) and adjust if necessary. • Check that fans are operational. • Check the position of water valve. • Check that the actual REU equipment load has not exceeded enclosure's available cooling capacity. • Check that valve box isolation valves are fully open. • Check for any obstruction to the enclosure airway.
R1F–R2F	Return air temperature sensor #1 Fault	Failed sensor	<ul style="list-style-type: none"> • Replace defective sensor and check for loose connections.

Parameter	Displayed Alarm Message	Description	Action Suggested
SDF	SDU Fault	A fault or trouble condition exists on the FPU/SDU	<ul style="list-style-type: none"> • Check green LED on front of detector. ON indicates the detector is operating normally, FLASHING indicates the SDU/FPU firmware is starting up, and OFF indicates a TROUBLE status. If OFF: check electrical connections, if unit power is off, unit is isolated, or remote RESET asserted (unit remains off until input is de-asserted) <p>NOTE: Following the power cycle, any active alarms or will become inactive. After resetting, the SDU/FPU will regenerate any ALARMS if still present. During the first 5 seconds after reset is released the SDU reports a alarm condition until the application firmware is started. During this time the SDU will flash its OK LED.</p> <ul style="list-style-type: none"> • Check enclosure cleanliness. First check the sampling pipes and clean if dirty. Next, visually inspect the air filters. The SDU has 3 air filters with an expected operating life of 10 years in an air-conditioned computer room environment. If significant dirt is present that may block the filters. NOTE: The filters are not field serviceable. If alarms persist remove the SDU/FPU and replace with the spare unit. The defective unit can then be system tested to find its fault—note any enclosure conditions, such as any abnormal changes in airflow, which might mean normal operational parameters fall outside acceptable limits. NOTE: Failed aspirator fans are not field serviceable.
SFA	SDU Fire Alarm	Smoke detected above fire alarm threshold	<ul style="list-style-type: none"> • Remove power from the enclosure REU and ECU. The enclosure is provided with extinguishing agent release (if in manual mode). See SDU/ FPU manual for full details.

Parameter	Displayed Alarm Message	Description	Action Suggested
SPA	SDU Pre-Alarm	Smoke detected above pre-alarm threshold	<ul style="list-style-type: none"> For local site, send engineer to check enclosure and locate origin of smoke. Shut down defective device and remove from enclosure. For remote sites, prepare to power down enclosure equipment to prevent thermal incident and continue to monitor for SDU fire-alarm. See SDU/FPU Fire Alarm, above.
STF	Supply Temperature sensors Fault	Failed sensor	<ul style="list-style-type: none"> Replace defective sensor and check for loose connections.
S1F-S2F	Supply air temperature sensor #1 Fault	Failed sensor	<ul style="list-style-type: none"> Replace defective sensor and check for loose connections.
TTO	Transformer Thermal Overload	Transformer overload	<ul style="list-style-type: none"> Open REU doors to allow racked equipment to use room air to cool. Carry out controlled shutdown and remove and replace defective transformer.
VSA	Vibration sensor activated	Currently not enabled	
WLD	Water Leakage Detected	Water present in bundled area beneath coil cartridge and/ or in valve box	<ul style="list-style-type: none"> Locate presence of water and origin of source (i.e. is water present in both sensor locations or just one?) Possible sources to check in ECU coil cartridge: actuators, solenoid flow and return valves, and chilled water hoses. Possible sources to check in valve box: loose connection of any of the three valves, the strainer hood, and in particular the drain plug. In the absence of any physical equipment leaks, water may be present due to dew point problems that can occur possibly following opening of the enclosure doors in a room with an unsuitable level of humidity. Check humidity/dew point readings in the local display panel—F1 Status/Readings.

Alarm log parameters

Basic.

Parameter	Description	Menu	Unit
A01	Type of Alarm #01	Alarm	[Alarmnumber]
A10	Type of Alarm	Alarm	[Alarmnumber]

Advanced.

Parameter	Description	Unit
A01D	Date of occurrence	[Date]
A01T	Time of occurrence	[Time]
A01F1	Status fan #1 (on or off)	[0=off, 1=on]
A01F2	Status fan #2 (on or off)	[0=off, 1=on]
A01F3	Status fan #3 (on or off)	[0=off, 1=on]
A01F4	Status fan #4 (on or off)	[0=off, 1=on]
A01F5	Status fan #5 (on or off)	[0=off, 1=on]
A01F6	Status fan #6 (on or off)	[0=off, 1=on]
A01AFS	AFS (actual fan speed)	[0, 1, 2, 3, 4, 5]
A01AST	AST (average supply air temperature)	[C°]
A01ART	ART (average return air temperature)	[C°]
A01ICD	ICD (internal cabinet dew point)	[C°]
A01DRD	DRD (data room dew point)	[C°]
A01PAT	PAT (PLC ambient temperature)	[C°]
A01CVP	CVP (control valve position)	[%]
A01APD	APD (actual pressure differential across REU)	[Pa]
A01EDS	EDS (ECU doors status)	[0=open, 1=closed]
A01RDS	RDS (REU doors status)	[0=open, 1=closed]
A10D	Date of occurrence	[Date]
A10T	Time of occurrence	[Time]
A10F1	Status fan #1 (on or off)	[0=off, 1=on]
A10F2	Status fan #2 (on or off)	[0=off, 1=on]
A10F3	Status fan #3 (on or off)	[0=off, 1=on]
A10F4	Status fan #4 (on or off)	[0=off, 1=on]
A10F5	Status fan #5 (on or off)	[0=off, 1=on]

Parameter	Description	Unit
A10F6	Status fan #6 (on or off)	[0=off, 1=on]
A10AFS	AFS (actual fan speed)	[0, 1, 2, 3, 4, 5]
A10AST	AST (average supply air temperature)	[C°]
A10ART	ART (average return air temperature)	[C°]
A10ICD	ICD (internal cabinet dew point)	[C°]
A10DRD	DRD (data room dew point)	[C°]
A10PAT	PAT (PLC ambient temperature)	[C°]
A10CVP	CVP (control valve position)	[%]
A10APD	APD (actual pressure differential across REU)	[Pa]
A10EDS	EDS (ECU doors status)	[0=open, 1=closed]
A10RDS	RDS (REU doors status)	[0=open, 1=closed]

Clear alarms

View and reset alarms from the alarm menu on the display panel.

1. From the main menu screen press F3.

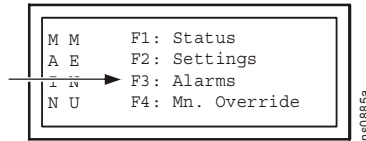

2. Press F2 to view the HDCE's current alarms. The alarm menu lists the alarm sequence number that logs in the lower right hand corner of the screen. Press F4 to clear the alarms and reset the log. The alarm LED remains lit until the alarms are cleared.

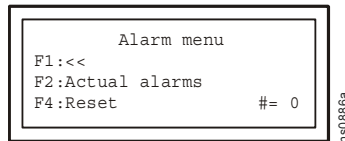

Actual alarms

The actual alarm menu can be accessed from the alarm menu screen. The actual alarm menu shows the actual alarms logged on the HDCE unit.

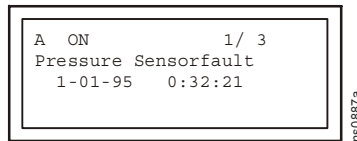

Press up navigational arrow key and down navigational arrow key to scroll through the listed alarms.

Set Up the Display

Date and time

1. Press the F4 key from the main menu screen to access the manual override code screen.

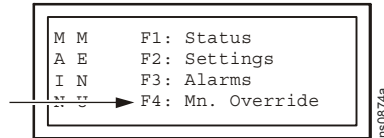

2. Press F3 to set and read the local display clock.

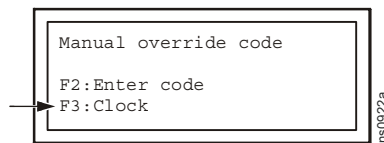

3. Press F2 to read and then display the current date and time.

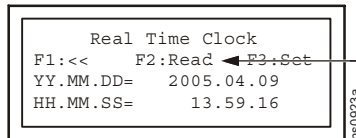

Note

The date and time displayed on the Real Time Clock screen are not automatically updated. Press F2 to update the time and date.

4. Edit the date and time by pressing the EDIT key. Move the cursor to the date or time to be edited and press the ENTER key.
5. Move the cursor to the character being changed in the date or time field by using the left and right navigational arrow keys. Use the up and down navigational arrow keys to change the characters of the date and time. When finished press the EDIT key and then the ENTER key to leave edit mode.
6. Press F3 to set and save the date and time.

Remote Monitoring Unit for HDCE

Operation



See also

See the “Environmental Monitoring Unit User’s Guide” for detailed operation instructions.

Remote Monitoring Unit alarms

Displayed Alarm	Type	Register	Parameter	Description
Fan Failure	Specific	M2004 - M2009	M10-M60	Fan motor 1 - 6 overload
Water Detected	Specific	M2019	WLD	Water Leakage Detected
Major System Alarm	General	M201E	AIO	Abnormal I/O module (system error)
Major System Alarm	General	M2001	FGG	FPU Gas Gone
Major System Alarm	General	M200C	PTH	PLC ambient Temperature too High
Major System Alarm	General	M2011	RTH	Return air Temperature too High
Major System Alarm	General	M2014	SDF	SDU Fault
Major System Alarm	General	M2015	SFA	SDU Fire Alarm
Major System Alarm	General	M201D	TTO	Transformer Thermal Overload
Major System Alarm	General	M2018	VSA	Vibration Sensor Activated
Major System Alarm	General	M2021	MPF	Main Power Failure
Major System Alarm	General	M2028	BBF	Back-up Battery Failure
Minor System Alarm	General	M201A	CTF	Cabinet Temperature sensor Fault
Minor System Alarm	General	M2010	DTF	Data room Temperature sensor Fault
Minor System Alarm	General	M2000	FCF	FPU Common Fault
Minor System Alarm	General	M2002	FLP	FPU Low Pressure gas
Minor System Alarm	General	M201F	PBL	PLC Battery Low or empty (system error)
Minor System Alarm	General	M200A	PSF	Pressure Sensor Fault
Minor System Alarm	General	M2020	PNR	Pressure differential Not Reached

Displayed Alarm	Type	Register	Parameter	Description
Minor System Alarm	General	M200B	PTF	PLC ambient Temperature sensor Fault
Minor System Alarm	General	M200D	R1F	Return air temperature sensor #1 Fault
Minor System Alarm	General	M200E	R2F	Return air temperature sensor #2 Fault
Minor System Alarm	General	M200F	RHF	Room relative Humidity sensor Fault
Minor System Alarm	General	M201C	RTF	Return Temperature sensor Fault
Minor System Alarm	General	M2012	S1F	Supply air temperature sensor #1 Fault
Minor System Alarm	General	M2013	S2F	Supply air temperature sensor #2 Fault
Minor System Alarm	General	M2016	SPA	SDU Pre-Alarm
Minor System Alarm	General	M201B	STF	Supply Temperature sensors Fault
Minor System Alarm	General	M2022	MOA	Manual Override Activated

Maintenance

Replacing Components

Fan assemblies

The HDCE has n+1 redundancy built into the fan assemblies located in the ECU enclosure. These fan assemblies are hot-swappable for rapid change and do not require unit shutdown. Sensors detect loss of or increase in air pressure at strategic locations within the airflow path to provide warning of fan failure or filter blockage. To replace a fan assembly:

1. Present an access card to the front access card reader and open the front ECU enclosure door.
2. Disconnect the snap power connector **1**, then remove the fan by releasing two quarter-turn quick-release fasteners **2**, and remove the fan **3**.

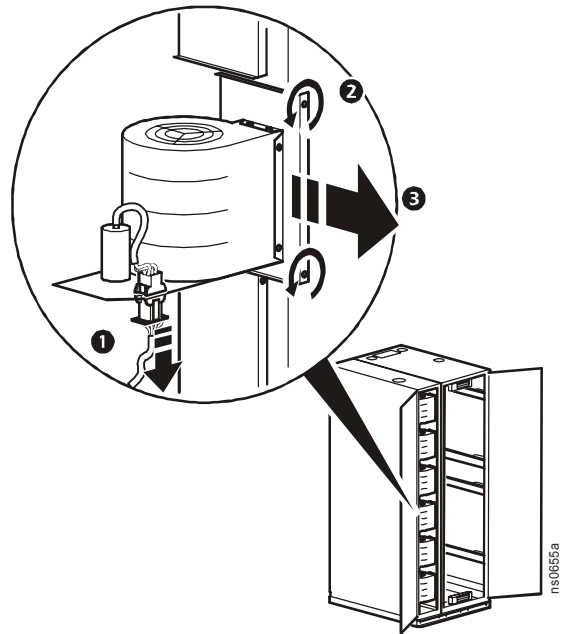

3. Insert the new fan assembly. Attach the fan by securing the two quarter-turn quick-release fasteners. Connect the snap power connector.

Cooling coil cartridge filter

Cooling coil cartridge filters can also be replaced without shutting down the unit. To replace the filter:

1. Access the HDCE from the rear ECU enclosure.
2. Open the rear ECU enclosure door and grasp the cooling coil cartridge filter. Lift the filter off of the middle bracket and toward the top of the cooling coil cartridge.

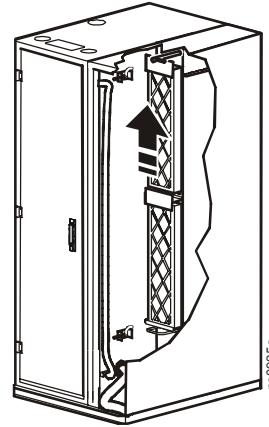

3. Pull from the bottom of the filter to remove from the cooling coil cartridge.

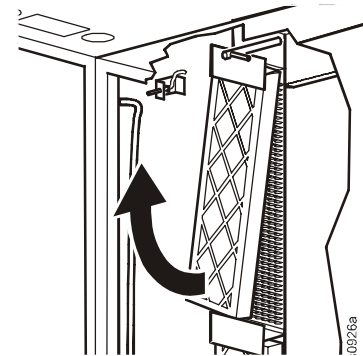

Note

Additional fan assemblies (APC part number 490-0074), cooling coil cartridges (APC part number 875-0923), and cooling coil cartridge filters (APC part number 490-0075) are available. Contact an APC customer service representative through the contact information on the back cover of this manual for ordering information.

Monthly Preventive Maintenance

Photocopy and use the pages in this section during the maintenance procedures and save them for future reference.

Prepared by: _____

Model number: _____

Serial number: _____

Date: _____



Only factory certified personnel should perform service/maintenance on this equipment.



This piece of equipment operates under pressures up to 300 kPa/44 PSI. Proper safety precautions need to be taken into consideration when connecting gauges or servicing the condenser loop/chilled water piping.



Never operate this unit with any cover, guard, door, or panel removed unless instructions indicate otherwise, and then do so with extreme caution.

Environment

In what type of room is the Module located?

Is the Module maintaining the temperature/humidity setpoint?

• Temperature setpoint _____

• Humidity setpoint _____

Is there sufficient clearance around the system for service in accordance with ASHRAE, local and national codes, and the installation manual?

Is there visible damage to the Module (dents, scratches)?

- Is there environmental damage (dirt, dust, debris, liquid stains) around the Module installation area?

- Record the room temperature and humidity adjacent to the unit.

- Temperature _____
- Humidity _____

- Record the alarm history of the last month.

Mechanical

- Ensure that all components of the blower and its motor are moving freely, with no signs of binding or damage.
- Check that all blower assemblies are correctly located in retaining brackets and secured with quick release fasteners.
- Check the chilled water supply temperature (must not be less than 11°C/51.8°F).
- Check that all hoses and cable transit seals have been correctly fitted; in particular, ensure that the data transits do not have any gaps.
- Check the filters for debris and clean or replace as needed.

Electrical

- Inspect the control panel to ensure tight connections. Using a temperature sensor verify that no terminations are excessively warm, ensuring that all connections are tight.
- Confirm that the incoming main power is within 10% of the main power requirement listed on the unit's nameplate.

Functional tests

- Ensure that the unit is maintaining temperature and humidity setpoints.
- Review the alarm history log and investigate the reason for any alarm present.

Final inspection

- Verify that the interior and exterior of the system are clean and free from debris.
- Set the control logic to match the customer's specification.
- If any parts failed during the site visit, an unscheduled maintenance (UM) form must be completed by the FSE and forwarded to APC as soon as possible.
- Ensure that the site is left clean and orderly.
- Discuss any issues or changes made with the customer so that they have a complete understanding of those issues/changes.
- Have the customer sign the form indicating that the system is on-line and completely functional.

Quarterly Preventive Maintenance

Mechanical

- Visually check the water lines for signs of leaks.
- Check that all hoses and cable transit seals have been correctly fitted. In particular, ensure that the data transits do not have any gaps.

Electrical

- Verify that no connections are loose.
- Verify the integrity of each component by measuring its nominal current. This includes fan motors. If the nominal current is greater than the current specified on the component nameplate, verify the cause and fix the problem, at which time a unscheduled maintenance form must be created.

Functional tests

- Verify the cooling cycle.
- Check the operation of the chilled water actuator.

Semi-Annual Preventive Maintenance

Cleanliness

- Clean the HDCE unit.
- Check the evaporator coil. Clean with appropriate products; for example, a commercially recognized coil cleaner that does not attack aluminum and copper metals and is environmentally safe.

Mechanical

- Check the installed optional equipment for proper mechanical operation.
- Visually check the water lines for signs of leaks.
- Check that all hoses and cable transit seals have been correctly fitted. In particular, ensure that the data transits do not have any gaps.

Electrical

- Verify that no connections are loose.
- Verify the integrity of each component by measuring its nominal current. This includes fan motors. If the nominal current is greater than the specified current on the component nameplate, verify the cause and fix the problem, at which time a unscheduled maintenance form must be created.
- Check main component connections.
- Check the installed optional equipment for proper electrical operation.

Functional tests

- Verify the cooling cycle.
- Check the operation of the chilled water actuator.
- Verify the water-regulating valve for setpoint.
- Verify the operation of the alarms of the system.

Warranty

Warranty Statement

The limited warranty provided by American Power Conversion Corporation (“APC”) in this Statement of Limited Factory Warranty applies only to Products you purchase for your commercial or industrial use in the ordinary course of your business.

LIMITED FACTORY WARRANTY

APC product covered

High-Density Cooling Enclosure

Terms of warranty

APC warrants that the Product shall be free from defects in materials and workmanship for a period of one (1) year from the date of start-up when APC authorized service personnel performed the start-up of the Product, or a maximum of 18 months from the date of Product shipment from APC, when APC authorized service personnel have not performed the start-up of the Product (“Warranty Period”). In the event that the Product fails to meet the foregoing warranty, APC shall repair or replace any defective parts, such repair or replacement to be without charge for on-site labor and travel if APC authorized personnel have conducted start-up of the Product. An APC Start-Up Service must be performed/completed by APC authorized service personnel or replacement of defective parts only will be covered. APC shall have no liability and no obligation to repair the installed Product if non-authorized personnel performed the start-up and such start-up caused the Product to be defective. Any parts furnished under this warranty may be new or factory-remanufactured. **This warranty does not cover** circuit breaker resetting, consumable, or preventative maintenance items. **Repair or replacement of a defective product or part thereof does not extend the original warranty period.**

Non-transferable Warranty extends to first purchaser for use

This Warranty is extended to the first person, firm, association or corporation (herein referred to by “You” or “Your”) for whom the APC Product specified herein has been purchased. This Warranty is not transferable or assignable without the prior written permission of APC.

Assignment of warranties

APC will assign to you any warranties which are made by manufacturers and suppliers of components of the APC Product and which are assignable. Any such warranties are assigned “AS IS” and APC makes **no representations** as to the effectiveness or extent of such warranties, assumes NO RESPONSIBILITY for any matters which may be warranted by such manufacturers or suppliers and extends no coverage under this Warranty to such components.

Drawings, descriptions

APC warrants for the Warranty Period and on the terms of the Warranty set forth herein that the APC Product will substantially conform to the descriptions contained in the APC Official Published Specifications or any of the drawings certified and agreed to by an authorized APC representative, if applicable thereto (“Specifications”). It is understood that the Specifications are **not warranties of performance** and **not warranties of fitness for a particular purpose**.

Warranty claims procedure

To obtain service under Warranty, contact APC Customer Support at (800) 800-4272. You will need the model number of the Product, the serial number, and the date purchased. A technician will ask you to describe the problem. If it is determined that the Product will need to be returned to APC you must obtain a returned material authorization (RMA) number from APC Customer Support. Products that must be returned must have the RMA number marked on the outside of the package, and be returned with transportation charges prepaid. If it is determined by APC Customer Support that on-site repair of the Product is allowed, APC will arrange to have APC authorized service personnel dispatched to the Product location to repair or replace the Product at the discretion of APC.

Exclusions

APC shall not be liable under the Warranty if its testing and examination discloses that the alleged defect in the product does not exist or was caused by your or any third person's misuse, negligence, improper installation or testing, unauthorized attempts to repair or modify, or any other cause beyond the range of the intended use, or by accident, fire, lightning or other hazard.

THERE ARE NO WARRANTIES, EXPRESSED OR IMPLIED, BY OPERATION OF LAW OR OTHERWISE, OF PRODUCTS SOLD, SERVICED OR FURNISHED UNDER THIS AGREEMENT OR IN CONNECTION HEREWITH. APC DISCLAIMS ALL IMPLIED WARRANTIES OF MERCHANTABILITY, SATISFACTION AND FITNESS FOR A PARTICULAR PURPOSE. THE APC EXPRESS WARRANTIES WILL NOT BE ENLARGED, DIMINISHED, OR AFFECTED BY AND NO OBLIGATION OR LIABILITY WILL ARISE OUT OF APC RENDERING TECHNICAL OR OTHER ADVICE OR SERVICE IN CONNECTION WITH THE PRODUCTS. THE FOREGOING WARRANTIES AND REMEDIES ARE EXCLUSIVE AND IN LIEU OF ALL OTHER WARRANTIES AND REMEDIES. THE WARRANTIES SET FORTH ABOVE, CONSTITUTE SOLE LIABILITY OF APC AND YOUR EXCLUSIVE REMEDY FOR ANY BREACH OF SUCH WARRANTIES. THE WARRANTIES EXTEND ONLY TO YOU AND ARE NOT EXTENDED TO ANY THIRD PARTIES.

IN NO EVENT SHALL APC, ITS OFFICERS, DIRECTORS, AFFILIATES OR EMPLOYEES BE LIABLE FOR ANY FORM OF INDIRECT, SPECIAL, CONSEQUENTIAL OR PUNITIVE DAMAGES ARISING OUT OF THE USE, SERVICE OR INSTALLATION OF THE PRODUCTS, WHETHER SUCH DAMAGES ARISE IN CONTRACT OR TORT, IRRESPECTIVE OF FAULT, NEGLIGENCE OR STRICT LIABILITY OR WHETHER APC HAS BEEN ADVISED IN ADVANCE OF THE POSSIBILITY OF SUCH DAMAGE.

APC Worldwide Customer Support

Customer support for this or any other APC product is available at no charge in any of the following ways:

- Visit the APC Web site to access documents in the APC Knowledge Base and to submit customer support requests.
 - **www.apc.com** (Corporate Headquarters)
Connect to localized APC Web sites for specific countries, each of which provides customer support information.
 - **www.apc.com/support/**
Global support searching APC Knowledge Base and using e-support.
- Contact an APC Customer Support center by telephone or e-mail.
 - Regional centers:

Direct InfraStruXure Customer Support Line	(1)(877)537-0607 (toll free)
APC headquarters U.S., Canada	(1)(800)800-4272 (toll free)
Latin America	(1)(401)789-5735 (USA)
Europe, Middle East, Africa	(353)(91)702000 (Ireland)
Japan	(0) 35434-2021
Australia, New Zealand, South Pacific area	(61) (2) 9955 9366 (Australia)

- Local, country-specific centers: go to **www.apc.com/support/contact** for contact information.
- Contact APC Network Air Tech Support: (1)(888)695-6500 (toll free).

Contact the APC representative or other distributor from whom you purchased your APC product for information on how to obtain local customer support.

Entire contents © 2005 American Power Conversion. All rights reserved. Reproduction in whole or in part without permission is prohibited. APC and the APC logo are trademarks of American Power Conversion Corporation and may be registered in some jurisdictions. All other trademarks, product names, and corporate names are the property of their respective owners and are used for informational purposes only.

