



The ASCO Model 5905 are resistive, AC trailer mounted (or trailer ready) load banks designed for outdoor use when up to 2500 kW of load is required.

LOAD BANK RATINGS

Standard capacity ratings

- 1000/2000 kW
- 2500 kW

Standard load step resolution of 5 kW.

Standard three phase voltage ratings

- 240/480-60Hz
- 480-60Hz

Please consult factory for non-standard ratings.

Blower Motor Control

The blowers are factory wired to the main load bus. Provisions for an external power source are also provided.

An integral 120V, 1 Phase, 60 Hz control power transformer is provided for control circuit operation.

Cooling System

Approximately 54,000 CFM cooling is provided by integral TEFC or TEAO motor which is direct coupled to the cooling fan blade. The fan motor is fully protected with fuses, motor starter contractor, and overload relay.

Load Connections

Quick connect cable receptacles are securely mounted to the cool air intake side of the load bank.

Finish

The 5905 has a high quality baked polyester powder coated finish with a film thickness of 2.8 +/- 0.4 mils per coat. The standard color is gray (ANSI 61).

Operator Controls

The standard local mode is manual control via "digital toggle" switches. The local mode features full digital monitoring and individual load steps with LED indications. The integral control panel is provided for load bank operation and includes the necessary controls and status indicators.

The optional remote control mode is via the hand-held touchscreen controller. It features a 4.3" color touch screen housed in a rugged and easy to grip industrial grade enclosure. Load selection can be the sum of the entire load string (up to 25 load banks) or individual units within that string.

Extremely fast and reliable CANbus communication protocol is used in the SIGMA LT for networking. CANbus protocol reduces network sag which is typically found in RS232 network load banks. A USB port is provided for data download and software updates.

Construction

The 5905 is constructed using heavy gauge aluminized steel per ASTM A463. It is designed for continuous outdoor weatherproof operation. Forklift channels are provided in the base for lifting.

Intake and exhaust louvers open and close with a simple swing handle and lock securely in open and closed positions with a locking pin. The louvers prevent debris from entering the load bank while in transit or storage.

All exterior fasteners are stainless steel. The main input bus, load step relays, fuses, and blower/control relays are located in the main enclosure.

Two Year Warranty Included

The equipment is covered by an industry exclusive 24-month parts and labor warranty.



"Digital Toggle" Switch Control Panel and Optional SIGMA LT Hand-Held Controller.

Model 5905 Specifications

Resistor Elements

ASCO load banks use helically wound chromium alloy Helidyne elements. Elements are fully supported across their entire length by segmented ceramic insulators on stainless steel rods. These elements are designed to operate at approximately 1/2 of their maximum continuous wire rating.

Elements are positioned within the cooling airstream for optimal performance. Changes in resistance due to temperature are minimized by maintaining conservative watt densities.

The overall load tolerance of the 5905 load bank is -0, +5%. This ensures that advertised kW is delivered at rated voltage.

The elements are continuously rated at the specific voltage. Tests at lower voltages, with a corresponding reduction in overall rating, may be carried out.

Safety Features

Differential pressure switches are interlocked with the load application controls to prevent load from being supplied if cooling air is not present.

Overtemperature switches are provided to sense the load bank exhaust. The switches are interlocked with the load application controls to disable load from being supplied if an over-temperature condition is present.

The fan motors are protected with fuses and overloads.

The adjustable louver design is a self-contain solution with the intake and exhaust louvers opening in less than 10 seconds.

Major fault protection is provided by branch circuit fuse protection. Fuse protection is provided on all load steps.

The exterior of the load bank has appropriate warning and caution statements on access panels.

Internal access is restricted by bolt on exterior panels.

The air intake on the 5905 is designed to prevent objects greater than 0.50" diameter from being ingested into the unit.

Horizontal air discharge is provided and exhaust air is directed upward away from personnel.

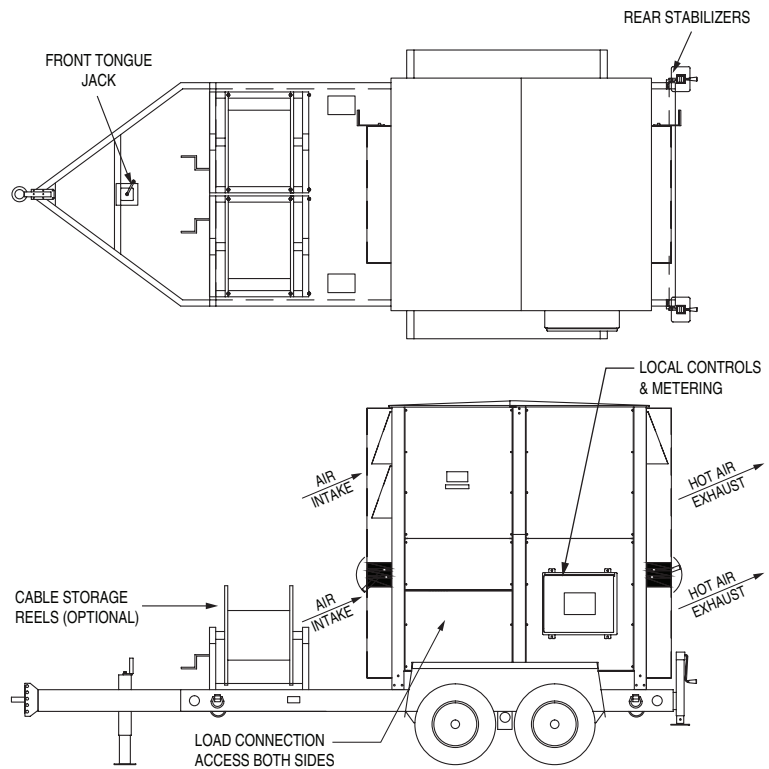

Specifications subject to change without notice.

Ambient Temperature

The 5905 load bank is designed for continuous duty cycle with no limitations. The ambient temperatures range is -20°F to 120°F (-28°C to 50°C).

Optional Trailer

If the trailer option is selected, the 5905 will be factory mounted and balanced on a DOT and ICC legal trailer. Electric brakes, stabilizer jacks and lunette eyes are provided as standard.

Optional Accessories

- 4.3" Color Touchscreen Hand-Held Controller
- 5 m Interconnection Cable (other lengths available)
- Cable Reels (Manual or Electric)
- Cable Reel Security Cover(s)
- Lockable Storage Box
- Spare Tire
- Solar Battery Charger
- Hydraulic Brakes
- 2 5/16 Ball Hitch (3" Pintle Standard)
- Custom Powder Coat Paint Finish

Support



SIGMA software can be updated free of charge through the ASCO website at the following link:

www.ascopower.com/firmware

Documentation - Operating Manual

A comprehensive operator's manual is supplied electronically via a USB drive.

Sections include: Safety, Installation, Operation, Maintenance, and Troubleshooting.

Testing and Standards

ASCO load banks comply with NEMA, NEC, and ANSI standards. Quality control system is certified to ISO9001 standards.

Weight and Dimensions

Load Bank System Dimensions (approx. in/mm)			Weight (approx. lb/kg)
Length	Width	Height	
224/5689	96/243	122/3099	6600/2994