

The ASCO Model 5500 are resistive, AC trailer mounted or trailer ready load banks designed for outdoor use when up to 500 kW of load is required.

## LOAD BANK RATINGS

### Standard capacity ratings

- 500 kW

Standard load step resolution of 5 kW.

Standard three phase voltage ratings

- 240/480-60Hz

Please consult factory for non-standard ratings.

### Blower Motor Control

The blower voltage is derived from the main load bus. 120V, 1 Phase, 60 Hz supply is provided by an integral control power transformer.

The control power transformer receives its power from the blower motor circuit.

### Cooling System

Approximately 13,000 CFM cooling is provided by integral TEFC or TEAO motor which is direct coupled to the cooling fan blade. The fan motor is fully protected with fuses, motor starter contractor, and overload relay.

### Operator Controls

The standard load control for the 5500 is a local manual panel. Controls include: Power On/Off switch, Blower Start/Stop push buttons, Master Load On/Off switch, and Individual Load Step switches. Visual indicators include: Power On, Blower On, and Blower/Air Failure.

### Digital Metering

Advanced Digital Monitoring System (ADMS) is provided for display of Volts, Amps, Frequency, and kW. ADMS also includes Data Logging Software.

### Construction

The 5500 is constructed using heavy gauge aluminized steel per ASTM A463. It is designed for continuous outdoor weatherproof operation. Forklift channels are provided in the base for lifting.

All exterior fasteners are stainless steel. The main input bus, load step relays, fuses, and blower/control relays are located in the main enclosure.

### Load Connections

Quick connect cable receptacles are securely mounted to the cool air intake side of the load bank.

### Finish

The 5500 has a high quality baked polyester powder coated finish with a film thickness of 2.8 +/- 0.4 mils per coat. The standard color is gray (ANSI 61).

### Two Year Warranty Included

The equipment is covered by an industry exclusive 24-month parts and labor warranty.

# Model 5500 Specifications

## Resistor Elements

ASCO load banks use helically wound chromium alloy Helidyne elements. Elements are fully supported across their entire length by segmented ceramic insulators on stainless steel rods. These elements are designed to operate at approximately 1/2 of their maximum continuous wire rating.

Elements are positioned within the cooling airstream for optimal performance. Changes in resistance due to temperature are minimized by maintaining conservative watt densities.

The overall load tolerance of the 5500 load bank is -0, +5%. This ensures that advertised kW is delivered at rated voltage.

The elements are continuously rated at the specific voltage. Tests at lower voltages, with a corresponding reduction in overall rating, may be carried out.

## Safety Features

A differential pressure switch is interlocked with the load application controls to prevent load from being supplied if cooling air is not present.

An overtemperature switch is provided to sense the load bank exhaust. The switch is interlocked with the load application controls to disable load from being supplied if an over-temperature condition is present.

The fan motor is protected with fuses and overloads.

Major fault protection is provided by branch circuit fuse protection. Fuse protection is provided on all load steps.

The exterior of the load bank has appropriate warning and caution statements on access panels.

Internal access is restricted by bolt on exterior panels.

The air intake on the 5500 is designed to prevent objects greater than 0.50" diameter from being ingested into the unit.

Horizontal air discharge is provided and exhaust air is directed downward away from personnel.

## Ambient Temperature

The 5500 load bank is designed for continuous duty cycle with no limitations. The ambient temperatures range is -20°F to 120°F (-28°C to 50°C).

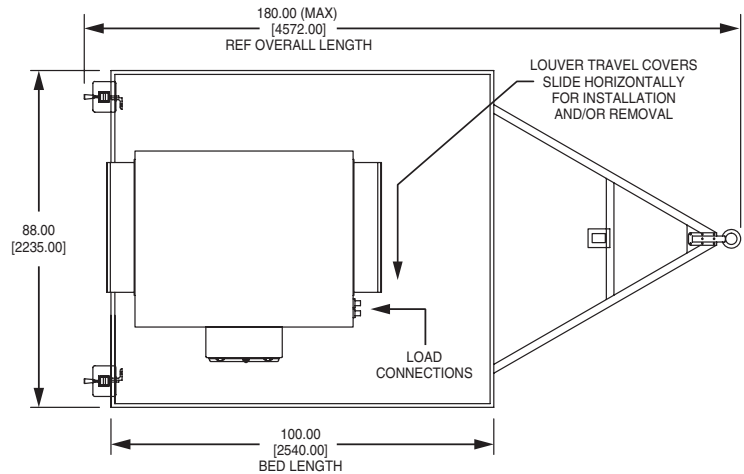
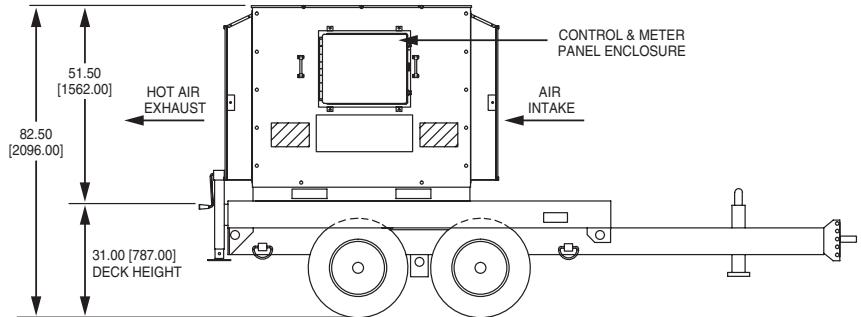

All dimensions are in inches [millimeters]. Specifications subject to change without notice.

## Optional Trailer

If the trailer option is selected, the 5500 will be factory mounted and balanced on a DOT and ICC legal trailer. Electric brakes, stabilizer jacks and lunette eyes are provided as standard.

## Optional Accessories

- Cable Reels (Manual or Electric)
- Cable Reel Security Cover(s)
- Lockable Storage Box
- SIGMA 2 Digital Controls
- Spare Tire
- Solar Battery Charger
- Hydraulic Brakes
- 2 5/16 Ball Hitch (3" Pintle Standard)
- Custom Powder Coat Paint Finish

## Documentation - Operating Manual

A comprehensive operator's manual is supplied electronically via a USB drive.

Sections include: Safety, Installation, Operation, Maintenance, and Troubleshooting.

## Testing and Standards

ASCO load banks comply with NEMA, NEC, and ANSI standards. Quality control system is certified to ISO9001 standards.

## Weight and Dimensions

Load Bank System Dimensions (approx. in/mm)			Weight (approx. lb/kg)
Length	Width	Height	
180.00/ 4572	88.00/ 2235	82.50/ 2096	3000/ 1361