

Barrier unit EXB-2000/P+F

Isolator unit EXB-2000/P+F is used in hazardous area installations.

EXB-2000/P+F is used when conventional intrinsically safe detectors and call points are connected to a conventional loop controller or addressable conventional zone module according to separate application guides.



Mechanical installation

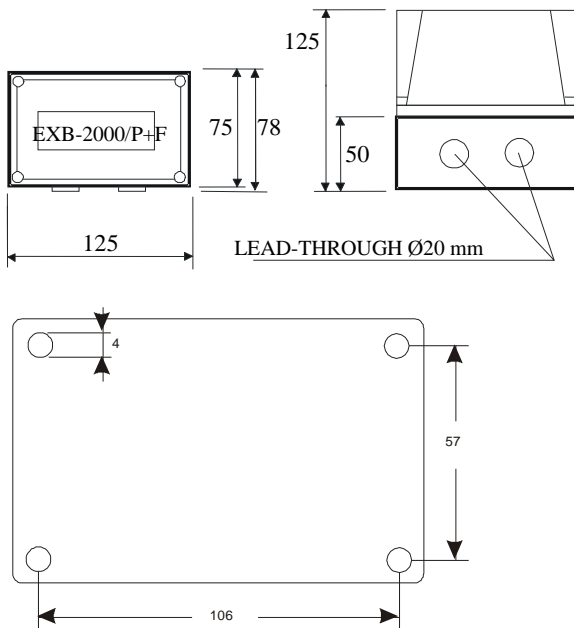

Technical specifications

Dimensions (WxHxD)	125 x 75 x 125mm
Weight	319 g
Colour	grey/green
Operating temperature-	20°C ... +100°C
Humidity	0 ... 93%
Enclosure class	IP54
Ex-isolator type	KFDO-CS-Ex1.51P
Pelco product code	FFS00438210

Approved:

(1)GD [EEx ia]IIC BAS98ATEX7343

Specifications are subject to change without notice.

Electrical connections

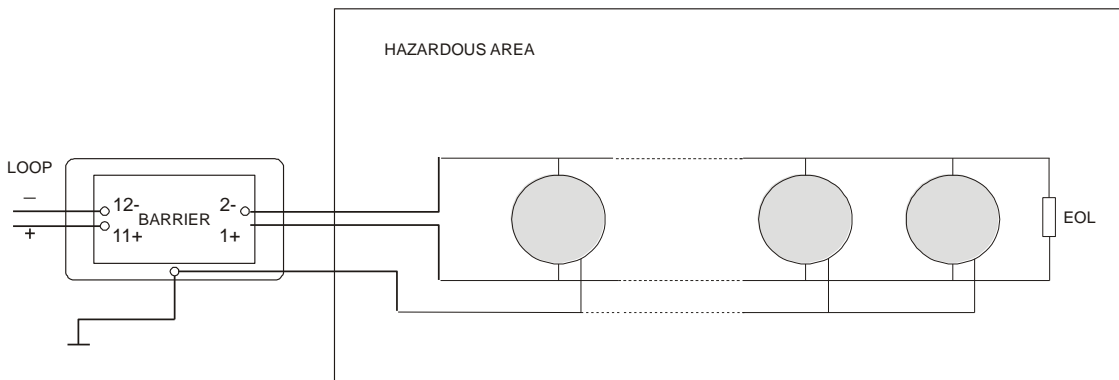

The Conventia products are compatible with the FX-CLC loop interface.

