



The ASCO Model 3020 are resistive, AC load banks designed for static or moveable installation when up to 200 kW of electrical load is required.

LOAD BANK RATINGS

Standard capacity rating:

- 200 kW

Standard load step resolution:

- 5 kW

Standard voltage rating:

- 400-50Hz

Airflow and Noise Level

Forced-air cooling is by a single plate mounted prop fan giving a horizontal hot air discharge. Fan motor is rated at 50Hz (DOL), 1.43kW at 1 phase, airflow is 2.6 m³/s (5509 CFM) and airspeed is 8.5 m/s.

Typical noise level is 69dBA at 50Hz. Measurements are taken 3 metres from the load bank and at 90° to the airflow direction. Noise readings are subject to a tolerance of ±3dBA.

Load Control

The load contactors are actuated by the specified load control system. Control is from SIGMA LT system. SIGMA LT consists of both digital toggles located on the load bank and an optional hand-held for linking load banks in a network. For more information view the SIGMA LT data sheet.

Construction

The frame of the load bank is constructed from 1.2mm mild steel, folded and pop riveted together to form a monocoque construction.

Bolted panels allow access to control and switchgear compartments.

The discharge duct contains the resistive load elements and cooling fan. The duct is double skinned and constructed with an aluminised heat shield for horizontal discharge.

A machined grille on the hot air discharge provides protection against hazardous parts to IP2X.

All electrical enclosures are to IP54. The frame contains fork lift pockets for manoeuvrability.

Finish

A durable powder coated finish is used on all panels. Standard colour is grey RAL7042.

Warranty

The equipment is covered by a 12-month warranty as detailed in our Conditions of Trade.

Model 3020 Specifications

Resistor Elements

The 3020 load banks use replaceable, non-finned sheathed elements in a 6 element block configuration. The outer sheaths are made from stainless steel to give good corrosion resistance.

The heating elements are a 80/20 nickel-chrome wire embedded in compacted magnesium oxide powder, giving good thermal and insulation properties.

The elements are very conservatively rated and there is no need for cooling fins to dissipate the heat into the airflow. This ensures that foreign matter or a loosely fitting fin cannot possibly cause hot spots and therefore ensures high reliability.

The elements are designed to operate continuously at up to 800°C (red/orange). The actual temperature is below 500°C (dull red). This gives a wide margin of safety and very long life.

Load tolerance is within 2½ % of total capacity.

Elements are continuously rated at the specific voltage. Short-term tests with fluctuations up to 10% above rated voltage are permissible. Tests at lower voltages, with a corresponding reduction in overall rating, may be carried out. Power is proportional to voltage squared.

Safety Features

An emergency stop/disconnect switch gives full isolation of the fan and control supply.

A 110 Volt AC control circuit transformer provides isolation and operator safety.

Stop/start buttons ensure the load bank will not automatically restart.

The fan motor is fully protected with fuses and a thermal overload.

The load banks have single phasing protection provided by the overload. Thermal detectors are fitted to protect against overheating in the resistive duct and switchgear enclosure.

Over voltage protection for the load circuit is provided by SIGMA LT control.

Each element group and its associated contactor are protected by an HRC fuse. This is very important when testing large capacity power supplies, due to the possible high fault currents.

The load contactors are interlocked with the fan controls to ensure load can be applied only when the fan is running.

Internal access is restricted by bolted panels. Polycarbonate screens behind the doors prevent accidental contact with live parts.

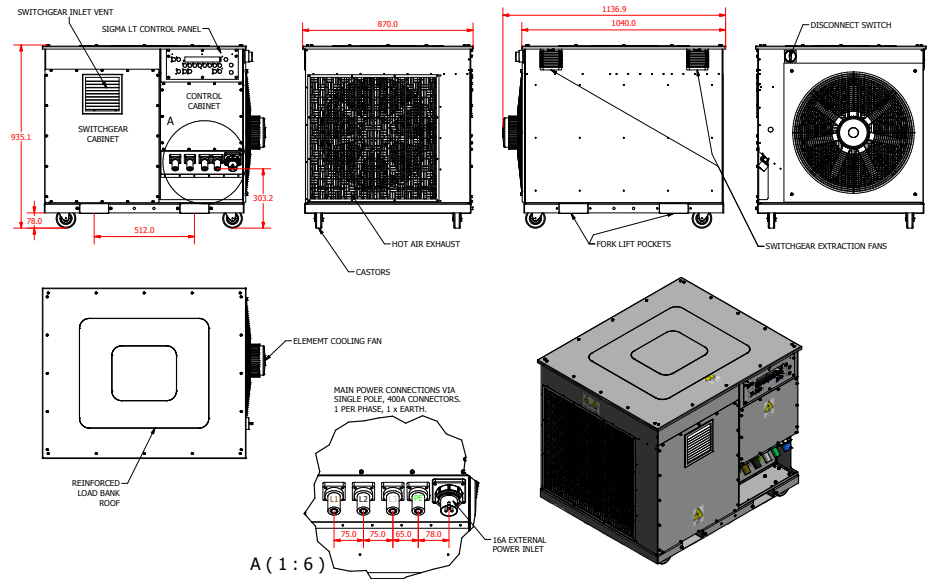

All dimensions are in millimeters. Specifications subject to change without notice.

Ambient Temperature and Humidity

Standard load banks are rated between -10°C and 40°C. Average air temperature rise 110°C.

Ambient humidity may be up to 90% RH, non-condensing.

Mounting

The load bank is mounted on 4x industrial grade swivel castors.

Power Terminals

Single pole, twist lock power connections are located in the recess below the control panel.

Auxiliary Supply

The fan and control circuit is powered from an IEC 60309-2 plug and socket auxiliary supply allowing quick and easy connection.

Documentation – Operator Handbook

A comprehensive illustrated operator's manual is supplied. Sections cover safety, installation, commissioning, operation, calibration, maintenance and fault finding.

Testing and Standards

Functional operation and load tests are completed on all load banks, before despatch, in line with our ISO 9001:2008 procedures.

ASCO load banks comply with international standards and are CE marked to confirm compliance with both the EMC and Low Voltage Directives.

Weight and Dimensions

Measurements: mm/in. and kg/lbs.

Model	3020
Length	1140/44.88
Width	870/34.25
Height (on base)	950/37.40
Approximate weight	220/485

Additional Information

An extensive range of resistive, inductive, capacitive or combined load banks of varying capacities are also available. For further information on this model or any other 3000 SERIES load bank, please contact a member of our sales team.