

ASCO Power Technologies

Engineering Application Information

WITHSTAND AND CLOSING RATINGS FOR TRANSFER SWITCH EQUIPMENT

ASCO products comply with all mandatory UL 1008 withstand and closing ratings.

By using the information in this publication and calculating available short circuit currents, the system designer can be assured the transfer switches will be properly rated for the electrical system.

Introduction

This publication provides information on withstand and closing ratings (WCRs) for ASCO transfer switches and related products, including compliance with the optional short time ratings and other revisions to UL 1008. Also included are guidelines for special WCR applications and typical methods for specifying WCR requirements.

Guidelines for using the information in this publication to verify suitability of switches for specific applications based on withstand and closing ratings (WCR).

1. Determine the prospective fault current available (from each source) at the location of the switch.
2. Determine the overcurrent protective devices (OPDs) that will be located ahead of the switch.
3. If the OPD is a circuit breaker, refer to the “Time Based” rating column on Table II of page 4. Select the switch rating necessary to handle the full load current. Compare the fault current available at the switch source terminals to the WCR shown in Table II for the applicable switch ampere size and voltage. If the prospective fault current is equal to or less than the Time Based WCR from Table II, the switch selected is suitable for the application.
4. If the prospective fault current is greater than the Time Based WCR obtained from Table II, refer to the “Specific Breaker” list on Table III on pages 5-7. Compare the fault current to the WCR shown in Table II. If the fault current is equal to or less than the WCR shown in Table II, the switch is suitable for the application when protected by any of the circuit breakers shown. If the specific circuit breaker being used is not shown in the table, contact ASCO Power Technologies.
5. If the prospective fault current is greater than the WCR listed in Table III, refer to *Special Application Considerations* on page 8.
6. When the overcurrent protective devices are fuses refer to the “Current Limiting Fuses” column of Table II on page 4. If there are any questions about the suitability of the switch when protected by current limiting fuses contact ASCO Power Technologies.

The Importance of Proper Ratings

The transfer switch is a unique and critical part of the power system. It is the last distribution device feeding the critical loads of a facility. For that reason, the transfer switch should be located as close as possible to the protected loads. In addition, after a fault (short circuit) is cleared, the transfer switch must remain operable so that it can restore power to the critical loads from the alternate power source.

In the design of an electrical power distribution system, a coordination study should be conducted during the design stage to determine the trip settings required for all circuit breakers. Proper trip settings will assure that a fault is cleared as close to its location as practical. The coordination study considers conductor sizes, quantities and lengths as well as any other relevant circuit impedance. The farther from the source a device is located, the lower the fault current will be at that device. Referring to Figure 1, a fault at point A should be cleared by the switchgear feeder breaker F_2 and not by M. This would leave the other feeder circuits (F_1 & F_3 - F_7) in operation. A coordination study will determine the magnitude of fault current at the load side of the transfer switch and indicate the settings for F_2 .

Consider a fault at point B on the load side of the

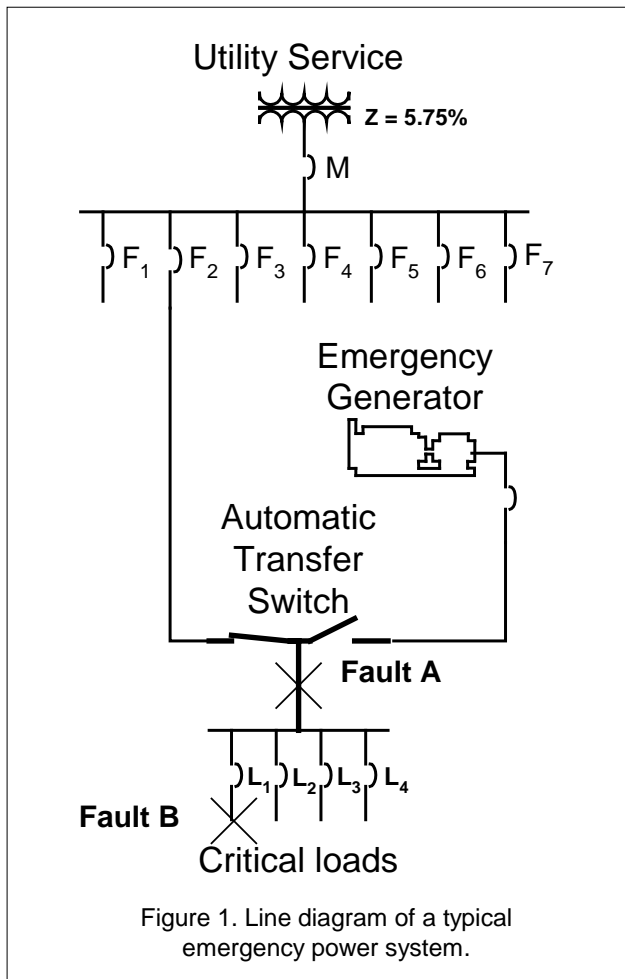

breaker feeding L_1 as shown in Figure 1. If the system breakers have been coordinated properly, the breaker feeding L_1 will trip before the upstream breaker or fuse. The transfer switch must withstand this fault current until the circuit breaker or fuse clears the fault. Most automatic transfer switches available today have a standard control circuit time delay of 0.5 seconds or more to override any momentary voltage transients. This is ample time for any over current device to clear the fault, allowing system voltage to return to normal and avoiding any unnecessary operation of the transfer switch.

Now consider a fault at point A of Figure 1. The circuit breakers on the load side of the transfer switch would not see the fault current, but the upstream breaker (F_2) would and the instantaneous trip element would be actuated. The transfer switch controller senses there is no voltage from the utility, signals a transfer operation and the transfer switch is now required to close on the fault condition until the generator over current device clears the fault.

If a transfer switch does not have a sufficient withstand and closing rating, severe damage and a potential fire hazard could result from the fault current. Over-rating the transfer switch to achieve a sufficient WCR leads to a less cost-effective design. Good engineering practice requires adequately rated devices in the power distribution system. Therefore, the specified WCR for the transfer switch should be equal to or greater than the available fault current at the location of the transfer switch. Some recommended engineering practices to assist in fault current calculations are referenced at the end of this publication.

How Codes Impact Ratings

Codes often require equipment to be approved for its intended use. For example, one of the most common applications for automatic transfer switches is in Emergency Systems per Article 700 of the National Electrical Code (NEC) ANSI/NFPA 70. Section 700-3 and 700-6 require that all transfer equipment be approved for use on Emergency Systems. How does a manufacturer obtain approval? There are several ways, but perhaps the most common is via a third party certification acceptable to the authority having jurisdiction.

The Role of Underwriters Laboratories

Underwriters Laboratories (UL) is one of several independent testing agencies and is perhaps the most well-known third party certifier. The Standard for Safety under which Underwriters Laboratories tests Transfer Switch Equipment is UL 1008. Equipment which meets UL requirements is listed in UL's *Electrical Construction Materials List*. This list is frequently used by

electrical inspectors and other authorities having jurisdiction in conjunction with the device markings and rating label to approve an electrical installation.

UL has issued several revisions to the UL 1008 Standard, which clarify how a transfer switch is to be tested and marked for fault current withstand and closing ratings. A major revision introduced in the 1989 version of UL 1008 allowed an optional rating category for WCR and closing tests. Its purpose was to permit transfer switch manufacturers to conduct tests without overcurrent protective devices. For transfer switches rated 400A and below for use on 10 kA circuit maximum, the on time of the fault current must be at least 25 ms (1½ cycles). For transfer switches rated above 400A or for use on circuits with available fault currents above 10 kA, the on time of the fault current must be at least 50 ms (3 cycles). When this test is successful, the manufacturer may mark the switch for use with any manufacturer's circuit breaker within its rating. Such *umbrella* ratings give the application engineer more flexibility when specifying and coordinating the transfer switch with overcurrent devices.

Where a transfer switch manufacturer does not opt for this test, the switch can only be marked to show the specific manufacturer's circuit breaker with which the switch was tested, or circuit breakers approved by UL through extension from the original test data. The specific breaker marking can limit the product's application and acceptance by the inspecting authority.

Other issues may develop when the transfer switch WCR is limited to use with specific circuit breakers. Even though a specific breaker is coordinated with the transfer switch upon initial installation, the breaker could possibly be replaced at a later date with another type and/or rating which is not one of the breakers approved by UL. Circuit breakers also change trip characteristics as they age and the tripping time may become slower, allowing the transfer switch to be subjected to energy above the original short circuit testing values. These issues would not be a concern to the specifying engineer if a transfer switch rated for use with "Time Based" were selected.

Another significant change regarding short circuit testing was made to UL1008 in June of 2002. Since the requirement for selective coordination was added to articles 700, 701 and 708 of the NEC, UL recognized there would be situations where transfer switches would be required to withstand and close on short circuit currents for time durations of 0.1 seconds (6 cycles for 60Hz systems). Consequently, UL added requirements for a new optional short circuit test called "Short Time Current Rating Test". The criteria for a successful test was the same as the short circuit testing in the standard,

except the test sample was required to pass a temperature rise test at the conclusion of this new short time test. This meant the transfer switch main contacts had to be virtually "like new" in order to minimize the increase in contact resistance in order to meet the temperature rise limits.

The time duration of the short time test was up to the discretion of the manufacturer and could range from 0.1 to 0.5 seconds. The amount of energy a transfer switch can withstand and close on is based on an I²T function, which is a measurement of the energy handled by the switch. Since the switch has to handle more energy with the longer time duration and also pass a temperature rise test following this event, the short time ratings will be lower for an identical test sample compared to the short circuit ratings obtained for the requirements in UL1008 prior to 2002.

The 7th Edition of UL 1008 became effective November 1, 2014 and resulted in significant changes to the short-circuit ratings shown on all transfer switch products in the industry. First, the "Any" circuit breaker rating added in 1989 was replaced with a "time based" rating and marking shown in seconds rather than cycles. Generally, these are time durations of 0.025 Sec for short-circuit currents up to 10 kA on switch ratings of 400 amp or less and 0.050 Sec for most other short-circuit levels.

The most significant change is the way that specific circuit breakers are permitted to be added to the label markings. Specific circuit breakers must be short circuit tested with the transfer switch per UL1008 requirements or can be added based on comparing circuit breaker maximum instantaneous clearing times to the actual time durations of short-circuit tests conducted on the transfer switch. UL has made this change to ensure all manufacturers utilize the criteria described in the 7th edition of UL1008 to qualify circuit breakers for use with transfer switches during short circuit testing of their products.

Unfortunately, this limits the listed population of circuit breakers on the WCR labels of many manufacturers' switches and especially on smaller frame transfer switches, because of the manner in which UL previously evaluated adding circuit breakers to manufacturer's markings. In the past, the listing of specific breakers was based on a comparison of the "published" maximum instantaneous clearing time of the breaker tested to non-tested circuit breakers maximum instantaneous clearing times.

The format and appearance of the WCR label was also changed significantly with the addition of more descriptive statements regarding how the ratings should be applied in selecting appropriate over-current protection. An example of these labels is shown on page 8.

ASCO Switches Meet and Exceed UL 1008 Requirements

ASCO Power Technologies provides withstand current ratings on its products to provide maximum flexibility to

the electrical consultant when specifying these products. The ratings apply to the ASCO products shown in Table I and are specified in Tables II and III. The ratings apply to single phase and three phase switches. The withstand & closing ratings of the overlapping neutral transfer pole is identical to the WCR of the phase switching poles.

See page 8, *Special Application Considerations*, if ratings beyond those listed are required. Contact ASCO Power Technologies to determine if ratings have been increased or for ratings beyond three cycles which may not be UL Listed, but which are based on other tests.

Table I. Applicable Products (Refer to Specific Rating Tables for Each Products Rating)

ASCO Product	Typical Applications	Product Description	
		Automatic Transfer Switch	Non-Automatic Transfer Switch
Series 165, 185	Residential	Automatic	Manual
Series 300 / 386	Industrial / Light Commercial	Automatic Transfer Switch (Light Commercial Applications)	Non-Automatic – Electrically Operated Transfer Switch
4000 TS 4000 Series Power Transfer Switches	Industrial, Commercial, Institutional	4ATS – Automatic Transfer Switch 4ACTS – Automatic Closed Transition Switch 4ADTS – Automatic Delayed Transition Switch	4NTS – Non-Automatic Transfer Switch 4NCTS – Non-Automatic Closed Transition Switch 4NDTS – Non-Automatic Delayed Transition Switch
7000 TS 7000 Series Power Transfer Switches	Health Care, Critical Power Facilities	7ATS – Automatic Transfer Switch 7ACTS – Automatic Closed Transition Switch 7ADTS – Automatic Delayed Transition Switch 7ASLS – Automatic Soft Load Transfer Switch	7NTS – Non-Automatic Transfer Switch 7NCTS – Non-Automatic Closed Transition Switch 7NDTS – Non-Automatic Delayed Transition Switch 7MTS – Manually Operated Transfer Switch
7000 TB 7000 Series Transfer Switches with Bypass-Isolation Feature	Health Care, Critical Power Facilities, Mission Critical	7ATB – Automatic Transfer Switch with Bypass-Isolation 7ACTB – Automatic Closed Transition Transfer Switch with Bypass-Isolation 7ADTB – Automatic Delayed Transition Transfer Switch with Bypass-Isolation 7ASLB – Automatic Soft Load Transfer Switch with Bypass-Isolation	7NTB – Non-Automatic Transfer Switch with Bypass-Isolation 7NCTB – Non-Automatic Closed Transition Transfer Switch with Bypass-Isolation 7NDTB – Non-Automatic Delayed Transition Transfer Switch with Bypass-Isolation

Table II. UL1008 Withstand and Closing Ratings by Switch Frame

Table II. ASCO UL1008 Withstand and Closing Ratings^{1,2,7}
(RMS Symmetrical Amps)

Frame	Switch Rating (Amps)		300, 4000 & 7000 Series						4000 & 7000 Series						7000 Series										
			Current Limiting Fuses			Specific Breaker			Time Based						Short Time Ratings ³ (sec)										
			Transfer Switches	Bypass Switches	480V Max.	600V Max.	Max Size, A	Class	240V Max.	480V Max.	600V Max.	Time (sec)	240V Max.	480V Max.	600V Max.	480V Max.	.13	.2	.3	.5	.1	.13	.3	.5	
D	30		100kA	-	300	J	22kA	22kA	10kA	0.025	10kA	10kA	10kA	10kA											
			200kA	35kA	200	J																			
			35kA	35kA	200	RK1																			
D	70, 100		200kA	35kA	200	RK1	150kA	85kA	25kA	0.025	10kA	10kA	10kA	10kA											
			200kA	35kA	200	J																			
			200kA	35kA	200	RK1																			
D	150		200kA	35kA	200	J	150kA	85kA	25kA	0.025	10kA	10kA	10kA	10kA											
			200kA	35kA	200	J																			
			200kA	35kA	200	J																			
D	200		200kA	-	200	J	200kA	85kA	14kA	0.025	10kA	10kA	10kA	10kA											
			100kA	-	300	J	200kA	85kA	14kA	0.025	10kA	10kA	10kA	10kA											
			200kA	-	600	J	65kA	42kA	35kA	0.05	35kA	35kA	35kA	22kA											
E	260, 400		200kA	-	600	J	200kA	200kA	42kA	0.05	65kA	42kA ⁵	35kA	22kA											
			200kA	200kA	800	L																			
			200kA	200kA	800	L																			
J	150, 200, 260	400	200kA	200kA	600	J	65kA	50kA	42kA	0.05	65kA	42kA ⁵	35kA	22kA											
			200kA	200kA	800	L																			
			200kA	200kA	800	L																			
J	600	600	200kA	200kA	600	J	65kA	50kA	42kA	0.05	65kA	42kA ⁵	35kA	22kA											
			200kA	200kA	800	L																			
			200kA	200kA	600	J																			
H ⁸	600	600	200kA	200kA	1600	L	65kA	65kA	65kA	0.05	50kA	50kA	50kA	50kA	36kA										
			200kA	200kA	1600	L																			
			200kA	200kA	1600	L																			
P ⁸	800	800 - 1200	200kA	200kA	1600	L	65kA	65kA	65kA	0.05	50kA	50kA	50kA	50kA	36kA										
			200kA	200kA	1600	L																			
			200kA	200kA	1600 ⁴	L																			
H	800 - 1200	800 - 1200	200kA	200kA	2000	L	65kA	65kA	65kA	0.05	50kA	50kA	50kA	50kA	36kA										
			200kA	200kA	2000	L																			
			200kA	200kA	2000	L																			
Q ⁸	600-1600	600-1600	200kA	200kA	2000	L	65kA	65kA	65kA	0.05	50kA	50kA	50kA	50kA	36kA										
			200kA	200kA	2500	L																			
			200kA	200kA	2500	L																			
S ⁸	800 - 1200	800 - 1200	200kA	200kA	2000	L	65kA	65kA	65kA	0.05	50kA	50kA	50kA	50kA	36kA										
			200kA	200kA	2500	L																			
			200kA	200kA	2000	L																			
G ⁸	1000 - 1200	1000 - 1200	200kA	200kA	2000	L	85kA	85kA	85kA	0.05	85kA	85kA	85kA	85kA	50kA										
			200kA	200kA	2000	L																			
			200kA	200kA	2000	L																			
G ⁸	1600 - 2000 (Front Connected TS Only)	1600 - 2000	200kA	200kA	2500	L	85kA	85kA	85kA	0.05	85kA	85kA	85kA	85kA	50kA										
			200kA	200kA	3000	L	125kA ⁶	125kA ⁶	100kA	0.05	100kA	100kA	100kA	100kA	36kA										
			200kA	200kA	2500	L																			
S ⁸	1600 - 2000	1600 - 2000	200kA	200kA	2500	L	100kA	100kA	85kA	0.05	100kA	100kA	100kA	100kA	85kA										
			200kA	200kA	4000	L																			
			200kA	200kA	4000	L																			
G ⁸	2600 - 3000	2600 - 3000	200kA	200kA	4000	L	100kA	100kA	100kA	0.05	100kA	100kA	100kA	100kA	85kA										
			200kA	200kA	4000	L																			
			200kA	200kA	4000	L																			
G ⁸	3200		200kA	-	4000	L	100kA	100kA	100kA	0.05	100kA	100kA	100kA	100kA	85kA										
			200kA	200kA	4000	L																			
			200kA	200kA	4000	L																			
U ⁸	4000	4000	200kA	200kA	5000	L	100kA	100kA	100kA	0.05	100kA	100kA	100kA	100kA	85kA										
			200kA	200kA	5000	L																			
			200kA	200kA	5000	L																			
U ⁸	2600 - 4000	2600 - 4000	200kA	200kA	5000	L	125kA	125kA	125kA	0.05	125kA	125kA	125kA	125kA	100kA										
			200kA	200kA	5000	L																			
			200kA	200kA	5000	L																			

Notes:
 1) All WCR values indicated are tested in accordance with the requirements of UL 1008, 7th Edition. See ASCO Pub. 1128 for more WCR information
 2) Application requirements may permit higher WCR for certain switch sizes.
 3) Short Time ratings are provided for applications involving circuit breakers that utilize trip delay settings for system selective coordination
 4) Max fuse rating is 1200A on front connected H frame switches
 5) Switches utilizing overlapping neutral (code "C") have 35kA, 0.050 Sec time based rating at 480V Max
 6) Rating shown is for Bypass switches only, Transfer Switch rating is 100kA
 7) See ASCO for Service Entrance Switch ratings
 8) These frames are only available on the 7000 Series product
 9) Short Time Rating applies to 600A Bypass switch only, the 600A Transfer Switch does not have a Short Time Rating

Table III. Withstand / Closing Ratings for Transfer Switches
Used with Specific Manufacturer's Molded Case Circuit Breaker

ASCO Transfer Switch Product	Transfer Switch Frame Prefix	Transfer Switch Rating (Amps)	WCR/Closing Rating kA RMS Symmetrical Amps	Volts Max	Circuit Breaker Manufacturer	Circuit Breaker Type or Class	Circuit Breaker Rating (Amp Max) Per NEC
------------------------------	------------------------------	-------------------------------	--	-----------	------------------------------	-------------------------------	--

300 TS 7000 TS	D	30	22	480	GE	THED	40
-------------------	---	----	----	-----	----	------	----

300 TS 4000 TS 7000 TS	D	70	150	240	Square-D	HR	250	
			125			HL	150	
			100			BJ, HJ	125	
			65			BG, HG	125	
			42			QG, QJ	90	
			25			HD	150	
			85	480		BD	125	
			50			HL, HR	150	
			35			BJ	125	
			18			HG, HJ	150	
			22			BG	125	
			22			BD, HD	125	
		25	600	GE	THED	90		
		18		Square-D	HJ, HL, HR	150		
		14			BJ	125		
					HG	150		
					BG	125		
					HD	150		
			BD		125			
		100		240	150	Square-D	HR	250
					125		HL	150
					100		BJ, HJ	125
					65		BG, HG	125
					42		QG, QJ	125
25	HD				150			
85	480			BD	125			
50				HL, HR	150			
35				BJ	125			
18				HG, HJ	150			
22				BG	125			
22				BD, HD	125			
	GE	THED	150					

			25	600	Square-D	HJ, HL, HR	150		
			18			BJ	125		
						HG	150		
				BG		125			
				HD		150			
				BD		125			
				HR		250			
			150	125		240	Square-D	HL	150
				100				BJ, HJ	125
		65		JG, JJ, JL, JR	200				
		42		BG, HG	125				
		25		QG, QJ	200				
		85		HD	150				
		50		480	Square-D			BD	125
								HL, HR	150
								BJ	125
								HG, HJ	150
								BG	125
								25	JG, JJ, JL
		200 230	240	Square-D	BD, HD	125			
					22	GE	THED	150	
					25	600	Square-D	HJ, HL, HR	150
					18			BJ	125
					14			HG	150
					200			BG	125
					125			HD	150
					100			BD	125
65	480				Square-D	JR	250		
		42	JL	250					
		25	JJ	250					
		85	JG	250					
		30	QG, QJ	225					
		18	JD	250					
14	600	Square-D	JL, JR	250					
			JG, JJ	250					
			JD	250					
			JD, JG, JJ, JL, JR		250				

300 TS	E	260 400	65	240	GE	THLC4	350
			42	480	Cutler Hammer	HMC	800

300 TS 4000 TS 7000 TS 7000 TB	J	150 200 230 260 400 600	65	240	GE	THQMV	225
					Cutler Hammer	SGL1, SGL4, SGL6, SGP1, SGP4, SGP6	600
						LDC, CLDC, HLD, CHLD	
						HLD6, HLXD6	
					Square-D	QG, QJ	250
LJ, LL, LR	600						

ASCO Transfer Switch Product	Transfer Switch Frame Prefix	Transfer Switch Rating (Amps)	WCR/Closing Rating kA RMS Symmetrical Amps	Volts Max	Circuit Breaker Manufacturer	Circuit Breaker Type or Class	Circuit Breaker Rating (Amp Max) Per NEC
------------------------------	------------------------------	-------------------------------	--	-----------	------------------------------	-------------------------------	--

300 TS 4000 TS 7000 TS 7000 TB	J	150 200 230	50	480	Cutler Hammer	HFDE, FDC, FDCE	225							
						NHH	250							
						JDC, JGU, JGX	350							
						HKD, CHKD, KDC, HKDB, CHKDB, LHH	400							
						HLD, CHLD, LDC, CLDC, LGH*, LGC*, LGU*, LGX*	600							
						HMDLB, CHMDLB	800							
					GE	SEL, SEP	150							
						SFL, SFP, FEN, FEH	250							
						TBC4	400							
						TJL4V, TJL1S-6S, TBC6, SGL1, SGL4, SGL6, SGP1, SGP4, SGP6, FGN, FGH, FGL, FGP	600							
						TB8	800							
					Siemens / ITE	HDG, LDG	150							
						HFD, HFD6, HFXD, HFXD6, HHFD6, HHFXD6, CFD6, HFG, LFG	250							
						HJD, HJD6, HJXD, HJXD6, SHJD, SHJD6, HHJD6, HHJXD6, CJD6, SCJD6, HJG, LJG, LLG	400							
						HLD6, HLXD6, HHL6, HHL6D, HHLXD6, CLD6, SHLD6, SCLD6, HLG	600							
		Square-D	HJ, HL	150										
			KC, KI, CF250L, NSF250	250										
			CK400N, CK400NN, CK400H, CK400HH, CJ400L, NSJ400	400										
			LC, DJ, DL, LI, NSJ600	600										
			MasterPact STR 28D, PK, PJ, PL	800										
			JJ (Current Limiting)	250										
			JL (Current Limiting)											
		JR (Current Limiting)												
		42	600	Cutler Hammer	JGU, JGX, JGH	250								
					KDC	400								
					LDC, CLDC	600								
					TBC4	400								
					SGL1, SGL4, SGL6, SGP1, SGP4, SGP6, FGP	600								
					HJ, HL, HG	150								
				Square-D	KI, JJ, JL, JR, CF250L	250								
					CK400H, CK400HH, CJ400L	400								
					LI, MasterPact STR 28D, PK	600								
				Siemens / ITE	HJD, CFD6	250								
HHJD6, HHJXD6, CJD6, SCJD6	400													
HHL6, HHL6D, CLD6, SCLD6, LNG, LPG, LGC*, LGU*, LGX*	600													
65														
								100						

ASCO Transfer Switch Product	Transfer Switch Frame Prefix	Transfer Switch Rating (Amps)	WCR/Closing Rating kA RMS Symmetrical Amps	Volts Max	Circuit Breaker Manufacturer	Circuit Breaker Type or Class	Circuit Breaker Rating (Amp Max) Per NEC
------------------------------	------------------------------	-------------------------------	--	-----------	------------------------------	-------------------------------	--

300 TS 4000 TS 7000 TS 7000 TB	J	260	50	480	Cutler Hammer	HFDE, FDCE, HFD, FDC, LHH	225				
						JDC, JGH, JGC, JGU, JGX	250				
						HKD, HKDB, CHKD, CHKDB, KDC	400				
						HLD, CHLD, LDC, CLDC, LGH*, LGC*, LGU*, LGX*, NHH	600				
						MDL, CMDL, HMDL, CHMDL, NGS, NGH, NGC, MDLB, CMDLB, HMDLB, CHMDLB	800				
					GE	SFL, SFP, FEN, FEH	250				
						TBC4	400				
						TBC6, TJJ4V, TJJ1S-6S, SGL1, SGL4, SGL6, SGP1, SGP4, SGP6, FGN, FGH, FGL, FGP	600				
						TBC8, TKL4V, TKH8S-12S, TKL8S-12S, SKH8, SKL8, SKP8, TB8	800				
					Siemens / ITE	HFD6, HFXD6, HHFD6, HHFXD6, CFD6, HFG, LFG	250				
						HJD6, HJXD6, SHJD6, HHJD6, HHJXD6, CJD6, SCJD6, HJG, LJG, LLG	400				
						HLD6, HLXD6, SHLD6, HHL6, HHLXD6, CLD6, SCLD6, HLG	600				
						LMD, LMD6, LMXD, LMXD6, HLMD, HLMD6, HLMXD, HLMXD6, MD, MD6, MXD6, HMG, HMD6, HMXD6, SMD6, SHMD6, CMD6, SCMD6, LMG, MG	800				
					Square-D	KI, KC, CF250L, NSF250	250				
						CK400N, CK400NN, CK400H, CK400HH, CJ400L, NSJ400	400				
						LC, DJ, DL, LJ, LL, LR, LI, NSJ600	600				
						CK800N, CK800NN, CK800H, CK800HH, MasterPact STR 28D, MJ, PK, PJ, PL	800				
						CK1000HL	1000				
						CK1200NN, CK1200HH	1200				
						JJ (Current Limiting)	250				
						JL (Current Limiting)					
					JR (Current Limiting)						
							65				
							100				
		200									

ASCO Transfer Switch Product	Transfer Switch Frame Prefix	Transfer Switch Rating (Amps)	WCR/Closing Rating kA RMS Symmetrical Amps	Volts Max	Circuit Breaker Manufacturer	Circuit Breaker Type or Class	Circuit Breaker Rating (Amp Max) Per NEC
------------------------------	------------------------------	-------------------------------	--	-----------	------------------------------	-------------------------------	--

300 TS 4000 TS 7000 TS 7000 TB	J	260	42	600	Cutler Hammer	JGU, JGX	250
						KDC	400
						LDC, CLDC	600
					GE	TBC4	400
						TBC6, SGL1, SGL4, SGL6, SGP1, SGP4, SGP6, FGP	600
						TBC8, TKL4V, TKL8S-12S, SKL8, SKP8	800
					Siemens / ITE	HJD, CFD6	250
						HHJD6, HHJXD6, CJD6, SCJD6	400
						HHL6, HHLXD6, CLD6, SCLD6	600
						HLMD6, HLMXD6, HMXD6, SHMD6, HMD6, CMD6, SCMD6, LMG, LNG, LPG, LGC*, LGU*, LGX*	800
					Square-D	KI, JL, JR, JJ, CF250L	250
						CK400H, CK400HH, CJ400L	400
						LI	600
						CK800H, CK800HH, MasterPact STR 28D, PK	800

300 TS 4000 TS 7000 TS 7000 TB	J	400	50	480	Cutler Hammer	JGH, JGC, NHH	250
						HKD, CHKD, KDC, HKDB, CHKDB, LHH	400
						CHLD, LDC, CLDC, LGH*, LGC*, LGU*, LGX*	600
						MDL, CMDL, HMDL, CHMDL, NGS, NGH, NGC, MDLB, CMDLB, HMDLB, CHMDLB	800
						NGU	1600
						TBC4	400
					GE	TBC6, TJL4V, TJL1S-6S, SGL1, SGL4, SGL6, SGP1, SGP4, SGP6, FGN, FGH, FGL, FGP	600
						TBC8, TKL4V, TKH8S-12S, TKL8S-12S, SKH8, SKL8, SKP8, TB8	800
						HFD6, HFXD6, HFG, LFG	250
					Siemens/ ITE	HJD6, HJXD6, SHJD6, HHJD6, HHJXD6, CJD6, SCJD6, HJG, LLG, LJG	400
						HLD6, HLXD6, SHLD6, HHL6, HHLXD6, CLD6, SCLD6, HLG	600
						LMD6, LMXD6, HLMD6, HLMXD6, MD6, MXD6, HMD6, HMXD6, SMD6, SHMD6, CMD6, SCMD6, HMG, LMG	800

ASCO Transfer Switch Product	Transfer Switch Frame Prefix	Transfer Switch Rating (Amps)	WCR/Closing Rating kA RMS Symmetrical Amps	Volts Max	Circuit Breaker Manufacturer	Circuit Breaker Type or Class	Circuit Breaker Rating (Amp Max) Per NEC
------------------------------	------------------------------	-------------------------------	--	-----------	------------------------------	-------------------------------	--

300 TS 4000 TS 7000 TS 7000 TB	J	400	50	480	Square-D	CK400N, CK400NN, CK400H, CK400HH, CJ400L, NSJ400	400
						LC, DJ, DL, LJ, LL, LR, LI, NSJ600	600
						CK800N, CK800NN, CK800H, CK800HH, MJ	800
						CK1000HH	1000
						PK, PJ, PL, MH, MasterPact STR 28D, CK1200HH	1200
		42	Cutler Hammer	KDC	400		
				LDC, CLDC, LGC*, LGU*, LGX*	600		
			GE	TBC4	400		
	TBC6, SGL1, SGL4, SGL6, SGP1, SGP4, SGP6, FGP			600			
	TBC8, TKL4V, TKL8S-12S, SKL8, SKP8			800			
	Siemens/ITE		HHJD6, HHJXD6, CJD6, SCJD6	400			
			HHL6, HHLXD6, CLD6, SCLD6	600			
			HLMD6, HLMXD6, HMXD6, SHMD6, HMD6, CMD6, SCMD6, LMG	800			
		LNG, LPG	1200				
	Square-D	CK400H, CK400HH, CJ400L	400				
		LI	600				
CK800H, CK800HH		800					
MasterPact STR 28D, PK		1200					

300 TS 4000 TS 7000 TS 7000 TB	J	600	50	480	Cutler Hammer	JGH, JGC, HFG, LFG	250
						HLD, CHLD, LDC, CLDC, LGH*, LGC*, LGU*, LGX*	600
						MDL, CMDL, HMDL, CHMDL, NGS, NGH, NGC, NGU, MDLB, CMDLB, NF	800
					GE	TBC6, TJL4V, TJL1S-6S, SGL1, SGL4, SGL6, SGP1, SGP4, SGP6, FGN, FGH, FGL, FGP	600
						TBC8, TKL4V, TKH8S-12S, TKL8S-12S, SKH8, SKL8, SKP8, TB8	800
						SKL12, SK12P	1200
					Siemens/ITE	HLD6, HLXD6, SHLD6, HHL6, HHLXD6, CLD6, SCLD6, HLG LLG	600
						LMD6, LMXD6, HLMD6, HLMXD6, MD6, MXD6, HMD6, HMXD6, SMD6, SHMD6, CMD6, SCMD6, HMG, LMG	800

ASCO Transfer Switch Product	Transfer Switch Frame Prefix	Transfer Switch Rating (Amps)	WCR/Closing Rating kA RMS Symmetrical Amps	Volts Max	Circuit Breaker Manufacturer	Circuit Breaker Type or Class	Circuit Breaker Rating (Amp Max) Per NEC
------------------------------	------------------------------	-------------------------------	--	-----------	------------------------------	-------------------------------	--

300 TS 4000 TS 7000 TS 7000 TB	J	600	50	480	Siemens/ITE	HND6, HNXD6, SND6, SHND6, ND6, NXD6, HNG, LNG, CND6	1200
					Square-D	LC, DJ, DL, LI, NSJ600	600
						CK800N, CK800NN, MJ	800
						MH, CK1200N, CK1200NN, CK1200H, CK1200HH, NT-H, NT-L1, NT-L, NT-LF, PK, PJ, PL	1200
						CM2000HH	2000
						CM2500HH	2500
					Cutler Hammer	JGC	250
						TBC4	400
						LDC, CLDC	600
						GE	TBC6, SGL1, SGL4, SGL6, SGP1, SGP4, SGP6, FGP
	TBC8, TKL4V, TKL8S-12S, SKL8, SKP8	800					
	SKL12, SKP12	1200					
	Siemens/ITE	HHL6, HHLXD6, CLD6, SCLD6	600				
		HLMD6, HLMXD6, HMXD6, SHMD6, HMD6, CMD6, SCMD6, LMG	800				
		HND6, HNXD6, HNG, LNG, SHND6	1200				
	Square-D	LI	600				
CK800H, CK800HH		800					
CK1000HL		1000					
CK1200H, CK1200HH, NT-H, NT-L, NT-LF, NT-L1, MasterPact STR 28D, PK		1200					

300 TS 4000 TS 7000 TS 7000 TB	H P**	600 800 960 1000 1200	65	480	Cutler Hammer	HLD, CHLD, LGH, LGC, LGU, LGX, LDC, CLDC	600
						HMDL, CHMDL, HMDLB, CHMDLB	800
						HND, CHND, NDC, CNDC, NF	1200
						NGH, NGC, NGU	1600
						RGH, RGC	2500

ASCO Transfer Switch Product	Transfer Switch Frame Prefix	Transfer Switch Rating (Amps)	WCR/Closing Rating kA RMS Symmetrical Amps	Volts Max	Circuit Breaker Manufacturer	Circuit Breaker Type or Class	Circuit Breaker Rating (Amp Max) Per NEC
------------------------------	------------------------------	-------------------------------	--	-----------	------------------------------	-------------------------------	--

300 TS 4000 TS 7000 TS 7000 TB	H P**	600 800 960 1000 1200	65	480	GE	TBC6, TJL4V, SGL, SGP6	600	
						TBC8, SKL8, SKP8	800	
						SKL12, SKP12, TKL4V	1200	
					Siemens/ ITE	HLXD6, HHLXD6, HHL6, CLD6, SHLD6, SCLD6, HLG, LLG	600	
						HMXD6, HMD6, SHMD6, HMG, LMG, CMD6, SCMD6	800	
						SHND6, CND6, HNXD6, HNG, LNG	1200	
						HPG, LPG, HPD, HPD6, CPD6, HPXD, HPXD6, SHPD, SHPD6	1600	
						HRD6, HRXD6	2000	
					Square-D	LI, LE LSI, LE LI, LX, LXI, LJ, LL, LR	600	
						MJ, ME, MX, CK800H, CK800HH	800	
						CK1000HL	1000	
						NT-L1, NT-L, NT-LF, NE, NX, CK1200H, CK1200HH, PJ, PL	1200	
						NW, RJ, RL	1600	
						PE, PX	2500	
						SES, SE, SEH (LS or LSI TRIP)	3000	
						SE (LI, LSI-E, and LI-E TRIP)	4000	
					600	Cutler Hammer	MasterPact STR 28D	6300
							TRI-PAC NB	800
				RDC		2500		
				Siemens/ ITE	CND	1200		

7000 TB	G	1600 2000	125	480	Square-D	Master Pact NW-L	3000
---------	---	--------------	-----	-----	----------	------------------	------

*: With Digitrip 310+ LS or LSG Inst. Override set to 12X
** : P Frames only available as 7000TS and 7000TB

Marking Requirements

UL requires markings on each switch listing the approved short circuit ratings for each product and its ampacity. ASCO switches display rating labels similar to the one shown in Figure 2.

Special Application Considerations

ASCO Power Technologies provides a line of switches which are highly reliable, utilize latest technology, include features most frequently used by the consulting engineer, and which are rated to meet a wide variety of requirements. For special applications, such as when higher ratings or longer withstand times are needed, the system designer can consider several rating alternatives:

1. Consider relocating the switch closer to the load where the added impedance of the feeder conductors will reduce the available fault current to an acceptable level. This is consistent with good engineering practice of locating transfer switches as close to the load as possible in order to minimize the risk of conductor failures between the load side of the switch and the utilization equipment.
2. Use current limiting fuses or current limiting circuit breakers to reduce fault currents.
3. Use a larger ampacity switch with a higher withstand/closing rating.
4. When the overcurrent protective device ahead of the transfer switch has a clearing time exceeding three cycles, a zone selective interlocking scheme may be considered. Such a scheme permits intentional delays to be over-ridden and the breaker to trip instantaneously whenever the fault is within the breaker's zone of primary protection.
5. Contact ASCO Power Technologies to determine if additional ratings are available.

How To Specify Withstand and Closing Ratings

Calculated values of available fault current should be specified for each transfer switch based on its location in the electrical system. This will assure that a properly rated switch will be applied and avoid specified ratings which are too low for the actual location (resulting in an unsafe practice or ratings which are too high (resulting in unnecessarily higher costs).

A growing number of specifying professionals are adding fault current withstand and closing current tables to the electrical plans showing the calculated values for each switch. A typical arrangement is shown in Table IV.

Table IV. Typical Listings of Transfer Switch Fault Current Ratings on an Electrical Plan

Transfer Switch Ident. No.	No. of Poles	Switched Neutral Y/N	Transfer Switch Ampacity	System Voltage	Calculated Fault Currents		Type of OCD
					RMS Sym. Amperes	X/R Ratio	
ATS-E8	4	Y	260	480/277	29,000	2.3	MCCB

ATS-E9	3	N	400	480	33,000	2.3	MCCB
ATS-LS1	4	Y	100	480/277	7,300	2.1	MCCB
ATS-LS2	4	Y	150	480/277	8,900	2.4	MCCB
ATS-EQ1	3	N	1000	480	48,000	3.2	MCCB

Importance of X/R Ratio

The circuit reactance to resistance ratio (X/R) is a determinant in preparing fault current studies. Consideration should be given to the X/R ratio at each transfer switch location. The actual X/R ratio should not exceed the X/R ratio at which the transfer switch was tested. Table V shows the power factor test requirements of UL 1008 with equivalent X/R ratios. If an application requires higher X/R ratios, consider the *Special Application Considerations* previously discussed or consult ASCO Power Technologies for a recommendation. By using the information in this

publication and calculating short circuit currents, the system designer can be assured that the transfer switches will be properly rated for the electrical system.

Table V. UL Maximum Test Factor with Equivalent X/R Ratio

Available Fault Current (amperes)	Maximum Test Power Factor	Equivalent X/R Ratio
10,000 or less	0.50	1.73
10,001 – 20,000	0.30	3.18
greater than 20,000	0.20	4.90

Suggested Fault Current Study Reference Guides

1. The Institute of Electrical and Electronics Engineers, Inc., *IEEE Recommended Practice for Protection and Coordination of Industrial and Commercial Power Systems*, IEEE Buff Book, ANSI/IEEE Std. 242-1986, New York, N.Y., pp. 45-113.
2. The Institute of Electrical and Electronics Engineers, Inc., *IEEE Recommended Practice for Electric Power Distribution for Industrial Plants*, IEEE Red Book, ANSI/IEEE Std. 141-1993, New York, N.Y., pp. 109-184.
3. The Institute of Electrical and Electronics Engineers, Inc., *IEEE Recommended Practice for Power System Analysis*, IEEE Brown Book, ANSI/IEEE Std. 399-1990, New York, N.Y., pp. 171-194.
4. The Institute of Electrical and Electronics Engineers, Inc., *IEEE Recommended Practice for Emergency and Standby Power Systems for Industrial and Commercial Applications*, IEEE Orange Book, ANSI/IEEE Std. 446-1995, New York, N.Y., pp. 175-196.
5. The Institute of Electrical and Electronics Engineers, Inc., *IEEE Recommended Practice for Electric Systems in Health Care Facilities*, IEEE White Book, ANSI/IEEE Std. 602-1996, New York, N.Y., pp. 50-51; 72-74.
6. Frank W. Kussy and Jack L. Warren, *Design Fundamentals for Low-Voltage Distribution and Control*, Marcel Dekker Inc., pp. 104-117, 1987.
7. Hermann W. Reichenstein, *Applying Low-Voltage Fuses—Classes and Characteristics*, McGraw-Hill Inc., 1979.

In addition to the above, most manufacturers of overcurrent protective devices can provide application data on calculating short circuit currents. Various software packages are also available to assist the application engineer in performing calculations by computer.

ASCO Power Technologies, Florham Park, New Jersey 07932 USA
800-800-2726 (ASCO) www.ascopower.com

Publication 1128 R25

© ASCO Power Technologies 2019

Printed in U.S.A.