



主要信息

产品系列	Phaseo
产品类型	电池模块
蓄电池容量	7 Ah

补充信息

输入电压限制	21...29 V
储能时间	72 小时
负载电流	0.7 A
自放电速率	9 %, 3 个月 3 %, 1 个月 15 %, 6 个月
输出耦合	并联
工作海拔	2000米
标识	CE
净重	6.5 Kg

环境

产品认证	CTP[RETURN]JUL
运行温度	0...40 °C
贮存环境温度	-20...50 °C

包装单位

Unit Type of Package 1	PCE
Number of Units in Package 1	1
Package 1 Height	19.500 Cm
Package 1 Width	20.000 Cm
Package 1 Length	26.500 Cm
Package 1 Weight	6.173 Kg
Unit Type of Package 2	S06
Number of Units in Package 2	12
Package 2 Height	75.000 Cm
Package 2 Width	60.000 Cm
Package 2 Length	80.000 Cm
Package 2 Weight	87.308 Kg

可持续性

REACH法规	REACH 声明
欧盟ROHS指令	不适用，超出欧盟 RoHS 法定范围
中国 ROHS 管理办法	中国 ROHS 声明
环境披露	产品环境文件
流通资料	产品使用寿命终期信息
无 PVC	是

合同保修

保修单	18 months
-----	-----------

24 Vdc 电池模块

尺寸

$\frac{\text{mm}}{\text{inch}}$

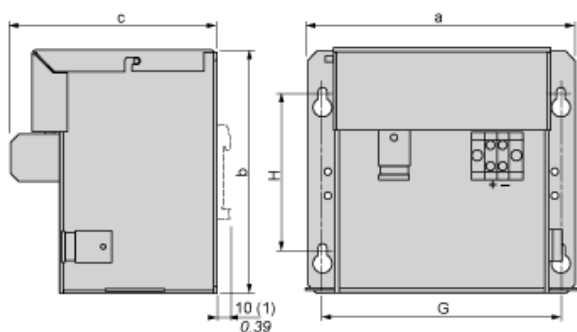

ABL	a	b	c	G	H
8BPK24A03	184/7.24	138,5/5.45	131	156/6.14	83/3.27
8BPK24A07	170/6.69	155,5/6.12	131	152/5.98	100/3.94
8BPK24A12	236/9.29	155,5/6.12	131	218/3.94	100/3.94

(1) ABL8BPK24A03 (带套件 ABL1A02)

24 Vdc 电池模块

安装

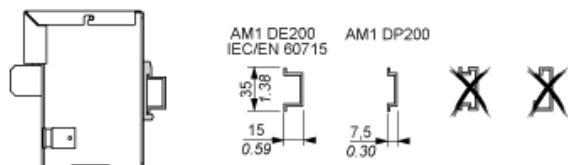

接线要求

电缆类型和接线规格

	ABL 8BPK24A00 ABL 8BPK24A01 ABL 8BPK24A02 ABL 8BPK24A03 ABL 8BPK24A04 ABL 8BPK24A05 ABL 8BPK24A06 ABL 8BPK24A07 ABL 8BPK24A08 ABL 8BPK24A09 ABL 8BPK24A10 ABL 8BPK24A11 ABL 8BPK24A12 ABL 8BPK24A13 ABL 8BPK24A14 ABL 8BPK24A15 ABL 8BPK24A16 ABL 8BPK24A17 ABL 8BPK24A18 ABL 8BPK24A19 ABL 8BPK24A20 ABL 8BPK24A21 ABL 8BPK24A22 ABL 8BPK24A23 ABL 8BPK24A24 ABL 8BPK24A25 ABL 8BPK24A26 ABL 8BPK24A27 ABL 8BPK24A28 ABL 8BPK24A29 ABL 8BPK24A30 ABL 8BPK24A31 ABL 8BPK24A32 ABL 8BPK24A33 ABL 8BPK24A34 ABL 8BPK24A35 ABL 8BPK24A36 ABL 8BPK24A37 ABL 8BPK24A38 ABL 8BPK24A39 ABL 8BPK24A40 ABL 8BPK24A41 ABL 8BPK24A42 ABL 8BPK24A43 ABL 8BPK24A44 ABL 8BPK24A45 ABL 8BPK24A46 ABL 8BPK24A47 ABL 8BPK24A48 ABL 8BPK24A49 ABL 8BPK24A50 ABL 8BPK24A51 ABL 8BPK24A52 ABL 8BPK24A53 ABL 8BPK24A54 ABL 8BPK24A55 ABL 8BPK24A56 ABL 8BPK24A57 ABL 8BPK24A58 ABL 8BPK24A59 ABL 8BPK24A60 ABL 8BPK24A61 ABL 8BPK24A62 ABL 8BPK24A63 ABL 8BPK24A64 ABL 8BPK24A65 ABL 8BPK24A66 ABL 8BPK24A67 ABL 8BPK24A68 ABL 8BPK24A69 ABL 8BPK24A70 ABL 8BPK24A71 ABL 8BPK24A72 ABL 8BPK24A73 ABL 8BPK24A74 ABL 8BPK24A75 ABL 8BPK24A76 ABL 8BPK24A77 ABL 8BPK24A78 ABL 8BPK24A79 ABL 8BPK24A80 ABL 8BPK24A81 ABL 8BPK24A82 ABL 8BPK24A83 ABL 8BPK24A84 ABL 8BPK24A85 ABL 8BPK24A86 ABL 8BPK24A87 ABL 8BPK24A88 ABL 8BPK24A89 ABL 8BPK24A90 ABL 8BPK24A91 ABL 8BPK24A92 ABL 8BPK24A93 ABL 8BPK24A94 ABL 8BPK24A95 ABL 8BPK24A96 ABL 8BPK24A97 ABL 8BPK24A98 ABL 8BPK24A99 ABL 8BPK24A00	ABL 8BBU24200 ABL 8BBU24400
ABL 8BPK24A00 - mm²/AWG: 6/10	ABL 8BPK24A00 - mm²/AWG: 10/16	
Ø 5,5 mm/0.22 in	Nm: 1,7 Nm max lb-in: 15	

24 Vdc 电池模块接线

接线图

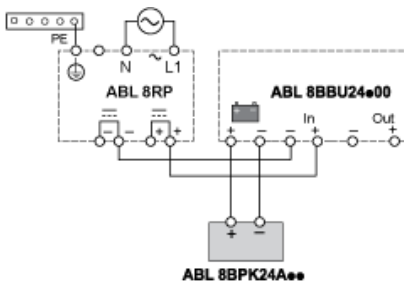

并联 2 个 ABL8BPK24A00

接线图

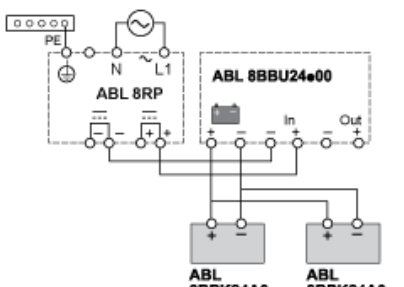

Product Life Status : Commercialised