

ZBE1015 / ZBE1025

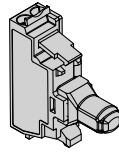

ZBVB15 / ZBVG15 /
ZBVJ15 / ZBVM15

Mounting
Montage
Montage
Montar
Montaggio

➔ 1 2 ➔

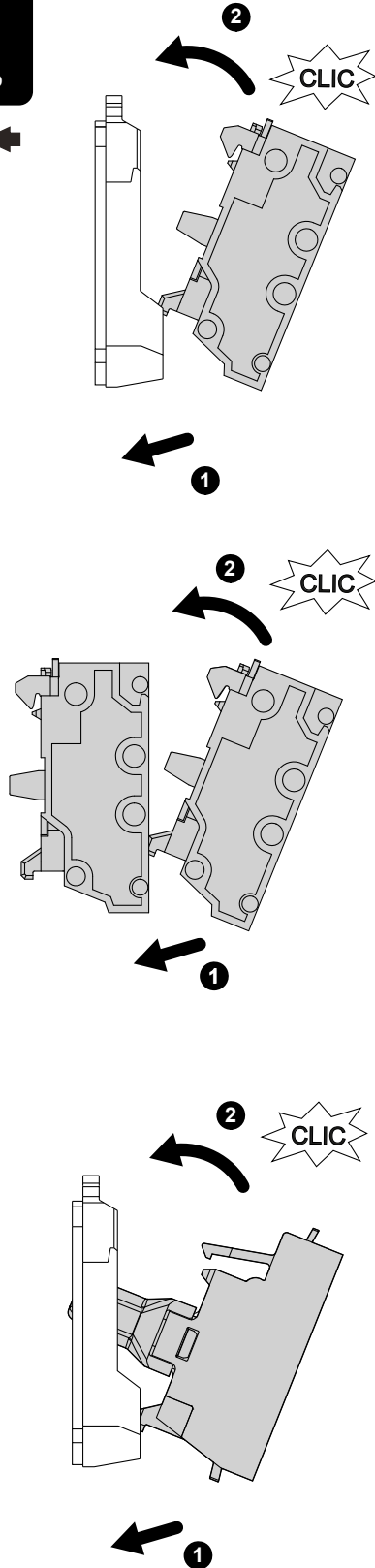

Unmounting
Démontage
Demontage
Desmontaje
Smontaggio

➔ 3 4 ➔

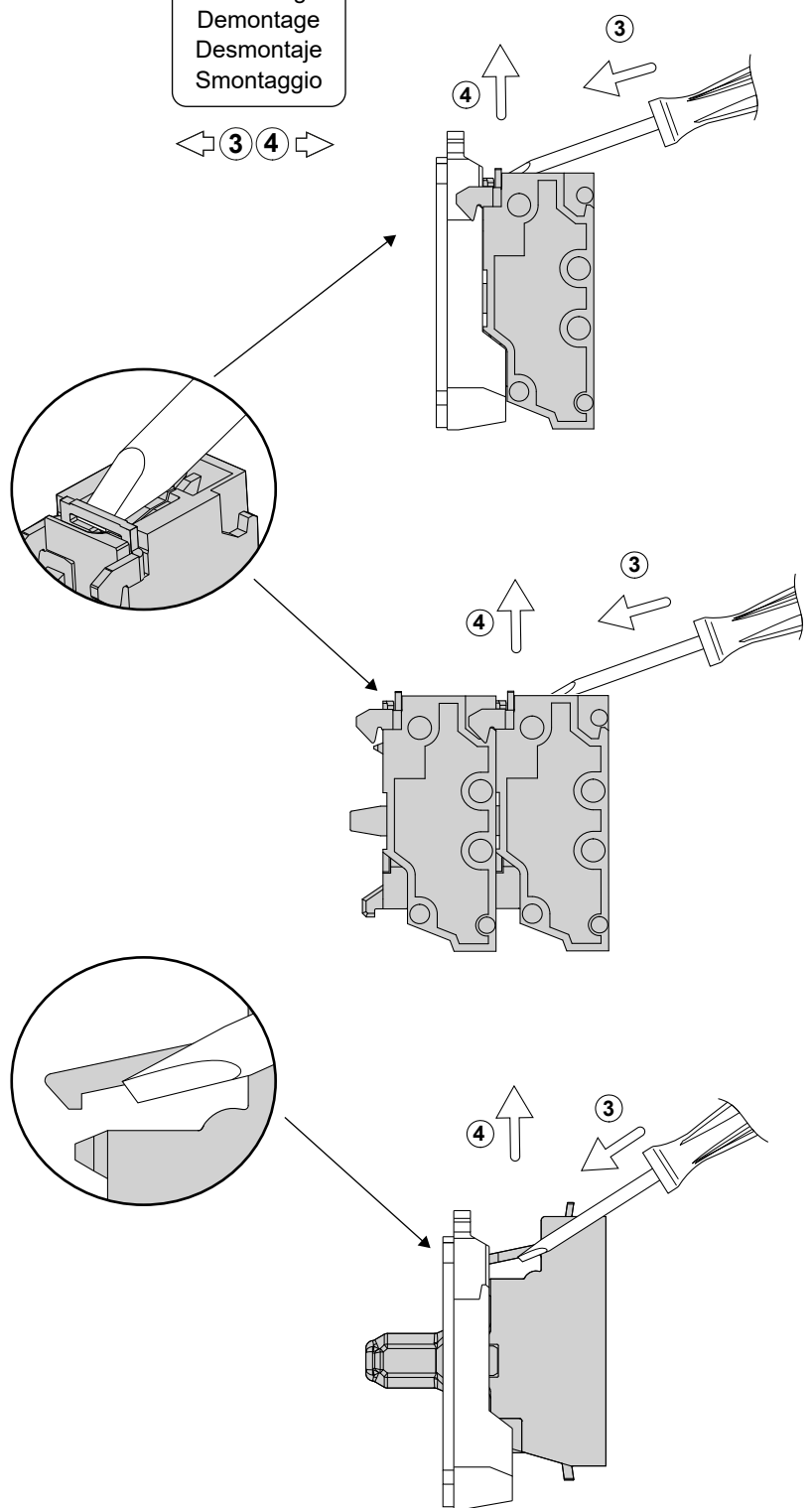



Compatibility / Compatibilité / Kompatibilität / Compatibilidad / Compatibilità

⚠ WARNING \ WARNUNG \ AVERTISSEMENT \ ADVERTENCIA \ AVVERTIMENTO

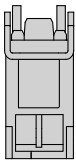

ZBE1015 / ZBE1025
 Push-in contact block
 Bloc-contact enfichable par pression
 Steckkontaktblock
 Bloque de contactos de inserción
 Blocco di contatto a innesto

Screw clamp contact block
 Bloc-contact à pince vissée
 Schraubkontaktblock
 Bloque de contactos de abrazadera con tornillo
 Blocco di contatto morsetto a vite

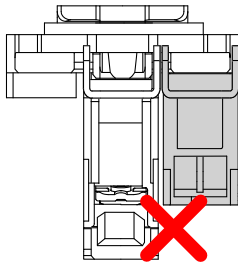
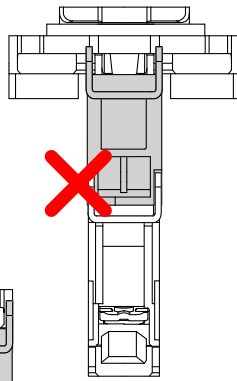
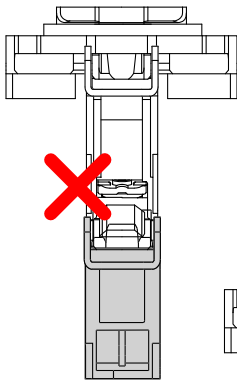
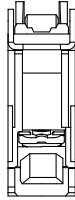

UNINTENDED EQUIPMENT OPERATION DUE TO INSULATION DISTANCE NOT RESPECTED

Do not combine with contact blocks other than ZBE1015 and ZBE1025 (stacked or side by side).

Failure to follow these instructions can result in death, serious injury, or equipment damage.

FONCTIONNEMENT INATTENDU DE L'EQUIPEMENT SUITE AU NON-RESPECT DE LA DISTANCE D'ISOLATION

Ne pas combiner avec des blocs de contacts autres que ZBE1015 et ZBE1025 (empilés ou côte à côte)

Le non-respect de ces instructions peut entraîner la mort, des blessures graves ou des dommages matériels.

UNBEABSICHTIGTER GERÄTEBETRIEB AUFGRUND VON NICHT EINGEHALTENEM ISOLATIONSABSTAND

Nicht mit anderen Kontaktblöcken als ZBE1015 und ZBE1025 kombinieren (gestapelt oder nebeneinander)

Die Nichtbeachtung dieser Anweisungen kann Tod, schwere Verletzungen oder Materialschäden zur Folge haben.

FUNCIONAMIENTO INESPERADO DEL EQUIPO AL NO RESPETAR LA DISTANCIA DE AISLAMIENTO

No lo combine con bloques de contactos distintos de ZBE1015 y ZBE1025 (apilados o uno al lado del otro)

Si no se siguen estas instrucciones, podrían ocasionarse lesiones graves o mortales, o daños en el equipo.

FUNZIONAMENTO IMPREVISTO DELL'APPARECCHIATURA A CAUSA DEL MANCATO RISPETTO DELLA DISTANZA DI ISOLAMENTO

Non combinare con unità di contatto diverse da ZBE1015 e ZBE1025 (impilate o affiancate).

Il mancato rispetto di queste istruzioni può provocare rischio di morte, gravi ferite o danni alle apparecchiature.

Panel cut-out / Découpe du panneau / Montageausschnitt / Recorte del panel / Sezione pannello

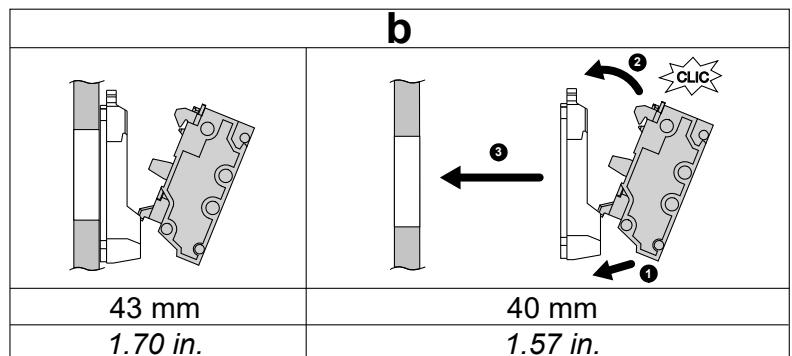
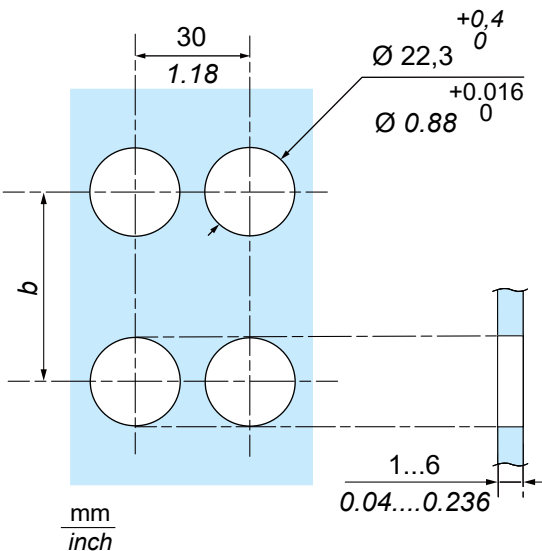

Except for
 Sauf pour
 Außer für
 Excepto para
 Tranne per

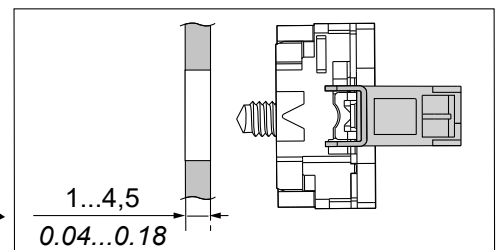



Wiring
Câblage
Verdrahtung
Cableado
Cablaggio

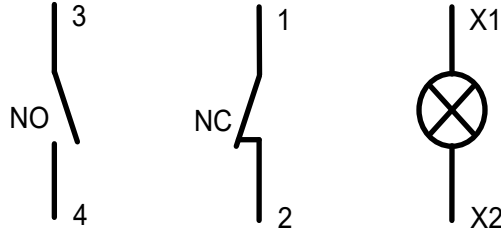

Unwiring
Déconnexion
Lösen der Verdrahtung
Retirada del cableado
Scollegamento

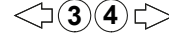

mm in.	8 0.32
mm ² AWG	0,34...1,5 22...16

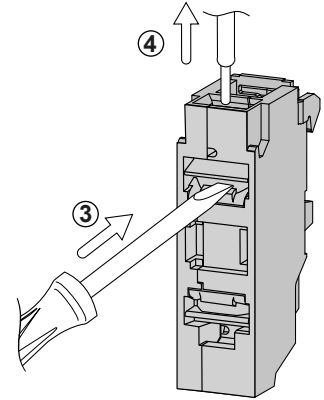
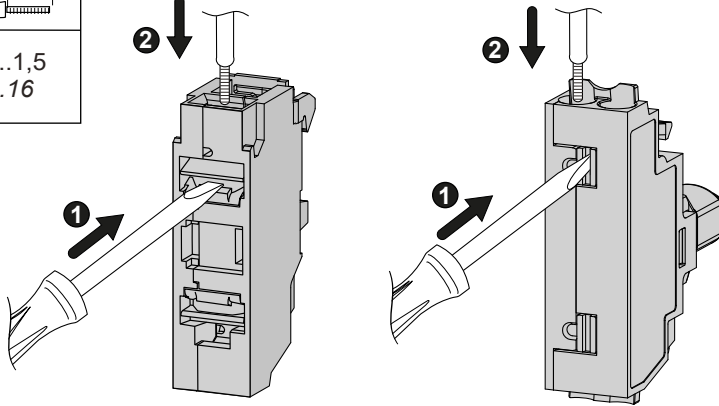

mm in.	8 0.32	8 0.32	8 0.32	(1) Maximum connectable crimping size:
mm ² AWG	0,34...1,5 22...16	0,34...1 22...18 (2 wires)	0,34...1,5 22...16 (1 wire)	

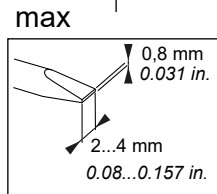
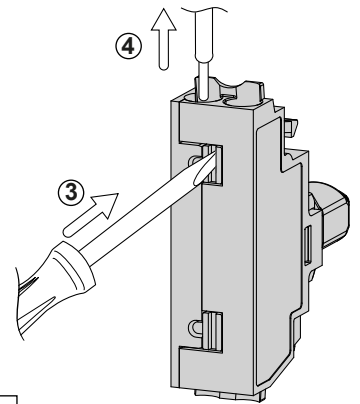
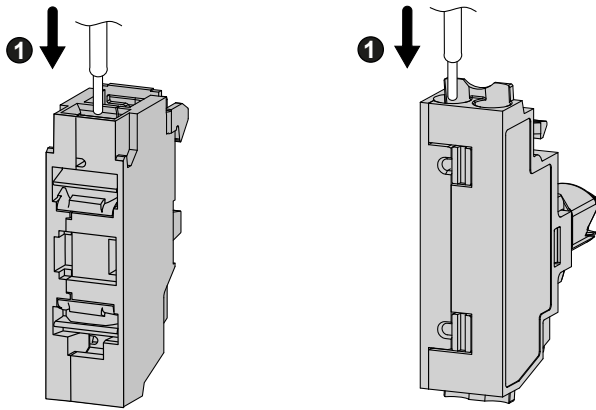

⚠️ DANGER / DANGER / GEFAHR / PELIGRO / PERICOLO

HAZARD OF ELECTRIC SHOCK, EXPLOSION OR ARC FLASH

Comply with the wiring specification above.

Failure to follow these instructions will result in death or serious injury.

RIESGO DE ELECTROCUCIÓN, EXPLOSIÓN O ARCO ELÉCTRICO

Siga las especificaciones de cableado que se muestra arriba de este mensaje.

Si no se siguen estas instrucciones provocará lesiones graves o incluso la muerte.

RISQUE D'ELECTROCUTION, D'EXPLOSION OU D'ARC ÉLECTRIQUE

Respectez les spécifications de câblage ci-dessus.

Le non-respect de ces instructions provoquera la mort ou des blessures graves.

RISCHIO DI SCOSSA ELETTRICA, DI ESPLOSIONE O DI OFTALMIA DA FLASH

Rispettare lo specifiche di cablaggio riportato sopra di questo messaggio.

Il mancato rispetto di queste istruzioni provocherà morte o gravi infortuni.

STROMSCHLAG-, EXPLOSIONS- ODER LICHTBOGENGEFAHR

Beachten Sie die oben aufgeführten Verkabelungsspezifikationen.

Die Nichtbeachtung dieser Anweisungen führt zu Tod oder schwerer Körperverletzung.



Electrical test / Test électrique / Elektrische Prüfung / Prueba eléctrica / Test elettrico

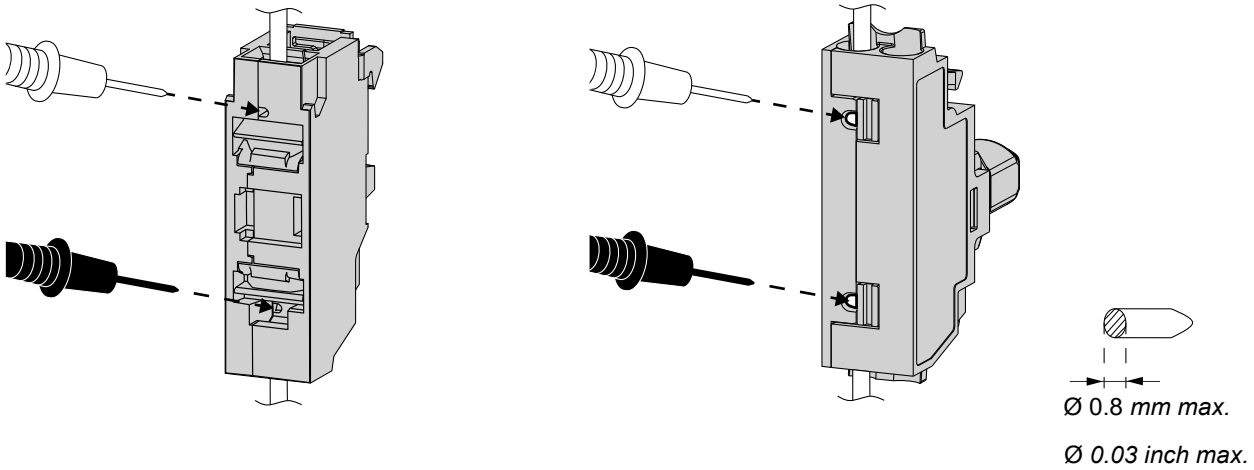

⚠️ DANGER / DANGER / GEFAHR / PELIGRO / PERICOLO

HAZARD OF ELECTRIC SHOCK, EXPLOSION OR ARC FLASH

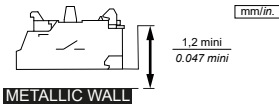

Failure to follow these instructions will result in death or serious injury.

RISQUE D'ELECTROCUTION, D'EXPLOSION OU D'ARC ELECTRIQUE

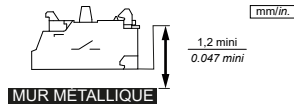

Le non-respect de ces instructions provoquera la mort ou des blessures graves.

STROMSCHLAG-, EXPLOSIONS- ODER LICHTBOGENGEFAHR

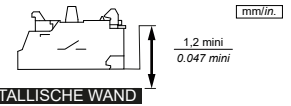

Die Nichtbeachtung dieser Anweisungen führt zu Tod oder schwerer Körperverletzung.

RIESGO DE ELECTROCUCIÓN, EXPLOSIÓN O ARCO ELÉCTRICO

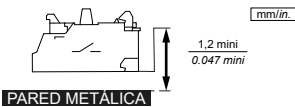

Si no se siguen estas instrucciones provocará lesiones graves o incluso la muerte.

RISCHIO DI SCOSSA ELETTRICA, DI ESPLOSIONE O DI OFTALMIA DA FLASH

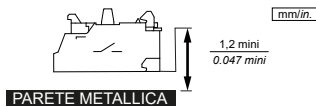

Il mancato rispetto di queste istruzioni provocherà morte o gravi infortuni.

- en** Electrical equipment should be installed, operated, serviced, and maintained only by qualified personnel. No responsibility is assumed by Schneider Electric for any consequences arising out of the use of this material.
- fr** Les équipements électriques doivent être installés, exploités et entretenus par un personnel qualifié. Schneider Electric décline toute responsabilité quant aux conséquences de l'utilisation de ce matériel.
- de** Elektrische Geräte dürfen nur von Fachpersonal installiert, betrieben, gewartet und instand gesetzt werden. Schneider Electric haftet nicht für Schäden, die aufgrund der Verwendung dieses Materials entstehen.
- es** Sólo el personal de servicio cualificado podrá instalar, utilizar, reparar y mantener el equipo eléctrico. Schneider Electric no asume las responsabilidades que pudieran surgir como consecuencia de la utilización de este material.
- it** Le apparecchiature elettriche devono essere installate, usate e riparate solo da personale qualificato. Schneider Electric non assume nessuna responsabilità per qualunque conseguenza derivante dall'uso di questo materiale.

© 2024 Schneider Electric. All Rights Reserved.

UK CA **UK Representative:**
Schneider Electric Limited
Stafford Park 5
Telford, TF3 3BL, UK

EAC **Уполномоченный поставщик в Республике Казахстан:**
ТОО «Шнейдер Электрик»
Адрес: 050010, РК, г. Алматы, пр. Достык, 38, бизнес-центр «Кен дала», 5 этаж, левое крыло.
Тел. +7 727 339 23 57

Қазақстан Республикасында ресми жеткізуші:
ЖШС «Шнейдер Электрик»
Мекен-жайы: 050010, ҚР, Алматы қ., Достық даңғылы 38, «Кен дала» бизнес орталығы, 5 қабат, сол қанат.
Тел. +7 727 339 23 57

