

PREMSET

IP41 option

EN *Installation instructions*

PHA2386701_REV00

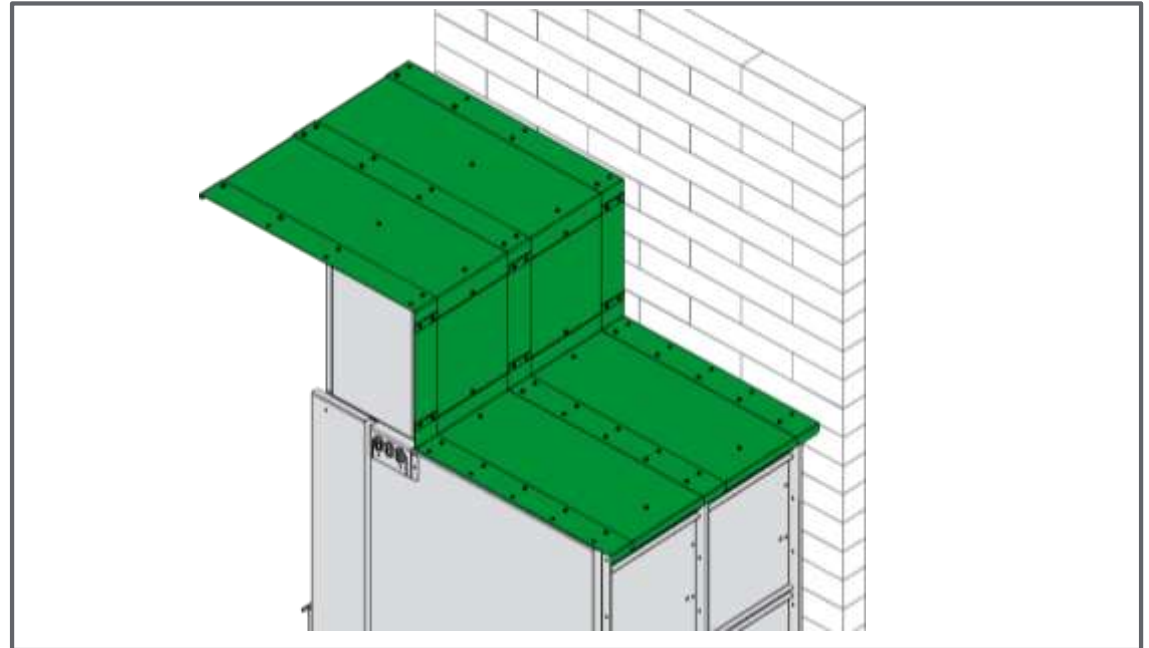



Preliminary step

Preparation
before assembly

S1

Assembly

S2

4 Configurations

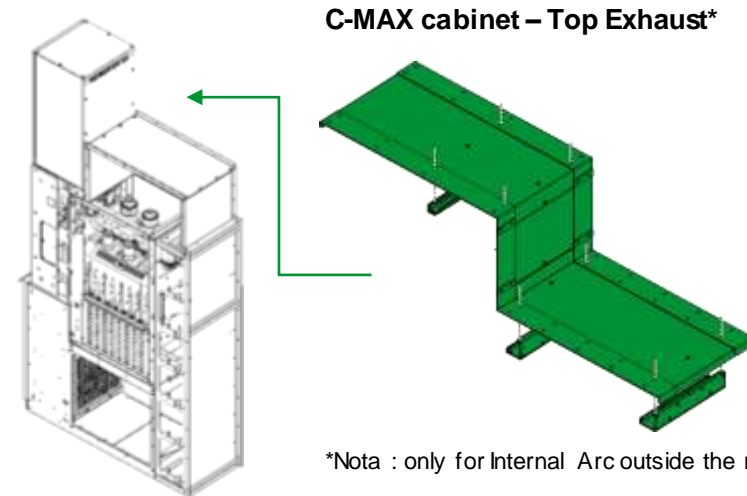
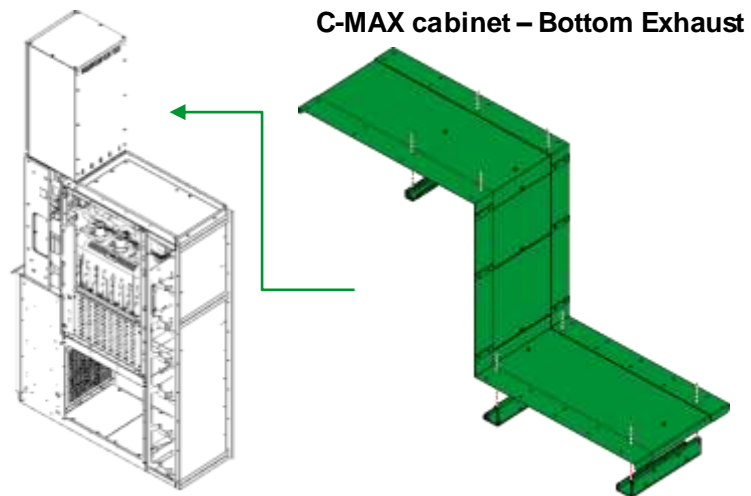
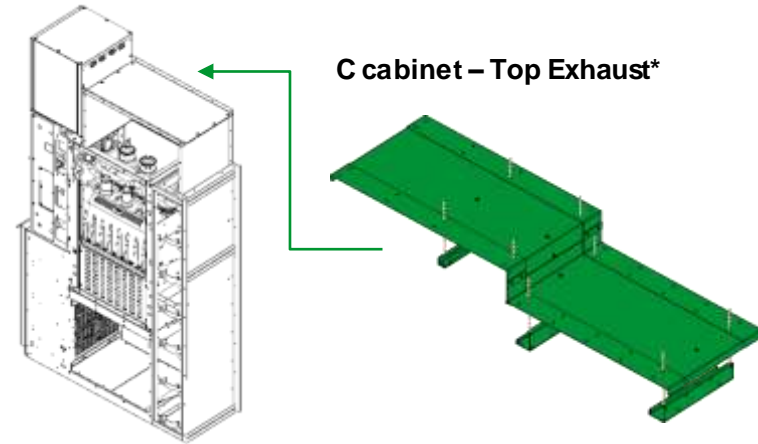
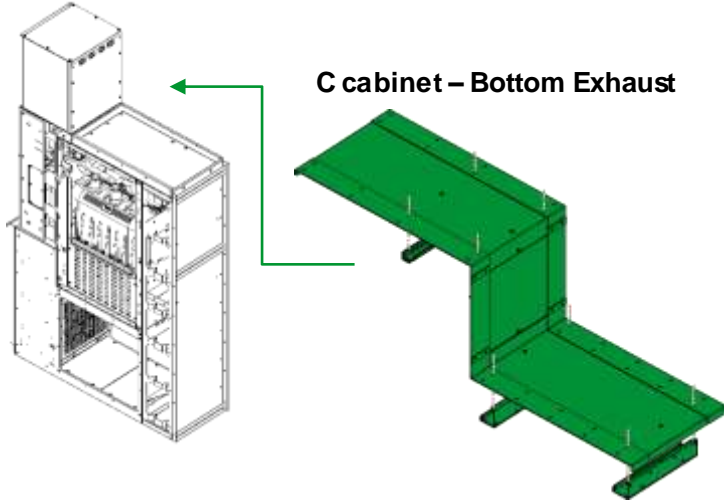

*Nota : only for Internal Arc outside the room version



Preliminary step

S0

Preparation before assembly

S1

Assembly

S2

Ref : PHA2386701-Rev.00

Kits descriptions

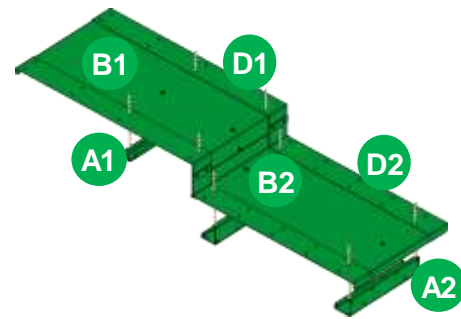
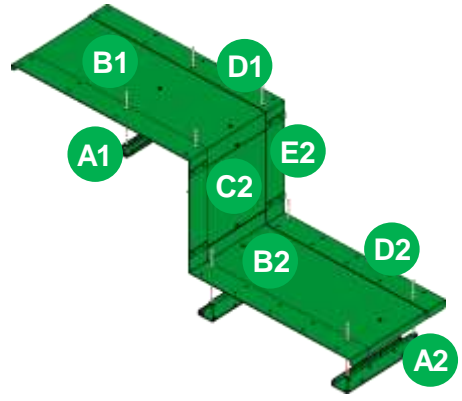
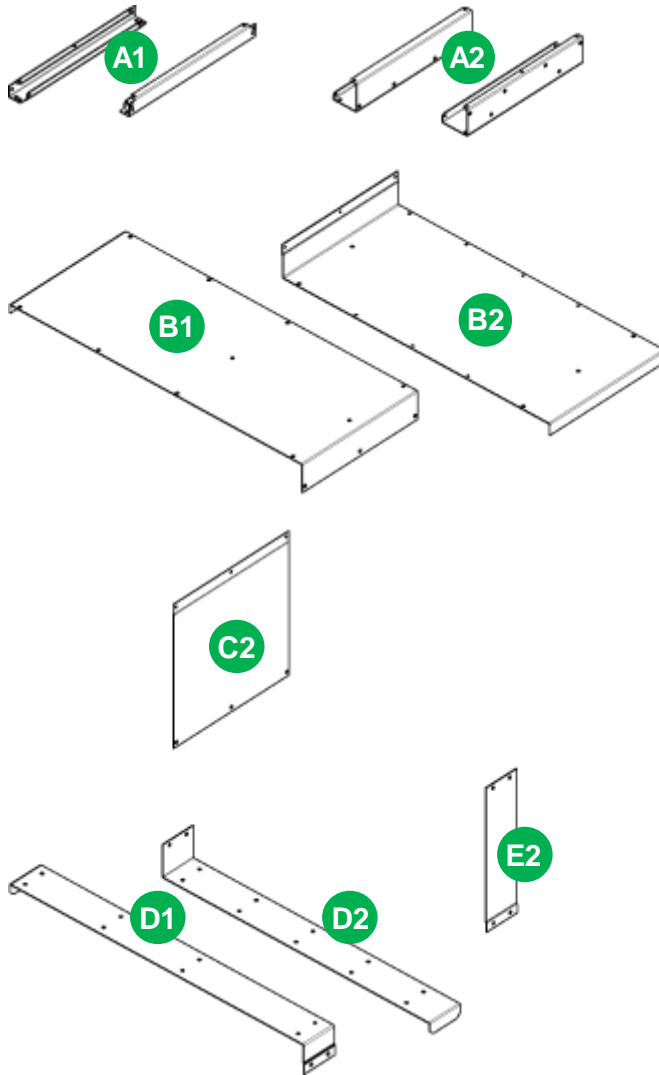

Screw bag

Item	Designation	Qty
QGH92214	Self-tapping screw M6x13	x31
	HV6x16 screws	x12
	CS washers	x12
	Grooved flanged nut	x12
QGH92221	Plastic rivets	x24

C cabinet – Bottom Exhaust

Item	Designation	Qty
A1 A2	Support assembly	x1
B1 B2	Horizontal roof	x1
C2	Vertical roof	x1
D1 D2	Horizontal end-of-table banners	x2
E2	Vertical end-of-table banners	x2

C cabinet – Top Exhaust

Item	Designation	Qty
A1 A2	Support assembly	x1
B1 B2	Horizontal roof	x1
D1 D2	Horizontal end-of-table banners	x2



Preliminary step

S0

Preparation before assembly

S1

Assembly

S2

Ref : PHA2386701-Rev.00

Kits descriptions

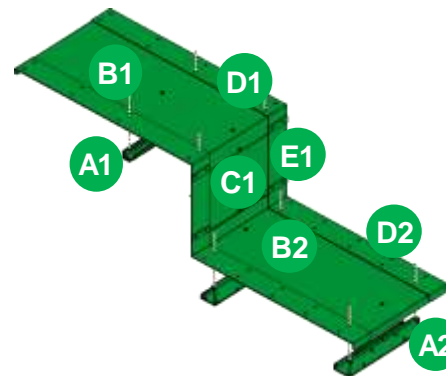
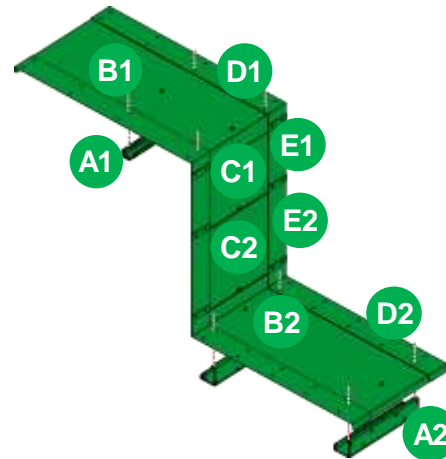
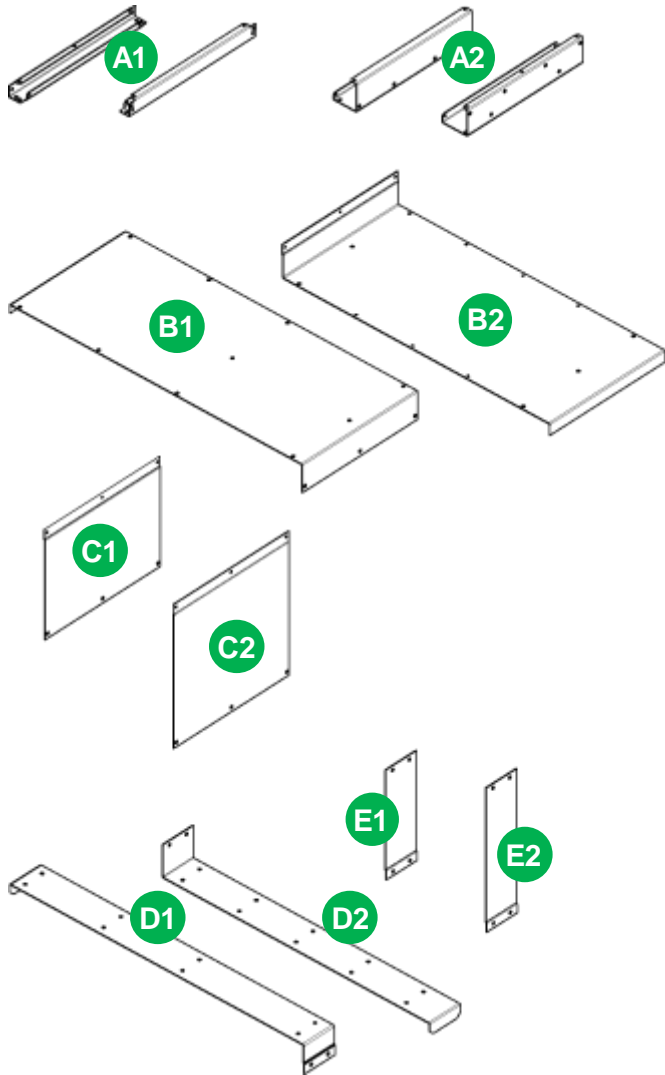

Screw bag

Item	Designation	Qty
QGH92214	Self-tapping screw M6x13	x31
	HM6x16 screws	x12
	CS washers	x12
	Grooved flanged nut	x12
QGH92221	Plastic rivets	x24

C-MAX cabinet – Bottom Exhaust

Item	Designation	Qty
A1 A2	Support assembly	x1
B1 B2	Horizontal roof	x1
C1 C2	Vertical roof	x1
D1 D2	Horizontal end-of-table banners	x2
E1 E2	Vertical end-of-table banners	x2

C-MAX cabinet – Top Exhaust

Item	Designation	Qty
A1 A2	Support assembly	x1
B1 B2	Horizontal roof	x1
C1	Vertical roof	x1
D1 D2	Horizontal end-of-table banners	x2
E1	Vertical end-of-table banners	x1



Preliminary step

S0

Preparation before assembly

S1

Assembly

S2

Ref : PHA2386701-Rev.00

Symbols and conventions



This is the safety alert symbol. It is used to alert you to potential personal injury hazards. Obey all safety messages that follow this symbol to avoid possible injury or death.



The addition of this symbol to a Danger or Warning safety label indicates that an electrical hazard exists, which will result in personal injury if the instructions are not followed.

Caution: you will find all the symbols below throughout the document, indicating the hazard levels depending on the different types of situation.

 	DANGER
<i>DANGER indicates a hazardous situation which, if not avoided, will result in death or serious injury.</i>	
	WARNING
<i>WARNING indicates a hazardous situation which, if not avoided, could result in death or serious injury.</i>	
	CAUTION
<i>CAUTION indicates a hazardous situation which, if not avoided, could result in minor or moderate injury.</i>	
	NOTICE
<i>NOTICE is used to address practices not related to physical injury.</i>	

General safety rules



DANGER

HAZARD OF ELECTRIC SHOCK, EXPLOSION, OR ARC FLASH.

- Apply appropriate personal protective equipment (PPE) and follow safe electrical work practices. See NFPA 70E or CSA Z462.
- This equipment must only be installed and serviced by qualified electrical personnel.
- Turn off all power supplying this equipment before working on or inside equipment.
- Always use a properly rated voltage sensing device to confirm power is off.
- Replace all devices, doors and covers before turning on power to this equipment.
- Beware of potential hazards, and carefully inspect the work area for tools and objects that may have been left inside the equipment.

Failure to follow these instructions can result in death, serious injury, or equipment damage.

Consignation

Consult the Operating Manual P7M18009 for the consignment of cubicle.



Preparation before assembly

Cabinet C – Bottom Exhaust

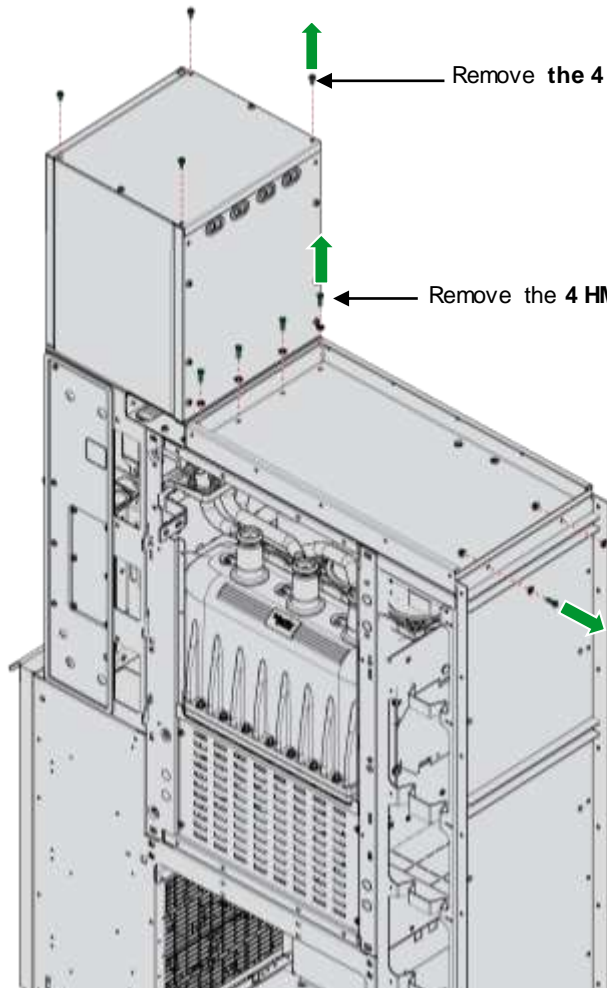

Remove the 4 self-tapping screws M6x13*.



Remove the 4 HM6x16 screws CS washers.*



Remove the 2 HM6x16 screws, CS washers, grooved flanged nuts.*

Cabinet C – Top Exhaust

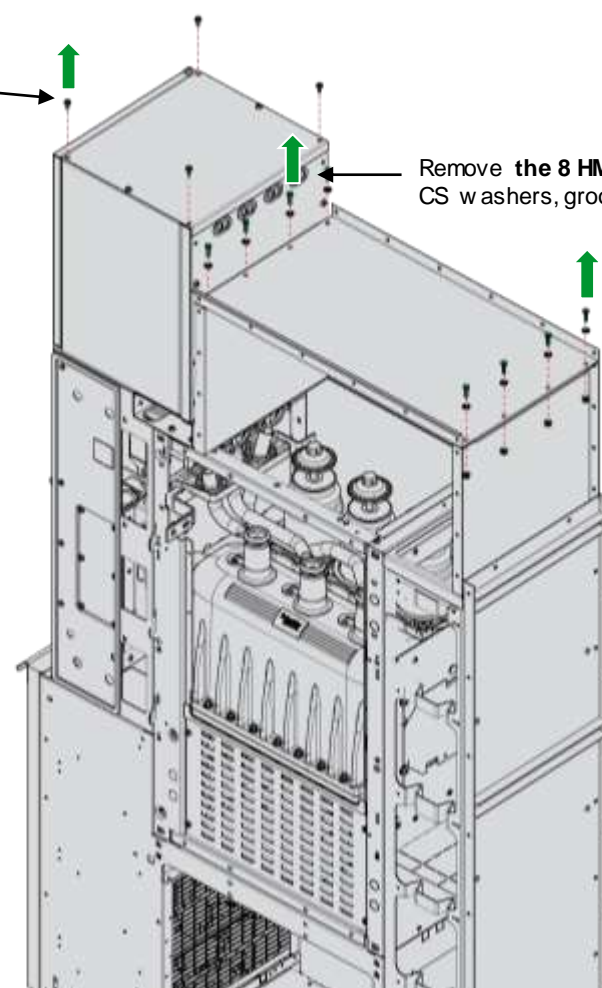

Remove the 8 HM6x16 screws, CS washers, grooved flanged nuts.*



All removed screws must be recycled



*If the roof is already assembled.



Supports assembly

Cabinet C – Bottom Exhaust

Cabinet C – Top Exhaust

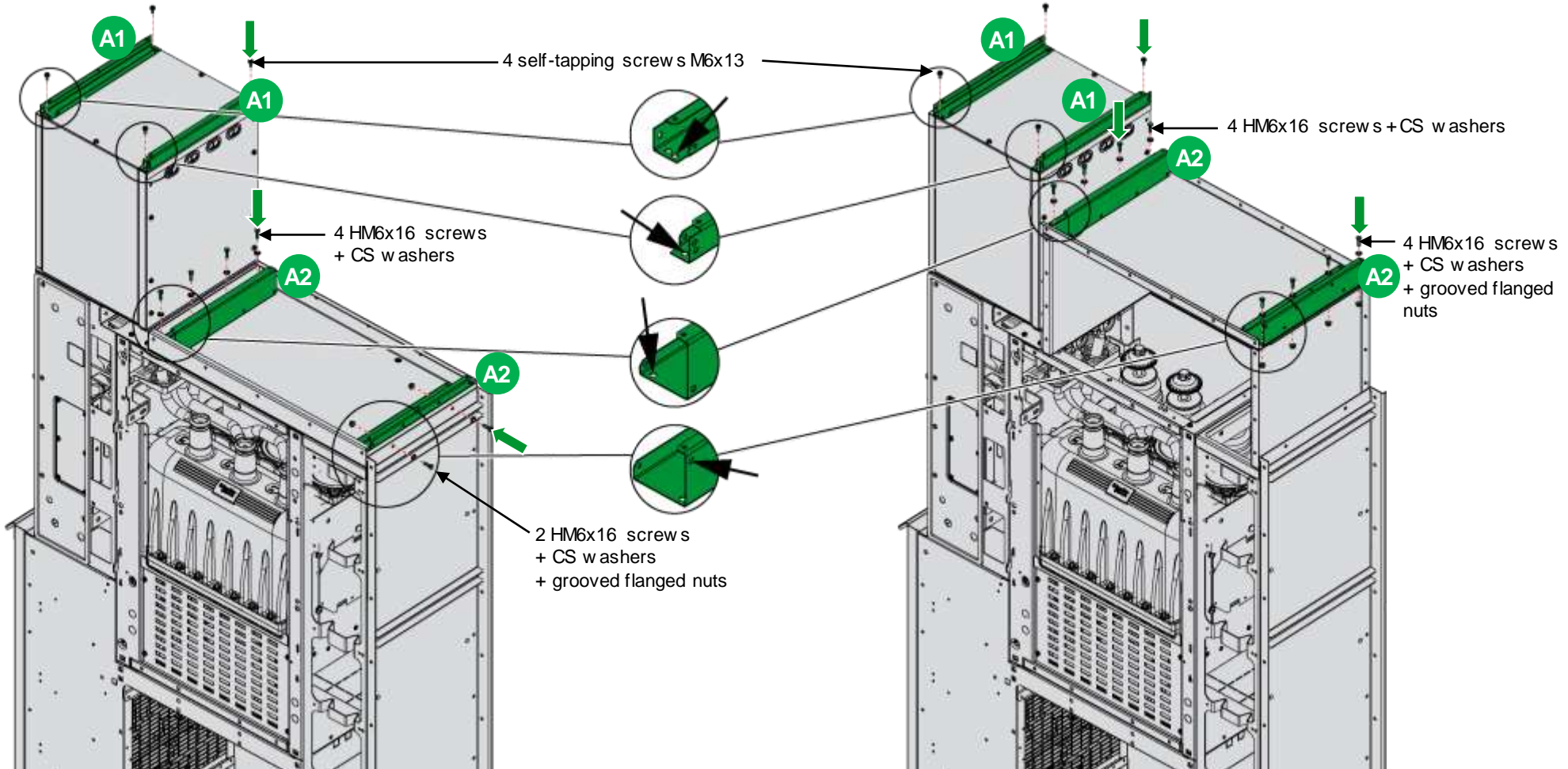



Assembly of horizontal roofs

Cabinet C – Bottom Exhaust

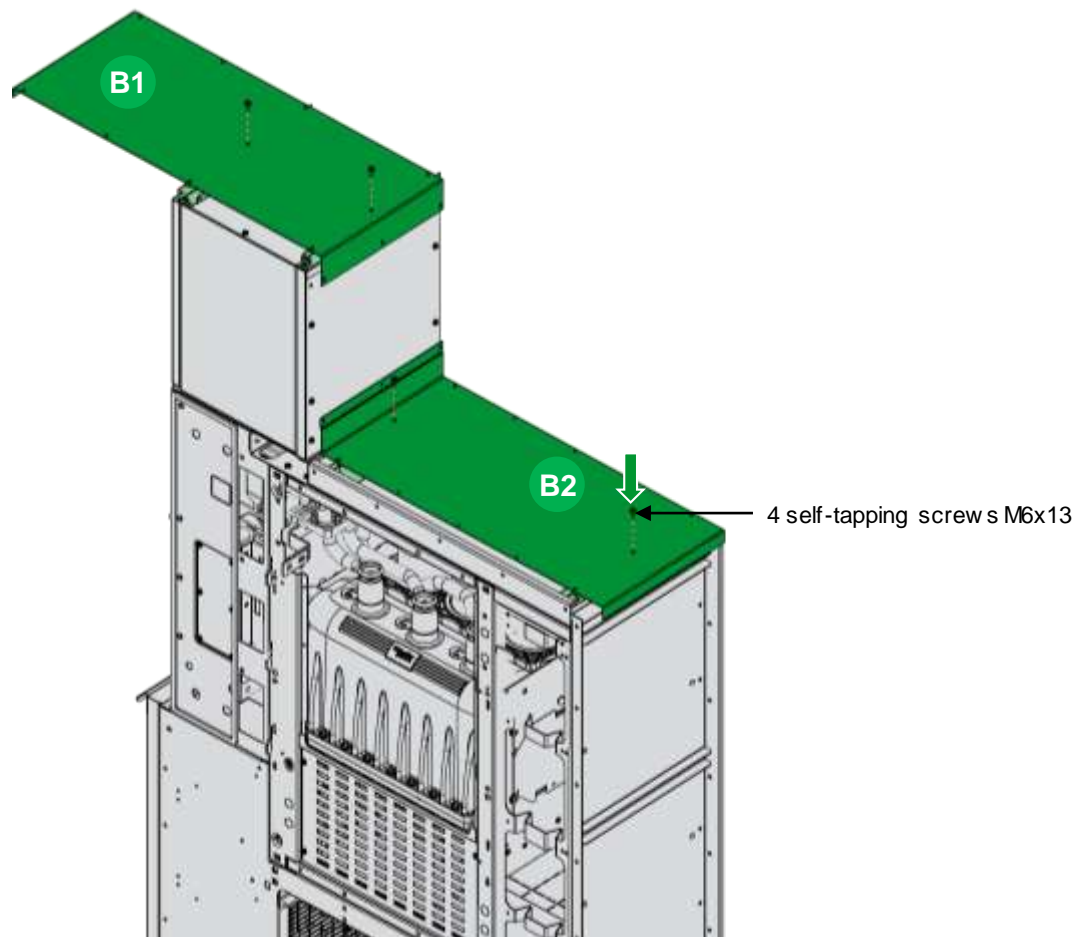

Cabinet C – Top Exhaust

Assembly order to respect ① + ②

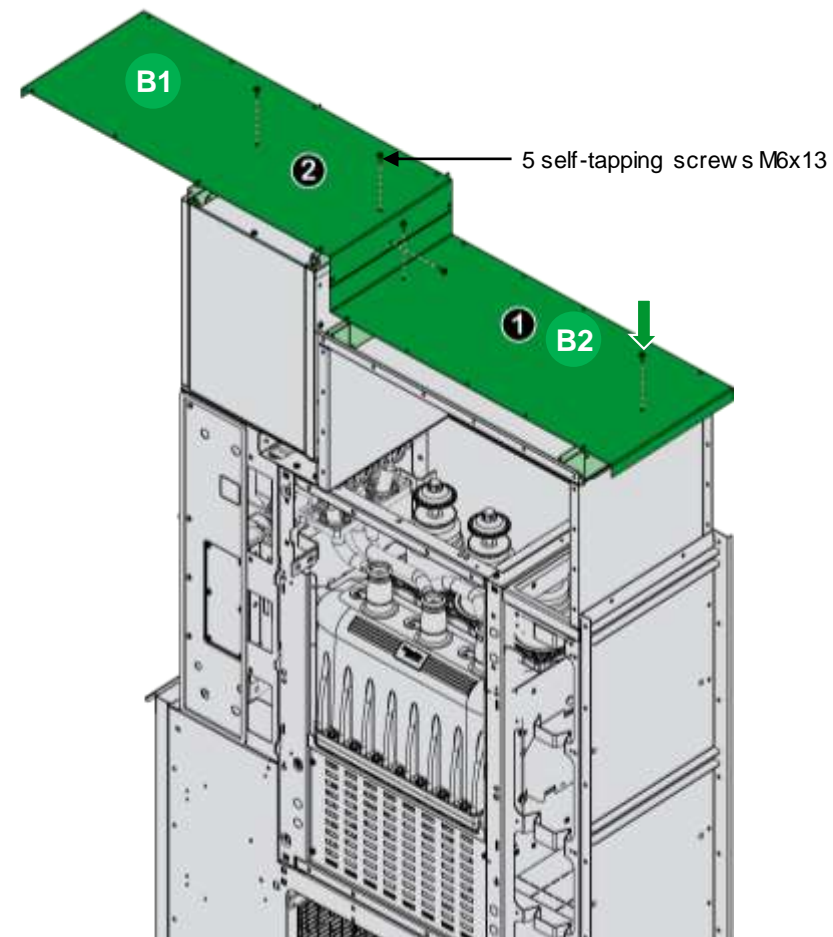



Preliminary step

S0

Preparation before assembly

S1

Assembly

S2

Assembly of vertical roof (1 or more depending of configurations)

Cabinet C – Bottom Exhaust

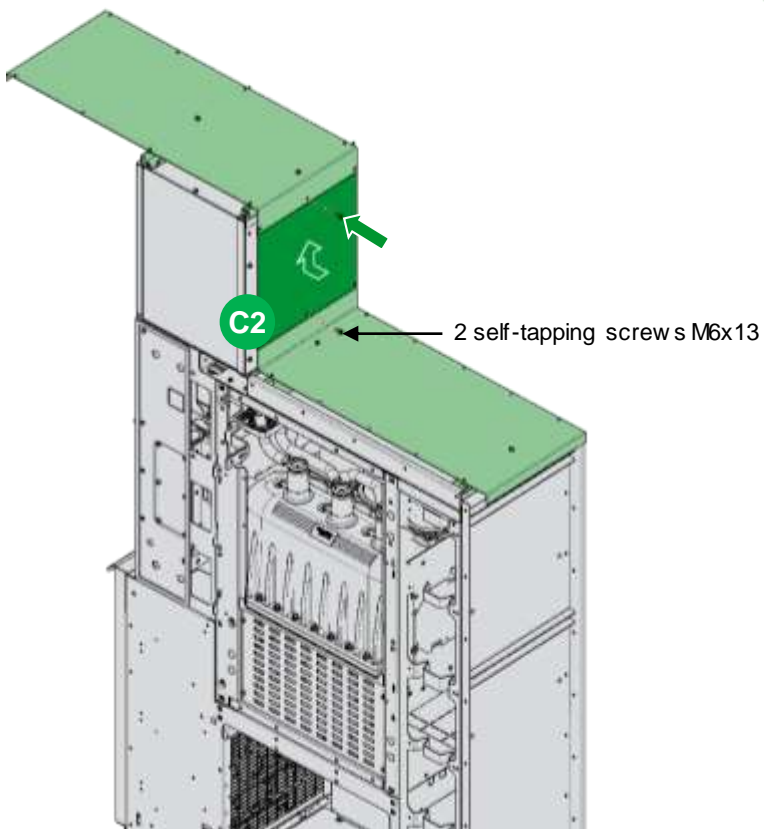

Cabinet C-MAX – Bottom Exhaust

Assembly order to respect 1 + 2

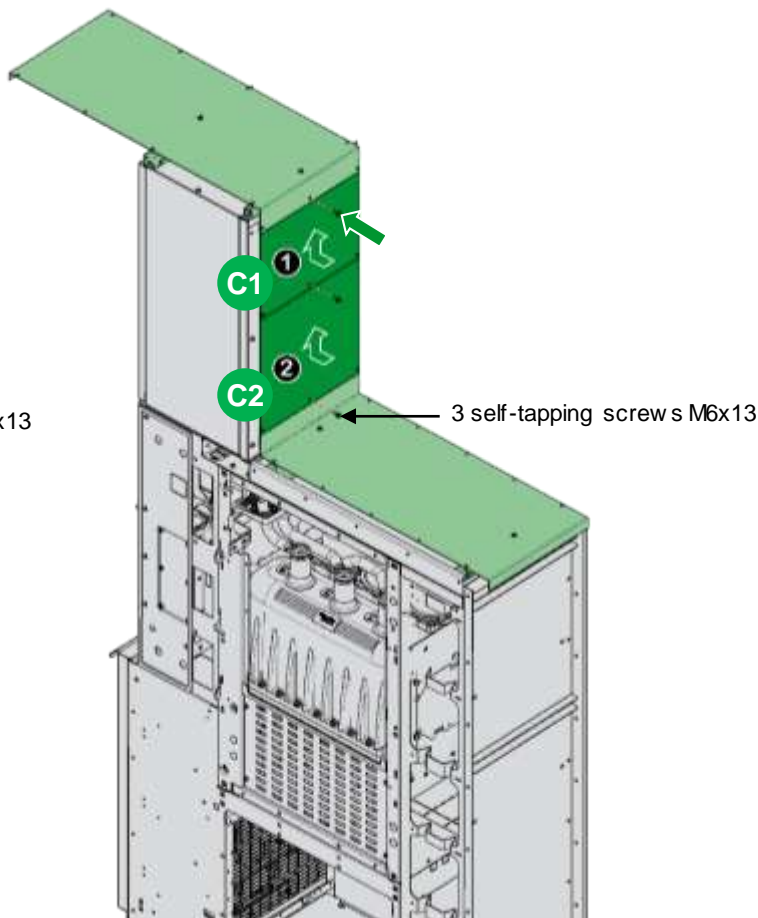

Cabinet C-MAX – Top Exhaust

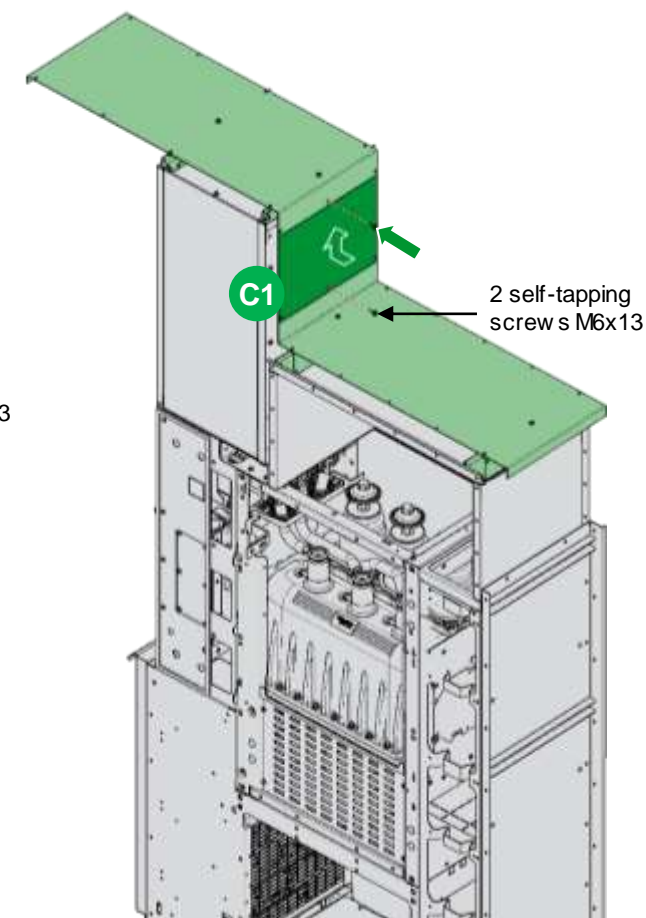



Preliminary step

S0

Preparation before assembly

S1

Assembly

S2

Assembly of the end bands

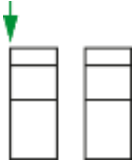

Cabinet C – Bottom Exhaust

Assembly order to respect 1 + 2 + 3

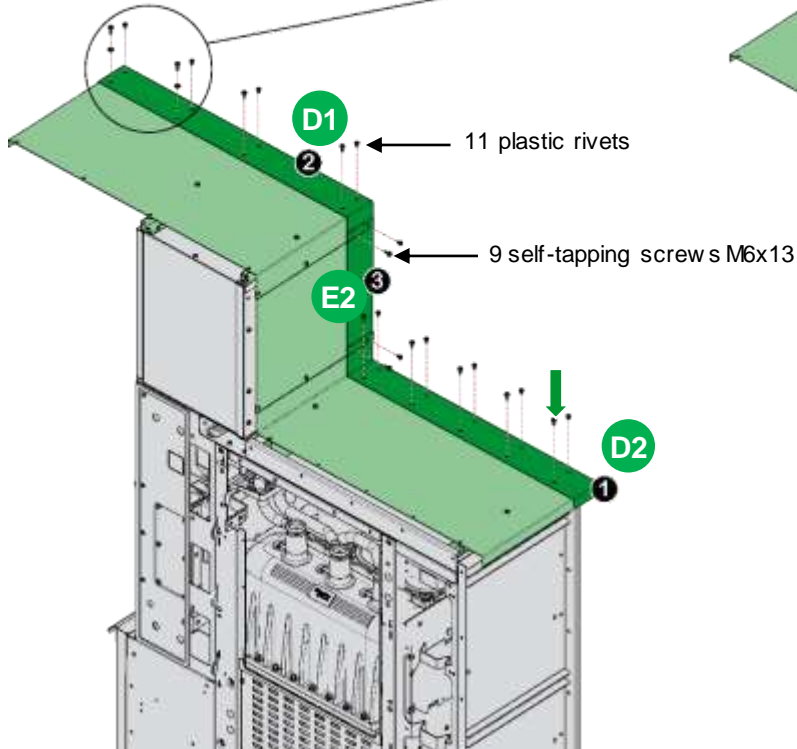

Cabinet C-MAX – Bottom Exhaust

Assembly order to respect

1 + 2 + 3 + 4

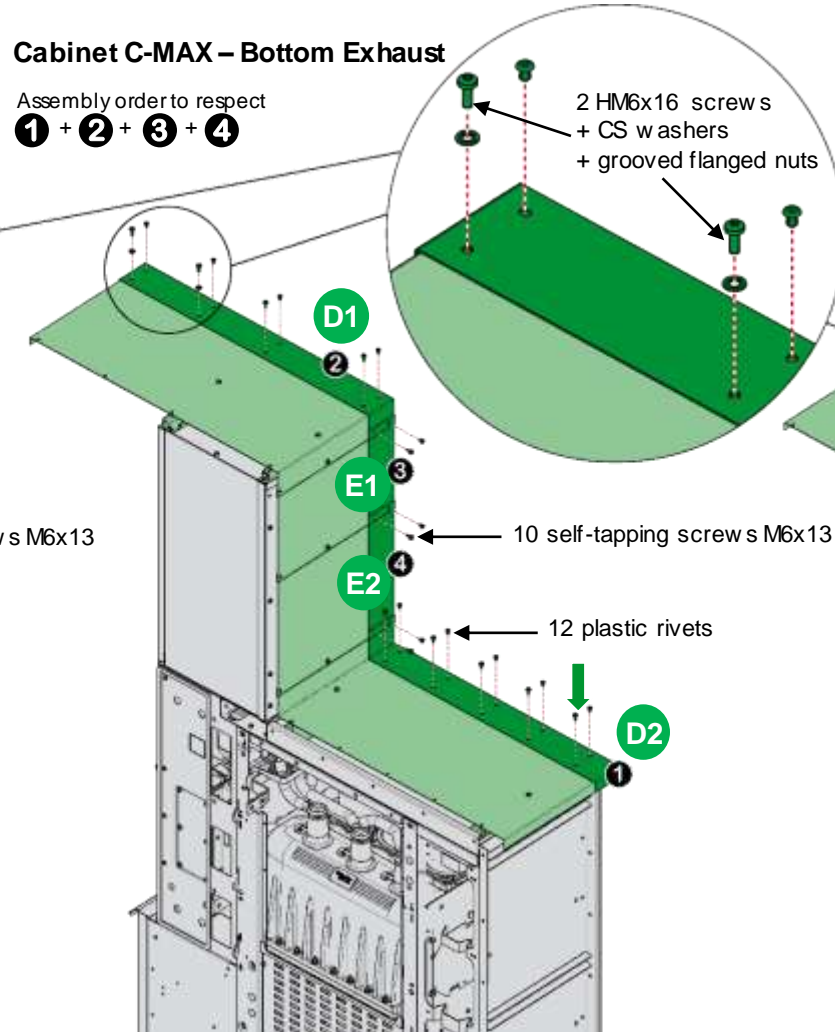

Cabinet C-MAX – Top Exhaust

Assembly order to respect 1 + 2

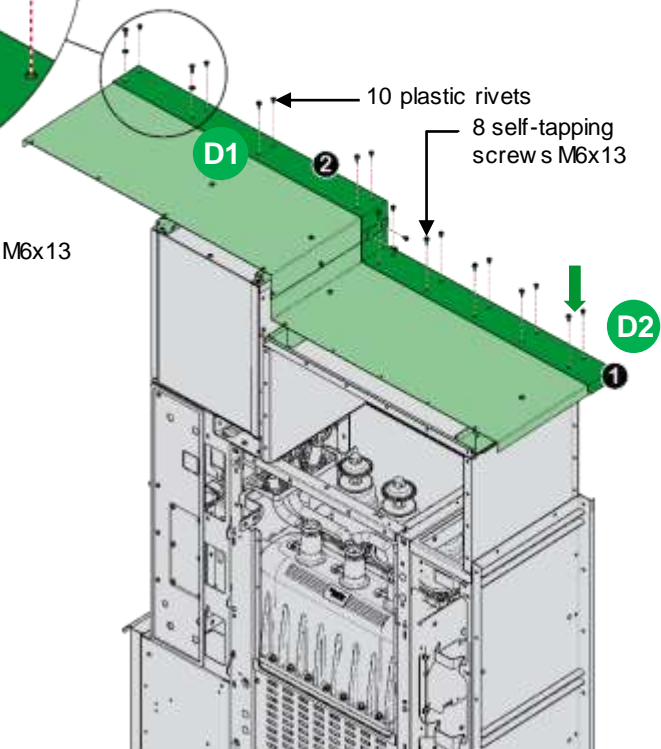



Preliminary step

S0

Preparation before assembly

S1

Assembly

S2

Continuity of switchboard

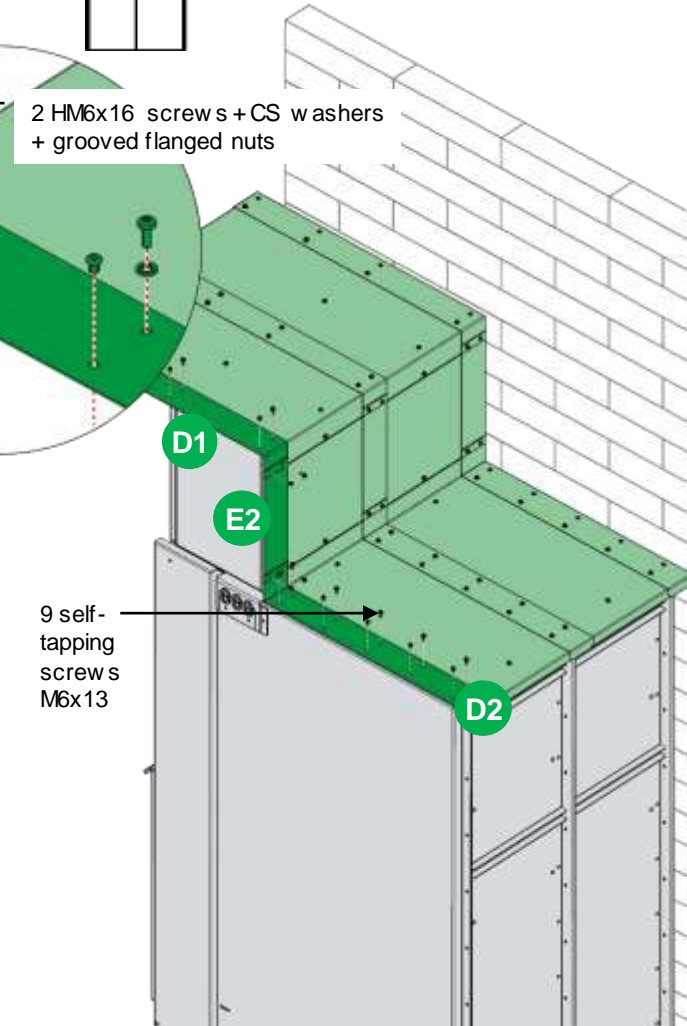
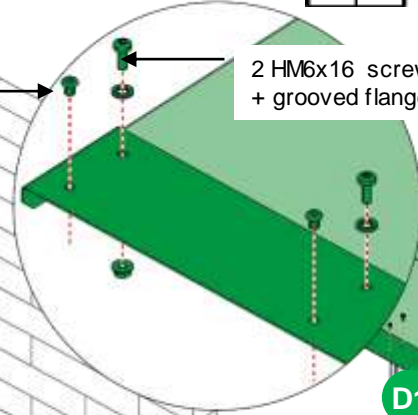
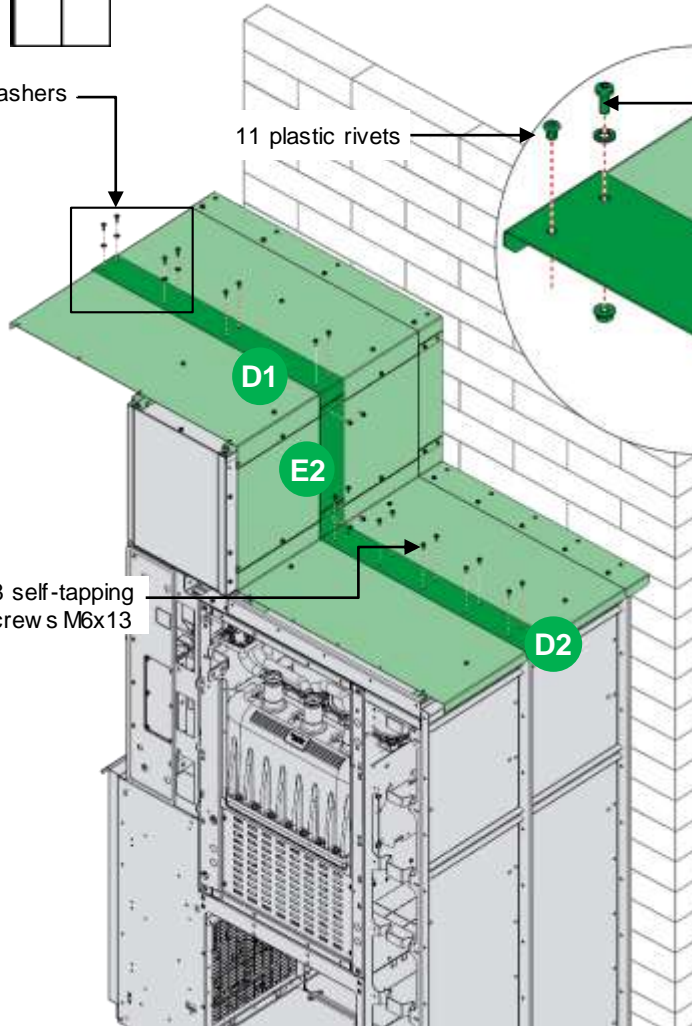
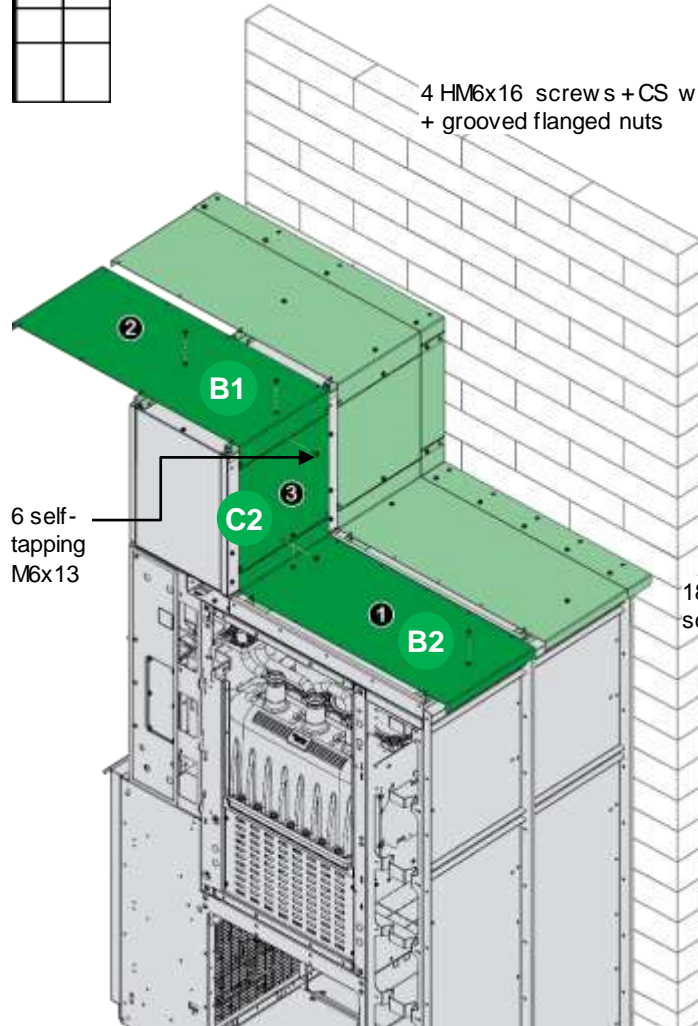
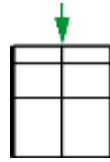
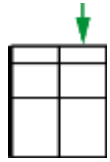

Group Schneider Electric service centers are there for:

*Engineering and technical
Assistance
Start-up
Training
Preventive and corrective maintenance
Adaptation work
Spare parts*

Call your sales representative who will put you in touch with your nearest group Schneider Electric service centre.

*En raison de l'évolution des normes et du matériel, les caractéristiques indiquées par le texte et les images de ce document ne nous engageant qu'après confirmation par nos services.
As standards, specifications and designs change from time to time, please ask for confirmation of the information given in this publication.*

Schneider Electric

35, rue Joseph Monier
CS 30323
F - 92506 Rueil Malmaison Cedex (France)
Tél. : +33 (0)1 41 29 70 00
<http://www.schneider-electric.com>