

PacDrive™

SM-Motor

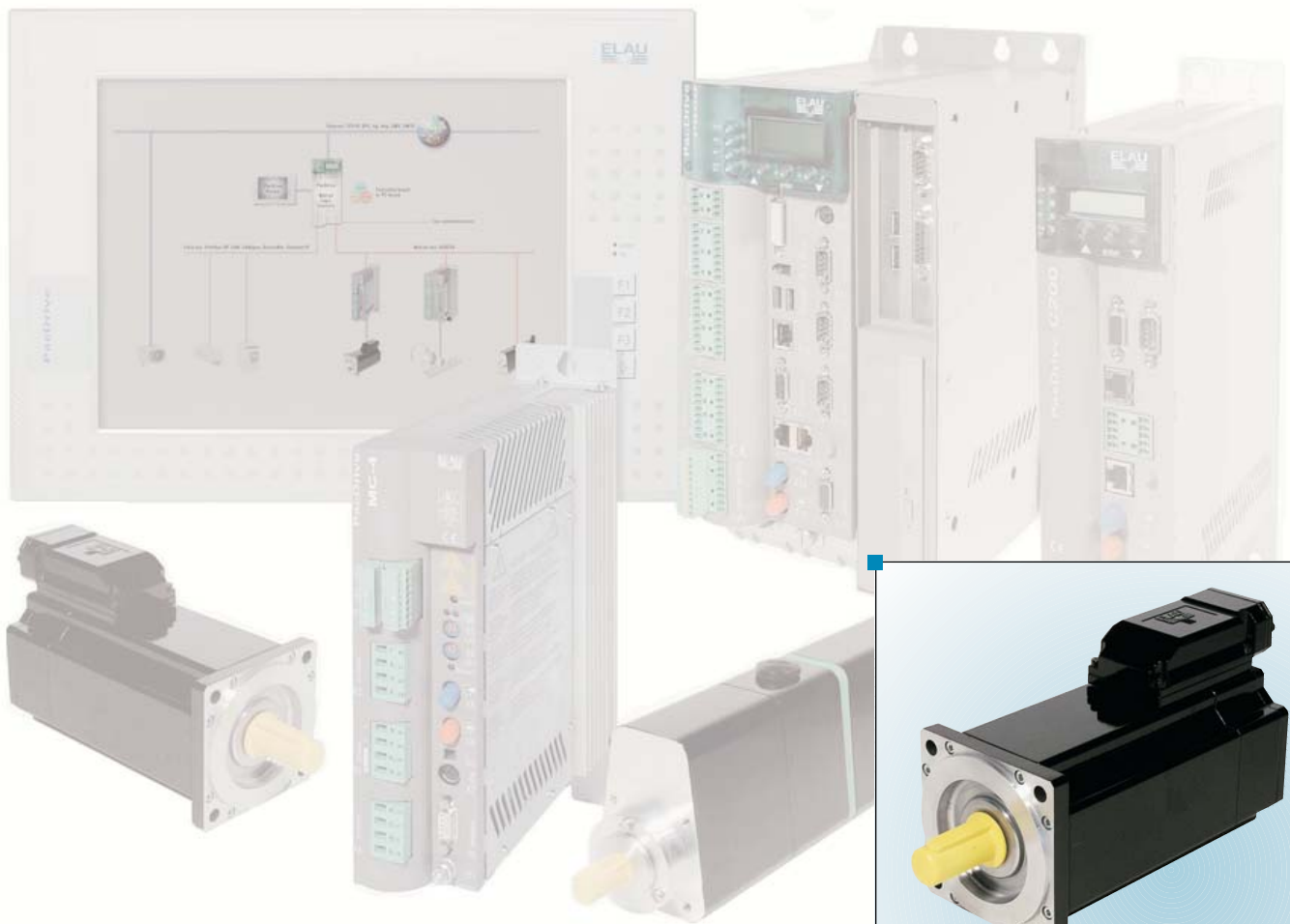

Imprint

© All rights reserved to ELAU AG, also in case of patent right applications.

No part of this documentation and the related software and firm-ware may be reproduced, rewritten, stored on a retrieval system, transmitted or translated into any other language or computer language without the express written consent of ELAU AG.

Any possible measure was taken to ensure the that this product documentation is complete and correct. However, since hardware and software are continuously improved, ELAU makes no representations or warranties with respect to the contents of this product documentation.

Trademarks

PacDrive is a registered trademark of ELAU AG.

All other trademarks mentioned are the exclusive property of their manufacturers.

ELAU AG
Dillberg 12
D-97828 Marktheidenfeld
Phone: 09391/606-0
Fax: 09391/606-300
eMail: info@elau.de
Internet: www.elau.de

ELAU Inc.
165 E. Commerce Drive
Schaumburg, IL 60173 - USA
Phone: +1 847 490 4270
Fax: +1 847 490 4206
e-mail: info@elau.com
Internet: www.elau.com

Contents

1	On this manual	5
1.1	Introduction	5
1.2	Symbols, Signs and Forms of Depiction	6
2	General Safety Notes	7
2.1	Basics	7
2.2	Depiction of Safety Notes	8
2.3	Use as Directed	9
2.4	Selection and Qualification of Staff	10
2.5	Residual Risks	10
2.5.1	Installation and Handling	10
2.5.2	Protection against Touching Electrical Parts	11
2.5.3	Potentially Dangerous Movements	12
3	Overview	13
3.1	In General	13
3.2	Features of the servo motors	13
3.3	Versions	14
4	Transportation, Storage, Unpacking	15
4.1	Transportation	15
4.2	Storage	15
4.3	Unpacking	16
4.3.1	Modified connections	17
5	Maintenance	19
5.1	Spare Parts, Components	19
5.2	Repair	20
5.3	Service Addresses	20
5.4	Exchanging Units	21
5.5	Cleaning	24
5.6	EMC Rules	25
5.7	Commissioning	27
5.8	PacDrive SM Motor with Barrier Pressure System	28
5.9	Configuration / Programming / Diagnosis	29
5.10	Order Numbers	30
5.10.1	SM Motor	30
5.10.2	SM Motor	31

5.10.3	Cables	35
5.10.4	Connector Sets	36
6	Technical Data	37
6.1	General Technical Data	37
6.1.1	Definitions and Physical Correlations	38
6.1.2	Ambient conditions, approbations	43
6.1.3	Protection class	45
6.1.4	Motor shaft and bearing	46
6.1.5	Encoders	48
6.1.6	Holding brake (optional)	51
6.1.7	Surface Ventilation (optional)	54
6.1.8	Technical Data in Detail	55
6.1.9	Torque-speed characteristics	59
6.2	Electrical Connections	69
6.2.1	X2 - motor	70
6.2.2	X3 - brake / motor temperature	71
6.2.3	X4 - encoder (SinCos)	72
6.2.4	X4 - encoder (Resolver)	73
6.3	Dimensions	74
6.3.1	SM-motor	74
6.3.2	SP-Gearbox	78
7	Appendix	83
7.1	Contact Addresses	83
7.2	Further Literature	84
7.3	Product Training	86
7.4	Declaration by the manufacturer	87
7.5	Modifications	88
7.6	Index	89
7.7	Form for Error Report	91

1 On this manual

1.1 Introduction

Before using the motor for the first time, you should familiarize yourself with this operating manual.

In particular, observe the safety notes described in chapter 2.

Only persons who meet the criteria for "Selection and Qualification of Staff" (see chapter 2.4) are allowed to work on the motors.

One copy of this manual has to be available for staff working on the motors with access at any time.

This manual is to help you use the motor safely and expertly and to use it as directed.

Observe this manual. This will help to avoid risks, reduce repair costs and down times and increase the lifetime and reliability of the products.

You also need to observe the valid rules for the prevention of accidents and for environmental protection in the country and place where the device is used.

1.2 Symbols, Signs and Forms of Depiction

The following symbols and signs are used in this document:



Depiction	Meaning
■	First level enumeration sign.
–	Second level enumeration sign.
▶	Action symbol: The text following this symbol includes an instruction for action. Execute the instruction actions in the given order, from top to bottom.
✓	Result symbol: The text following this symbol contains the result of an action.
<i>Italics</i>	If the describing text contains special terms (e.g. parameters) these are written in italics.
Serif font	If the manual contains program code, this is marked by Serif font.
	Information symbol: This symbol marks notes and useful tips for using the product.
	Warning sign: Safety notes can be found in the relevant places. They are marked by this symbol.

Table 1-1: Symbols, signs and forms of depiction

2 General Safety Notes

This chapter contains general requirements for working safely. Every person using ELAU components or working on ELAU components has to read and observe these general safety notes.

If activities involve a residual risk, you will find a clear note in the respective places. The note describes the risk that may occur and preventive measures to avoid that risk.

2.1 Basics

The motor is built according to the state of technology and generally accepted safety rules. Nevertheless, its use may cause a risk to life and limb or material damage if:

- you do not use the motor as directed
- work on the motor is not done by experts or instructed staff
- you inexpertly alter or modify the motor
- you fail to test the protective measures in place after installation, commissioning or servicing
- you do not observe the safety notes and regulations.

Only operate the motor in perfect technical condition, as directed, with regard to safety and risks and observe this manual.

The flawless and safe operation of the motor requires appropriate transport, storage, mounting and installation as well as careful maintenance.

In case of any circumstances that impair the safety and cause changes in the operating behavior, immediately bring the motor to a stop and inform the service staff in charge.

In addition to this manual, observe

- the prohibiting, warning and mandatory signs on the motor, the connected components and in the switching cabinet
- the relevant laws and regulations
- the operating manuals of the other components
- the universally valid local and national rules for safety and the prevention of accidents.

2.2 Depiction of Safety Notes

Risk categories

The safety notes in this manual are grouped into different risk categories. The table below shows which risk and possible consequences the symbol (pictograph) and the signal words indicate.

Pictograph	Signal word	Definition
	DANGER!	Indicates an immediately dangerous situation that will result in death or very serious injuries if the safety rules are not observed.
	WARNING!	Indicates a possibly dangerous situation that can result in serious injuries or major material damage if the safety rules are not observed.
	CAUTION!	Indicates a possibly dangerous situation that might result in material damage if the safety rules are not observed.

Table 2-1: Risk categories

2.3 Use as Directed

The motor is designed as a drive component for installation in a machine or for combination with other components to form a machine/plant. The motor may only be used under the installation and operating conditions described in this documentation. You must use the accessories and ancillary parts (components, cables, etc.) mentioned in the documentation. You must not use any foreign objects or components that are not explicitly approved by ELAU.

Use as directed also means that you

- observe the operating manuals and other documentations (see appendix)
- observe the inspection and service instructions.

Misusage The operating conditions at the place where the device is used must be checked on the basis of the given technical data (performance information and ambient conditions) and observed.

Commissioning is prohibited unless it is guaranteed that the applicable machine or plant in which the motor is installed is in its entirety compliant with the EC directive 98/37/EC (machine directive).

In addition, the following norms, directives and rules need to be observed:

- DIN EN 60204 Safety of machines:
Electrical equipment of machines.
- DIN EN 292 part 1 and part 2 Safety of machines:
Basics, general design rules.
- DIN EN 50178 Equipment of high-voltage plants with electronic operating means.
- EMC directive 89/336/EEC

2.4 Selection and Qualification of Staff

This manual is aimed exclusively at technically qualified staff with detailed knowledge in the field of automation technology.

Only qualified staff can recognize the significance of safety notes and implement them accordingly.

This manual is aimed in particular at design and application engineers in the fields of mechanical and electrical engineering, service and commissioning engineers.

Working on electrical equipment Work on electrical equipment must only be done by qualified electricians or by instructed staff supervised by an electrician according to the electrotechnical rules.

An electrician is a person who, due to his vocational training, know-how and experience as well as knowledge of the valid regulations, is able to:

- evaluate the work he is supposed to do
- identify potential risks
- implement suitable safety measures.

2.5 Residual Risks

The motors reflects the current technical standard. Nevertheless, there is a residual risk, since the motors work with electrical current and voltage. We minimized the health risk for people by means of appropriate construction and safety technology.

2.5.1 Installation and Handling



WARNING!

Risk of injury while handling the unit!

Risk of injury due to squeezing, cutting or hitting!

- Observe the universally valid construction and safety rules for handling and installation.
 - Use suitable installation and transport facilities and use them professionally. If necessary, use special tools.
 - Take precautions against squeezing.
 - If necessary, use suitable protective clothing (e.g. safety glasses, safety shoes, protective gloves).
 - Do not stay under pending loads.
 - Remove any leaking liquids from the floor immediately to avoid skidding.
-

2.5.2 Protection against Touching Electrical Parts

Touching parts carrying a voltage of 50 Volts or higher can be dangerous. When electric appliances are operated, certain parts of these appliances inevitably carry a dangerous voltage.



DANGER!

High voltage!

Life hazard!

- Observe the universally valid construction and safety rules for working on high-voltage units.
 - After installation, check the fixed connection of the earth conductor on all electric appliances according to the connection plan.
 - Operation, even for short-term measuring and test purposes, is only permitted with an earth conductor firmly connected to all electric components. Otherwise high voltages may occur on the casing.
 - Before accessing electric parts with voltages exceeding 50 Volts, disconnect the unit from mains or power supply and lock it out. After switching off, wait for at least 5 minutes before touching any components.
 - Do not touch electrical connections of the components while the unit is on.
 - Before switching on the unit, cover all voltage carrying parts to prevent accidental contact.
 - Provide for protection against indirect touching (DIN EN 50178 / 1998 section 5.3.2).
-



DANGER!

High leak current!

Life hazard!

- The leak current is greater than 3.5 mA. Therefore the units must have a firm connection to the power grid (according to DIN EN 50178 - equipment of high-voltage systems).
-

2.5.3 Potentially Dangerous Movements

There can be different causes for potentially dangerous movements:

- mistakes in wiring or cable connection
- software errors
- faulty components
- errors in measuring value and signal encoders
- operating mistakes

The monitoring functions in the driving components to a large extent rule out malfunction. For your protection, you must not rely on these functions alone. Until the controls installed become effective, you should anticipate faulty movement of the drive, which can vary depending on the kind of malfunction and the operating state. Personal protection must be ensured by additional measures superior to the plant. These are planned by the plant engineer with regard to the specific circumstances of the plant and after a risk and error analysis. The safety provisions of the plant are taken into account.



DANGER!

Potentially dangerous movements!

Life hazard, serious injury or material damage!

- No persons are allowed within the motion range of the machine. This is to be ensured by means of devices like protective fences, grids, covers or photoelectric barriers.
 - The fences and covers must be sufficiently strong to withstand the maximum possible motion energy.
 - The emergency stop switch must be located very close to the operator. Check the operation of the emergency stop before starting up the plant.
 - Secure against unintentional start by enabling the mains contactor of the drives via an emergency off circuit or by means of the function 'safe stop'.
 - Before accessing the danger zone, bring the drives to a safe stop.
 - To work on the plant, power must be turned off and locked out.
 - Avoid operating high-frequency, remote-control and radio devices in the vicinity of the plant's electronics and connecting wires. If the use of those devices is inevitable, check system and plant for possible malfunctions before first operation. In some cases a special EMC check may be necessary.
-

3 Overview

3.1 In General

The highly dynamic synchronous AC servo motors of ELAU's SM series are permanent field synchronous machines designed especially for highly dynamic positioning tasks.

The low moment of inertia compared with other AC servo motors in combination with the high overload tolerance not only guarantees excellent acceleration values, but also reduces energy consumption and stray heat of the motor.

The torque is generated by the stator coil fed by a sinusoidal three-phase current system in combination with the magnetic field excited by the rotor magnets.

The generation of the rotary current system depends on the rotor position in the digital motor controller or the positioning motor controller.

For that purpose, the rotor position is monitored by a resolver. Thanks to that principle, the drives are extremely robust and work without wearing down.

3.2 Features of the servo motors

The SM motors are characterised by the following features:

- High equipment dependability
- Maintenance-free operation
- Overload protection (by motor temperature monitoring)
- High performance data
- High dynamics
- High overload capacity
- Large torque area
- sinusoidal EMK
- High volt technique = low currents
- Low mass-moment of inertia
- Motor link and feedback system over connection box
- Simple and fast commissioning (by electronic vehicle identification plate in the SinCos encoder)

3.3 Versions

Motor feedback

- SinCos encoder singleturn or
- SinCos encoder multiturn or
- Resolver feedback

Holding brake

- without brake (standard) or
- with brake (option) to hold axis when in vertical position or when plant is powerless.

Shaft

- Smooth shaft (standard) or
- Shaft with feather groove (option)

Miscellaneous

- The SM motors also with ventilation and gear reducer options.

4 Transportation, Storage, Unpacking

4.1 Transportation

- ▶ Avoid shocks.
- ▶ Immediately check units for transport damage and inform your transport company, if necessary.

4.2 Storage

- ▶ Store units in a clean, dry place.

Storage conditions:

- air temperature between - 25 °C and + 70 °C.
- temperature fluctuations max. 30 K per hour.

4.3 Unpacking

- ▶ Check whether the delivery is complete.
- ▶ Check all units for transport damage.

Type plate

The type plate contains all necessary motor information:

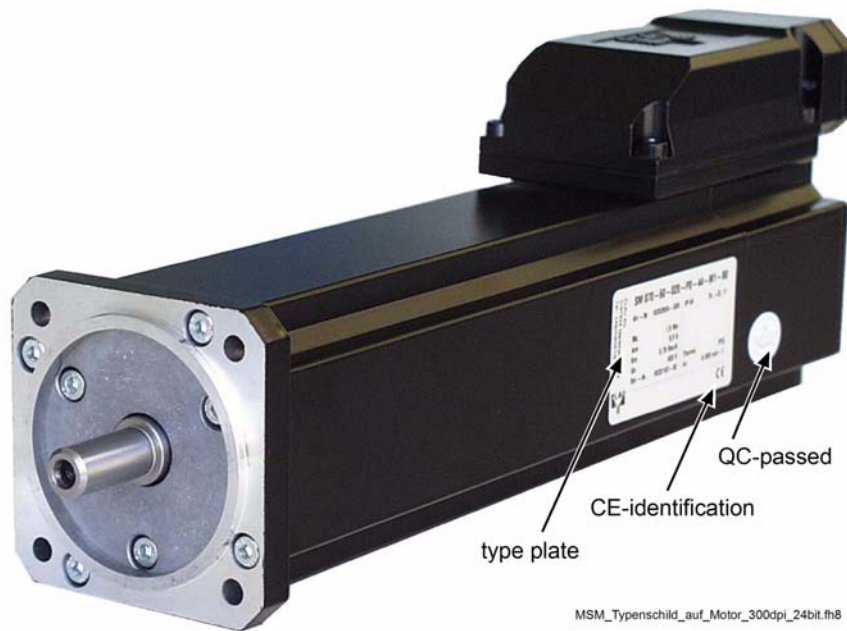

MSM_Typenschild_auf_Motor_300dpi_24bit.fh8

Fig. 4-1: type plate at the SM motor

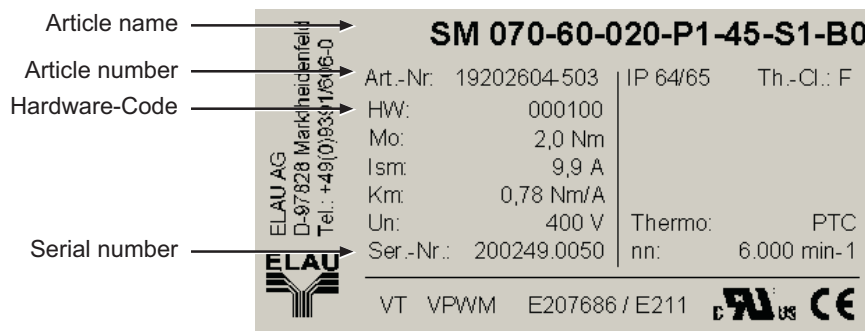

Fig. 4-2: type plate of a SM motor

4.3.1 Modified connections

Shield connection, connection technology and the installation of connection cables for SM Motors were improved and the terminal box adapted. Existing components, such as cables etc. can still be used. The new and previous versions of the motor are fully compatible.

In context with the improved connections, a hardware code was added on the type plate and the packaging of the motors.

Example: Type plate of an SM motor with modified connections.

ELAU AG D-97528 Marktheidenfeld Tel.: +49 (0)9391606-0 	SM 070-60-020-P1-45-S1-B0		Hardware-Code IP 64/65 Th.-Cl.: F	
	Art.-Nr:	19202604-503		
	HW:	000100		
	Mo:	2,0 Nm		
	Ism:	9,9 A		
	Km:	0,78 Nm/A		
Un:	400 V	Thermo:	PTC	
Ser.-Nr.:	200249.0050	nn:	6.000 min-1	
VT VPWM E207686 / E211				

Fig. 4-3: Type plate of an SM motor with modified connections

The following diagram shows how the cables are installed in the terminal box.

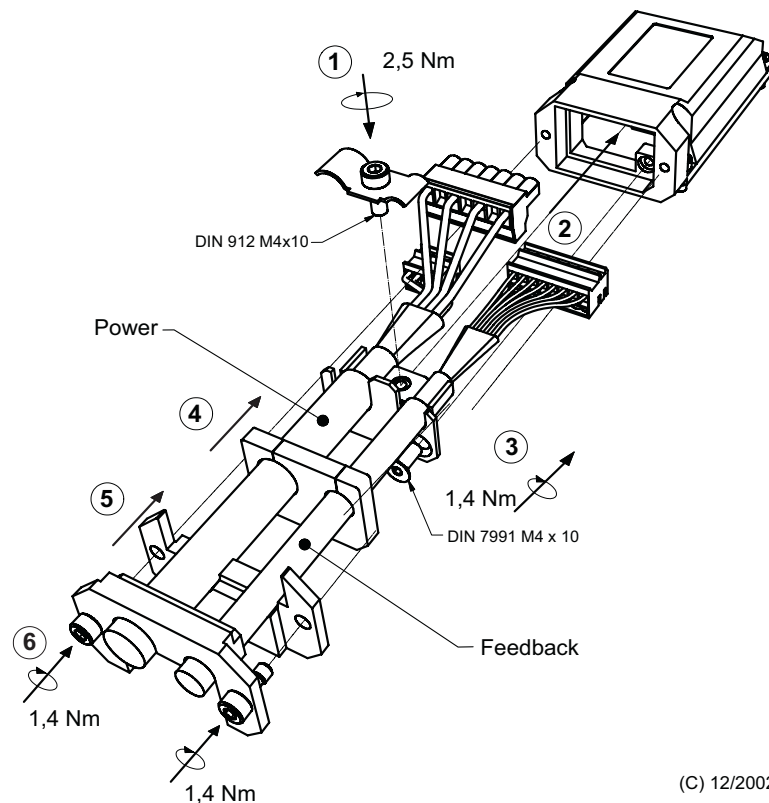

SM motor terminal box - cable installation



5 Maintenance

Recognizing and clearing an error quickly helps to keep the related production loss down to a minimum.

The diagnosis messages of the PacDrive™ system, which can be checked using EPAS, allows well directed and effective troubleshooting.

In case of an error, defective components can be exchanged with no problem. This ensures that the problem can be solved quickly and operation can be resumed soon. This work must be done by qualified maintenance staff only.

When returning a defective unit to the ELAU customer service, please complete the attached error report form.

5.1 Spare Parts, Components

Stock keeping of spare parts:

Keeping a stock of the essential components is a key prerequisite for the continuous functionality of the equipment.



ATTENTION!

Device compatibility!

Only units with identical hardware configuration and identical software version may be exchanged.

When ordering spare parts, please give the following data:

product name: e. g. SM 070-60-010-P0-44-M1-B0

article number: e. g. 19202602-509

You can find this information on the type plate of the motor (see Fig. 4-1) or in the configuration of your PacDrive™ M system.

5.2 Repair

By all means complete the attached error report form when returning defective components.

You can also make a photocopy of the error report form and use it as a fax message.



ATTENTION!

Electro static discharge!

Components may be damaged!

- Electronic parts may only be returned in the original or an equivalent packaging. In any case the components must be wrapped in an ESD packaging/foil. Otherwise warranty on equipment will be subject to termination.

5.3 Service Addresses

For ordering spare parts

ELAU AG
 Postfach 1255
 97821 Marktheidenfeld
 Phone: +49 (0) 93 91 / 606 - 0
 Fax: +49 (0) 93 91 / 606 - 300

For repair

Please send the components to be repaired or checked, along with the error report, to this address:

ELAU AG	
Abt. Kundendienst	
postal address:	house address:
Postfach 1255	Dillberg 12
97821 Marktheidenfeld	97828 Marktheidenfeld

Service team

Should you need to talk to a member of our service team or require on-site service, please contact:

ELAU AG
 Abt. Kundendienst / Applikation
 Postfach 1255
 97821 Marktheidenfeld
 Phone: +49 (0) 93 91 / 606 - 142
 Fax: +49 (0) 93 91 / 606 - 300

5.4 Exchanging Units

In addition to the notes below, please observe the information of the machine producer when exchanging the motor.



DANGER!

High Voltage!

Life Hazard!

- Before working on electrical units, disconnect from mains supply and secure against being switched on accidentally.
 - The drives must be standing safely because life-threatening voltages can occur on the motor cables of servo motors in generator operation.
 - Do not disconnect connector plugs while they are carrying voltage.
-



CAUTION!

Electro static discharge!

Components may be damaged!

- Only touch the boards by the edges. Do not touch any connections or components.
 - Before touching the boards, discharge any possible static charge. For this purpose, touch an earthed metal surface, e.g. the casing.
 - Do not place the boards on a metal surface.
 - Avoid the creation of electro static charge by the use of appropriate clothing, carpets and furniture and by moving the boards as little as possible.
-

Exchange motor



NOTE

If motors were stored longer than 2 years, the holding brake has to be resurfaced before you use it. See also " holding brake (option)" on page 52.

- ▶ Lift the main switch.
- ▶ Secure against accidental switch-on.



DANGER!

High voltage!
Life hazard!

- Connect or disconnect main power cable to motor only when no voltage is present on unit!



CAUTION!

Mechanical force!
Possible damage of the encoder system!

- When removing / applying a coupling off / to the motor shaft no impact may be executed on the motor shaft, to avoid damage of the encoder. Use suitable tools e. g. pullers.



WARNING!

Inadvertent movement of axes!
Danger of accident!

- With servo axes with indirect distance measurement system over the motor encoder the measure reference is lost with exchange of the engine!
The measure reference to the machine coordinate system therefore is to be reconstituted after the exchange!

- ▶ Exchange motor as described by the machine manufacturer.



CAUTION!

Insufficient shield connection/earthing!
Motor damage!

- In general operate motor only with tightly screwed connector box.

Exchange cable

- ▶ Lift the main switch
- ▶ Secure against accidental switch-on



DANGER!

High voltage!

Life hazard!

- Separate or join performance plug connectors of the cables only in status without tension of the system!
 - Join performance plug connectors only with dry and clean putting pages!
 - If no finished cables produced by ELAU are used, check allocation of new cables for agreement with the connection diagram of the machine manufacturer!
-

- ▶ Exchange the cables considering the specification of the machine manufacturer.

5.5 Cleaning

If installed appropriately, the devices are to a large extent maintenance-free.



CAUTION!

Penetration of liquid due to inexpert cleaning!

Motor damage!

- If the motor is cleaned with a high-pressure cleaner, liquid may penetrate into the motor casing. Use cleaning methods compliant with the protection type of the motor.
-

5.6 EMC Rules

To control and regulate motors, the mains voltage is stored in the DC-circuit of the MC-4 MotorController by means of rectification. This stored energy is fed to the motor by deliberately switching on and off six semiconductor switches. The steep rise and fall of the voltage puts high demands on the insulation strength of the motor winding. Another essential aspect to be considered is the Electro Magnetic Compatibility (EMC) with other system components. The flank steepness of the clocked voltage generates harmonic oscillations of great intensity, up into the high-frequency range.

Therefore observe the following EMC rules:

- Choose the earthing option with the lowest possible ohm rate (e.g. unpainted mounting board of the switching cabinet) for installation.
- Contact the largest possible surface (skin effect). If necessary, remove existing paint to achieve large-surface contact.
- From the Central Earthing Point (CEP), lay earthing wires to the respective connections in a star structure. Earthing circuits are not admissible and can cause unnecessary distortions.
- Use shielded cables only.
- Only large-surface shield transitions are admissible.
- Shields must not be contacted via pin contacts of connector plugs.
- By all means observe the switching proposals.
- Cut motor cables to minimum length.
- Do not lay cable loops inside the switching cabinet.



CAUTION!

Electromagnetic fields!

Disturbances or failure of the system possible!

With the installation the following rules must be considered, in order to exclude consequences of excessive disturbance effects as far as possible.

- In connection with electronic controls, no inductive loads whatsoever must be switched without suitable interference elimination.
 - For DC operation, suitable interference elimination can be achieved by arranging recovery diodes. For AC operation, commercially available erasing elements matching the connector type can be used.
 - Only the interference elimination element mounted immediately at the point of inductivity serves this purpose. In any other case, the switching pulse may even emit increased interference via the interference elimination elements. It is much easier to avoid sources of interference in the first place, than to eliminate the effects of existing interference.
 - In no case must the contacts switching unshielded inductive loads be arranged in the same room as the MC-4 MotorController; the same goes for cables carrying unshielded, switched inductivity and cables running parallel to them. The control must be separated from such „distorters“ by a Faraday cage (own section in the switching cabinet).
-



CAUTION!

Electromagnetic fields!

Disturbances or failure of the system possible!

- Dependent on the MotorController/motor combination and the cable length, system filters or motor filters should be used where possible.
Please observe the project manuals of the MotorControllers (MC-4/PMC-2).
-

5.7 Commissioning

We urgently recommend using ELAU staff for initial commissioning. This should not only be done for warranty reasons; at the same time

- the equipment is controlled,
- the optimum configuration is determined,
- the operating staff are instructed.

How to proceed when commissioning:

- Unpack and check**
- ▶ Remove packaging.
 - ▶ Check devices for damage. Only undamaged devices may be put into operation.
 - ▶ Check shipment for completeness.
 - ▶ Check data using the type plates.

See also chapter Transportation, Storage, Unpacking.

- Installation**
- ▶ Observe requirements for the place of installation.
 - ▶ Observe requirements for protection type and EMC rules.
 - ▶ Install devices.

See also chapter Maintenance.

- Electrical connection**
- ▶ Connect devices, starting with the earth conductor.
 - ▶ Check if the clamps are tight and the required cable cross sections are correct,
 - ▶ Check the perfect execution of the shield, rule out short-circuits and interruptions.

See also chapter Technical Data und Maintenance.

- Check safety functions**
- ▶ Check thermo contact of the motor and/or PTC sensor.
 - ▶ Check function of the brake (if any).
 - ▶ Check EMERGENCY OFF chain and EMERGENCY OFF limit switch.

- Continue commissioning the plant**
- ▶ Continue commissioning the plant according to the operating manuals (packaging machine producer and MotorController).

5.8 PacDrive SM Motor with Barrier Pressure System

The optional barrier pressure system is used to operate the motor in ambient conditions with high demands on protection against intrusion of liquids.

In practice, different liquids with creeping rates different from water are used. Moreover, the pressure in the casing rises as the drive gets hot and falls as the drive cools off. Those pressure differences encourage the penetration of liquid

barrier pressure system Permanent, reliable protection against the penetration of liquids and gases is achieved if the casing is kept under a slight overpressure by means of an air barrier. The pressurized air used for that purpose must be dry and free from dust and oil. As the system is closed, air consumption is so low that it can be neglected.

Properties	Value	Remark
Pressure	0,1...0,3 bar	recommended
Pressure	0,4 bar	maximum
Operating condition	dust-free	by means of suitable microfilters
Operating conditions	oil-free	by means of suitable oil separators
relative Luftfeuchtigkeit	20...30 %	

Table 5-1: Operating conditions for the use of the barrier pressure system

Connection of the barrier pressure system The motor is supplied with air via a commercially available compressed air pipe (polyamide plastic pipe 4 x 0,75 mm). A thread M3 for the barrier pressure system is placed in the terminal box.

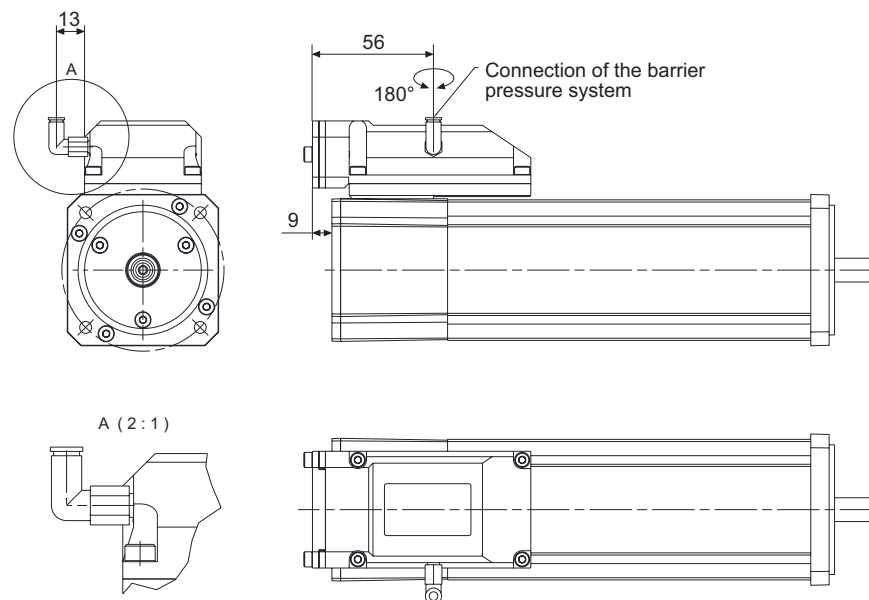

Fig. 5-1: Connection of the barrier pressure system at the SM-motor

5.9 Configuration / Programming / Diagnosis

The motors are adjusted by ELAU. The customer does not need to execute alignment.

The adjustment of the MotorControllers to the motors is to be inferred from the documentation of the respective MotorController.

See also the documentation of the MotorController.

Error diagnosis and monitoring of the operating conditions is executed into the ELAU controllers.

See programing reference manual for appropriate descriptions.

5.10 Order Numbers

5.10.1 SM Motor

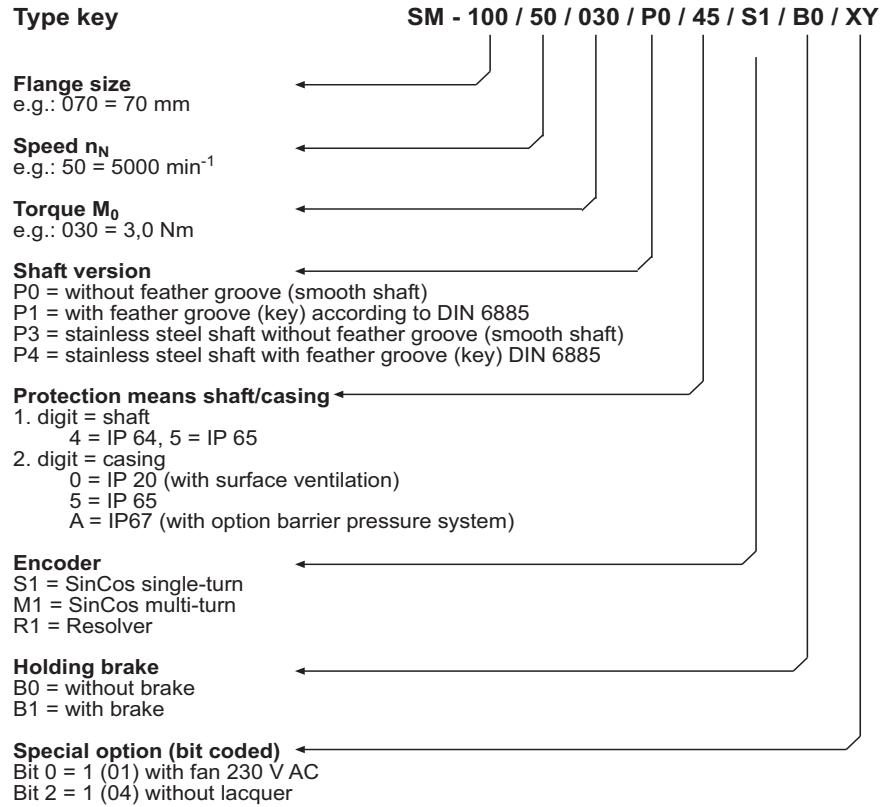

Fig. 5-2: Type key legend for SM motor

5.10.2 SM Motor

Basic Types

Order number	Product name	Explanations
19202602-xxx	SM-070/60/010/P0/45/S1/B0	SM-70
19202604-xxx	SM-070/60/020/P0/45/S1/B0	SM-70
19203501-xxx	SM-100/50/030/P0/45/S1/B0	SM-100
19203402-xxx	SM-100/40/050/P0/45/S1/B0	SM-100
19203304-xxx	SM-100/30/080/P0/45/S1/B0	SM-100
19203403-xxx	SM-100/40/080/P0/45/S1/B0	SM-100
19204301-xxx	SM-140/30/120/P0/45/S1/B0	SH-140
19204302-xxx	SM-140/30/210/P0/45/S1/B0	SH-140
19204303-xxx	SM-140/30/290/P0/45/S1/B0	SH-140
19204304-xxx	SM-140/30/370/P0/45/S1/B0	SH-140
19204202-xxx	SM-140/20/210/P0/45/S1/B0	SH-140

Table 5-2: Order numbers for SM Motor

Order number	Product name	Explanations
Shaft (standard) / IP64		
1920xxxx - 501	SM ... / .. / ... / P0 / 45 / S1 / B0	Singleturn
1920xxxx - 002	SM ... / .. / ... / P0 / 45 / S1 / B1	Singleturn, brake
1920xxxx - 503	SM ... / .. / ... / P1 / 45 / S1 / B0	Singleturn, shaft
1920xxxx - 004	SM ... / .. / ... / P1 / 45 / S1 / B1	Singleturn, brake, shaft
1920xxxx - 505	SM ... / .. / ... / P0 / 45 / R1 / B0	Resolver
1920xxxx - 006	SM ... / .. / ... / P0 / 45 / R1 / B1	Resolver, brake
1920xxxx - 507	SM ... / .. / ... / P1 / 45 / R1 / B0	Resolver, shaft
1920xxxx - 008	SM ... / .. / ... / P1 / 45 / R1 / B1	Resolver, shaft, brake
1920xxxx - 509	SM ... / .. / ... / P0 / 45 / M1 / B0	Multiturn
1920xxxx - 010	SM ... / .. / ... / P0 / 45 / M1 / B1	Multiturn, brake
1920xxxx - 511	SM ... / .. / ... / P1 / 45 / M1 / B0	Multiturn, shaft
1920xxxx - 012	SM ... / .. / ... / P1 / 45 / M1 / B1	Multiturn, shaft, brake
1920xxxx - 513	SM ... / .. / ... / P0 / 40 / S1 / B0 / 01	Singleturn, fan
1920xxxx - 014	SM ... / .. / ... / P0 / 40 / S1 / B1 / 01	Singleturn, brake, fan
1920xxxx - 515	SM ... / .. / ... / P1 / 40 / S1 / B0 / 01	Singleturn, shaft, fan
1920xxxx - 016	SM ... / .. / ... / P1 / 40 / S1 / B1 / 01	Singleturn, brake, shaft, fan
1920xxxx - 517	SM ... / .. / ... / P0 / 40 / R1 / B0 / 01	Resolver, fan
1920xxxx - 018	SM ... / .. / ... / P0 / 40 / R1 / B1 / 01	Resolver, brake, fan
1920xxxx - 519	SM ... / .. / ... / P1 / 40 / R1 / B0 / 01	Resolver, shaft, fan
1920xxxx - 020	SM ... / .. / ... / P1 / 40 / R1 / B1 / 01	Resolver, shaft, brake, fan
1920xxxx - 521	SM ... / .. / ... / P0 / 40 / M1 / B0 / 01	Multiturn, fan

Order number	Product name	Explanations
1920xxxx - 022	SM ... / .. / ... / P0 / 40 / M1 / B1 / 01	Multiturn, brake, fan
1920xxxx - 523	SM ... / .. / ... / P1 / 40 / M1 / B0 / 01	Multiturn, shaft, fan
1920xxxx - 024	SM ... / .. / ... / P1 / 40 / M1 / B1 / 01	Multiturn, shaft, brake, fan
Shaft (stainless steel) / IP64		
1920xxxx - 525	SM ... / .. / ... / P3 / 45 / S1 / B0	Singleturn
1920xxxx - 026	SM ... / .. / ... / P3 / 45 / S1 / B1	Singleturn, brake
1920xxxx - 527	SM ... / .. / ... / P4 / 45 / S1 / B0	Singleturn, shaft
1920xxxx - 028	SM ... / .. / ... / P4 / 45 / S1 / B1	Singleturn, brake, shaft
1920xxxx - 529	SM ... / .. / ... / P3 / 45 / R1 / B0	Resolver
1920xxxx - 030	SM ... / .. / ... / P3 / 45 / R1 / B1	Resolver, brake
1920xxxx - 531	SM ... / .. / ... / P4 / 45 / R1 / B0	Resolver, shaft
1920xxxx - 032	SM ... / .. / ... / P4 / 45 / R1 / B1	Resolver, shaft, brake
1920xxxx - 533	SM ... / .. / ... / P3 / 45 / M1 / B0	Multiturn
1920xxxx - 034	SM ... / .. / ... / P3 / 45 / M1 / B1	Multiturn, brake
1920xxxx - 535	SM ... / .. / ... / P4 / 45 / M1 / B0	Multiturn, shaft
1920xxxx - 036	SM ... / .. / ... / P4 / 45 / M1 / B1	Multiturn, shaft, brake
1920xxxx - 537	SM ... / .. / ... / P3 / 40 / S1 / B0 / 01	Singleturn, fan
1920xxxx - 038	SM ... / .. / ... / P3 / 40 / S1 / B1 / 01	Singleturn, brake, fan
1920xxxx - 539	SM ... / .. / ... / P4 / 40 / S1 / B0 / 01	Singleturn, shaft, fan
1920xxxx - 040	SM ... / .. / ... / P4 / 40 / S1 / B1 / 01	Singleturn, brake, shaft, fan
1920xxxx - 541	SM ... / .. / ... / P3 / 40 / R1 / B0 / 01	Resolver, fan
1920xxxx - 042	SM ... / .. / ... / P3 / 40 / R1 / B1 / 01	Resolver, brake, fan
1920xxxx - 543	SM ... / .. / ... / P4 / 40 / R1 / B0 / 01	Resolver, shaft, fan
1920xxxx - 044	SM ... / .. / ... / P4 / 40 / R1 / B1 / 01	Resolver, shaft, brake, fan
1920xxxx - 545	SM ... / .. / ... / P3 / 40 / M1 / B0 / 01	Multiturn, fan
1920xxxx - 046	SM ... / .. / ... / P3 / 40 / M1 / B1 / 01	Multiturn, brake, fan
1920xxxx - 547	SM ... / .. / ... / P4 / 40 / M1 / B0 / 01	Multiturn, shaft, fan
1920xxxx - 048	SM ... / .. / ... / P4 / 40 / M1 / B1 / 01	Multiturn, shaft, brake, fan
Shaft (standard) / IP65		
1920xxxx - 549	SM ... / .. / ... / P0 / 55 / S1 / B0	Singleturn
1920xxxx - 050	SM ... / .. / ... / P0 / 55 / S1 / B1	Singleturn, brake
1920xxxx - 551	SM ... / .. / ... / P1 / 55 / S1 / B0	Singleturn, shaft
1920xxxx - 052	SM ... / .. / ... / P1 / 55 / S1 / B1	Singleturn, brake, shaft
1920xxxx - 553	SM ... / .. / ... / P0 / 55 / R1 / B0	Resolver
1920xxxx - 054	SM ... / .. / ... / P0 / 55 / R1 / B1	Resolver, brake
1920xxxx - 555	SM ... / .. / ... / P1 / 55 / R1 / B0	Resolver, shaft
1920xxxx - 056	SM ... / .. / ... / P1 / 55 / R1 / B1	Resolver, shaft, brake
1920xxxx - 557	SM ... / .. / ... / P0 / 55 / M1 / B0	Multiturn
1920xxxx - 058	SM ... / .. / ... / P0 / 55 / M1 / B1	Multiturn, brake
1920xxxx - 559	SM ... / .. / ... / P1 / 55 / M1 / B0	Multiturn, shaft

Order number	Product name	Explanations
1920xxxx - 060	SM ... / ... / ... / P1 / 55 / M1 / B1	Multiturn, shaft, brake
1920xxxx - 561	SM ... / ... / ... / P0 / 50 / S1 / B0 / 01	Singleturn, fan
1920xxxx - 062	SM ... / ... / ... / P0 / 50 / S1 / B1 / 01	Singleturn, brake, fan
1920xxxx - 563	SM ... / ... / ... / P1 / 50 / S1 / B0 / 01	Singleturn, shaft, fan
1920xxxx - 064	SM ... / ... / ... / P1 / 50 / S1 / B1 / 01	Singleturn, brake, shaft, fan
1920xxxx - 565	SM ... / ... / ... / P0 / 50 / R1 / B0 / 01	Resolver, fan
1920xxxx - 066	SM ... / ... / ... / P0 / 50 / R1 / B1 / 01	Resolver, brake, fan
1920xxxx - 567	SM ... / ... / ... / P1 / 50 / R1 / B0 / 01	Resolver, shaft, fan
1920xxxx - 068	SM ... / ... / ... / P1 / 50 / R1 / B1 / 01	Resolver, shaft, brake, fan
1920xxxx - 569	SM ... / ... / ... / P0 / 50 / M1 / B0 / 01	Multiturn, fan
1920xxxx - 070	SM ... / ... / ... / P0 / 50 / M1 / B1 / 01	Multiturn, brake, fan
1920xxxx - 571	SM ... / ... / ... / P1 / 50 / M1 / B0 / 01	Multiturn, shaft, fan
1920xxxx - 072	SM ... / ... / ... / P1 / 50 / M1 / B1 / 01	Multiturn, shaft, brake, fan
Shaft (stainless steel) / IP65		
1920xxxx - 573	SM ... / ... / ... / P3 / 55 / S1 / B0	Singleturn
1920xxxx - 074	SM ... / ... / ... / P3 / 55 / S1 / B1	Singleturn, brake
1920xxxx - 575	SM ... / ... / ... / P4 / 55 / S1 / B0	Singleturn, shaft
1920xxxx - 076	SM ... / ... / ... / P4 / 55 / S1 / B1	Singleturn, brake, shaft
1920xxxx - 577	SM ... / ... / ... / P3 / 55 / R1 / B0	Resolver
1920xxxx - 078	SM ... / ... / ... / P3 / 55 / R1 / B1	Resolver, brake
1920xxxx - 579	SM ... / ... / ... / P4 / 55 / R1 / B0	Resolver, shaft
1920xxxx - 080	SM ... / ... / ... / P4 / 55 / R1 / B1	Resolver, shaft, brake
1920xxxx - 581	SM ... / ... / ... / P3 / 55 / M1 / B0	Multiturn
1920xxxx - 082	SM ... / ... / ... / P3 / 55 / M1 / B1	Multiturn, brake
1920xxxx - 583	SM ... / ... / ... / P4 / 55 / M1 / B0	Multiturn, shaft
1920xxxx - 084	SM ... / ... / ... / P4 / 55 / M1 / B1	Multiturn, shaft, brake
1920xxxx - 585	SM ... / ... / ... / P3 / 50 / S1 / B0 / 01	Singleturn, fan
1920xxxx - 086	SM ... / ... / ... / P3 / 50 / S1 / B1 / 01	Singleturn, brake, fan
1920xxxx - 587	SM ... / ... / ... / P4 / 50 / S1 / B0 / 01	Singleturn, shaft, fan
1920xxxx - 088	SM ... / ... / ... / P4 / 50 / S1 / B1 / 01	Singleturn, brake, shaft, fan
1920xxxx - 589	SM ... / ... / ... / P3 / 50 / R1 / B0 / 01	Resolver, fan
1920xxxx - 090	SM ... / ... / ... / P3 / 50 / R1 / B1 / 01	Resolver, brake, fan
1920xxxx - 591	SM ... / ... / ... / P4 / 50 / R1 / B0 / 01	Resolver, shaft, fan
1920xxxx - 092	SM ... / ... / ... / P4 / 50 / R1 / B1 / 01	Resolver, shaft, brake, fan
1920xxxx - 593	SM ... / ... / ... / P3 / 50 / M1 / B0 / 01	Multiturn, fan
1920xxxx - 094	SM ... / ... / ... / P3 / 50 / M1 / B1 / 01	Multiturn, brake, fan
1920xxxx - 595	SM ... / ... / ... / P4 / 50 / M1 / B0 / 01	Multiturn, shaft, fan
1920xxxx - 096	SM ... / ... / ... / P4 / 50 / M1 / B1 / 01	Multiturn, shaft, brake, fan
Option barrier pressure system / IP67		
1920xxxx - 620	SM ... / ... / ... / P3 / 5A / M1 / B1	Multiturn, brake

Order number	Product name	Explanations
1920xxxx - 621	SM ... / .. / ... / P4 / 5A / M1 / B1	Multiturn, brake, shaft
1920xxxx - 622	SM ... / .. / ... / P0 / 5A / M1 / B1	Multiturn, brake
1920xxxx - 623	SM ... / .. / ... / P3 / 5A / M1 / B0	Multiturn
1920xxxx - 624	SM ... / .. / ... / P4 / 5A / M1 / B0	Multiturn, shaft

Table 5-3: Order numbers for SM motor

5.10.3 Cables

Motor Cables

Order number	Product name	Explanations
15 15 41 01	E-MO-067 UL cable 1.5 mm ²	SM-070/100 on MC-4 X4
15 15 41 21	E-MO-092 UL cable 1.5 mm ²	SM-140 on MC-4 X4
15 15 41 12	E-MO-082 UL cable 2.5 mm ²	SM-140/30/210/.. with fan on MC-4 / 22 A X4
15 15 41 17	E-MO-087 UL cable 2.5 mm ²	SM-140/30/290; SM-140/30/370 on MC-4 / 22 A X4
15 15 41 20	E-MO-091 UL cable 4 mm ²	SM-140/30/370/... with fan on MC-4 / 22 A X4 on MC-4 / 50 A X4
15 15 41 02	E-MO-068 CE cable 1.5 mm ²	SM-070/100 on MC-4 X4
15 15 41 07	E-MO-073 CE cable 1.5 mm ²	SM-140 on MC-4 X4
15 15 41 03	E-MO-069 CE cable 2.5 mm ²	SM-140/30/210/... with fan on MC-4 / 22 A X4
15 15 41 13	E-MO-083 CE cable 2.5 mm ²	SM-140/30/290; SM-140/30/370 on MC-4 / 22 A X4
15 15 41 14	E-MO-084 CE cable 4 mm ²	SM-140/30/370/... with fan on MC-4 / 22 A X4 on MC-4 / 50 A X4
15 15 41 04	E-MO-070 UL cable 1.5 mm ²	SM-070/100 on PMC-2
15 15 41 05	E-MO-071 CE cable 1.5 mm ²	SM-070/100 on PMC-2
15 15 41 08	E-MO-074 CE cable 1.5 mm ²	SM-140 on PMC-2
15 15 41 06	E-MO-072 CE cable 2.5 mm ²	SM-140 on PMC-2

Table 5-4: Order numbers for motor cables

Encoder Cables

Order number	Product name	Explanations
15 15 42 01	E-FB-060 UL cable	SM-070; SM-100 X4 on MC-4 X8
15 15 42 02	E-FB-061 CE cable	SM-070; SM-100 X4 on MC-4 X8
15 15 42 13-XXX	E-FB-069 SM/SIN	Ext.. motor side SM070/100
15 15 42 15	E-FB-071 UL cable	SM-140 X4 on MC-4 X8
15 15 42 17	E-FB-073 CE cable	SM-140 X4 on MC-4 X8
15 15 42 03	E-FB-062 CE cable	on PMC-2 X12 (SinCos)
15 15 42 04	E-FB-067 CE cable	on PMC-2 X6 (resolver)

Table 5-5: Order numbers for encoder cables

5.10.4 Connector Sets

Order number	Product name	Explanaction
15 15 44 01	Connector Set SM070/100	Connector motor cable compl.
15 15 44 02-001	Connector Set SM140 Type1	Connector motor cable compl. (up to SM140/30/210)
15 15 44 02-002	Connector Set SM140 Type2	Connector motor cable compl. (from SM140/30/290)
15 15 44 02-003	Connector Set SR-058	connector motor and feedback

Table 5-6: Order numbers for connector sets

6 Technical Data

6.1 General Technical Data

Designation	Description
Motor type	Rotary synchr. servomotor, permanently excited
Magnetic material	Neodymium-Iron-Boron (NdFeB)
Insulation system (according to DIN VDE 0530)	Heat class F (155 °C)
Mounting orientation (according to DIN 42 950)	IM B5, IM V1, IM V3
Protection class (according to EN 60529)	IP65, in IM V3 shaft sealing required IP67, with optional barrier pressure system
Cooling	Self-cooling, rated ambient temperature up to 40 °C
Coating Approvals	two component high solid epoxid resin coating USDA - Incidental food contact NFPA - Class A NSF Standard 61 - Potable water Color of coating, Ral 9005
Temperature monitoring	Three-code thermocontact (CPTC) in the stator coil, switching temperature 130 °C
Shaft end	Cylindrical shaft end according to DIN 748 without key way
Concentric accuracy, coaxiality, axial run (according to DIN 42 955)	Tolerance N (normal)
Balancing class (according to DIN ISO 1940)	G 2.5
Built-in measuring system	Resolver 2 polepairs
Connection system	Cylindrical Connectors (IP67) turnable

Table 6-1: General technical data

Options	Description
Keyed shaft	Keyed shaft according to DIN 6885 T1
Brake	Electromagnetic permanent-magnet holding brake
Shaft in stainless steel	Shaft in stainless steel with / without keyed shaft
Sealing Housing	Barrier pressure System (IP67)
Shaft Sealing	Viton radial shaft seal on the flange side
Cooling	air and water cooling (in preparation)
Measuring system	SKS36, SKM36 more feedbacksystems available on request

Table 6-2: General technical data (Options)

6.1.1 Definitions and Physical Correlations

Abbrev.	Unit	Definition
I_{0M}	[A]	standstill current of the motor effective value of the motor current at standstill torque M_0
I_{NM}	[A]	rated motor current effective value of the motor current at rated torque M_N
I_{SM}	[A]	peak motor current effective value of the motor current at peak torque M_{SM}
I_{NC}	[A]	rated current of MotorController rated controller current (permanent operation S1)
I_{SC}	[A]	peak current of the MotorController peak current of the controller for acceleration phases also effective value of the motor current at peak torque M_{SA} supplied for a short time by the drive combination
J_M	[kgcm ²]	rotor moment of inertia the rotor moment of inertia refers to a motor with resolver and without brake
J_{ges}	[kgcm ²]	moment of inertia total moment of inertia (motor and load)
K_M	[Nm/A]	torque constant of the motor ratio of standstill torque M_0 and standstill current I_{0M} (e.g. K_{M20} for 20°C).
m	[kg]	mass motor mass without brake and without fan
M_0	[Nm]	standstill torque of the motor permanent torque (100% ED) at speed n_0 . With an ambient temperature of 40 °C, an overtemperature of 60 °C occurs on the motor casing, depending on the thermal motor time constant
M_N	[Nm]	rated motor torque permanent torque (100% ED) at rated speed n_N . Due to the speed-related losses, it is less than M_0 . With an ambient temperature of 40 °C, an overtemperature of 60 °C occurs on the motor casing, depending on the thermal motor time constant
M_{S3}	[Nm]	torque for intermittent operation S3 = 25% ED
M_{SA}	[Nm]	peak motor torque of monitor in combination with Motor Controller
M_{SM}	[Nm]	peak motor torque maximum torque which a servo motor can deliver on the working shaft for a short time

Abbrev.	Unit	Definition
n_{NM}	[1/min]	rated motor speed speed that can be used at rated torque. Idling speed n_L and mechanical limit speed n_{limit} of the servo motor are higher
P_{NM}	[kW]	rated mechanical power rated mechanical power of the servo motor according to rated speed n_N and rated torque M_N .
P_{NA}	[kW]	rated motor power in combination with controller
P_{ECKM}	[kW]	fringe motor power (theoretical value) $P_{FRINGEM} = M_{0M} * n_N * \pi / 30$
R_W	[Ω]	resistance of a motor winding resistance of a motor winding between phase and neutral point (e.g. R_{W20} for a winding temperature of 20 °C).
L_W	[mH]	winding inductivity winding inductivity for a winding temperature of 20 °C
t_{bSM}	[ms]	acceleration time acceleration time of the motor without external torque from 0 to rated speed n_N with peak motor current I_{SM} .

Table 6-3: Physical definitions with units

physical correlations

Correlation between torque and current:

$$M = K_M \times I_{\text{eff}}$$

M in Nm

K_M in Nm/A

I_{eff} in A (effective value of the phase current)

Current:

$$I_{\text{eff}} = \frac{I_{\text{summit}}}{1,41}$$

I_{eff} and I_{summit} in A

Rated motor power:

$$P_{\text{NM}} = M_{\text{N}} \times n_{\text{N}} \times \frac{\pi}{30}$$

P_{NM} in Watt

M_{N} in Nm

n_{N} in rpm

Admissible working time in AB operation (S3) with a play duration of 15 minutes:

$$ED = \left(\frac{M_{\text{N}}}{M_{\text{S3}}} \right)^2 \times 100$$

ED in %

M_{N} and M_{S3} in Nm

Effective torque with changing loads:

$$M_{\text{eff}} < M_{\text{N}}$$

$$M_{\text{eff}} = \sqrt{\frac{M_1^2 \times t_1 + M_2^2 \times t_2 + \dots + M_n^2 \times t_n}{t_1 + t_2 + \dots + t_n}}$$

Velocity:

$$v = \frac{n \times 2 \times \pi}{60}$$

w in rad/sec

n in rpm

Acceleration moment:

$$M_b = I_{\text{total}} \times \left(\frac{w}{t_b} \right)$$

M_b in Nm

I_{ges} in kgm^2

w in rad/sec

t_b in sec (acceleration time)

Acceleration:

$$a = \frac{w}{t_b}$$

a in rad/sec^2

w in rad/sec

t_b in sec

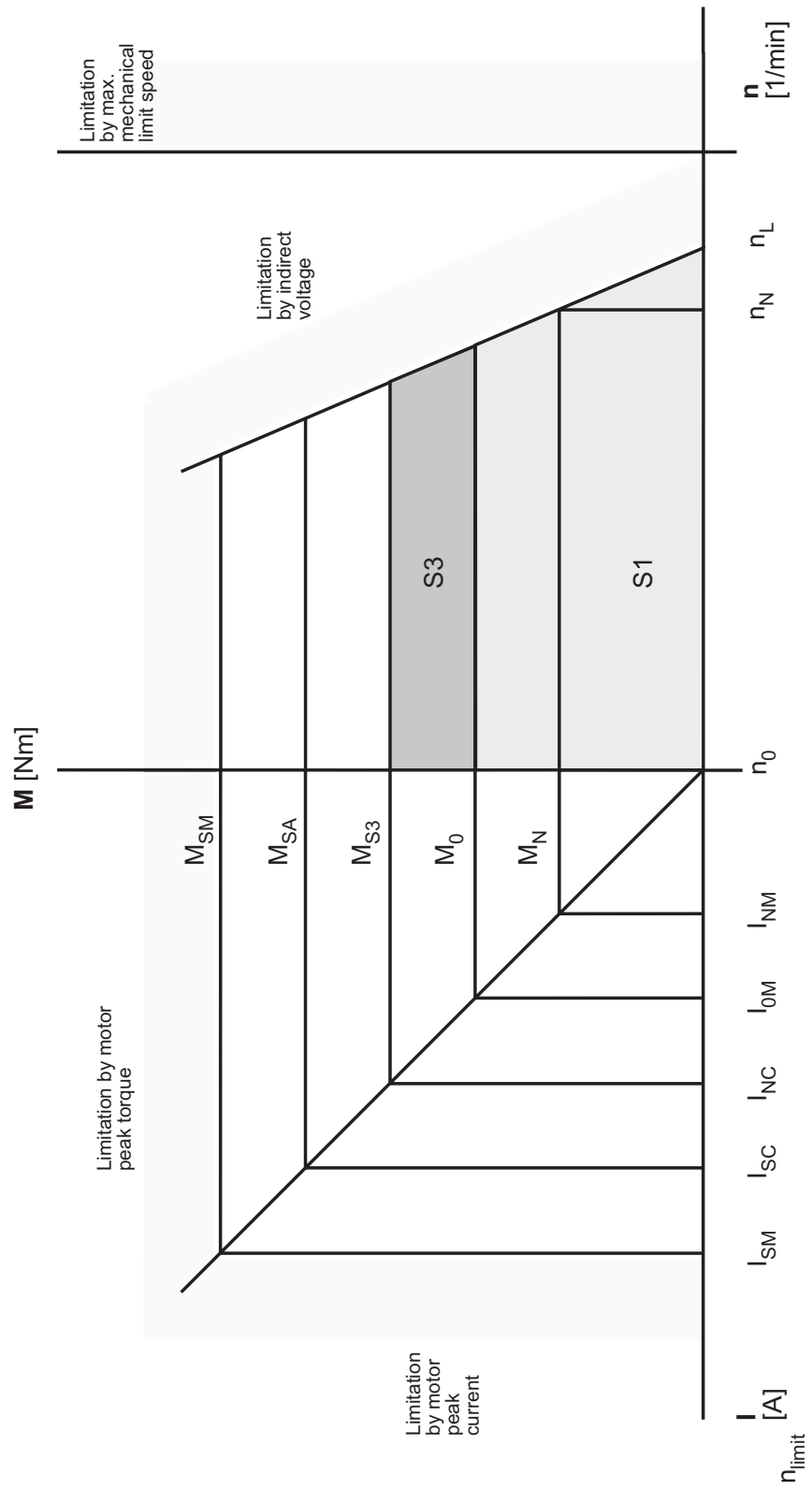

Fig. 6-1: Physical correlations

6.1.2 Ambient conditions, approbations

Parameter	Value
admissible ambient temperature from 0 to 1000 m over NN	0 - 40 °C with higher temperatures, power reduction by 1% per °C
air humidity	class F according to DIN 40040
insulation class	F
approbations	UL / cUL / CE

Table 6-4: Ambient conditions, approbations

Reduced performance in case of higher ambient temperature and / or lower air pressure

If you operate the motors outside the specified nominal data, the motors may be damaged. The effects of ambient temperature and installation height are described below.

Increased ambient temperature The maximum ambient temperature allowed for the SM motor is 40°C. If the ambient temperature rises to a maximum of 55°C, the rated current drops by 1% for each °C.

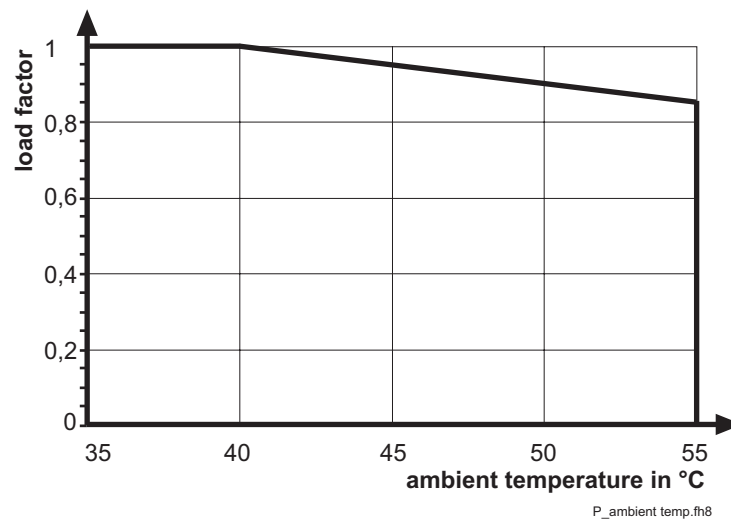

Fig. 6-2: Reduced performance in case of higher ambient temperature

In the border range from 40°C to 55°C, multiply the performance data with the load factor you determined for the ambient temperature.

Low air pressure In environments less than 1000 meters above the sea level, no noteworthy performance reduction due to air pressure is to be expected for SM motors. For heights greater than 1000 meters above the sea level, note the performance data set forth in the diagram below.

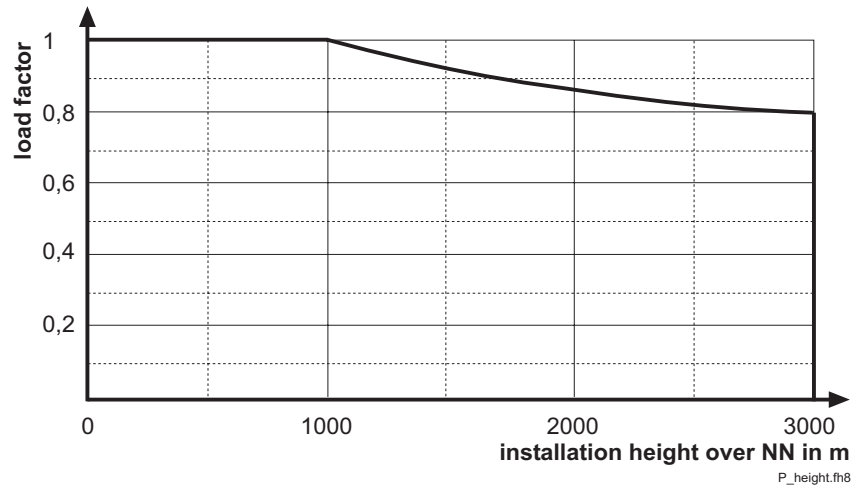

Fig. 6-3: Reduced performance when exceeding the installation height

In the border range from 1000 m to 3000 m, multiply the performance data with the load factor you determined for the installation height.

In case of a performance reduction resulting from both causes, multiply the two load factors with the performance values.

6.1.3 Protection class

The protection class of the SM motor depends on the position in which it is mounted.

All motor types have a fixing flange that makes it possible to install them according to method B5 (fixing flange with through holes).

According to DIN 42950 part 1 (edition 08.77), the motors can be mounted on the machine as follows:



Structural shape	Admissible mounting positions according to DIN IEC 34-7		
B05	 IM B5	 IM V1	 IM V3

Fig. 6-4: Mounting positions of the motor



CAUTION!

Inadmissible mounting position!

Penetrating liquid causes motor damage!

- When installing the motor in position IM V3, make sure that there are no liquids at the drive shaft for a longer time. Even if a shaft seal is built in, one cannot rule out with absolute certainty that liquid penetrates into the motor casing along the drive shaft.

Motor part	Protection class	Mounting position
shaft	IP 64 IP 60	IM B5, IM V1 IM V3
shaft sealing	IP 65	IM B5, IM V1, IM V3
shaft with barrier pressure system	IP 67	IM B5, IM V1, IM V3
surface / connection box	IP 65	IM B5, IM V1, IM V3
surface / connection box with barrier pressure system	IP 67	IM B5, IM V1, IM V3
fan (optional)	IP 20	IM B5, IM V1, IM V3

Table 6-5: Protection means of SM Motors

6.1.4 Motor shaft and bearing

Execution of the shaft end

Smooth shaft end (standard)

With a frictional connection, torque transmission must be achieved by pressure only. This ensures a safe load transmission without play.

Manufacturer	Designation	Remarks
KTR Kupplungstechnik GmbH Rodder Damm 170 48432 Rheine	CLAMPEX clamp set	SM 070: KTR 250 - 11x18
Spieth Maschinenelemente Alleenstraße 41 73730 Esslingen	Spieth pressure sleeve series DSM	SM 100: DSM 19.2 SM 140: DSM 24.2

Table 6-6: Manufacturers of frictional connections

Shaft end with round-ended feather key according to DIN 6885

Shaft connections with round-ended feather key are form-fit. Under continuous duty with variable torque rates or high reversing activity, the position of the round-ended feather key may deflect. This reduces the quality of smooth running (a play develops!). Increasing deformation may cause the round-ended feather key to break and thus damage the shaft. For this reason, this kind of shaft-hub connection is suitable only for low strain. We recommend using smooth shaft ends.

Bearing

The bearing on the A side is a fixed bearing, on the B side is a loose bearing. Thus heat expansion of the slide has no effect on the A side.

Admissible shaft strain

Fig. 6-5: Definition of shaft strain

Motor	1000 1/min	2000 1/min	3000 1/min	4000 1/min	5000 1/min	6000 1/min
SM 070xx010	546	447	398	360	324	306
SM 070xx020	607	497	428	388	360	340
SM 100xx030	927	755	652	590	548	
SM 100xx050	1000	820	710	643		
SM 100xx080	1100	896	775	701		
SM 140xx120	1335	1095	940	851		
SM 140xx210	1445	1185	1020	923		
SM 140xx290	1515	1240	1070	968		
SM 140xx370	1560	1280	1100	996		

 Table 6-7: Admissible radial force F_{radial} [N]

Basis for calculation:

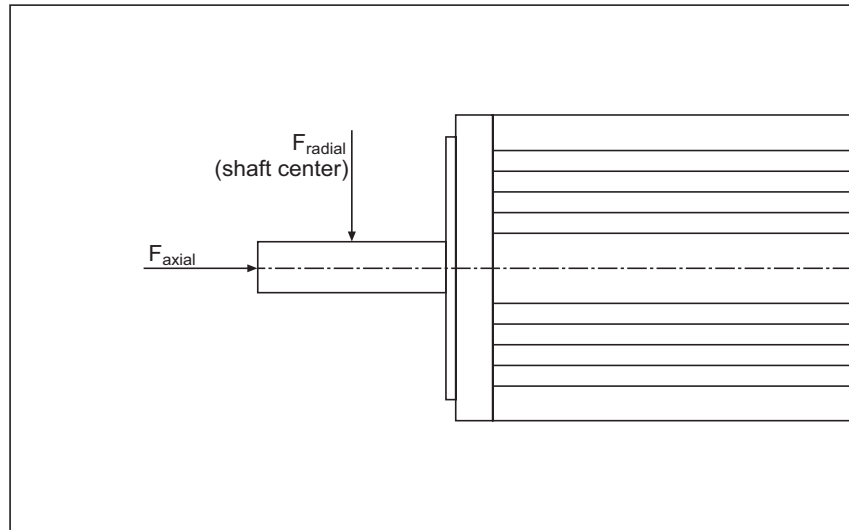
20.000 hours of operation as rated bearing life L_{10h} for a shaft without feather groove.

admissible axial force F_{axial} [N]

$$F_{\text{axial}} = 0,2 \times F_{\text{radial}}$$

6.1.5 Encoders

SinCos

Parameter	Value	Unit
number of sinus-cosine phases per revolution	1024	
dimensions	see dimensional drawing	mm
rotor moment of inertia	10	gcm ²
code type for absolute value	binary	
code development for clockwise shaft rotation, looking on >A< (see dimensional drawing)	rising	
measuring step after arc tangent formation with 12 bit resolution	0.3	angular seconds
number of steps per revolution „SRS single-turn“	32.768	
number of steps per revolution „SRM multi-turn“	134.217.728 = 32768 x 4096	
error limits of the digital absolute value via RS 485	+/- 90	angular minutes
error limits for evaluation of the 1024-type signals, integral non-linearity	+/- 45	angular minutes
non-linearity within a sinus, cosine period, differential non-linearity	+/- 7	angular seconds
output frequency for sinus, cosine signals	0 ... 200	kHz
working speed up to which the absolute position can be formed reliably	6000	min ⁻¹
max. angular acceleration	0.2 x 10 ⁶	rad/s ²
operating torque	0.2	Ncm
starting torque	0.4	Ncm
admissible shaft movements - radial movement, static - radial movement, dynamic - axial movement, static - axial movement, dynamic - angular movement at right angle to turning axis, static - angular movement at right angle to turning axis, dynamic	+/- 0.5 +/- 0.1 +/- 0.75 +/- 0.2 +/- 0.005 +/- 0.0025	mm mm mm mm mm/mm mm/mm
bearing life	3.6 x 10 ⁹	revolutions
working temperature range	-20 ... +115	°Celsius
operating temperature range	-20 ... +125	°Celsius

Parameter	Value	Unit
storage temperature range	-40 ... +125	°Celsius
admissible relative air humidity (dewing prohibited)	90	%
shock resistance when mounted according to DIN IEC 68 part 2-27	100/10	g/ms
vibration resistance when mounted according to DIN IEC 68 part 2-6	20/10 ... 2000	g/Hz
protection means according to DIN VDE 0470 part 1 when mounted	IP 40	
EMT according to EN 50082-2 and EN 50081-2		
operating voltage range	7 ... 12	V
recommended supply voltage	8	V
max. operating current without load	80	mA
available memory range in EEPROM	128	Byte
interface signals SIN, REFSIN, COS, REFCOS = process data channel RS 485 = parameter channel	analog, differential, digital	

Table 6-8: Technical data of the SinCos encoder (SRS / SRM)

Resolver

The SM motor can be supplied also with a brushless hollow shaft resolver.

Advantages of brushless hollow shaft resolvers

Brushless resolvers permit accurate positioning, velocity measurement and commutation of brushless electric motors without mechanical or temperature-related restrictions known from other sensors.

Brushless resolvers are excellently suited for industrial applications in rough ambient conditions, as they are largely independent of vibration, shock and increased temperature strain.

Main features

- compact design
- installation directly on the motor or drive shaft, no clutch
- no brushes or contacts
- no ball bearings
- compatibly with resolver/digital transducer

6.1.6 Holding brake (optional)

To hold the axis without play in standstill or while the plant is powerless, the servo motors can be supplied with a holding brake. The permanent magnet brake is a unifacial device that uses the power of a permanently magnetic field to generate brake power (electromagnetic normally closed system).

To lift the brake, the permanently magnetic field is superseded by an electromagnetic field. Safe lifting without residual moment, irrespective of the mounting position, is ensured by a steel spring. In addition to friction-free axial armature movement, the spring also provides for play-free transmission of the brake moment.



DANGER!

Descending axes!

Persons run the risk of squeezing or cutting off limbs.

- The holding brake alone does not guarantee personal protection. To protect people, provide for superior constructive measures, e.g. protective grid, or furnish the plant with a second brake.
-



CAUTION!

Holding brake may wear out prematurely!

Risk of personal injury!

- Only use holding brake during standstill
 - Only use holding brake to stop a moving axis in EMERGENCY STOP situations.
-

The motors must not be operated against the closed brake. An emergency stop of the motor (i.e. the brake drops while the motor is running) is only allowed in exceptional cases, if the following conditions are met:

- The required brake power per emergency stop must not exceed the following values:
 - SM-070: 50 Ws
 - SM-100: 200 Ws
 - SM-140: 400 Ws

- Between two emergency stops, the brakes must cool down for at least 3 minutes.
- After 2000 emergency stops, the brake has reached its wearing limit.



NOTE

There are only a few diagnosis messages of the MotorController (MC-4 diagnosis messages with reaction A) which do not permit a controlled stop of the motor. In these few cases, the holding brake of the motor is required for the complete brake procedure (EMERGENCY STOP).

Example: To check whether the brake power is not exceeded in case of EMERGENCY STOP, observe the following:

Motor type: SM-070 60 020 with $J_M = 0.79 \text{ kgcm}^2$

Load: $J_{\text{Load}} = 1.5 \text{ kgcm}^2$

Speed: 2000 min^{-1}

$$W_K = \frac{1}{2} \cdot J \cdot \omega^2$$

$$W_K = \frac{1}{2} \cdot J \cdot (2 \cdot \pi \cdot n)^2$$

$$W_K = \frac{1}{2} \cdot 0,000229 \text{ kg} \cdot \text{m}^2 \cdot \left(2 \cdot \pi \cdot \frac{2000}{60} \cdot \frac{1}{\text{s}}\right)^2$$

$$W_K = \frac{1}{2} \cdot 0,000229 \cdot \frac{\text{N} \cdot \text{s}^2}{\text{m}} \text{m}^2 \cdot \left(2 \cdot \pi \cdot \frac{2000}{60} \cdot \frac{1}{\text{s}}\right)^2$$

$$W_K = 5 \text{Ws}$$

The times are valid for direct current, regular operating temperature and rated voltage. *Separation time* is the time from switching on the power to the point when the torque has faded to 10% of the rated torque. *Connection time* is the time from switching off the power until the rated torque is reached.

CAUTION!

Power loss in case of long cables!

Brake may be worn out or damaged!

- The data for rated power and rated voltage apply at the connection box. Check the data at the connection box. A higher or separate power supply of the brake may be necessary.
- Too high voltage can damage the brake!

The holding brake is dimensioned differently for each motor series:

	SM 070	SM 100	SM 140	Unit
holding moment	2.5 (22.2)	11 (97.4)	22 (195)	[Nm] ([lb-in.])
connection time	5	20	25	[ms]
separation time	7	29	50	[ms]
mass	0.3	0.6	1.1	[kg]
moment of inertia	0.38 (0.00034)	1.06 (0.00094)	3.6 (0.0032)	[kgcm ²] ([lb-in.-s ²])
rated power	12	16	18	[W]
rated voltage	24 +/- 10%	24 +/- 10%	24 +/- 10%	[V] DC

Table 6-9: Technical data of the holding brake of the SM Motor

Holding brake grind in

If the motors are equipped with a holding brake and were already stored for more than 2 years before the assembly, the holding brake has to be ground in before you use it.

CAUTION!

High voltage!

Life hazard!

- Grind in the holding brake only in the developed status of the motor!

▶ In addition turn the motor by hand for approx. 50 revolutions in the closed state of the holding brake.

✓ The holding brake is now ready for use.

6.1.7 Surface Ventilation (optional)

To increase the permanent motor torque, the SM Motors can be supplied with surface ventilation.

The surface ventilation reduces the thermal transition resistance, so that the permanent torque characteristics of the motor are shifted upwards. The peak motor torque is not changed.

The increased permanent torque values are saved in the electronic type plate of the motor or the motor database.

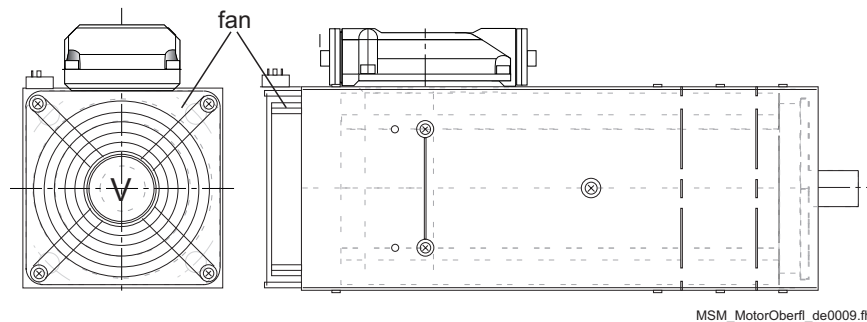

Fig. 6-6: Example for an SM motor with surface ventilation

The fan is dimensioned differently for each motor series:

	SM 070	SM 100	SM 140	Unit
rated voltage	230	230	230	[V] AC
power intake	approx. 0.05	approx. 0.1	approx. 0.15	[A]

Table 6-10: Technical data of the fans

6.1.8 Technical Data in Detail

Technical Data SM 070

Winding data for 6000 rpm with 3 AC 400 V

Reference Data	mnemonic	60 010	60 020	Unit
Standstill torque (standard) - motor with surface ventilation	M_{0M}	1.1 -	2.0 2.7	[Nm]
Rated speed	n_N	6000	6000	[rpm]
Fringe motor power	P_{ECKM}	0.7	1.2	[kW]
Peak torque	M_{SM}	4.7	7.7	[Nm]
Physical data				
Max. mechanical limit rpm	n_{limit}	700	700	[rad/s]
Motor moment of inertia	J_M	0.48	0.79	[kgm ²]
Acceleration at M_{SM}	A_{SM}	129 175	125 230	[rad/s ²]
Max. shock (all directions)	S	200	200	[m/s ²]
Max. vibration (radial)	V_R	200	200	[m/s ²]
Max. vibration (axial)	V_A	40	40	[m/s ²]
Mass	m	2.75	4.25	[kg]
Run-up time	t_{bSM}	5	5	[ms]
Thermal data				
Thermal time constant	t_A	46	43	[min]
Operating threshold thermo contact	T_{TK}	130	130	[°C]
Electrical data				
Number of poles	PZ	4	4	
Circuit of the motor windings		Y	Y	
Torque constant (20°C)	K_{M20}	0.86	0.85	[Nm/A]
Torque constant (120°C)	K_{M120}	0.78	0.78	[Nm/A]
Winding resistance (120°C)	R_{W120}	12.39	4.69	[Ohm]
Winding inductivity (20°C)	L_W	21.9	10.8	[mH]
EMC at 1000 rpm	EMC	52	52	[V]
Standstill current - motor with surface ventilation	I_{0M}	1.43 -	2.53 3.46	[A]
Peak current	I_{SM}	6.0	9.9	[A]

Table 6-11: Technical data SM 070

Technical Data SM 100

Winding data with 3 AC 400 V

Reference Data	mnemonic	50 030	40 050	40 080	30 080	Unit
Standstill torque (standard) - motor with surface ventilation	M _{0M}	2.6 -	4.8 -	8.0 13	8.2 14	[Nm]
Rated speed	n _N	5000	4000	4000	3000	[rpm]
Fringe motor power	P _{ECKM}	1.4	2.0	3.4	2.6	[kW]
Peak torque	M _{SM}	10	16	30	27	[Nm]
Physical data						
Max. mechanical limit rpm	n _{limit}	700	700	700	700	[rad/s]
Motor's moment of inertia	J _M	2.28	3.64	6.54	6.54	[kgcm ²]
Acceleration at M _{SM}	A _{SM}	55 885	54 308	47 188	49 168	[rad/s ²]
Max. shock (all directions)	S	200	200	200	200	[m/s ²]
Max. vibration (radial)	V _R	200	200	200	200	[m/s ²]
Max. vibration (axial)	V _A	50	40	40	40	[m/s ²]
Mass	m	4.9	7	11.2	11.2	[kg]
Run-up time	t _{bSM}	9	8	9	6	[ms]
Thermal data						
Thermal time constant	t _A	44	54	51	56	[min]
Operating threshold thermo contact	T _{TK}	130	130	130	130	[°C]
Electrical data						
Number of poles	PZ	8	8	8	8	
Circuit of the motor windings		Y	Y	Y	Y	
Torque constant (20°C)	K _{M20}	1.00	1.27	1.32	1.65	[Nm/A]
Torque constant (120°C)	K _{M120}	0.91	1.15	1.2	1.5	[Nm/A]
Winding resistance (120°C)	R _{W120}	5.61	2.94	1.39	2.07	[Ohm]
Winding inductivity (20°C)	L _W	9.08	7.29	3.97	6.20	[mH]
EMK at 1000 rpm	EMK	60	77	80	100	[V]
Standstill current - motor with surface ventilation	I _{0M}	2.87 -	4.19 -	6.68 10.9	5.48 9.33	[A]
Peak current	I _{SM}	11	14	25 (22)	18	[A]

Table 6-12: Technical Data SM 100

Technical Data SM 140

Winding data for 3000 rpm with 3 AC 400 V

Reference Data	mnemonic	30 120	30 210	30 290	30 370	Unit
Standstill torque (standard) - motor with surface ventilation	M_{0M}	11 17	20 35	29 46	36 57*	[Nm]
Rated speed	n_N	3000	3000	3000	3000	[rpm]
Fringe motor power	P_{ECKM}	3.4	6.5	8.6	11	[kW]
Peak torque	M_{SM}	45	76	103	126	[Nm]
Physical data						
Max. mechanical limit rpm	n_{limit}	700	700	700	700	[rad/s]
Motor's moment of inertia	J_M	10.3	18.1	24.9	33.1	[kgcm ²]
Acceleration at M_{SM}	A_{SM}	46889	52473	53027	51485	[rad/s ²]
Max. shock (all directions)	S	200	200	200	200	[m/s ²]
Max. vibration (radial)	V_R	200	200	200	200	[m/s ²]
Max. vibration (axial)	V_A	40	40	40	40	[m/s ²]
Mass	m	10	14	18	22	[kg]
Run-up time	t_{bSM}	7	6	6	6	[ms]
Electrical data						
Thermal time constant	t_A	70	88	91	98	[min]
Operating threshold thermo contact	T_{TK}	130	130	130	130	[°C]
Electrical data						
Number of poles	PZ	8	8	8	8	
Circuit of the motor windings		Y	Y	Y	Y	
Torque constant (20°C)	K_{M20}	1.70	1.78	1.80	1.78	[Nm/A]
Torque constant (120°C)	K_{M120}	1.55	1.62	1.64	1.62	[Nm/A]
Winding resistance (120°C)	R_{W120}	1.65	0.57	0.36	0.24	[Ohm]
Winding inductivity (20°C)	L_W	9.64	3.4	1.89	1.23	[mH]
EMC at 1000 rpm	EMC	103	108	109	108	[V]
Standstill current - motor with surface ventilation	I_{0M}	7.04 11	12.7 22	16.8 28.1	21.8 35.6*	[A]
Peak current	I_{SM}	29	47	63	78	[A]
*In this case, the maximum motor current must be limited to 29.5 A, which is the maximum permissible permanent current tolerance of the power cable.						

Table 6-13: Technical data SM 140 30

Technical Data SM 140

Winding data for 2000 rpm with 3 AC 400 V

Reference Data	mnemonic	20 210	Unit
Standstill torque (standard) - motor with surface ventilation	M_{0M}	21	[Nm]
Rated speed	n_N	2000	[rpm]
Fringe motor power	P_{ECKM}	4.4	[kW]
Peak torque	M_{SM}	78	[Nm]
Physical data			
Max. mechanical limit rpm	n_{limit}	700	[rad/s]
Motor's moment of inertia	J_M	18.1	[kgcm ²]
Acceleration at M_{SM}	A_{SM}	53 303	[rad/s ²]
Max. shock (all directions)	S	200	[m/s ²]
Max. vibration (radial)	V_R	200	[m/s ²]
Max. vibration (axial)	V_A	40	[m/s ²]
Mass	m	14	kg
Run-up time	t_{bSM}	4	[ms]
Thermal data			
Thermal time constant	t_A	91	[min]
Operating threshold thermo contact	T_{TK}	130	[°C]
Electrical data			
Number of poles	PZ	8	
Circuit of the motor windings		Y	
Torque constant (20°C)	K_{M20}	2.59	[Nm/A]
Torque constant (120°C)	K_{M120}	2.36	[Nm/A]
Winding resistance (120°C)	R_{W120}	1.14	[Ohm]
Winding inductivity (20°C)	L_W	7.19	[mH]
EMC at 1000 rpm	EMC	157	[V]
Standstill current	I_{0M}	8.97	[A]
Peak current	I_{SM}	33	[A]

Table 6-14: Technical data SM 140 20 (data apply to flanged on motor at aluminium plate)

6.1.9 Torque-speed characteristics

The torque-speed characteristics depict the following developments:

- admissible permanent torque (operating mode S1)
- peak torque at mains voltage = 230 V 3 AC
- peak torque at mains voltage = 380 V 3 AC
- peak torque at mains voltage = 400 V 3 AC
- peak torque at mains voltage = 480 V 3 AC

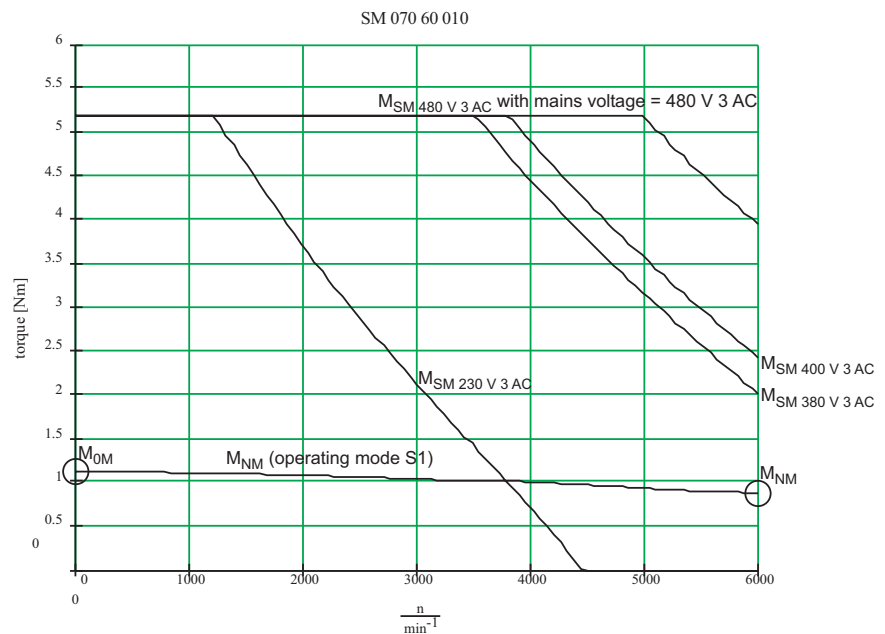

Fig. 6-7: Example of torque-speed characteristics

The characteristics refer to an ambient temperature of 40 °C and a casing overtemperature of 60 °C.



NOTE

With a single-phase mains connection (230 V) the characteristics of „ $M_{SM\ 230\ V\ 3\ AC}$ “ move approx. 20% to the left due to the lower DC-circuit voltage.

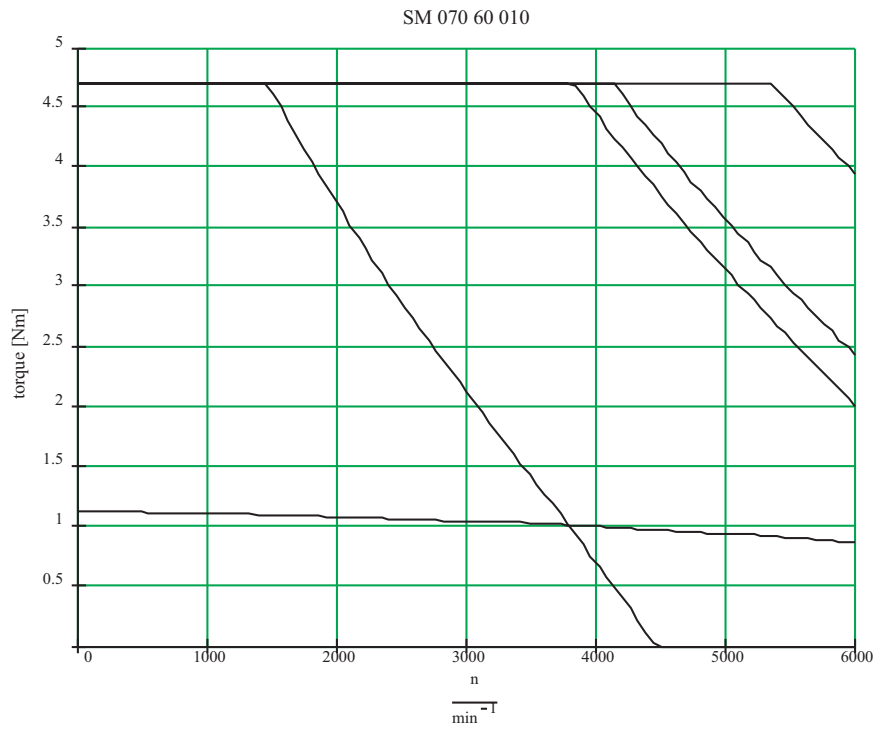

Fig. 6-8: Torque-speed characteristics SM 070 60 010

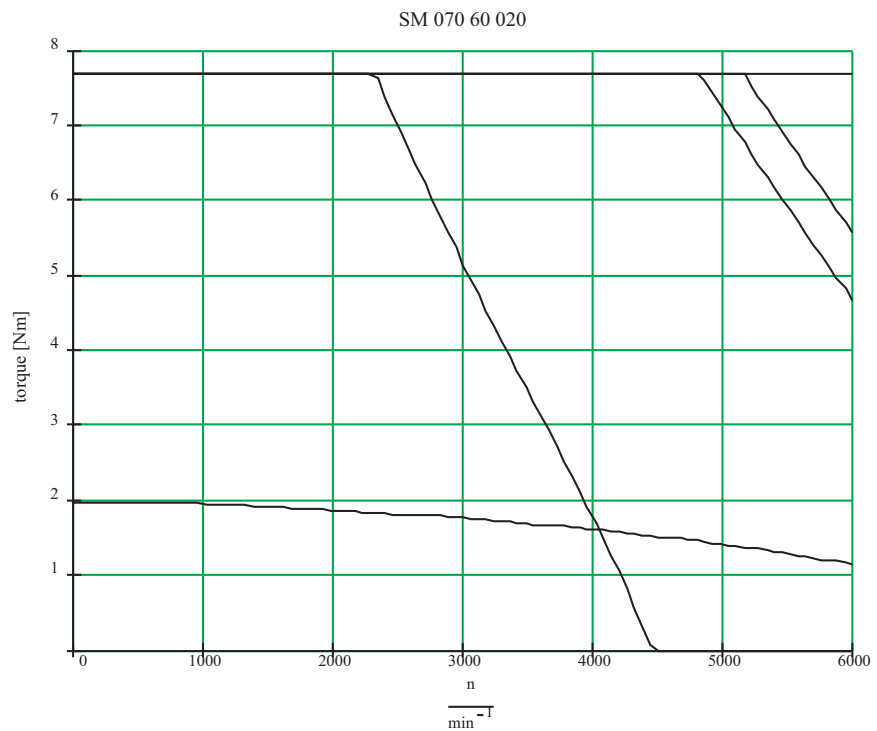

Fig. 6-9: Torque-speed characteristics SM 070 60 020

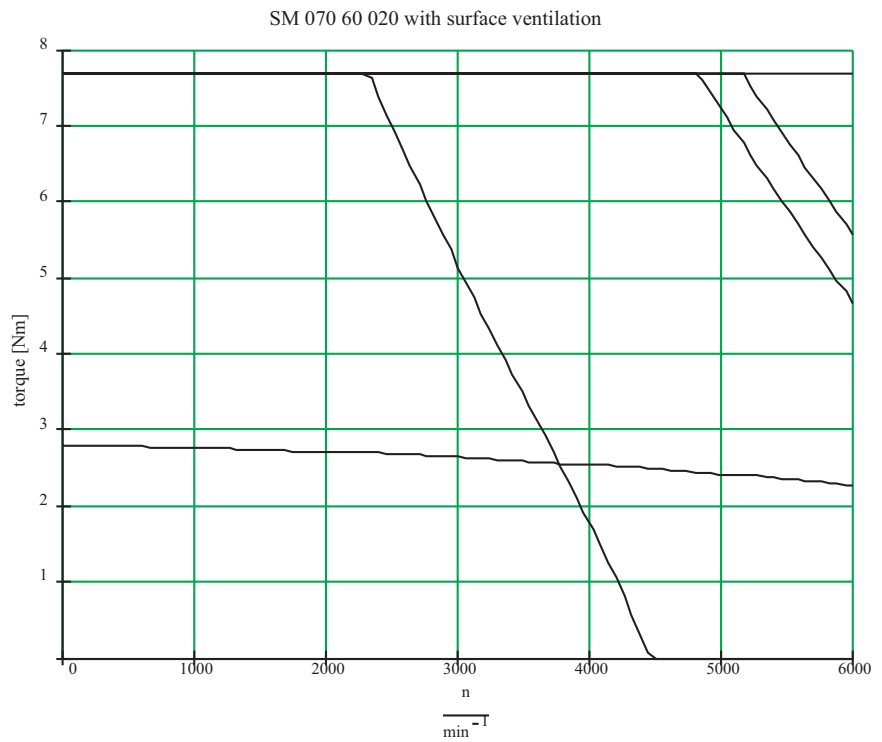

Fig. 6-10: Torque-speed characteristics SM 070 60 020 with surface ventilation

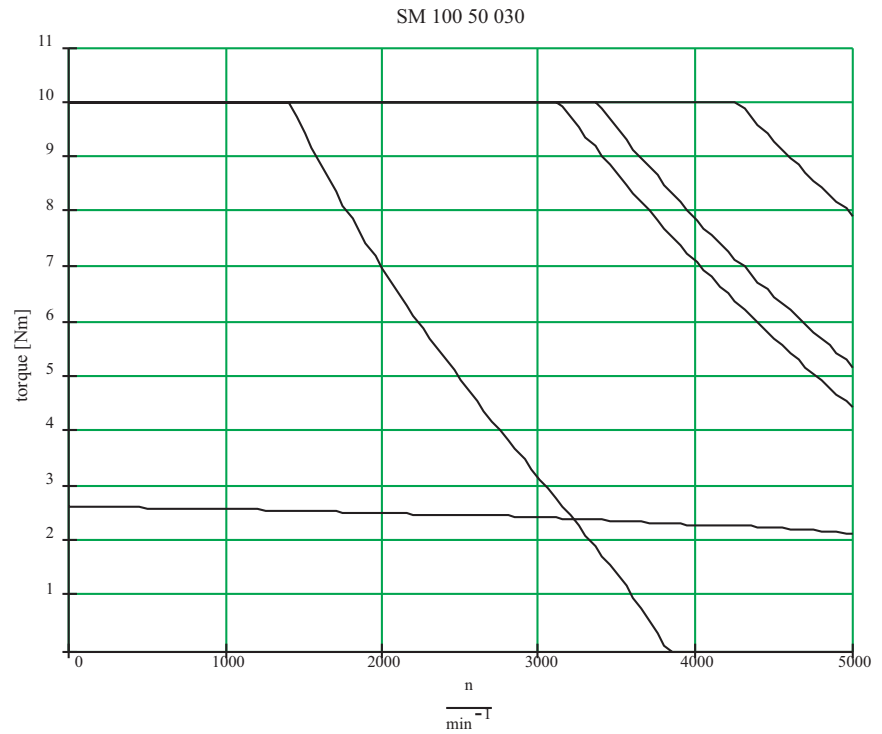

Fig. 6-11: torque-speed characteristics SM 100 50 030

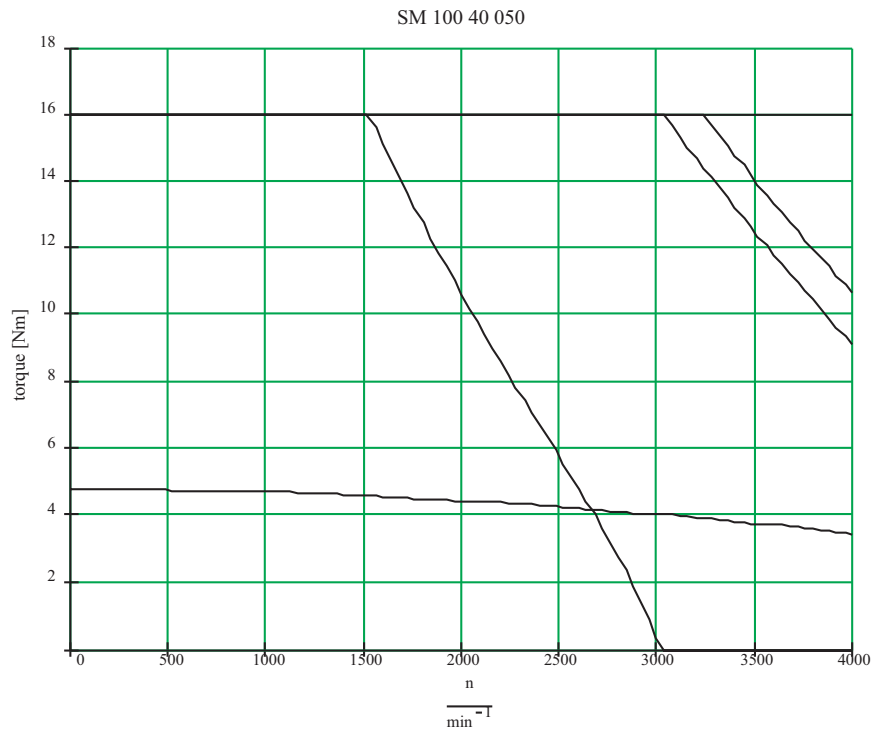

Fig. 6-12: Torque-speed characteristics SM 100 40 050

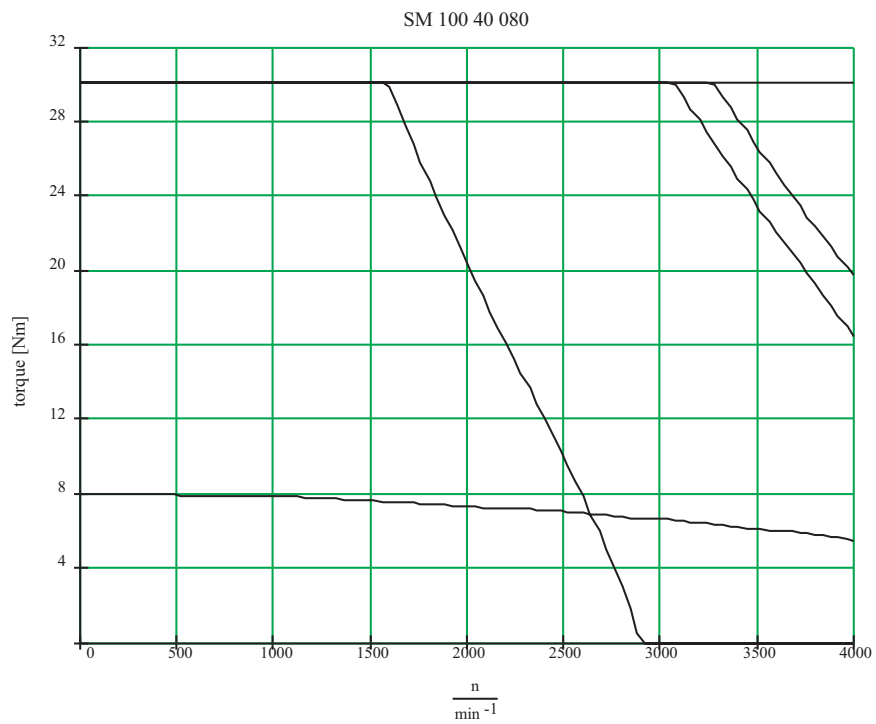

Fig. 6-13: Torque-speed characteristics SM 100 40 080

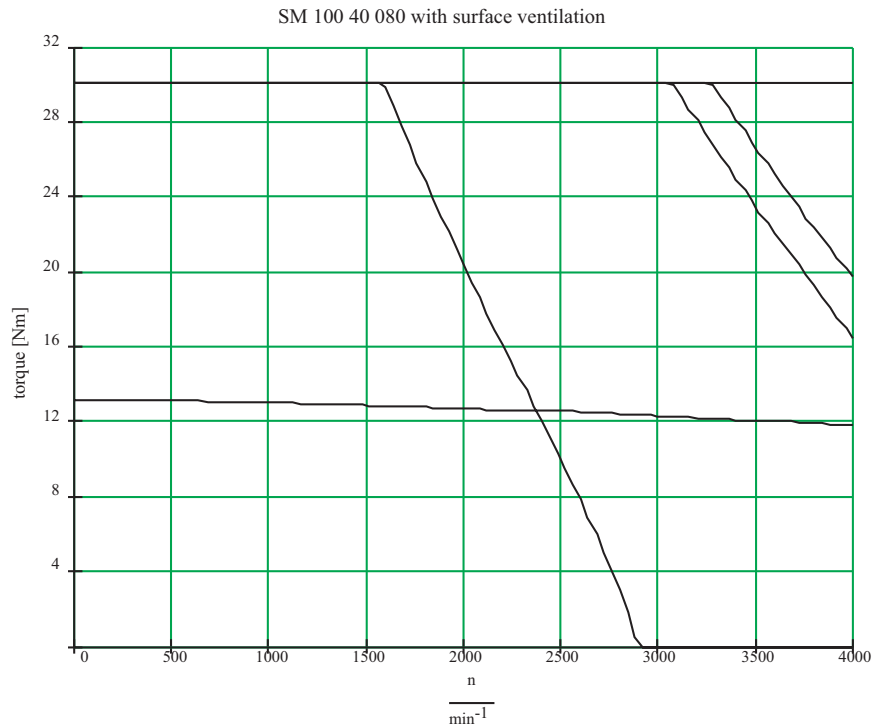

Fig. 6-14: Torque-speed characteristics SM 100 40 080 with surface ventilation

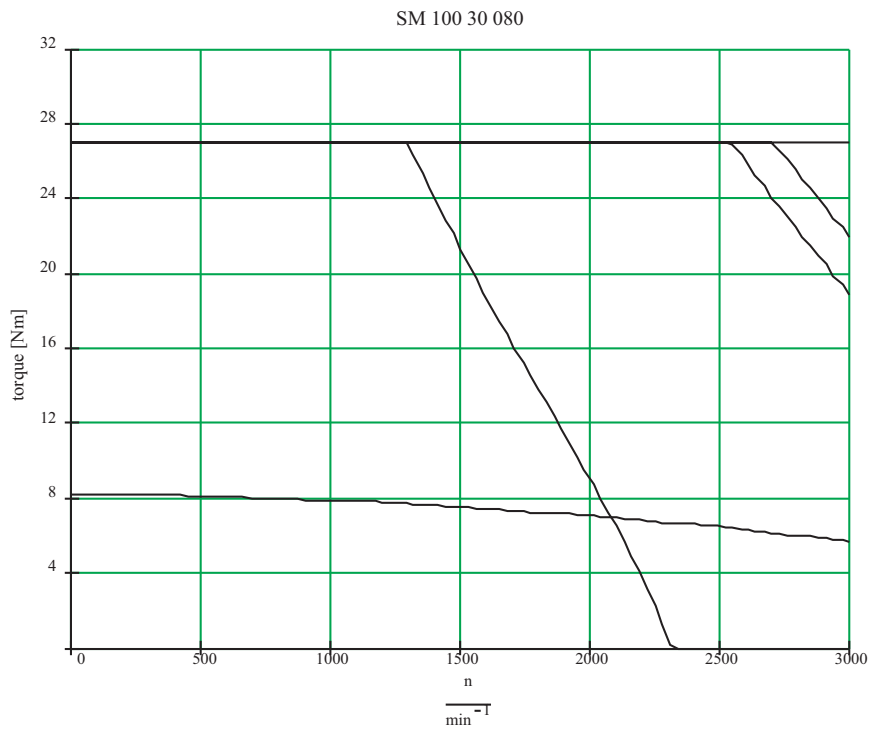

Fig. 6-15: Torque-speed characteristics SM 100 30 080

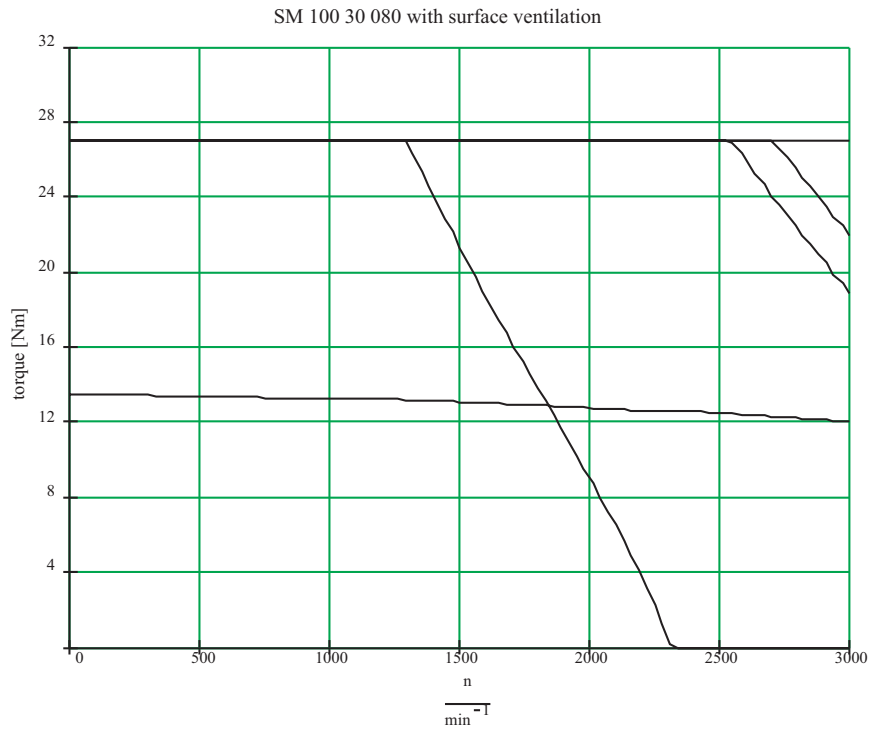

Fig. 6-16: Torque-speed characteristics SM 100 30 080 with surface ventilation

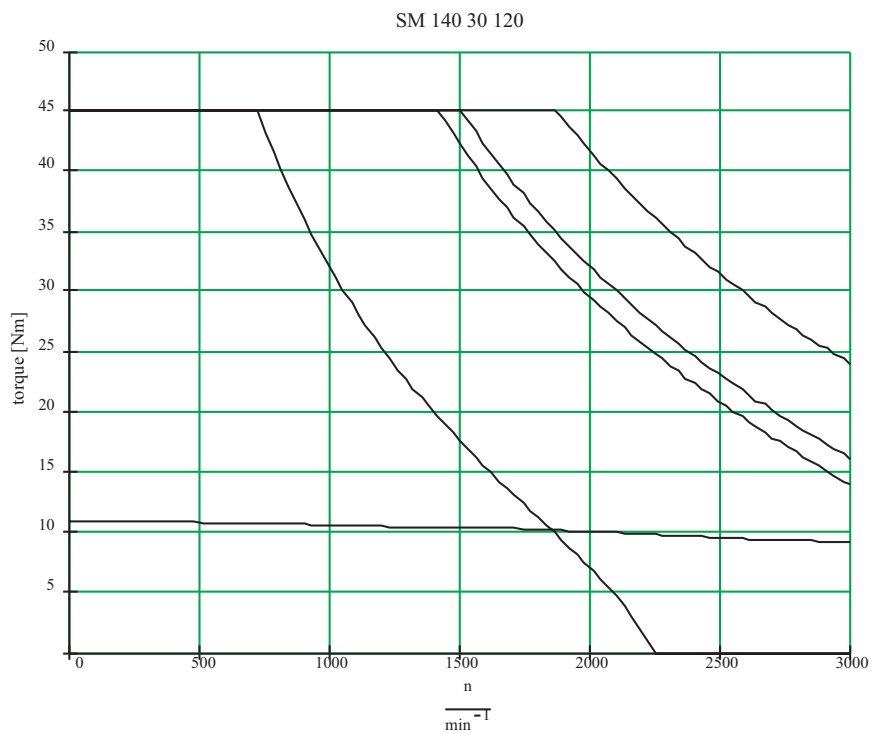

Fig. 6-17: Torque-speed characteristics SM 140 30 120

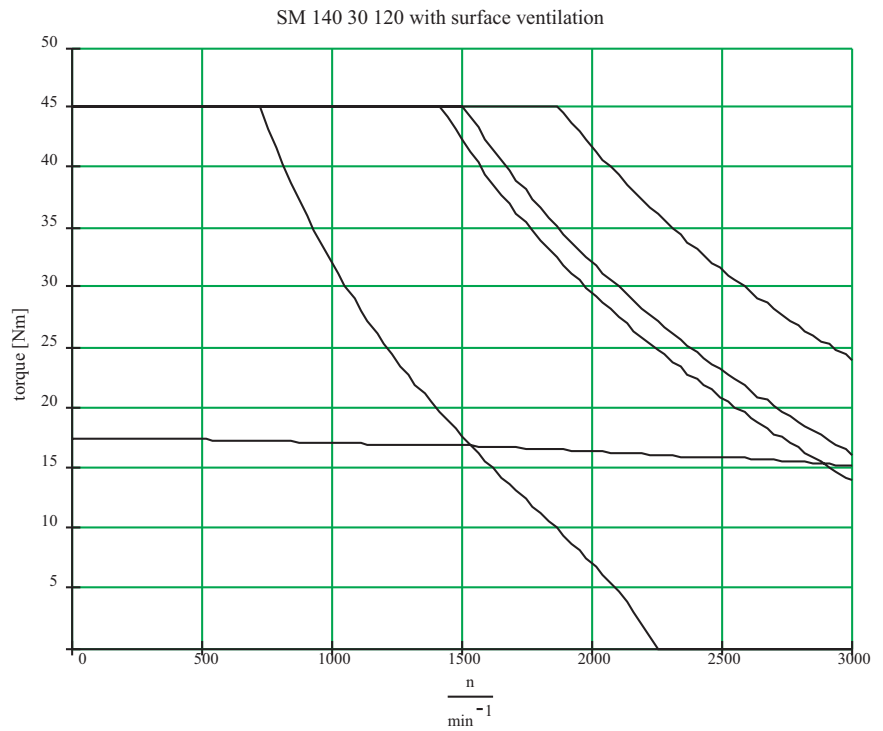

Fig. 6-18: Torque-speed characteristics SM 140 30 120 with surface ventilation

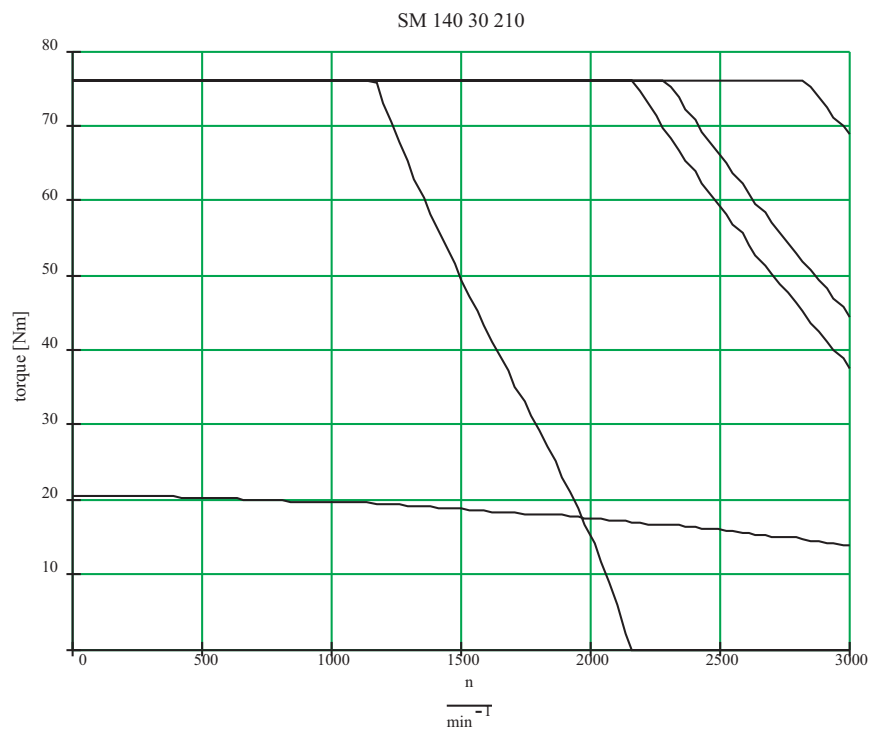

Fig. 6-19: Torque-speed characteristics SM 140 30 210

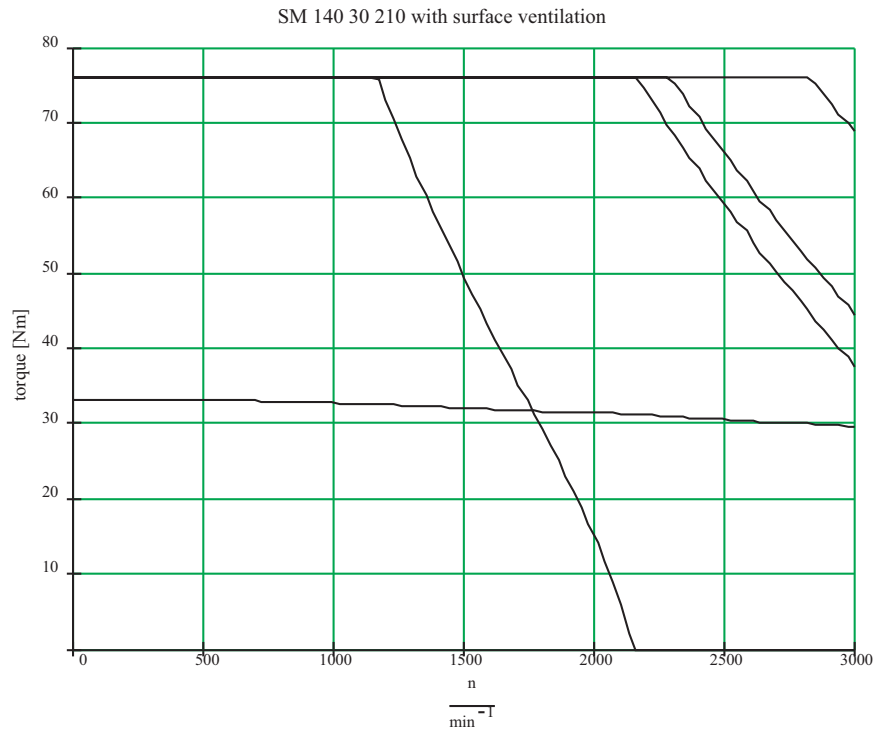

Fig. 6-20: Torque-speed characteristics SM 140 30 210 with surface ventilation

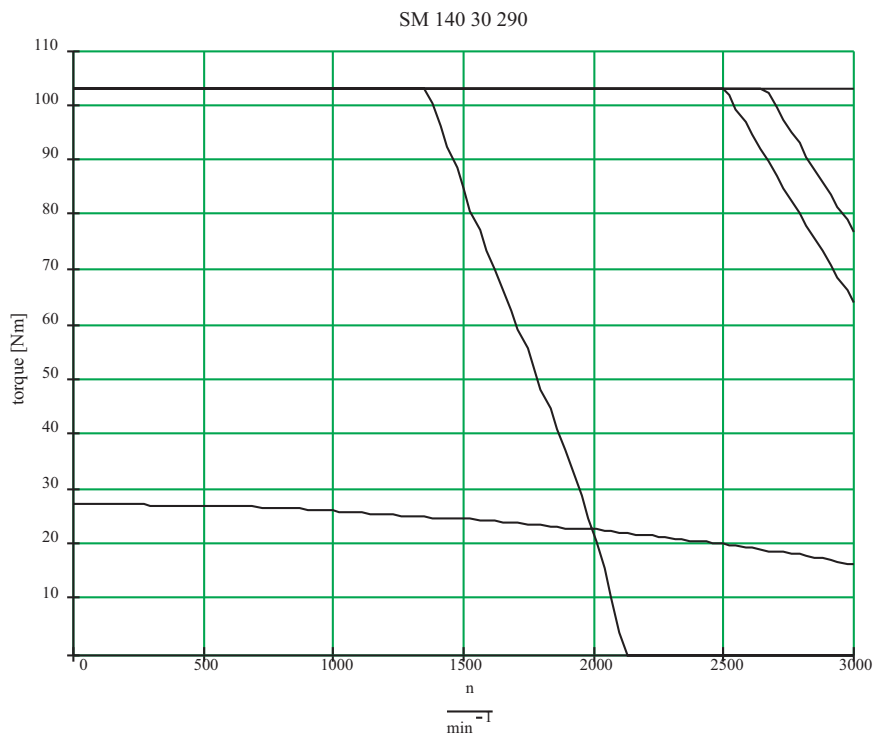

Fig. 6-21: Torque-speed characteristics SM 140 30 290

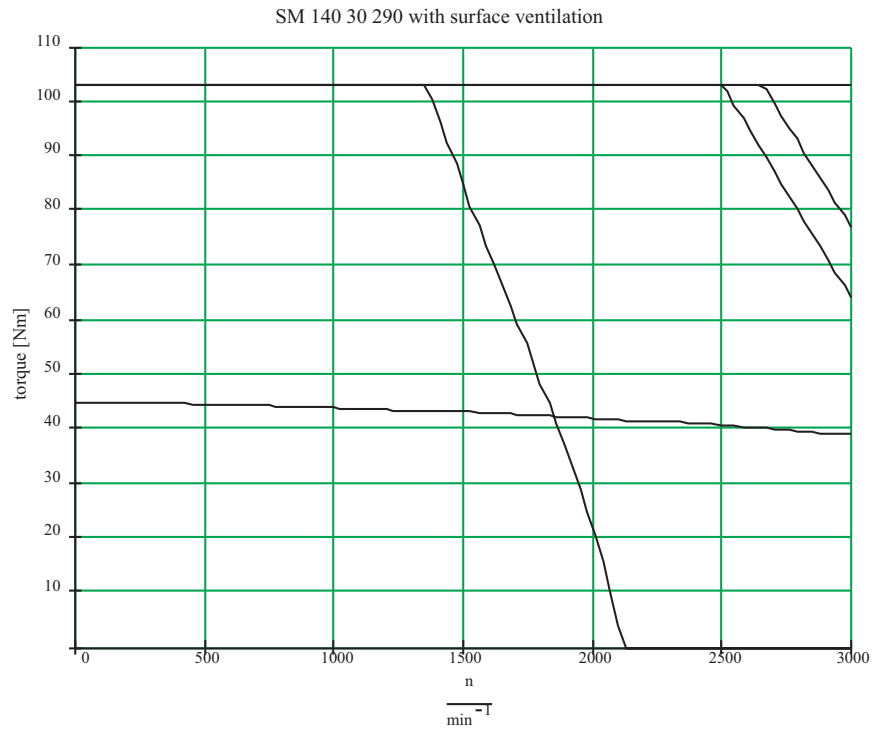

Fig. 6-22: Torque-speed characteristics SM 140 30 290 with surface ventilation

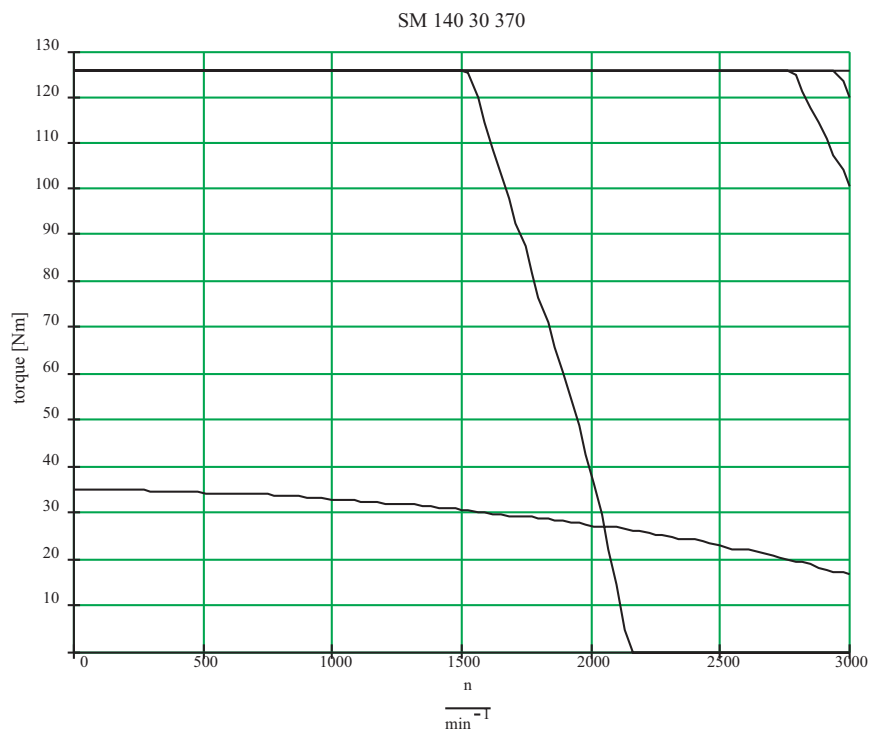

Fig. 6-23: Torque-speed characteristics SM 140 30 370

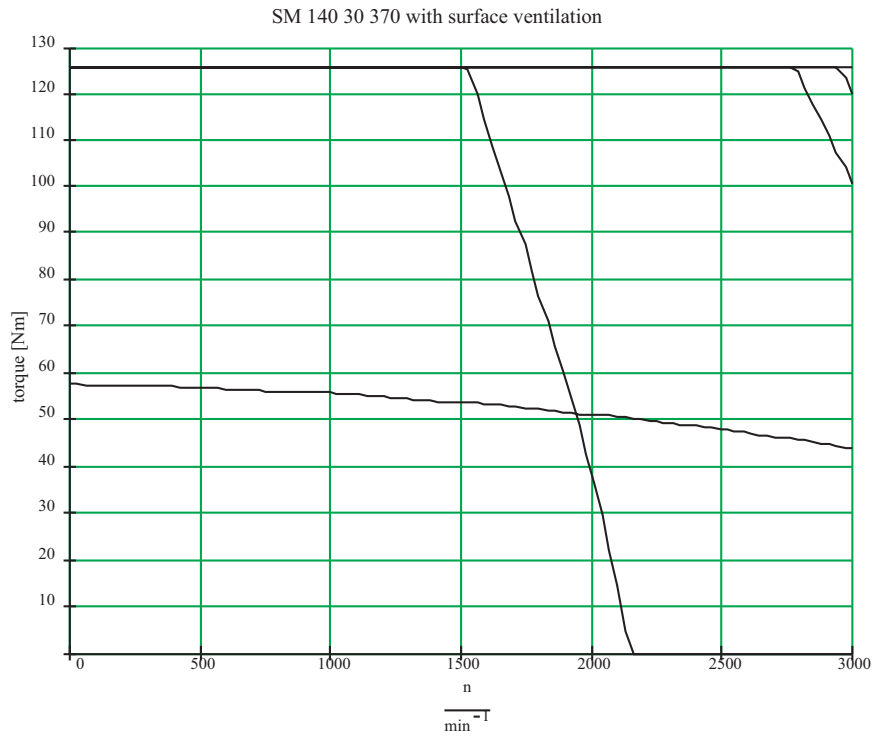

Fig. 6-24: Torque-speed characteristics SM 140 30 370 with surface ventilation

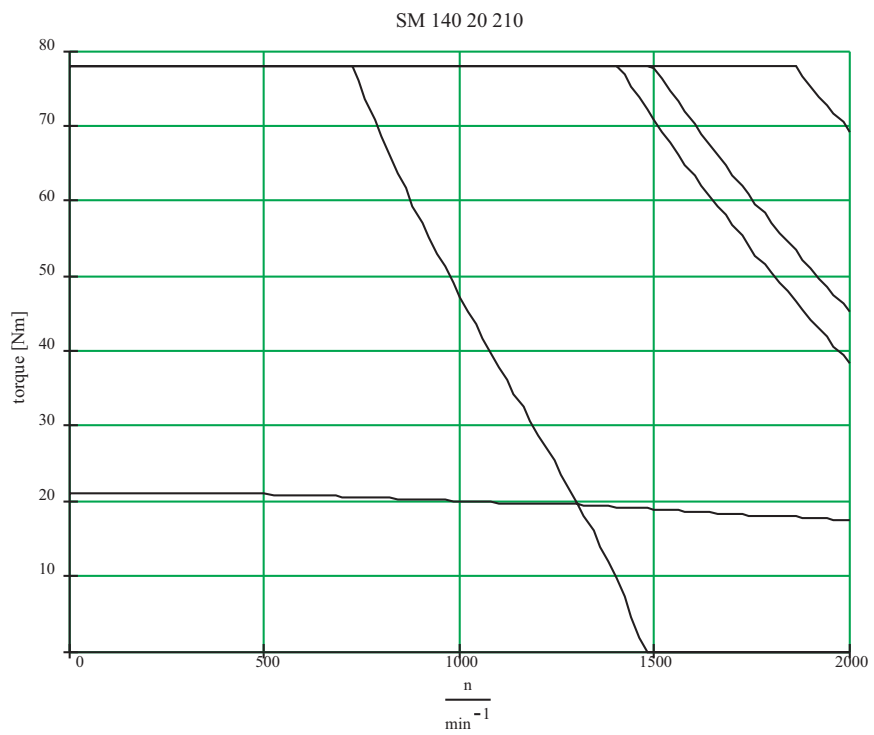

Fig. 6-25: Torque-speed characteristics SM 140 20 210

6.2 Electrical Connections

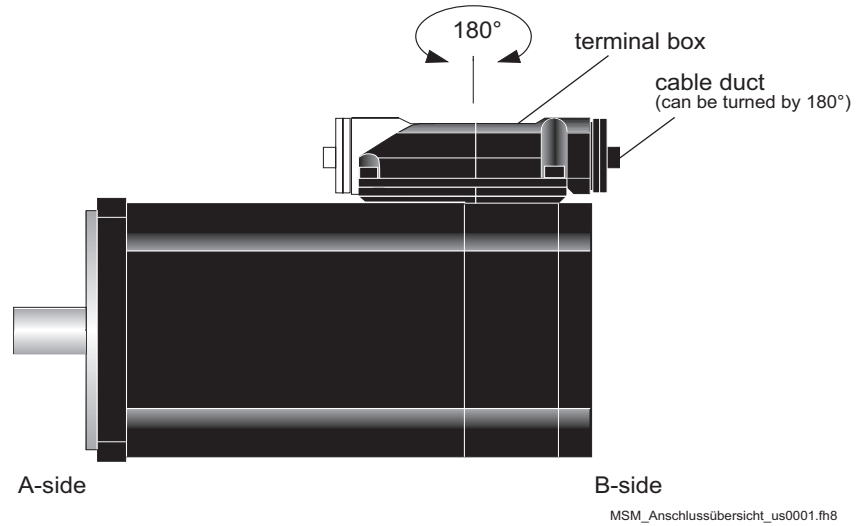

Fig. 6-26: Overview of connections with SM Motor - 1

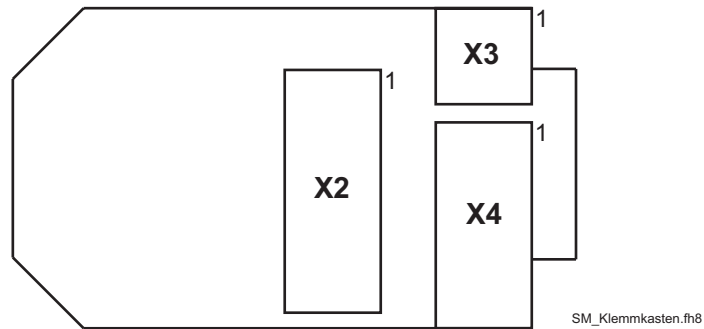

Fig. 6-27: Overview of connections with SM Motor - 2 (terminal box)

Connection of the motor cables to the terminal box, see also chapter 4.3.1 Modified connections.

6.2.1 X2 - motor

Pin	Designation (lead no.)	Meaning	Range	Max. cross section
1	U (1)		3 AC 0 - 480 V	2.5 mm ²
2	V (2)		3 AC 0 - 480 V	2.5 mm ²
3	W (3)		3 AC 0 - 480 V	2.5 mm ²
4	PE	motor earth conductor		2.5 mm ²

Table 6-15: Connection X2 - motor



NOTE

For SM 140 XX 120 and SM 140 XX 210, the X2 connector plug has a different shape and size.

For SM 140 XX 290 and SM 140 XX 370, X2 is a screw clamp, so that also a motor cable with 4 mm² can be connected.

6.2.2 X3 - brake / motor temperature

Pin	Designation (lead no.)	Meaning	Range	Max. cross section
1	temp (5)	PTC motor temperature		1.5 mm ²
2	temp (6)	PTC motor temperature		1.5 mm ²
3	br- (7)	holding brake	DC 0 V	1.5 mm ²
4	br+ (8)	holding brake	DC 24 V	1.5 mm ²

Table 6-16: Connection X3 - SM motor



NOTE

For SM motors SM 140 or higher, the X3 has a different size.



CAUTION!

Poles may be interchanged on the connector plug!

Motor may be damaged!

- Make sure the pin numbers are allocated correctly!

6.2.3 X4 - encoder (SinCos)

Pin	Designation	Meaning	Range	Max. cross section
1	Us	supply voltage	DC 7 - 12 V	0.25 mm ²
2	GND	supply voltage	DC 0 V	0.25 mm ²
3	REFSIN	sinus reference signal		0.25 mm ²
4	SIN	sinus trace		0.25 mm ²
5	REFCOS	cosine reference signal		0.25 mm ²
6	COS	cosine trace		0.25 mm ²
7	RS485-	parameter channel -		0.25 mm ²
8	RS485+	parameter channel +		0.25 mm ²

Table 6-17: Connection X4 - SM motor (SinCos encoder)



CAUTION!

Poles may be interchanged on the connector plug!
Motor may be damaged!

- Make sure the pin numbers are allocated correctly!

6.2.4 X4 - encoder (Resolver)

Pin	Designation	Meaning	Range	Max. cross section
1		reserves		0.25 mm ²
2		reserves		0.25 mm ²
3	SIN -	Sinus -		0.25 mm ²
4	SIN +	Sinus +		0.25 mm ²
5	COS -	Cosinus -		0.25 mm ²
6	COS +	Cosinus +		0.25 mm ²
7	EXCT -	exciter signal -		0.25 mm ²
8	EXCT +	exciter signal +		0.25 mm ²

Table 6-18: Connection X4 - SM motor (Resolver)



CAUTION!

Poles may be interchanged on the connector plug!
 Motor may be damaged!

- Make sure the pin numbers are allocated correctly!

6.3 Dimensions

6.3.1 SM-motor

SM 070

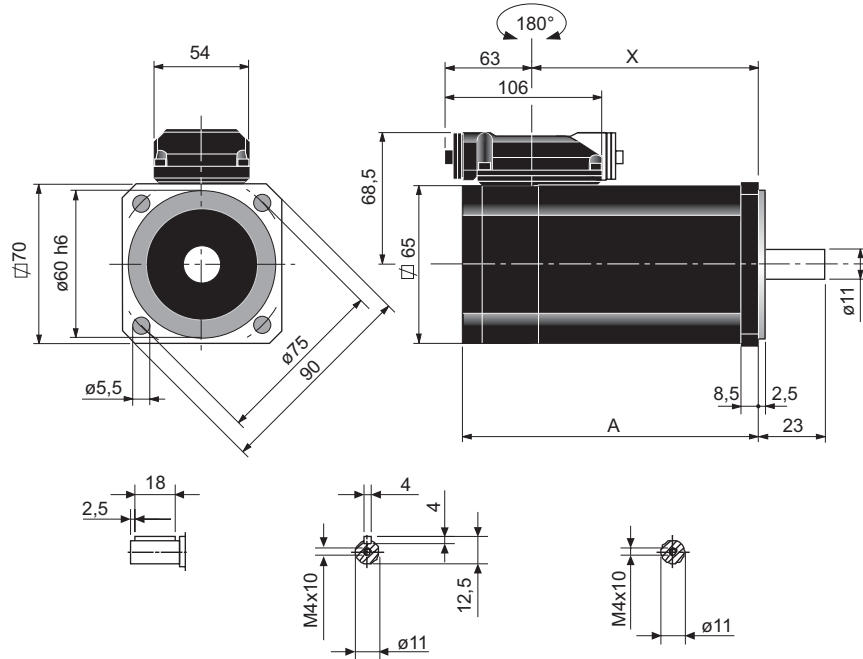

MSM_MasszeichnungSM070_us0006.th8

Fig. 6-28: Dimensional drawing of SM 070

Dimensions	xx 010	xx 020
A	201 (7.91)	261 (10.28)
X	152 (5.98)	212 (8.35)

Table 6-19: Dimensions of SM 070 without brake

Dimensions	xx 010	xx 020
A	230 (9.06)	290 (11.42)
X	181 (7.13)	241 (9.49)

Table 6-20: Dimensions of SM 070 with brake

Tolerances Shaft diameter: j6
 Round-ended feather key, round end according to DIN 6885 T1, tolerance field N9
 Rotor balanced with half feather key.

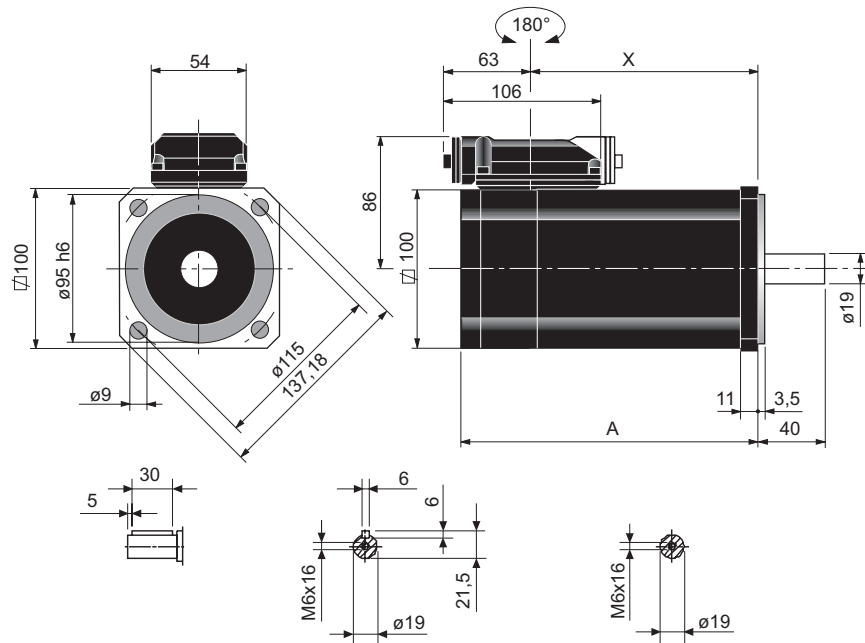
SM 100

MSM_MasszeichnungSM100_us0006.fh8

Fig. 6-29: Dimensional drawing of SM 100

Dimensions	xx 030	xx 050	xx 080
A	196 (7.72)	240 (9.45)	328 (12.91)
X	147 (5.79)	191 (7.52)	279 (10.98)

Table 6-21: Dimensions of SM 100 without brake

Dimensions	xx 030	xx 050	xx 080
A	231 (9.09)	275 (10.83)	363 (14.29)
X	182 (7.17)	226 (8.90)	314 (12.36)

Table 6-22: Dimensions of SM 100 with brake

Tolerances Shaft diameter: j6
 Round-ended feather key, round end according to DIN 6885 T1, tolerance field N9
 Rotor balanced with half feather key.

SM 140

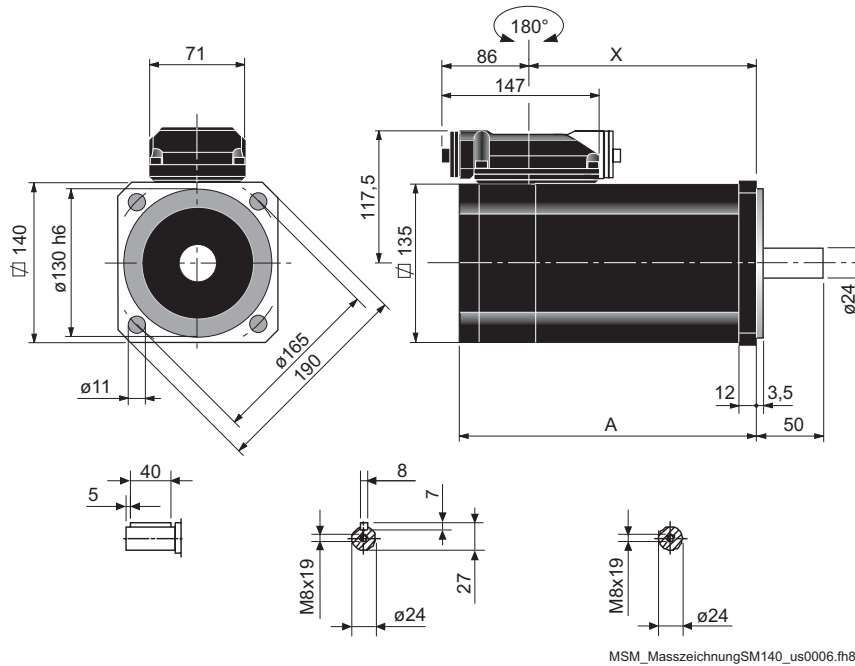

Fig. 6-30: Dimensional drawing of SM 140

Dimensions	xx 120	xx 210	xx 290	xx 370
A	248 (9.76)	310 (12.20)	372 (14.65)	434 (17.09)
X	178 (7.01)	240 (9.45)	302 (11.89)	364 (14.33)

Table 6-23: Dimensions of SM 140 without brake

Dimensions	xx 120	xx 210	xx 290	xx 370
A	288 (11.34)	350 (13.78)	412 (16.22)	474 (18.66)
X	218 (8.58)	280 (11.02)	342 (13.46)	404 (15.91)

Table 6-24: Dimensions of SM 140 with brake

Tolerances

Shaft diameter: j6
 Round-ended feather key, round end according to DIN 6885 T1, tolerance field N9
 Rotor balanced with half feather key.

SM Motor with surface ventilation

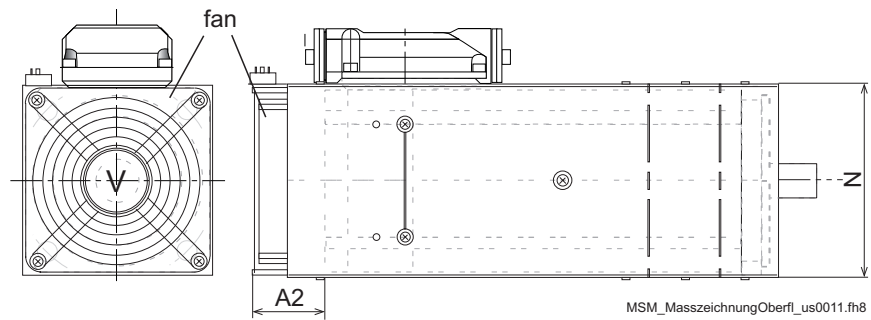

Fig. 6-31: Dimensional drawing of SM-Motor with surface ventilation

If an SM Motor has surface ventilation, the motor gets longer. Add the size A2 to the size A of the „standard motor“.

SM motor	Size A2	Size N
SM 070	approx. 59 mm (2.32)	approx. 110 mm (4.33)
SM 100	approx. 59 mm (2.32)	approx. 145 mm (5.71)
SM 140	approx. 70 mm (2.76)	approx. 170 mm (6.69)

Table 6-25: Dimensions of SM Motor with surface ventilation

6.3.2 SP-Gearbox

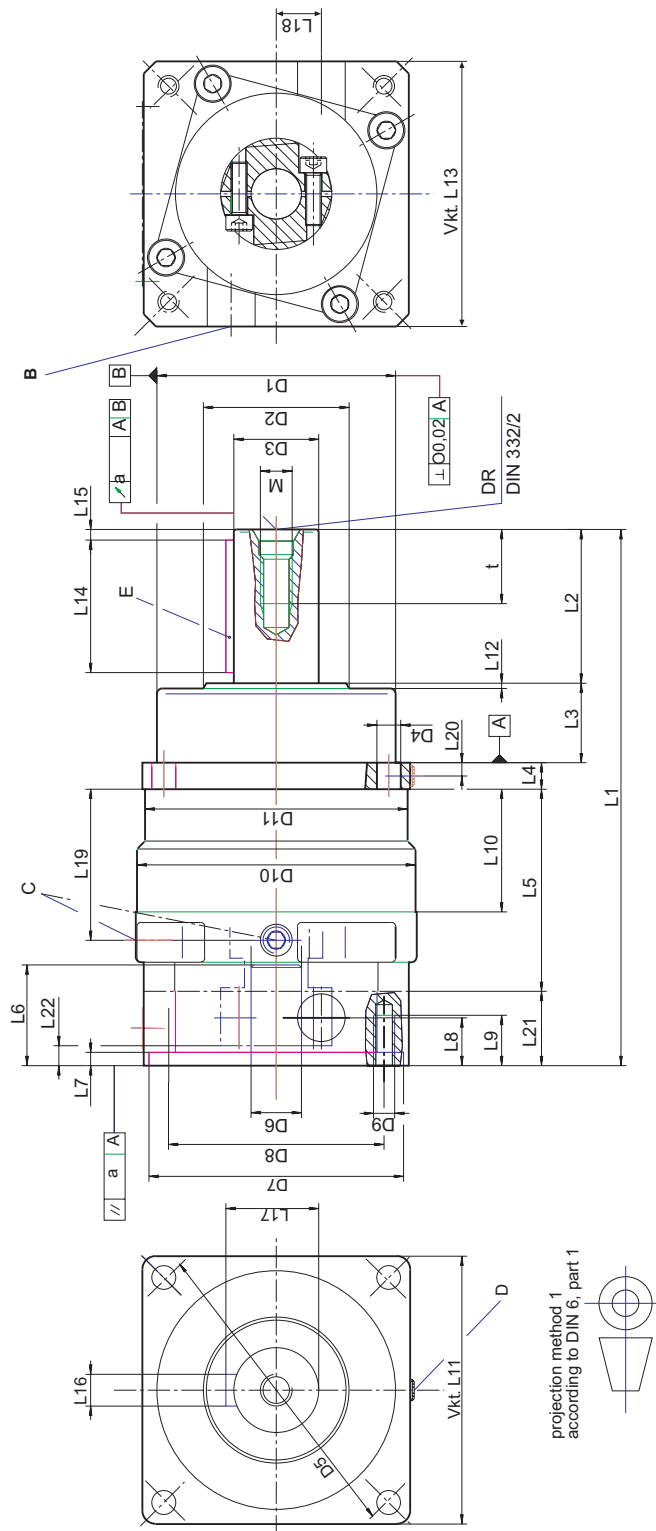

Fig. 6-32: Dimensional drawing of SP gearbox

Sizes SP 060 and SP 075

Size		SP 060		SP 075	
Number of gears		1	2	1	2
D1	g6	60	60	70	70
D2		30	30	38	38
D3	k6	16	16	22	22
D4	4x	5.5	5.5	6.6	6.6
D5		68	68	85	85
D6	F7	14	14	19	19
D7		measure depends on the motor			
D8		measure depends on the motor			
D9		measure depends on the motor			
D10		58.5	58.5	74	74
L1	+/- 2	129	149	156	182.5
L2		28	28	36	36
L3		20	20	20	20
L4		6	6	7	7
L5		60	80	71	97.5
L6	min. max.	15 30	15 30	23 40	23 40
L7	+0.5	4	4	4	4
L8		9.4	9.4	14	14
L9		9	9	12	12
L10		44	64	51	77.5
L11	+/- 1	62	62	76	76
L12		2	2	2	2
L13	+/- 1	60	60	80	80
L14*		25	25	32	32
L15		2	2	2	2
L16	h9	5	5	6	6
L17		18	18	24.5	24.5
L18**		10	10	12	12
L19		48.3	68.3	57	83.5
L20		-	-	-	-
a		0.025	0.025	0.025	0.025
B		8	8	15	15
C		1xM6	1xM6	1xM8x1	1xM8x1
D		-		-	
E		round-ended feather key according to DIN 6885 sheet 1, form A			
M		M5	M5	M8	M8
t		12.5	12.5	19	19

Table 6-26: Gearbox dimensions

* (on L14) In case of reversing operation and high gear strain, we recommend smooth drive shafts.

** (on L18) The dimensions may differ in case of very small motors.

Sizes SP 100, SP 140 und SP 180

Size		SP 100		SP 140		SP 180	
Number of gears		1	2	1	2	1	2
D1	g6	90	90	130	130	160	160
D2		55	55	70	70	90	90
D3	k6	32	32	40	40	55	55
D4	4x	9	9	11	11	13	13
D5		120	120	165	165	215	215
D6	F7	28	28	35	35	48	48
D7		measure depends on the motor					
D8		measure depends on the motor					
D9		measure depends on the motor					
D10		99	99	124	124	180	180
L1	+/- 2	202	234,5	256,5	296,5	297	315,5
L2		58	58	82	82	82	82
L3		30	30	30	30	30	30
L4		10	10	12	12	15	15
L5		76	108,5	102	142	132,5	158
L6	min. max.	30 50	30 50	32 60	32 60	45 82	45 82
L7	+0,5	5	5	6	6	6	6
L8		18	18	18	18	24,5	18
L9		19	19	21	21	25	21
L10		50	82,5	66,5	106,5	84,5	122,5
L11	+/- 1	101	101	141	141	182	182
L12		2	2	3	3	3	3
L13	+/- 1	100	100	140	140	190	140
L14*		50	50	70	70	70	70
L15		4	4	5	5	6	6
L16	h9	10	10	12	12	16	16
L17		35	35	43	43	59	59
L18**		17	17	19	19	26	19
L19		57	89,5	74,5	114,5	100,5	130,5
L20		5	5	6	6	12	12
L21		28	28	30,5	30,5	37,5	30,5
a		0,025	0,025	0,04	0,04	0,04	0,04
B		18	18	20	20	20	20

Size	SP 100		SP 140		SP 180	
C	3xM12x1,5		3xM12x1,5		3xM12x1,5	
D	1xM8x1		1xM8x1		1xM8x1	
E	round-ended feather key according to DIN 6885 sheet 1, form A					
M	M12	M12	M16	M16	M20	M20
t	28	28	36	36	42	42

Table 6-27: Gearbox dimensions

* (on L14) In case of reversing operation and high gear strain, we recommend smooth drive shafts.

** (on L18) The dimensions may differ in case of very small motors.



7 Appendix

7.1 Contact Addresses

For repair

Please send the components to be repaired or checked, along with the error report, to this address:

ELAU AG

Abt. Kundendienst	house address:
Postfach 1255	Dillberg 12
97821 Marktheidenfeld	97828 Marktheidenfeld
Phone: +49 (0) 93 91 / 606 - 142	
Fax: +49 (0) 93 91 / 606 - 340	

Service team

Should you need to talk to a member of our service team or require on-site service, please contact:

ELAU AG

Dillberg 12
 D-97828 Marktheidenfeld
 Phone: +49 (0) 93 91 / 606 - 0
 Fax: +49 (0) 93 91 / 606 - 300
 e-mail: info@elau.de
 Internet: www.elau.de

ELAU, Inc.

165 E. Commerce Drive
 Schaumburg, IL 60173 - USA
 Phone: +1 847 490 4270
 Fax: +1 847 490 4206
 e-mail: info@elau.com
 Internet: www.elau.com

ELAU SYSTEMS ITALIA S.r.l.

Via Tosarelli 300
 I-40050 Villanova di Castenaso (BO)
 Phone: +39 051 / 7818 70
 Fax: +39 051 / 7818 69
 e-mail: info@elau.it
 Internet: www.elau.it



NOTE

You find more contact addresses on the ELAU homepage (www.elau.de).

7.2 Further Literature

ELAU can provide you with these manuals and instructions on the PacDrive™ system:

Project Manual

Art. Nr. 17 13 00 58 - 00x (DE, EN, FR)

Programming Manual

Art. Nr. 17 13 00 61 - 00x (DE, EN)

Operating Manual PacDrive MC-4

Art. Nr. 17 13 00 62 - 00x (DE, EN, IT, FR)

Operating Manual CAN L2

Art. Nr. 17 13 00 66 - 00x (DE, EN)

Operating Manual PROFIBUS-DP

Art. Nr. 17 13 00 67 - 00x (DE, EN)

Operating Manual SM-Motor

Art. Nr. 17 13 00 68 - 00x (DE, EN, IT, FR)

Operating Manual EPAS-4

Art. Nr. 17 13 00 70 - 00x (DE, EN)

Operating Manual PacDrive Controller MAx-4

Art. Nr. 17 13 00 71 - 00x (DE, EN, IT, FR)

User Manual OPC-Server

Art. Nr. 17 13 00 73 - 00x (DE, EN)

Bedienungsanleitung Device Net

Art. Nr. 17 13 00 76 - 00x (DE, EN)

Bedienungsanleitung HMI Bibliotheken

Art. Nr. 17 13 00 77 - 00x (DE, EN)

Operating Manual INC-4 Incremental Encoder Module

Art. Nr. 17 13 00 78 - 00x (DE, EN)

Operating Manual CANopen

Art. Nr. 17 13 00 79 - 00x (DE, EN)

Operating Manual Motion Toolkit ECAM-4

Art. Nr. 17 13 00 80 - 00x (DE, EN)

Operating Manual PacNet Modul PN-4

Art. Nr. 17 13 00 81 - 00x (DE, EN)

Art. Nr. -000 DEutsch -001 ENGLISH -002 ITALIAN -003 FRENCH

Operating Manual SR-Motor

Art. Nr. 17 13 00 82 - 00x (DE, EN)

Operating Manual Bus Terminal BT-4/DIO1

Art. Nr. 17 13 00 83 - 00x (DE, EN)

Operating Manual TTS Training- and Testsystems

Art. Nr. 17 13 00 88 - 00x (DE)

Operating Manual Automatic Controller Optimization

Art. Nr. 17 13 00 89 - 00x (DE, EN)

Operating Manual PacDrive SCL

Art. Nr. 17 13 00 93 - 00x (DE, EN)

Operating Manual PacDrive PS-4 and PacDrive PD-8

Art. Nr. 17 13 00 94 - 00x (DE, EN)

User Manual Evaluation Kit

Art. Nr. 17 13 00 95 - 00x (DE)

Operating Manual PacDrive Controller P600

Art. Nr. 17 13 00 96 - 00x (DE)

Operating Manual PacDrive Controller C200

Art. Nr. 17 13 00 97 - 00x (DE, EN, FR)

Operating Manual PacDrive Controller C400

Art. Nr. 17 13 00 98 - 00x (DE, EN, FR)

Operating Manual PacDrive Controller C600

Art. Nr. 17 13 00 99 - 00x (DE, EN, FR)

Operating Manual PacDrive PC Panel PCP

Art. Nr. 17 13 01 02 - 00x (DE)

Operating Manual SH Motor

Art. Nr. 17 13 01 05- 00x (DE, EN)

7.3 Product Training

We offer practical workshops and seminars.

Our experienced seminar leaders will enable you to make optimum use of the vast possibilities of the PacDrive™ system.



NOTE

Please contact us for further information or to order our seminar program. See also our homepage (www.elau.de).

7.4 Declaration by the manufacturer

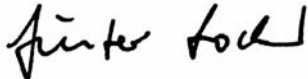
	<p align="center">Herstellereklärung / EC-Declaration by the manufacturer / CE-Déclaration du fabricant</p> <p align="center">im Sinne der EG-Maschinenrichtlinie 98/37/EG, Anhang II Abschnitt B as defined by EC-machinery directive 98/37/EC, Annexe II Section B conformément à la directive "CE" relative aux machines 98/37/CE Annexe II Section B</p>	<p align="center">ELN 119-01/09.98</p> <p align="center">page1/1</p>
<p>Das von uns gelieferte Produkt</p> <p>AC-Servomotor</p> <p>SM 070 SM 100 SM 140</p> <p>ist zum Einbau in eine Maschine bestimmt.</p> <p>Die Inbetriebnahme ist solange untersagt, bis festgestellt wurde, dass die Maschine, in die dieses Produkt eingebaut werden soll, den Bestimmungen der EG-Richtlinie entspricht.</p> <p>Hersteller:</p> <p>ELAU AG Dillberg 12 D-97828 Marktheidenfeld</p> <p>Stellung im Betrieb / Position :</p> <p>Vorstand/Chairman</p>  <p>15.9.1998 Günter Locherer (Datum, Date / Unterschrift, Signature)</p>	<p>The product delivered by our company</p> <p>AC-Servomotor</p> <p>SM 070 SM 100 SM 140</p> <p>is intended to be incorporated into a machine.</p> <p>The product must not be operated until the machine into which this product is to be incorporated has been declared in conformity with the provisions of the directive.</p> <p>Manufacturer:</p> <p>ELAU AG Dillberg 12 D-97828 Marktheidenfeld</p>	<p>Le produit livré par notre société</p> <p>AC-Servomotor</p> <p>SM 070 SM 100 SM 140</p> <p>est destiné à être installé dans une machine.</p> <p>La mise en service des composants est fortement déconseillée avant que la machine dans laquelle le produit sera installés n'ait été déclarée conforme aux dispositions de la directive.</p> <p>Fabricant:</p> <p>ELAU AG Dillberg 12 D-97828 Marktheidenfeld</p>

7.5 Modifications

01 / 1999

- SM motors run-up times, delay in lifting and delay in clamping revised
- New motors: SM 140 30 290 and SM 140 30 370

03 / 2000

- Insulation class is not H but F
- M_0 updated (as type plate datas)
- M_N is now shown in the Torque-Motor Speed Characteristics
- Stop Torque of the brake from the SM 070 is not 5 but 2,5 Nm
- New motors: SM 100 40 080 and SM 140 20 210
- Order numbers updated
- Sales regions updated
- Structure of the document modified
- „technical data in detail“ modified
- Various errors cleared and improvements made

01 / 2001

- Structure of the document modified
- Motors with surface ventilation new
- Order numbers updated
- Description of the encoder systems new
- Description of the holding brake widen
- Various errors cleared and improvements made

09 / 2002

- Structure of the document modified
- Changing to IP65 (casing and connection box)
- Various errors cleared and improvements made

07 / 2004

- product terms adjusted to new layout

10 / 2005

- barrier pressure system option new



NOTE

The latest documentation and modification service on this product are available on the ELAU Homepage (<http://www.elau.de>).

7.6 Index

- A**
admissible shaft strain 47
- B**
bearing 46
brake 14
 SM motor 51
- C**
connections
 SM motor 69
 X2 - motor 70
 X3 - brake / motor temperature 71
 X4 - encoder (Resolver) 73
 X4 - encoder (SinCos) 72
contact addresses
 ELAU AG 83
 ELAU Inc. 83
 ELAU SYSTEMS ITALIA S.r.l 83
- D**
definitions 38
dimensions
 gearbox 78
 SM motor 74
- E**
ELAU AG 2
eMail
 ELAU AG 2
EMC rules 25
encoder 14
 resolver 50
 SinCos 48
exchanging units 21
 exchange cable 23
 exchange motor 22
- F**
features 13
feedback 14
- H**
holding brake 14
 grind in 53
 SM motor 51
homepage
 ELAU AG 2
- I**
internet
 ELAU AG 2
- L**
literature 84
- M**
maintenance 19
manuals 84
Modifications 88
motor
 -feedback 14
 -shaft 46
- O**
Operating 84
operating manual 84
order numbers
 connector sets 36
 encoder cables 36
 motor cables 35
 SM motor 30
- P**
physical correlations 38
pictograph 8
Programmierhandbuch 84
- R**
repair 20, 83
risk
 classification 8
- S**
safety
 notes 8
sales regions 83
seminare 86
service
 -personnel 83

service addresses 20
shaft 14, 46
shaft strain 47
spare parts 19
storage 15

T

technical data 37
 SM 070 55
 SM 100 56
 SM 140 57
torque-speed characteristics
59
trademarks 2
training 86
transportation 15
type plate 16

U

unpacking 16
Use as directed 9

W

warning notes 8

7.7 Form for Error Report

This error report is absolutely necessary in order to enable efficient processing.

Send the error report to your ELAU representative or to:

ELAU AG, Abt. Kundendienst
Dillberg 12, D-97828 Marktheidenfeld
Fax: +49 (0) 93 91 / 606 - 340

Sender:

Company:	City:	Date:
Department:	Name:	Phone:

Details on the defective product

Product name:

Article number:

Serial number:

Software version:

Hardware code:

Parameter enclosed: yes [] no []

IEC program enclosed: yes [] no []

Details of the machine on which the problem occurred:

Machine producer:

Type:

Hours of operation:

Machine number:

Date of commissioning:

Producer/Type of machine control:
.....

Description of the problem:

.....
.....
.....

Additional information:

Problem state:

- persistent
- when commissioning
- occurs sporadically
- occurs after about.....hours
- occurs in case of shocks
- depends on temperature
- foreign object inside unit

Causes:

- unknown
- wiring error
- mechanical damage
- moisture inside the unit
- encoder defective

Concomitant phenomena:

- mechanical problems
- failure of mains supply (24V)
- failure of PMC-2
- motor failure
- broken cable
- insufficient ventilation

Does the switching cabinet have an air conditioning system?Y/N

Have similar problems occurred before on the same axis?

How often:

Did the problems occur on certain days or times of day?

.....
further information:
.....
.....
.....
.....
.....
.....
.....
.....
.....
.....
.....
.....
.....
.....
.....
.....
.....
.....
.....
.....
.....