

Receiving & Unpacking

Modular Power Distribution Unit

480 V with Auto-transformer (PDPM288G6H)

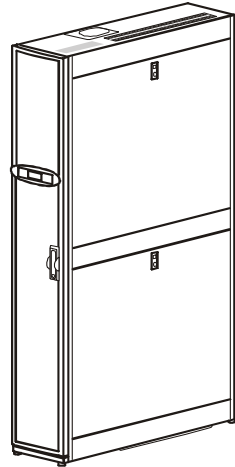

IMPORTANT SAFETY INSTRUCTIONS

Save these instructions. This guide contains information for receiving, unpacking, and moving the equipment.

⚠ WARNING

TIPPING/HEAVY EQUIPMENT HAZARD

- The unit is easily tipped. Use extreme caution when unpacking and moving the equipment.
- A minimum of two people are required to unpack and move the equipment.
- Ensure that the floor and sub-floor can support the total weight of the system, especially when the weight is concentrated on the stabilizing feet.

Failure to follow these instructions can result in death or serious injury.

Recyclable materials: The shipping materials are recyclable. Save them for later use, or dispose of them appropriately.

Receiving

External inspection

When the shipment arrives, inspect the shipping material for any signs of damage or mishandling. Do not attempt to install the Modular PDU if damage is apparent. If any damage is noted, file a damage claim with the shipping agency within 24 hours and contact Schneider Electric.

Compare the components of the shipment with the bill of lading. Report any missing items to the carrier and to Schneider Electric immediately.

Weights and Dimensions

	Weight (kg/lb)	Height (mm/in)	Width (mm/in)	Depth (mm/in)
Packaged	513/1130	2155/84.84	746/29.37	1181/46.49
Unpackaged	500/1100	2005/78.93	300/11.81	1095/43.11

Storage Conditions

Storage Temperature: -25° to +65°C/ -13° to +149°F	Relative Humidity: 0–95% Non-condensing	Altitude: 0–15000 m/0–50000 ft

Move to the Installation Site



Use a pallet jack or a forklift to move the Modular PDU. Make sure to lift only from the bottom. Do not use a forklift if the Modular PDU has been removed from its pallet.

NOTICE

- Leaving the equipment uncovered and exposed to the elements will cause damage and void the factory warranty.
- When possible, leave the equipment on the pallet until you are ready to move it to its final location.
- If the height of the enclosure exceeds the height of the doorway, remove the enclosure from the pallet.
- After the unit has been removed from the pallet, move it only by rolling it on the casters.
- Ensure that the floor is level. The unit must be installed on a level floor.

Space considerations

Position the unit on the far right end of a row to allow maximum access to internal components. Do not install the unit unless it is secured to adjacent equipment with the provided joining brackets.

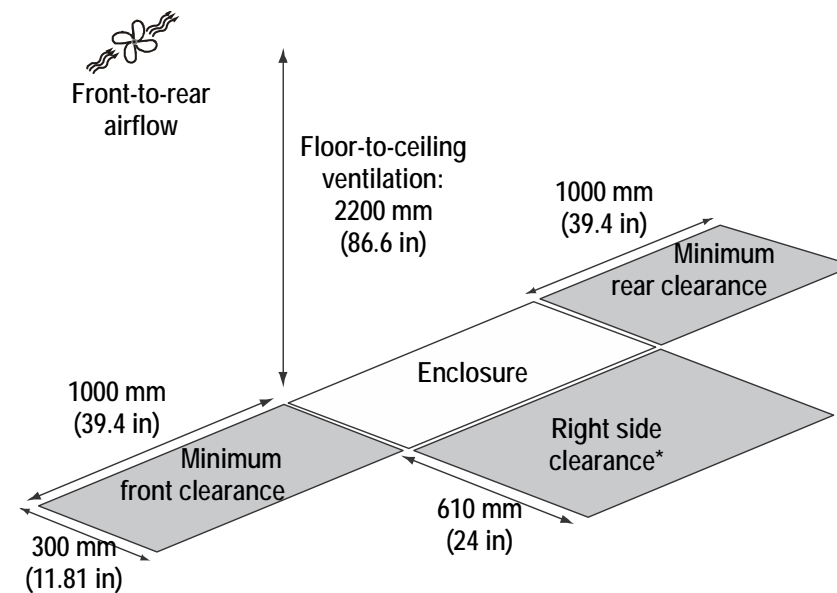

*Recommended for single/non-redundant PDU deployments.

Unpacking

If the system will not be installed immediately, do not remove the packaging. Store the system in an indoor, temperature-controlled area, free of conductive contaminants.



A minimum of two people are required to control the unit as it rolls down the ramp. One person should be on either side of the ramp. Ensure a clear area around the pallet and the ramp as an escape route in the event the unit were to tip over.

Tools Required (Not Provided)

Utility Knife	Level
17mm open ended wrench	13mm socket wrench

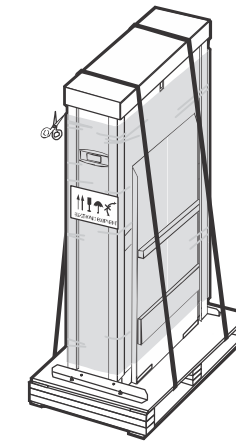

1 Cut the straps and the plastic wrap along the edges, and remove the plastic.

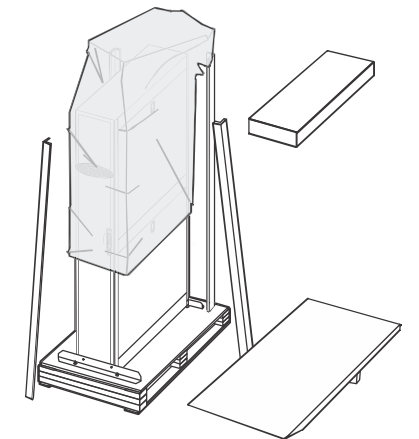

2 Remove the cardboard cover, the corner protection, and the plastic bag. Set the ramp aside.

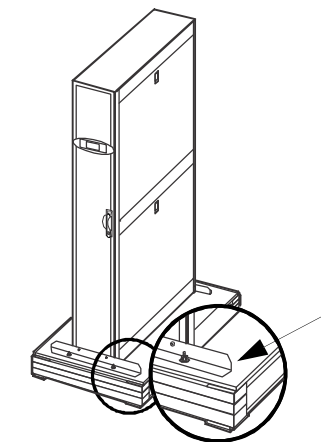

3 Remove the bolts securing the transport brackets to the pallet on the front and back of the Modular PDU.

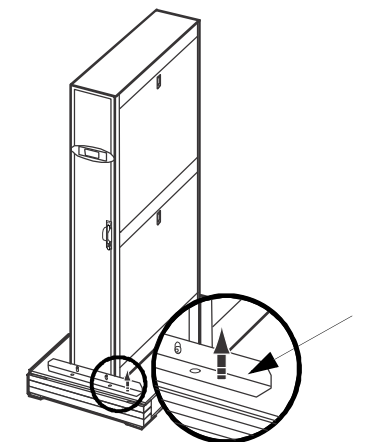

4 Loosen the bolts securing the transport brackets to the Modular PDU. Slide the brackets up and re-tighten the bolts.

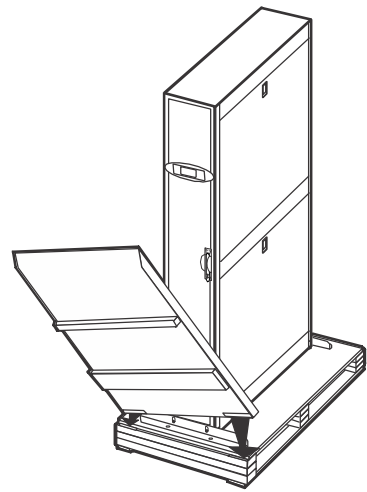

5 Align the hook-and-loop tape strips on the ramp to the front of the pallet.

7 Roll the Modular PDU to its final location.

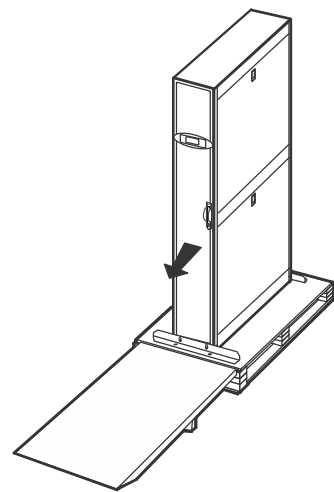

6 Roll the enclosure off the pallet.

8 Remove the transport brackets (see the drawing above step four).

Level the Modular PDU

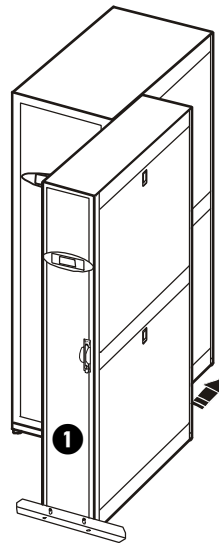

1 Roll the Modular PDU, rear-end first, into position flush against the adjacent equipment. Align the Modular PDU front with the front of the adjacent equipment. Use the front transport bracket as a guide.

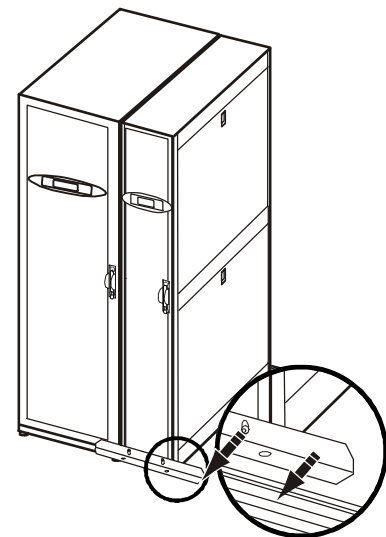

2 Remove the front transport bracket from the unit.

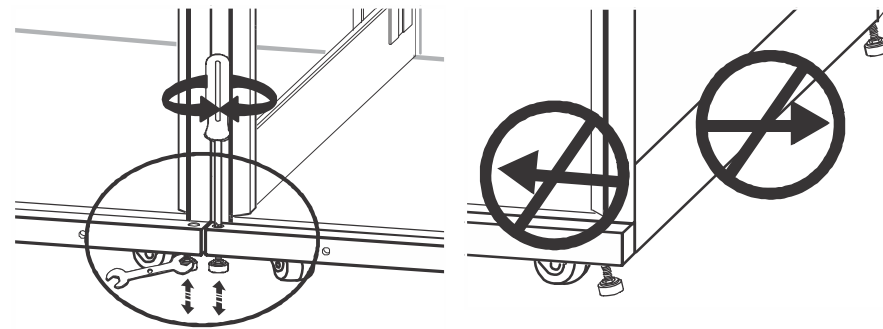

- 1 Use the supplied wrench to lower the four levelling feet to the floor.
- 2 You can also use a Phillips head screwdriver or drill bit inserted into the levelling feet screw heads.
- 3 Make adjustments to ensure the Modular PDU is completely level and properly aligned for joining with the adjacent equipment. The joining holes on both enclosures must be set on a horizontal plane.

⚠ WARNING

TIPPING/HEAVY EQUIPMENT HAZARD

Do not move the Modular PDU after its leveling feet have been lowered. This will cause the feet to buckle and may result in tipping. If the Modular PDU must be moved after this leveling process, raise the leveling feet until the casters again touch the floor and become the primary supports for the unit.

Failure to follow these instructions can result in death or serious injury.

Join the Modular PDU in the row

- 1 Open the front and the rear doors.

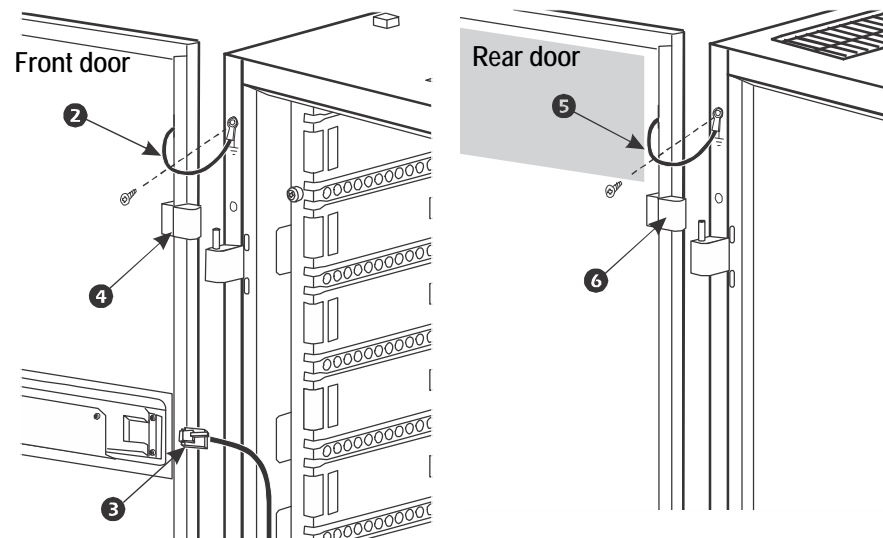

- 2 Disconnect the ground wire on the front door.
- 3 Disconnect the display interface cable.
- 4 Lift the front door from its hinges to remove the door.
- 5 Disconnect the ground wire on the back door.
- 6 Lift the back door from its hinges to remove the door.

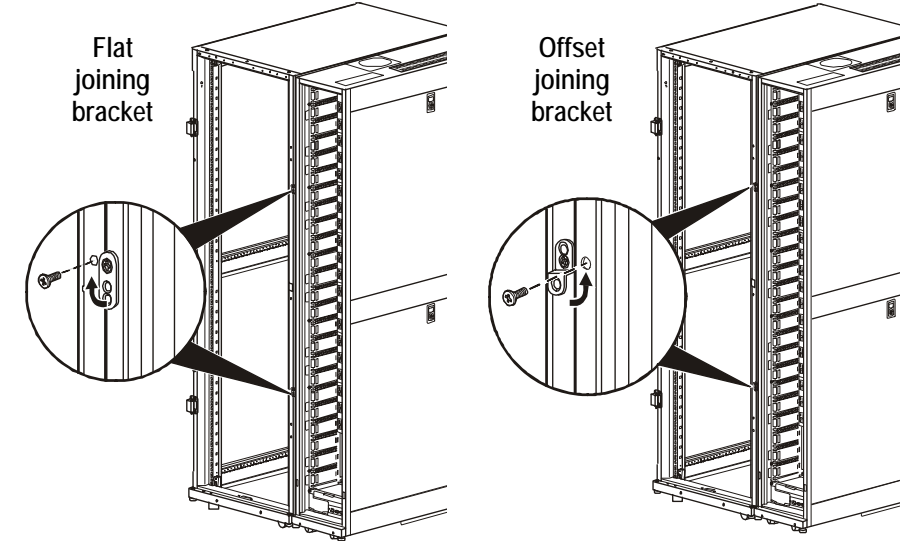

- 7 Install two joining brackets, flat or offset as required, between the Modular PDU and the adjacent equipment. Joining brackets and screws are provided with the unit.
- 8 Replace the doors and connect the ground wires and display interface cable.

Documentation Storage

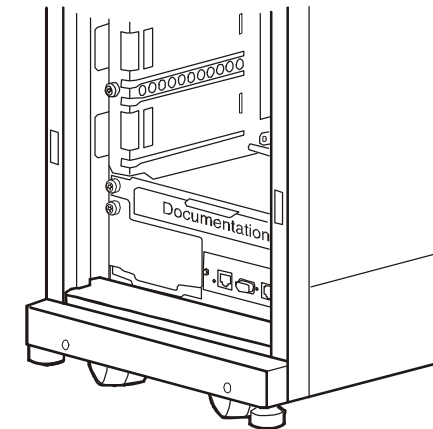

The manuals for the Modular PDU can be placed in the documentation tray inside the enclosure.

Worldwide Customer Support

Go to www.schneider-electric.com/support for Warranty information and Customer Support.

© 2014 Schneider Electric. All rights reserved.