

Mx51/61-720x Two-Position, Floating, and Proportional Series

SmartX Actuators Linear Spring Return

Application

Linear MA, MF and MS 51- and 61-720x SmartX Actuators are designed to mount directly onto two-way or three-way valves. They provide linear travel to economically operate 1¼" to 2" VB-7xxx, 2½" to 5" VB-8xxx, 2½" to 4" VB-931x, and discontinued 1½" to 4" VB-9xxx valves in hot water, chilled water, and steam applications up to 366°F (186°C) fluid temperature.

The linear spring return actuators provide either two position, floating or proportional modulation control (depending on model selection) of valves in HVAC systems.

Features

- Two position models controlled by SPST controller
- Floating models controlled by SPDT floating controllers
- Proportional models controlled by 2-10 Vdc, or 4-20 mAdc with the addition of a 500 ohm resistor. Control function direct/reverse action is switch selectable
- 220 lb force (979 newton) with ½" (13 mm) or 1" (25 mm) nominal linear stroke
- Automatically sets control signal input span to match valve travel
- 24 Vac, 120 Vac, and 230 Vac models
- Rugged die-cast enclosures rated for NEMA 2, UL Type 2/ IP54
- Overload protection throughout stroke
- Compact size for application flexibility
- Manual override to allow positioning of valve and preload
- Integral linkage for direct mount to valves
- Five year warranty

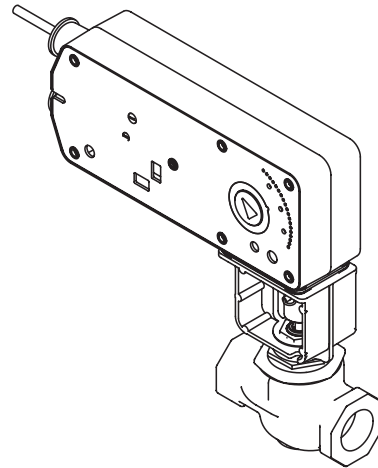

Mx51-720x

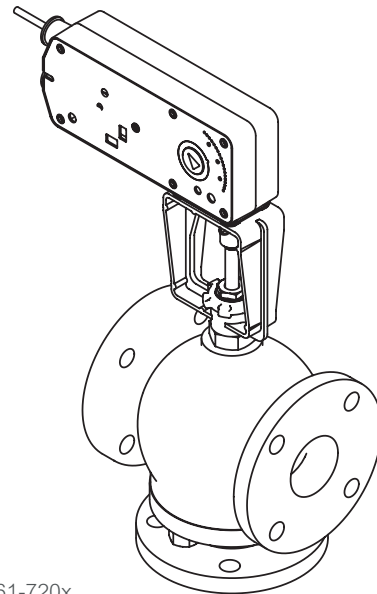

Mx61-720x

Applicable Literature

F-27165	Linear Spring Return SmartX Actuators Submittal Sheet
F-27167	Two-Way and Three-Way Globe Valve Assemblies with SmartX Linear Series Spring Return Actuators Submittal Sheet
F-26080	EN-205 Water System Guidelines
F-27252	Vx-7xxx, Vx-9xxx Series Linked Globe Valves with Linear SmartX Actuators Selection Guide
F-27199	Vx-8xxx Valve Selection Guide
F-27203	AM-731, AM-732, AM-733, AM-734, Kit General Instructions
F-26075	VB-7213 Series ½"...2" Screwed NPT, Stem Up Open, Two-Way Valves, General Instructions
F-25675	VB-7214 Series ½"...2" Union Sweat, Solder Joint Stem Up Open, Two-Way Valves, General Instructions
F-26077	VB-7215 Series 15 mm to 50 mm Screwed Rp, Stem Up Open, Two-Way Valves, General Instructions
F-26073	VB-7223 Series ½"...2" Screwed NPT, Stem Up Closed, Two-Way Valves, General Instructions
F-24387	VB-7224 Series ½"...2" Union Sweat, Solder Joint Stem Up Closed, Two-Way Valves, General Instructions
F-26079	VB-7225 Series 15 mm to 50 mm Screwed Rp, Stem Up Closed, Two-Way Valves, General Instructions
F-24388	VB-7253 Series ½"...2" Screwed NPT, Stainless Steel Trim with Teflon Disc, Stem Up Open, Two-Way Valves, General Instructions
F-24389	VB-7263 Series ½"...2" Screwed NPT, Stainless Steel Trim with Teflon Disc, Stem Up Closed, Two-Way Valves, General Instructions
F-24390	VB-7273 Series ½"...2" Screwed NPT, Stainless Steel Trim, Stem Up Open, Two-Way Valves, General Instructions
F-24391	VB-7283 Series ½"...2" Screwed NPT, Stainless Steel Trim, Stem Up Closed, Two-Way Valves, General Instructions
F-26074	VB-7313 Series ½"...2" Screwed NPT, Three-Way Mixing Valves, General Instructions
F-24394	VB-7314 Series ½"...2" Union Sweat, Solder Joint, Three-Way Mixing Valves, General Instructions
F-26078	VB-7315 Series 15 mm to 50 mm Screwed Rp, Three-Way Mixing Valves, General Instructions
F-26076	VB-7323 Series ½"...2" Screwed NPT Three-way Diverting Valves, General Instruction
F-27193	VB-8213 Series 2½" to 6" Flanged, Stem Up Open, Two-Way Valves, General Instructions
F-27194	VB-8223 Series 2½" to 6" Flanged, Stem Up Closed Two-Way Valves, General Instructions
F-27197	VB-8303 Series 2½" to 6" Flanged, Three-Way Diverting/Mixing Valves, General Instructions
F-24382	VB-9213 Series, 2½" and 3" Screwed NPT, 2½" to 6" 125 Lb. Flanged, Stem Down to Close Two-Way Valves, General Instructions
F-25672	VB-9215 Series, 65 mm and 80 mm Screwed R _p , Stem Down to Close Two-Way Valves, General Instructions
F-24386	VB-9223 Series, 2½" and 3" Screwed NPT, 2½" to 6" 125 Lb. Flanged, Stem Up to Close Two-Way Valves, General Instructions
F-25673	VB-9225 Series, 65 mm and 80 mm Screwed R _p , Stem Up to Close Two-Way Valves, General Instructions
F-24393	VB-9313 Series, 2½" and 3" Screwed NPT, 2½" to 6" 125 Lb. Flanged, Three-Way Mixing Valves, General Instructions
F-25674	VB-9315 Series, 65 mm and 80 mm Screwed R _p , Three-Way Mixing Valves, General Instructions

Specifications

Actuator Inputs	All 24 Vac circuits are Class 2. All circuits 30 Vac and above are Class 1.		Environment		
Control Signal	On-off spring return, SPST control contacts or Triacs (500mA rated).		Ambient Temperature Limits	-40...160 °F (-40...71 °C)	
MAx1-720x	Floating point, SPDT control contacts or Triacs (500 mA rated) 24 Vac.		Shipping & Storage	0...140 °F (-18 to 60 °C)	
MFx1-7203	Proportional: 2...10 Vdc or 4...20 mAdc with 500 W resistor.		Operating	0...140 °F (-18 to 60 °C)	
MSx1-7203			Temperature Restrictions		
Power Input	Vac ± 20%, 22...30 Vdc, 120 Vac ± 10%, 230 Vac ± 10%, 50/60 Hz.		Actuator	Max. Allowable Ambient @ Max. Fluid Temperatures	Valve Body
MAx1-720x-24	Vac ± 20%, Class 2, 22...30 Vdc.		Mx51-720x	140 °F (60 °C) @ 281 °F (138 °C) 120 °F (49 °C) @ 300 °F (149 °C) 100 °F (38 °C) @ 340 °F (171 °C) 90 °F (32 °C) @ 366 °F (186 °C)	VB-721x, 722x VB-73xx VB-725x, 726x VB-727x, 728x
MFx1-7203, MSx1-7203-24	3 ft (91 cm) appliance cables, ½ inch (13 mm) conduit connectors For M20 Metric conduit, use AM-756 adaptor		Mx61-720x	140 °F (60 °C) @ 300 °F (149 °C)	2½" ...4" VB-931x
Connections			Mx61-720x	140 °F (60 °C) @ 281 °F (138 °C)	2½" ...5" VB-8xx3, 2½" to 4" VB-92xx
Actuator Outputs			Humidity	15...95% RH, non-condensing.	
Electrical			Enclosure Rating	NEMA1. NEMA 2, UL Type 2 (IEC IP54) with customer supplied watertight conduit connectors.	
Position Feedback Voltage (proportional only):	MSx1-7203: 2...10 Vdc (max. 0.5 mA) output signal for position feedback or to operate up to four additional slave actuators		Agency Listings	UL 873 Underwriters Laboratories (File #E9429 Category Temperature-Indicating and Regulating Equipment).	
Mechanical			CUL	UL Listed for use in Canada by Underwriters Laboratories. Canadian Standards C22.2 No. 24-93.	
Motor Type	Brushless DC		European Community	EMC Directive (89/336/EEC). Low Voltage Directive (72/23/EEC)	
Linear Stroke (Nominal)	Mx51-720x-½" (13 mm) Mx61-720x-1" (25 mm)		Australia	This product meets requirements to bear the RSM Mark according to the terms specified by the Communications Authority under the Radiocommunications Act 1992.	
Approx. Stroke Timing	100 seconds for ½" stroke. 190 seconds for 1" stroke.				
Manual Override	Allows positioning of valve and preload using manual crank				
Right/Left Switch	Permits reverse acting/direct acting linear motion (MSx1 only)				

The specifications conform to acceptable industry standards. For applications at conditions beyond these specifications, consult your local Schneider Electric representative office. Schneider Electric shall not be liable for damages resulting from misapplication or misuse of its products.

Table 1. Specifications

Part Number	Control Action	Actuator Power Input							Linear Stroke Inches	Approximate Stroke Timing in Seconds @ 70°F (21°C)		Output Force Rating lb. (Newton)		Valve Size					
		Voltage	Running				DC Amps	50/60 Hz		Powered	Spring Return	Min.	Max. Stall						
			50 Hz	60 Hz		W													
			VA	W	VA	W	W												
MA51-7203	2 Position	24 Vac ±20% 22...30 Vdc	9.8	7.5	9.7	7.5	.29	2.8	5/8	<100	<35	220 (979)	495 (2202)	1¼"...2"					
MA51-7200		120 Vac ±10%	11.7	8.8	10.0	8.4	N/A	3.6/5.0											
MA51-7201		230 Vac ±10%	15.5	9.5	10.6	8.5		4.6/3.3											
MA61-7203		24 Vac ±20% 22...30 Vdc	9.8	7.5	9.7	7.5	.29	2.8	1-1/16	<190	<40				220 (979)	495 (2202)	2½"...4" c or 5"		
MA61-7200		120 Vac ±10%	11.7	8.8	10.0	8.4	N/A	3.6/5.0											
MA61-7201		230 Vac ±10%	15.5	9.5	10.6	8.5		4.6/3.3											
MF51-7203	Floating	24 Vac ±20% 22...30 Vdc	9.8	7.7	9.7	.30	3.3	5/8	<100	<35	220 (979)	495 (2202)	1¼"...2" b						
MF61-7203								1-1/16	<190	<40				2½"...4" or 5" c					
MS51-7203	Proportional							7.4	7.4	.28								2.9	5/8
MS61-7203				1-1/16										<190	<40	2½"...4" or 5" c			

- a - Timing was measured with no load applied to the actuator.
- b - Current VB-7xxx series valves and discontinued 1¼" VB-9xxx series valves.
- c - Current VB-931x Series valves (2½"...4"), current VB-8xx3 (2½"...5") Series valves, and discontinued VB-9xxx (1½"...4") Series valves.

Accessories

- AM-763 1/8" Hex crank for manual override
- AM-756 Metric conduit adapter M20 x 1.5 to ½" NPT
- AM-731 Mounting kit - Mx51-720x (stem extension, lock washer, jam nut, and connecting pin; included with actuator)
- AM-732 Mounting kit - Mx61-720x (stem extension, lock washer, jam nut, and connecting pin; included with actuator)
- AM-733 Retrofit kit - discontinued VB-9xxx 1½"...2" valves after 9404 date code
- AM-734 Retrofit kit - discontinued VB-9xxx 1½"...2" valves prior to 9404 date code

MSx1-7203

- AM-703 Input rescaling module, adjust signals to 2...10 Vac, zero and span adjust
- AM-704 Interface, pulse width modulation (PWM)
- AM-705 Positioner (NEMA 4 housing)
- AM-706 Min and/or manual positioner for flush panel mount
- AM-708 500 Ω resistor for 4...20 mAdc control signal

Close-Off Pressure and Maximum Operating Pressure Differential

For all valve assemblies, be sure to check that the anticipated maximum pressure drop across the valve in the closed position will not exceed the close-off pressure rating and that the pressure differential across the valve will not exceed the maximum operating pressure differential rating. For VB-7xxx and VB-9xxx valve applications, consult the Vx-7xxx & Vx-9xxx Selection Guide, F-27252. For VB-8xx3 valve applications, consult the Vx-8xxx Selection Guide, F-27199.

Wiring

Typical Two Position Control

Figure 1 illustrates typical wiring diagrams for spring return MAx1-720x Series spring return two-position actuators. See Table 1 for model selection.

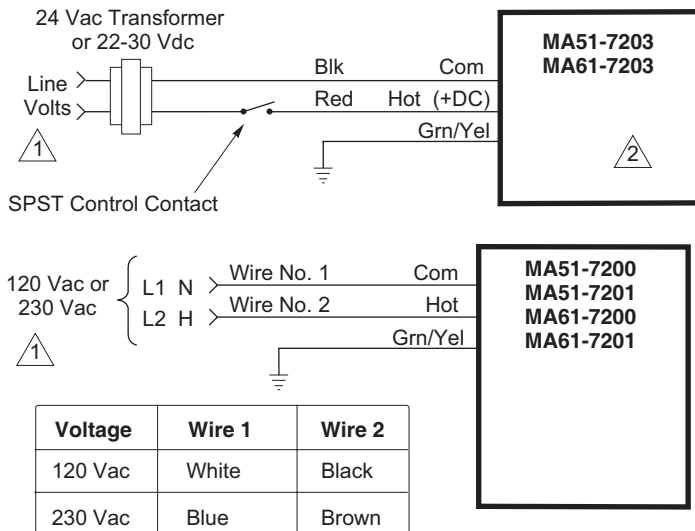

- 1 Provide overload protection and disconnect as required.
- 2 Actuators mounted on separate valves may be wired in parallel. Power supply black wires are connected to the transformer common and power supply red wires are connected to the hot lead. Power consumption must be observed.

Figure 1. Typical Wiring Diagrams for Two Position Actuators.

Typical Floating Control

Figure 2 through Figure 5 illustrate typical wiring diagrams for MFx1-7203 Series spring return floating actuators. See Table 1 for model selection.

Caution: This product contains a half-wave rectifier power supply and must not be powered off transformers used to power other devices utilizing non-isolated full-wave rectifier power supplies. Refer to EN-206, Guidelines for Power Multiple Devices from a Common Transformer, F-26363 for detailed information.

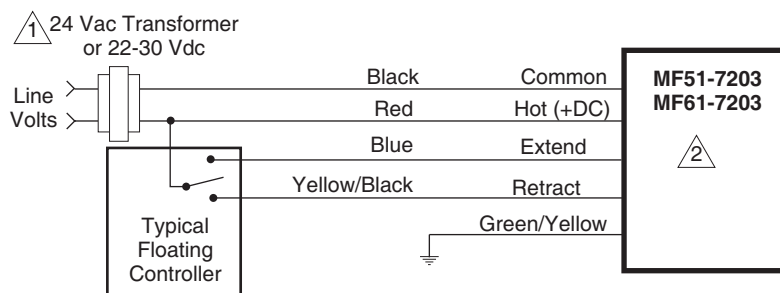

- 1 Provide overload protection and disconnect as required.
- 2 Actuators may be wired in parallel. All actuator black wires are connected to the transformer common and all red wires are connected to the hot lead. Power consumption must be observed.

Figure 2 Floating Point Control.

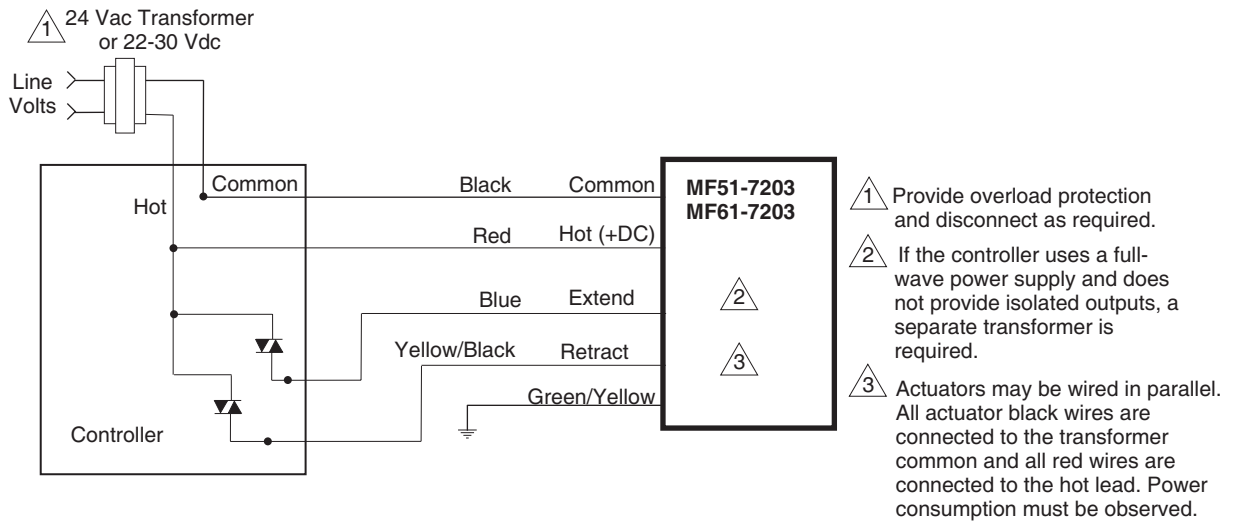

Figure 3 Triac Source.

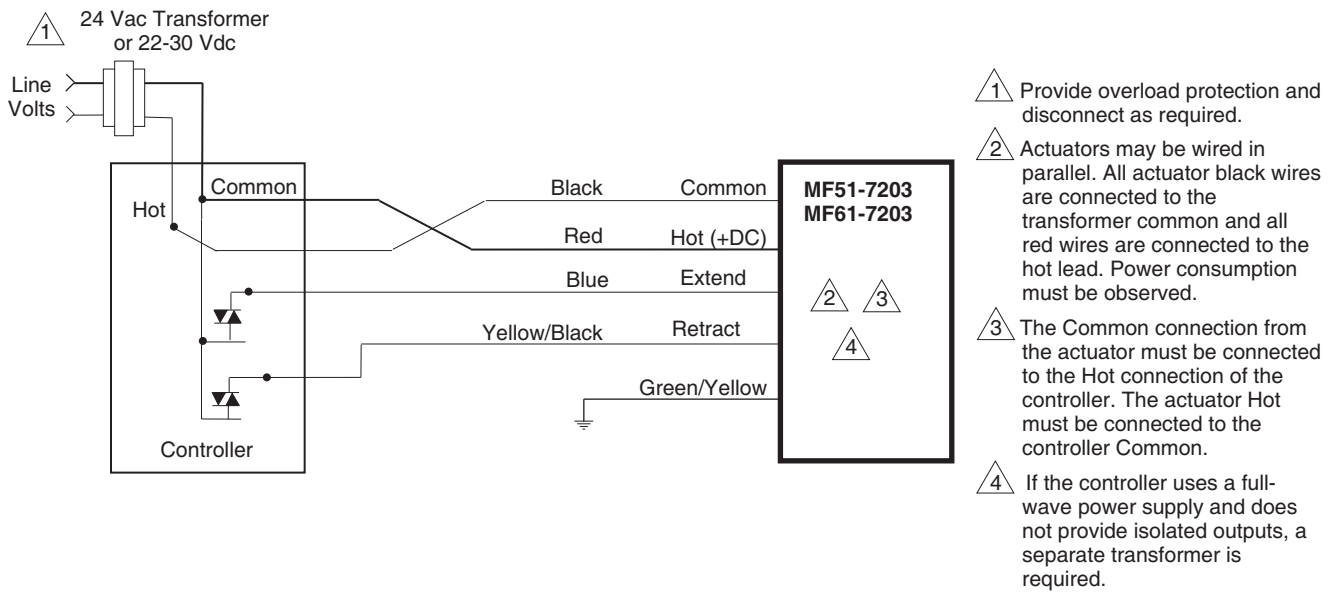

Figure 4 Triac Sink

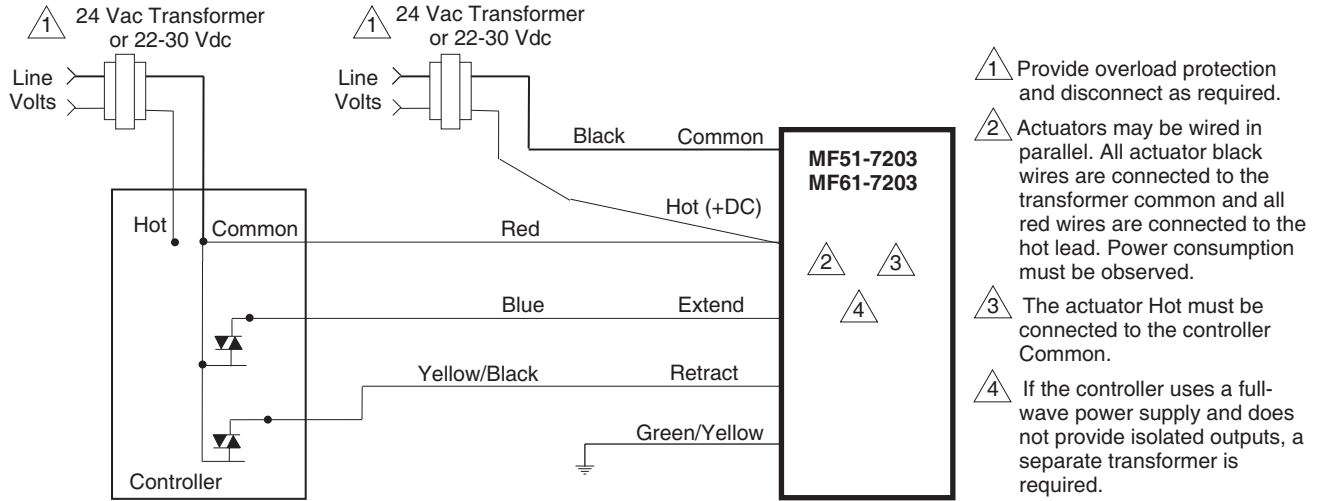
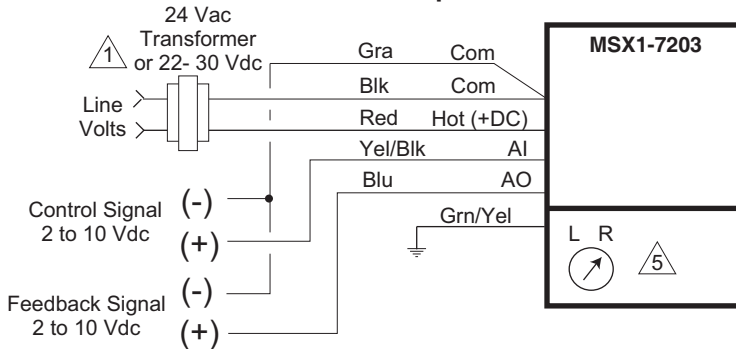

Figure 5 Triac Sink With Separate Transformers.

Figure 6 illustrates typical wiring diagrams for MSX1-7203 Series proportional spring return actuators. See Table 1 for model selection.

Caution: This product contains a half-wave rectifier power supply and must not be powered off transformers used to power other devices utilizing non-isolated full-wave rectifier power supplies. Refer to EN-206, Guidelines for Powering Multiple Devices from a Common Transformer, F-26363 for detailed information.

2 to 10 Vdc Proportional Control



4 to 20 mAdc Proportional Control

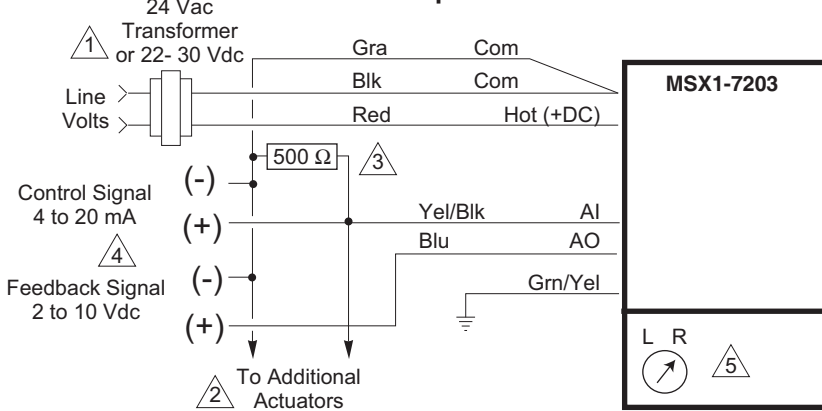

- 1** Provide overload protection and disconnect as required.
- 2** With four actuators wired to one 500 ohm resistor, a +2% shift of the control signal may be required. (Actuator input impedance is 80 k ohm.)
- 3** A field-supplied 500 ohm resistor (AM-708) is required between the gray and yellow/black leads to convert the 4 to 20 mAdc control signal to 2 to 10 Vdc.
- 4** Only connect common to negative (-) leg of control circuits.
- 5** To reverse actuator control function (direct/reverse action), use the reversing switch, see Figure-9.

Figure 6 Typical Wiring Diagrams for Proportional Control 24 Vac Basic Models.

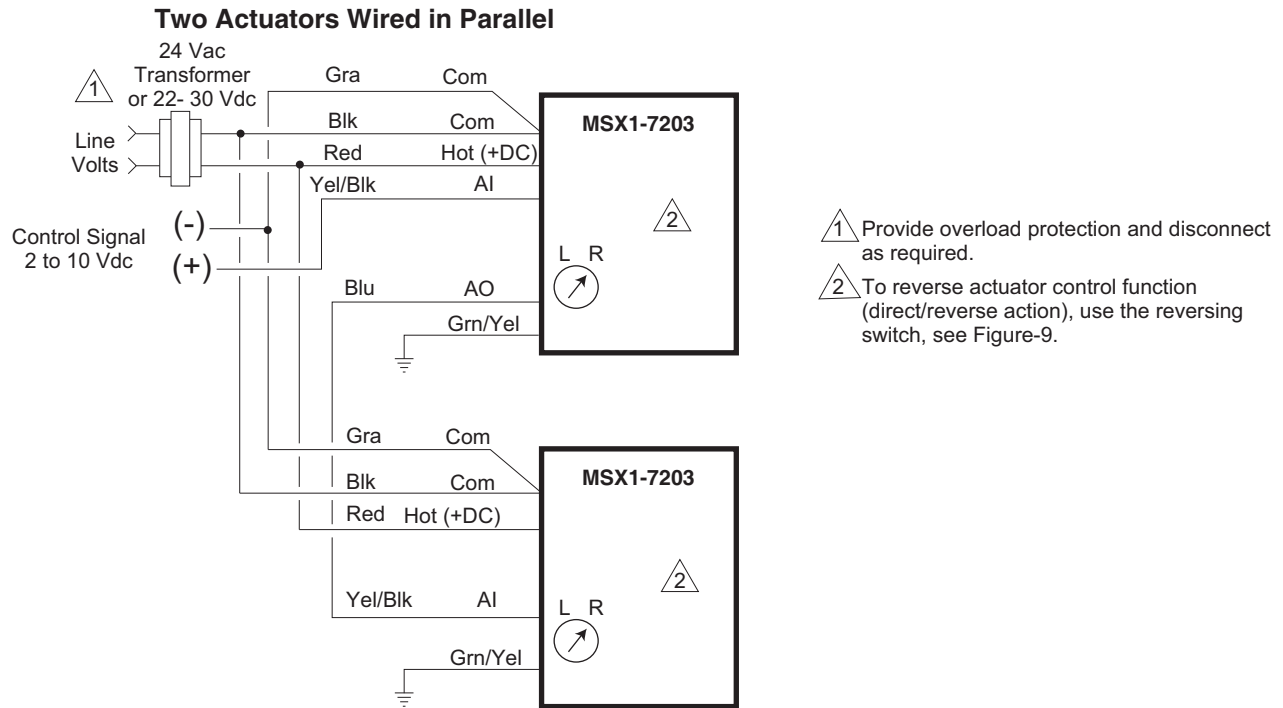

Figure 7 Typical Wiring Diagrams for Proportional Control 24 Vac Models Wired in Parallel.

Installation

Inspection

Inspect the package for damage. If damaged, notify the appropriate carrier immediately. If undamaged, open the package and inspect the device for obvious damage. Return damaged products.

Requirements

- Job wiring diagrams
- Appropriate accessories
- Pliers for removing and inserting connecting pin
- Installer must be a qualified, experienced technician
- Tool-37, 1½" ... 3" adjustable spanner wrench for valve mounting nut
- 5/16" (Tool-20-1) and 3/4" open-end wrench for stem jam nuts
- 1/8" Allen wrench
- Size 10 IP Torx Plus bit (Mx51 units only)

Precautions

- Electrical shock hazard. Disconnect the power supply (line power) before installation to prevent electric shock and equipment damage.
- Make all connections in accordance with the job wiring diagram and in accordance with national and local electrical codes.
- Use copper conductors only.
- Floating and Proportional Models: These products contain a half-wave rectifier power supply. They must not be powered with transformers that are used to power other devices utilizing non-isolated full-wave rectifier power supplies. Refer to EN-206, Guidelines For Powering Devices From A Common Transformer, F-26363 for detailed information.
- Avoid electrical noise interference.
- Do not install near large contactors, electrical machinery, or welding equipment.
- Manual override to be used only when power is not applied to unit.
- When operating manual override (observe position indicator, Figure 8), back off 5° (½ turn counter clockwise) from full extended mechanical stop to ensure proper release.

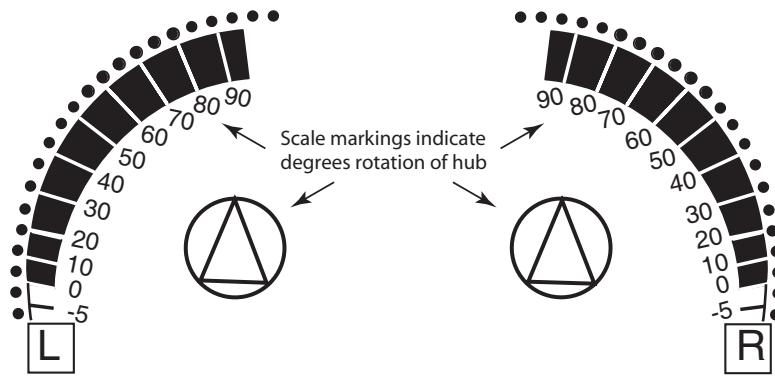

Figure 8 Position Indicator

- Do not drill holes in actuator body. Six pre-drilled holes are located on each side, under crosshairs on the label, to accept #10-24 thread-forming screws for mounting accessories.

Federal Communications Commission (FCC)

This equipment has been tested and found to comply with the limits for a Class B digital device, pursuant to Part 15 of the FCC Rules. These limits are designed to provide reasonable protection against harmful interference in residential installations. This equipment generates, uses, and can radiate radio frequency energy and may cause harmful interference if not installed and used in accordance with the instructions. Even when instructions are followed, there is no guarantee that interference will not occur in a particular setting—Which can be determined by turning the equipment off and on—the user is encouraged to try to correct the interference by one or more of the following measures:

- Reorient or relocate the receiving antenna.
- Increase the separation between the equipment and receiver.
- Connect the equipment to an outlet on a circuit different from that to which the receiver is connected.
- Consult the dealer or an experienced radio/television technician for help.

Canadian Department of Communications (DOC)

This Class B digital apparatus meets all requirements of the Canadian Interference-Causing Equipment Regulations.
Cet appareil numérique de la classe B respecte toutes les exigences du Règlement sur le matériel brouilleur du Canada.

European Standard EN 55022

This is a Class B digital (European Classification) product. In a domestic environment this product may cause radio interference in which case the user may be required to take adequate measures.

Location

Avoid locations where excessive moisture, corrosive fumes, vibration, or explosive vapors are present.

Mounting

- Mount the linear actuator directly on the valve in locations that clear the maximum dimensions of the actuator case (see Figures 19 and 20).
- Ensure that the valve body is installed correctly. The arrow must point in the direction of flow. With three-way valves observe stem position (stem up) for proper flow characteristics. See Table 2.
- The actuator must be mounted above the centerline of the valve body. This will minimize the risk of damage to the actuator in the event of condensation. Refer to Figure 15, Figure 16, and Figure 17.

Actuator Selection

Mx51 series actuators are used on 1¼"…2" VB-7xxx valves. Mx61 series actuators are used on 2½" to 4" VB-931x, 2½" to 5" VB-8xxx, and discontinued 1½" to 4" VB-9xxx valves (with AM-733 or AM-734kit purchased separately).

Changing Control Function (proportional units only)

These actuators are equipped with a switch to control the function of the signal as received. See Figure 9.

Caution: These are spring return actuators. It is possible to switch to a direction that moves the actuator against the -5° positive stop. Example: Viewing the actuator from the left side with the switch set to "R" and an increasing signal. The actuator will attempt to rotate beyond the -5° stop and will stall.

- Install all two-way valves so that they close against the flow. An arrow on the valve body or a tag indicates the proper flow direction.
- Always install three-way mixing valves with two inlets and one outlet.
- Install three-way diverting valves with one inlet and two outlets. When piped for mixing, Cv's may differ slightly.

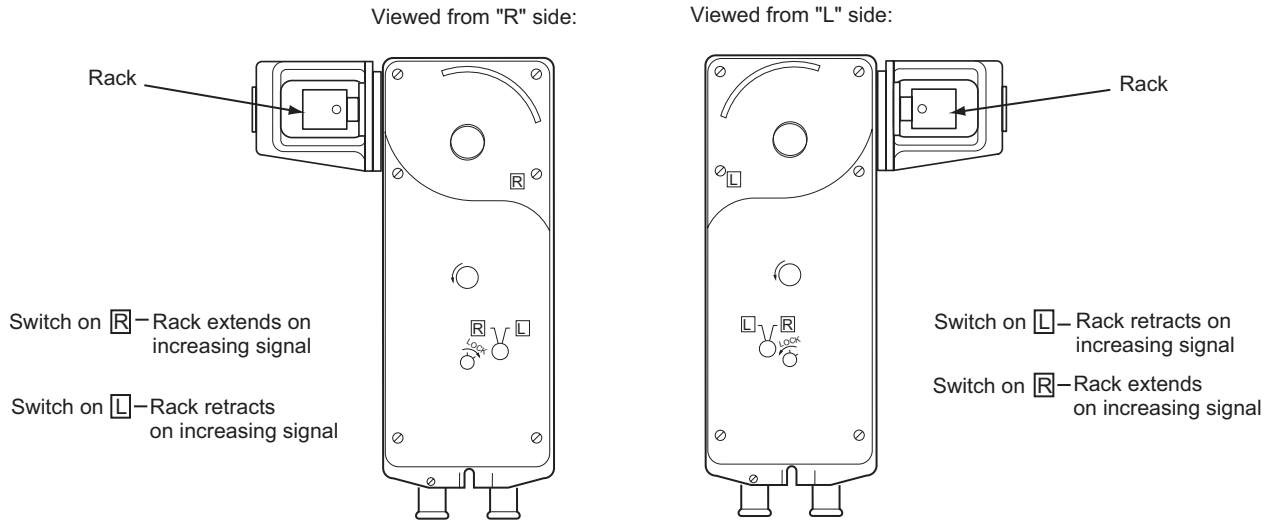

Figure 9 Rotation Switch Settings for MSx1-7203 Proportional Actuators.

Table 2 Valve Configuration Chart.

Valve Body	Valve Body Action	Normal Position		Action
		Valve Stem	Flow	
VB-721x VB-7253 VB-7273 VB-821x VB-921x	Two-Way Stem Up Open	Up	Open	Port A to AB flow decreases as actuator extends
VB-722x VB-7263 VB-7283 VB-822x VB-922x ^a	Two-Way Stem Up Closed	Up	Closed	Port A to AB flow increases as actuator extends
VB-731x VB-931x	Three-Way Mixing	Up	B to AB	Port A to AB flow increases as actuator extends Port B to AB flow decreases as actuator extends
VB-732x	Three-Way Diverting	Up	B to AB	Port B to A flow increases as actuator extends Port B to AB flow decreases as actuator extends
VB-8303	Three-Way Piped as Mixing	Up	AB to B	Port A to B flow increases as actuator extends Port AB to B flow decreases as actuator extends
VB-8303	Three-Way Piped as Diverting ^b	Up	B to AB	Port B to A flow increases as actuator extends Port B to AB flow decreases as actuator extends

a - Discontinued.

b - Universal diverting/mixing valve, may be piped as either mixing or diverting.

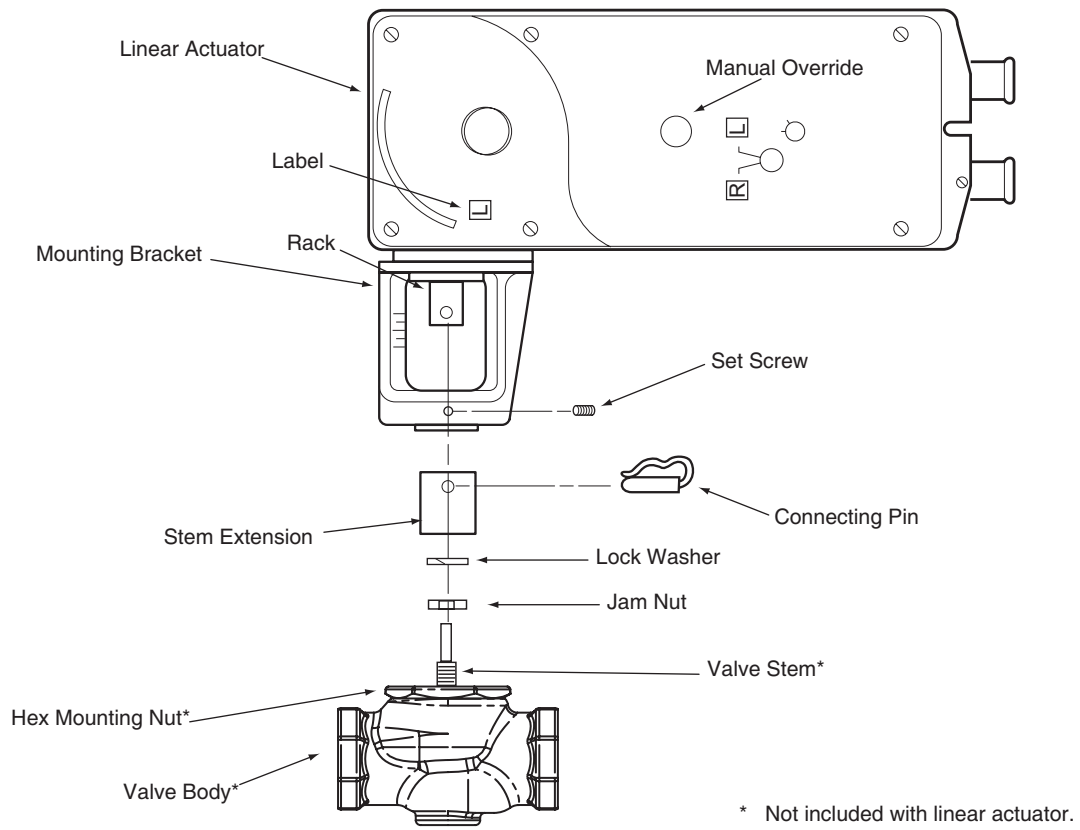

Figure 10 Mx51-720x Series Actuator Exploded View.

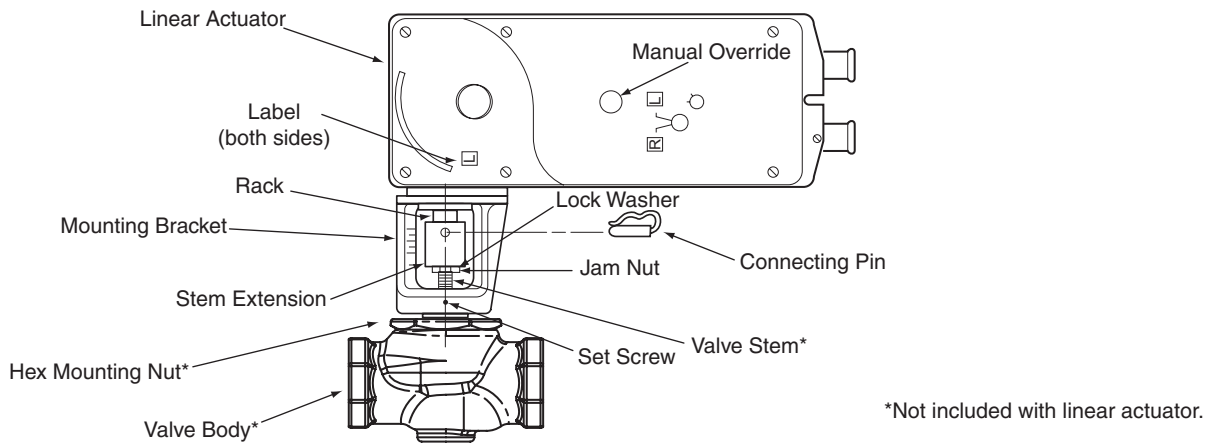

Figure 11 Typical Assembly and Installation of Mx51 Series Actuator to 1¼" to 2" VB-7xxx Series Valve Bodies, Stem-Up Closed or Open, 2-Way and 3-Way Valves.

Installation

Mx51-720x Series Actuator to 1¼" to 2" VB-7xxx Series Valve Bodies, Stem-Up Closed or Open, 2-Way and 3-Way

1. Install the actuator onto the valve. Set up the assembly according to the numbered steps in Figure 11.
 - a. Locate the jam nut that came packaged with the actuator.
 - b. Screw the jam nut onto the valve stem all the way as far as it will go. You may need to use a 5/16" (Tool-20-1) open-end wrench. At least ½" of the valve stem threads should extend above the nut.
 - c. Place lock washer over valve stem.
 - d. Thread the stem extension onto the valve stem, making contact with the lock washer and jam nut.
 - e. Ensure 15° or 1½ turns of manual override for actuator preload. See Figure 18.
 - f. Orient the actuator mounting bracket on the valve and tighten the mounting nut securely against the bracket using Tool-37. Raise the valve stem to the full up position.
 - g. Rotate stem extension until the through hole lines up with the through hole of actuator rack. Insert connecting pin to secure stem extension and tighten jam nut against stem extension using 5/16" (Tool-20-1) open end wrench.
 - h. Affix open/closed label to the indicator in the appropriate position.
 - i. Insert set screw (packaged with actuator) into the most accessible side. Tighten with size 10 IP Torx Plus bit to 20 - 25 lb-in (2.3 to 2.8 N-m).
2. Apply power to the actuator and check the system operation for heating or cooling output in response to the control signal.

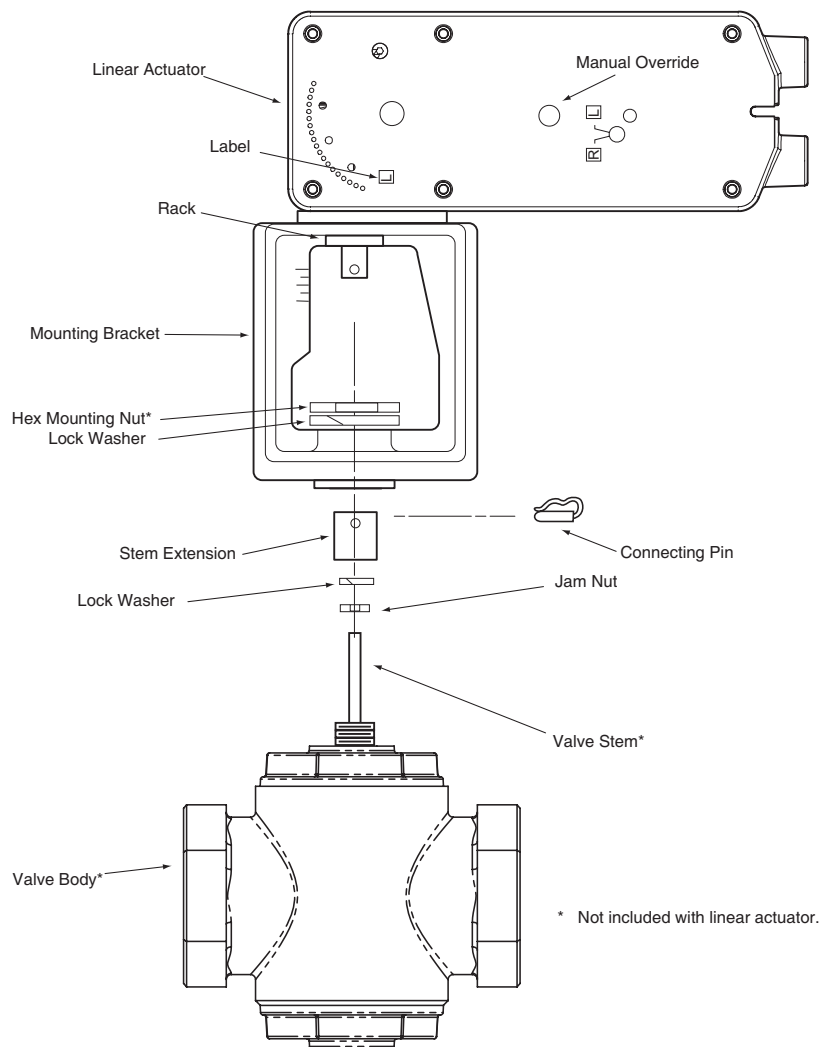

Figure 12 Mx61-720x Series Actuator Exploded View.

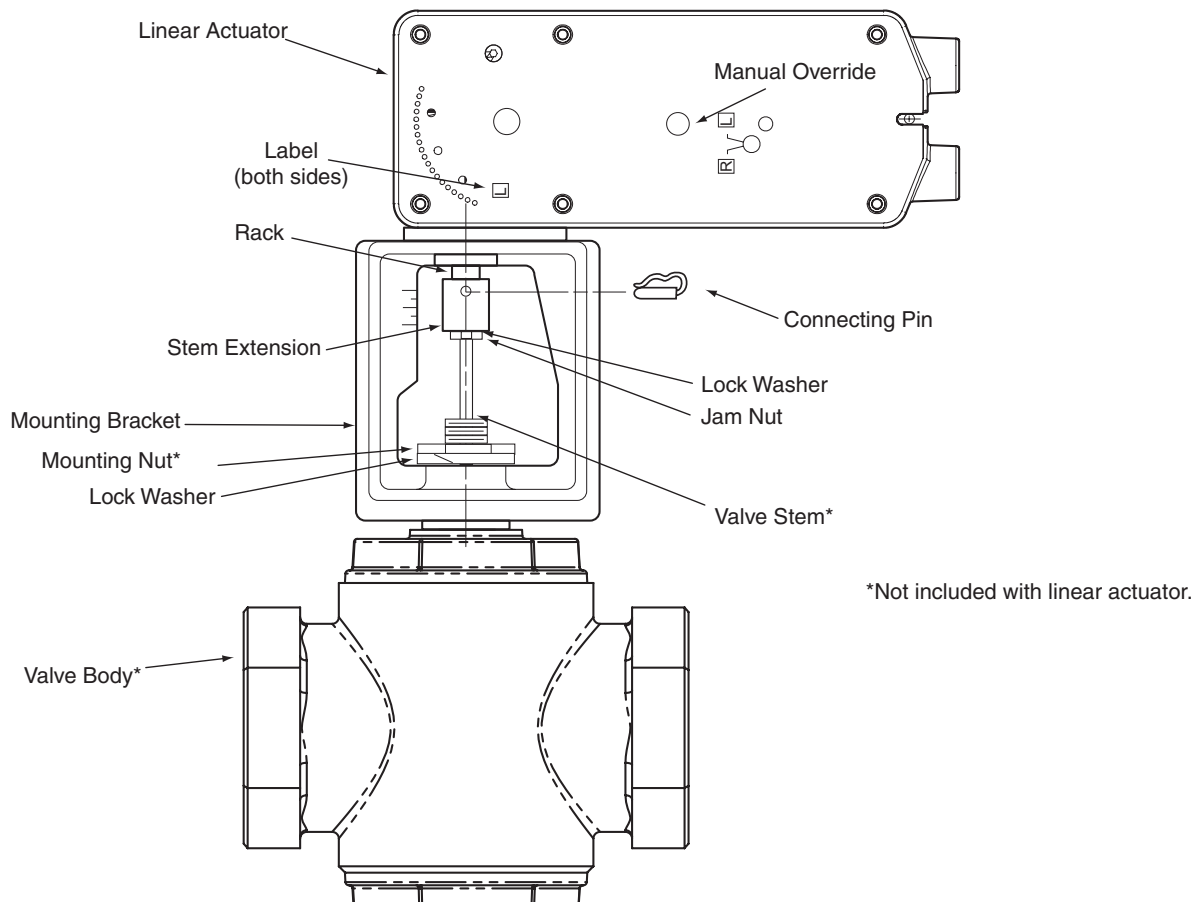

Figure 13 Typical Assembly and Installation.

Mx61-720x Series Actuator to 2½" to 4" VB-9xxx and 2½" to 5" VB-8xxx Series Valve Bodies, Stem-Up Closed 2-Way and 3-Way

1. Install the actuator onto the valve. Set up the assembly according to the numbered steps in Figure 13.
 - a. Locate the jam nut that came packaged with the actuator.
 - b. Screw the jam nut onto the valve stem all the way as far as it will go (you may need to use a 3/4" open-end wrench). At least ½" of the valve stem threads should extend above the nut. Place the lock washer over the valve stem.
 - c. Thread the stem extension onto the valve stem, making contact with the lock washer and jam nut.
 - d. Ensure 15° or 1½ turns of manual override actuator preload. See Figure 18.
 - e. Orient the actuator mounting bracket on the valve, place lock washer over valve stem and tighten the mounting nut securely against the bracket using spanner wrench. Raise the valve stem to the full up position.
 - f. Rotate stem extension until the through hole lines up with the through hole of actuator rack. Insert connecting pin to secure stem extension and tighten jam nut against stem extension using 3/4" open end wrench.
 - g. Affix open/closed label to the indicator in the appropriate position.
2. Apply power to the actuator and check the system operation for heating or cooling output in response to the control signal.

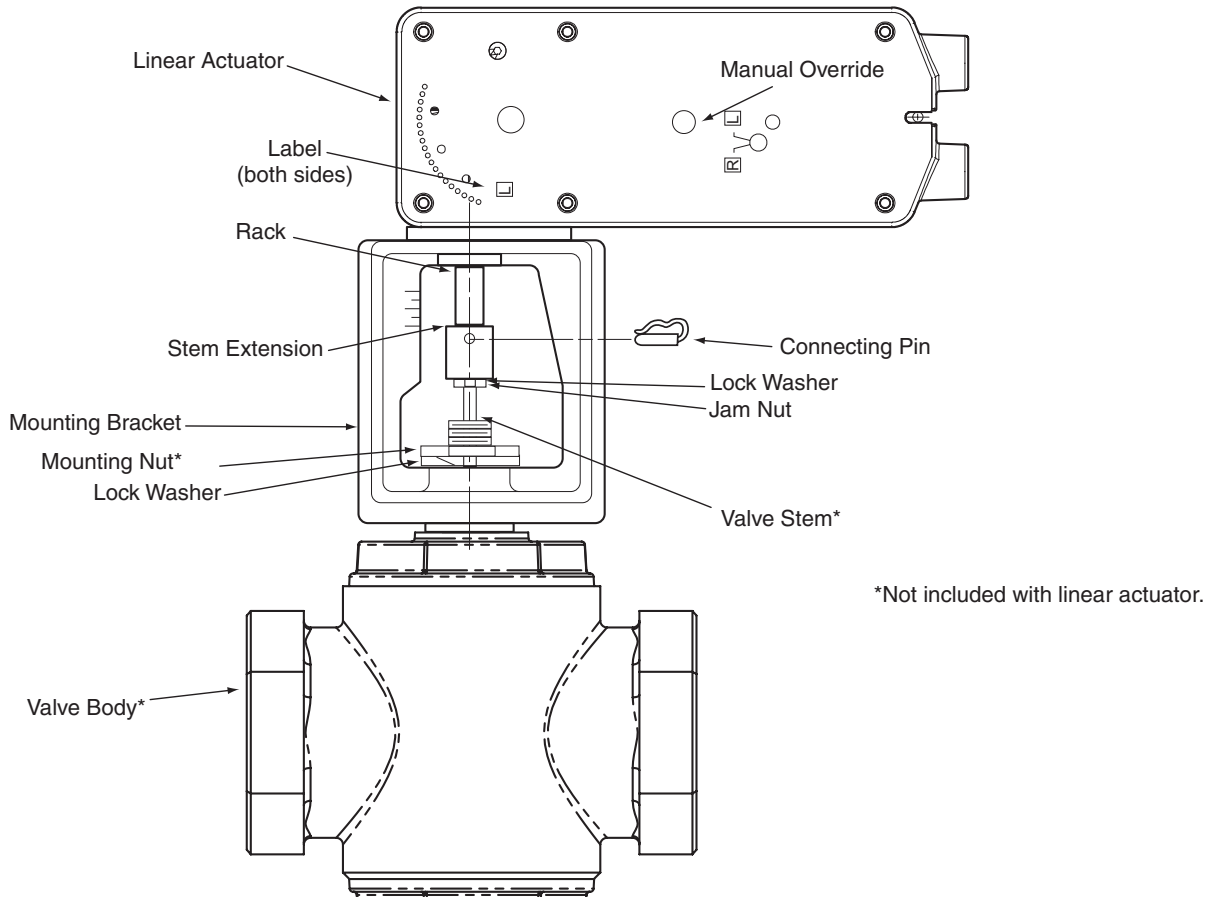

Figure 14 Typical Assembly and Installation.

Mx61-720x Series Actuator to 2½" to 4" VB-9xxx Series and 2-½" to 5" VB-8xxx Valve Bodies, 2-Way Stem-Up Open

1. Install the actuator onto the valve. Set up the assembly according to the numbered steps in Figure 14.
 - a. Locate the jam nut that came packaged with the actuator.
 - b. Screw the jam nut onto the valve stem all the way as far as it will go (you may need to use a 3/4" open-end wrench). At least ½" of the valve stem threads should extend above the nut. Place the lock washer over the valve stem.
 - c. Thread the stem extension onto the valve stem, making contact with the lock washer and jam nut.
 - d. Orient the actuator mounting bracket on the valve. Place lock washer over valve stem and tighten the mounting nut securely against the bracket using spanner wrench. Ensure the valve stem is completely pushed down.
 - e. Insert the hex wrench into manual override and crank to extend the actuator rack to its fully extended position, back off 1½ turn, and lock (see Figure 18). Remove hex wrench to prevent accidental spring return of the actuator.
 - f. Rotate stem extension until the through hole lines up with the through hole of actuator rack. Insert connecting pin to secure the assembly. Tighten jam nut against stem extension using 3/4" open end wrench.
 - g. Affix open/closed label to the indicator in the appropriate position.
2. Apply power to the actuator and check the system operation for heating or cooling output in response to the control signal.

Valve Mounting

The valve should be mounted in a weather-protected area, in a location that is within the ambient temperature limits of the actuator. The installation of the actuator assembly should provide clearance on all sides to allow for any maintenance that may be needed (see Figure 15 and Figure 17). Install the valve according to the instructions in the appropriate valve body General Instructions sheet (see Applicable Literature).

Caution: Linear actuators are designed to effectively support its own weight. No load or weight should be resting on the actuator as long term damage may occur to the actuator, the mounting connection, or the valve.

- Do not insulate the actuator/linkage. Doing so will result in excess heat buildup within the actuator.
- On non-steam applications the globe valve assembly must be mounted so that the actuator is at least 5° above the horizontal (Figure 15) to ensure that any condensate that forms will not travel into the mounting bracket or actuator.
- On steam applications, the globe valve assembly must be mounted at 45° from vertical. (Figure 16).

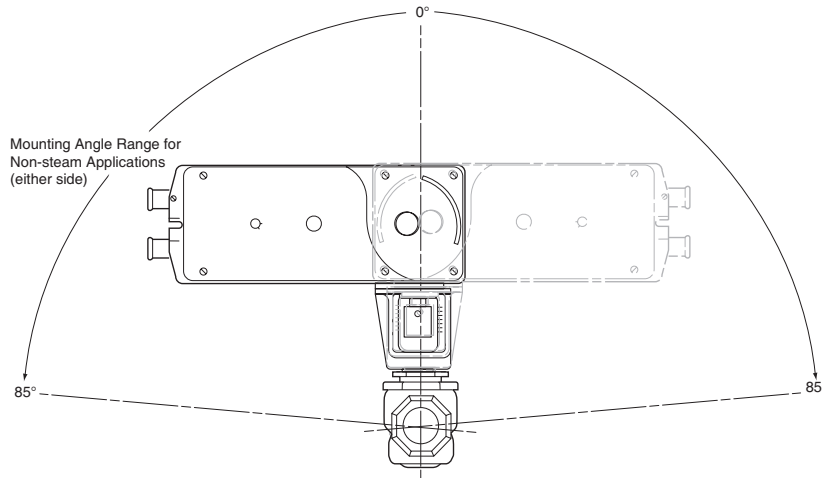

Figure 15 Typical Mounting Position.

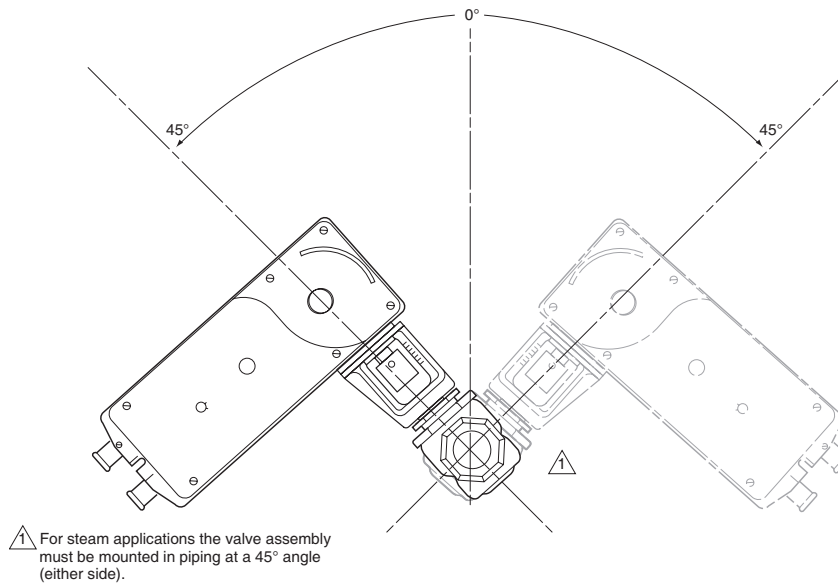

Figure 16 Typical Mounting Position for Steam Applications

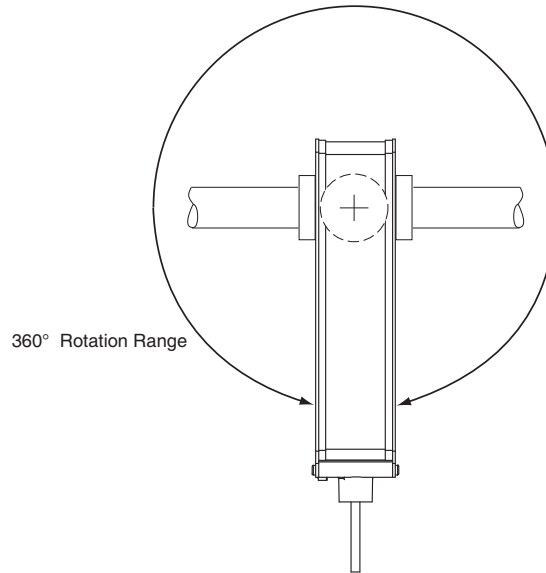
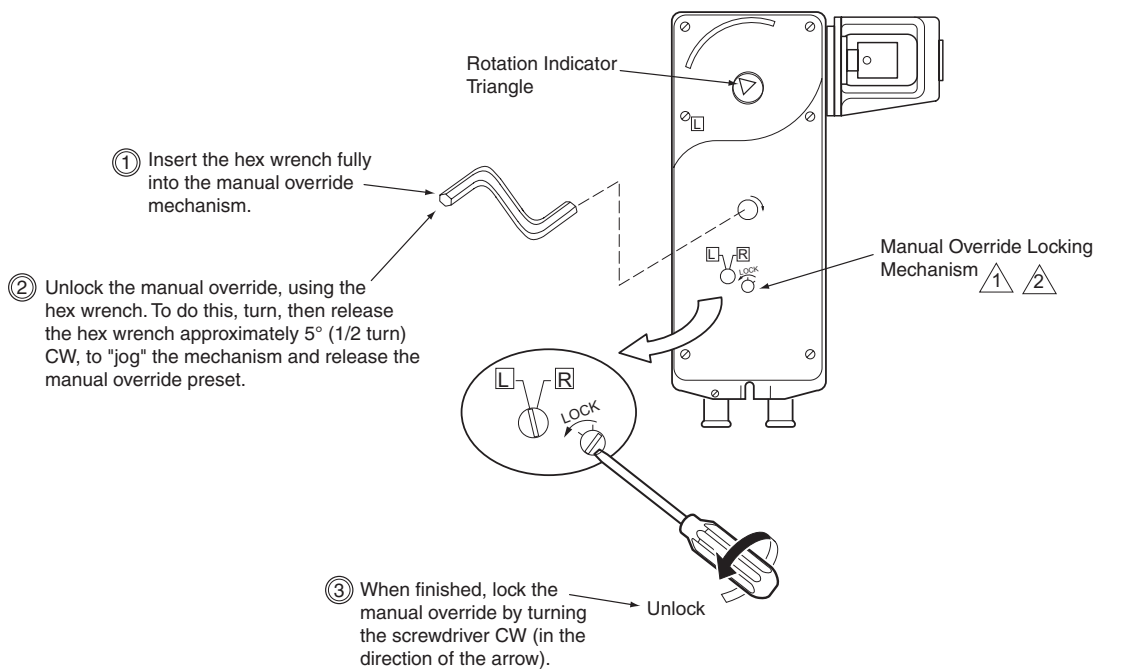

Figure 17 Typical Mounting Position for Steam Applications



1 When necessary, the manual override mechanism may be used to reposition the actuator at any point between -5° and 85° . This mechanism is accessible on both sides of the actuator and can be used to ensure tight close-offs for valves.

2 When using the manual override mechanism:

- Fully engage the hex wrench in the manual override before cranking.
- When operating the manual override, ensure proper release by backing off 5° from the full extended mechanical stop.

Figure 18. Manual Override

Caution:

- Only use manual override when the actuator drive motor is not powered.
- Engaging the manual override when the actuator is powered will cause damage to the gears.
- Using power tools to adjust the override will cause damage to the gears.
- Avoid manually repositioning the actuator beyond its adjustable travel limit setting.

Wiring Requirements

Control Leads

See Table 3 for power wiring data. Refer to Figure 1 through Figure 7 for typical wiring.

Table 3. Power Wiring.

Actuator Voltage	Part Number	Maximum Wire Run in ft. (m)					
		12 AWG	14 AWG	16 AWG	18 AWG	20 AWG	22 AWG
24 Vac 22...30 Vdc	MAx1-7203	-	330 (101)	200 (61)	130 (40)	-	-
	MFx1-7203	500 (152)	300 (91)	200 (61)	130 (40)	80 (24)	50 (15)
	MSx1-7203	600 (183)	380 (116)	240 (73)	150 (46)	90 (27)	60 (18)

After the entire system has been installed and the actuator has been powered up, the following check can be made for proper system operation. Check for correct operation of the valve while actuator is being stroked.

1. Apply power to the actuator. Actuator and valve should be driven to their powered position as determined by the control signal.
2. Remove power from the actuator. Actuator and valve should return to the spring return position.

Note: Check that the transformer(s) are sized properly. (24 Vac)

- If a common transformer is used with multiple actuators, make sure that polarity is observed on the secondary. This means connecting all black wires to one leg of the transformer and all red wires to the other leg of the transformer.
- If multiple transformers are used with one control signal, make sure all black wires are tied together and tied to control signal negative (-).
- If the controller uses a full-wave power supply and does not provide isolated outputs, a separate transformer is required.

Theory of Operation

The MA, MF and MS series actuators are directly mounted onto the valve without the use of separate linkage. They are equipped with true mechanical spring return operation for reliable, positive actuator operation in the unpowered condition.

Linear series actuators use a brushless DC motor which is controlled by a microprocessor. The microprocessor supplies the intelligence to provide a constant motion rate and to know the actuator's exact normal position and to match actuator mechanical stroke to the control input signal range on proportional (MS) models. The microprocessor monitors and controls the brushless DC motor's rotation and provides a digital rotation sensing function to prevent damage to the actuator in a stall condition. The actuator may be stalled anywhere in its normal rotation without the need of mechanical switches.

When power is applied to two-position (MA) models, the actuator moves to its full stroke position, at the same time tensing the spring return mechanism. When power is removed, the spring returns the actuator to its normal position.

When power is applied to floating (MF) and proportional (MS) models, the actuator first moves to its zero position, then moves to the position dictated by the control input signal. For proportional (MS) models, when the actuator encounters a stall condition (end of valve stroke), it recalibrates itself if necessary so that its mechanical stroke matches the control signal input span. The feedback signal range is also matched to the mechanical stroke. If power is lost, the actuator spring returns to its normal position.

Maintenance

Regular maintenance of the total system is recommended to assure sustained optimum performance. The Linear series actuators are maintenance free.

Field Repair

Actuator: None. For replacement contact your Schneider Electric Representative and specify the desired model number from Table 1.

Linkage parts: All are supplied with the actuator. Stem extension, jam nut, washer, and connecting pin may be purchased separately if lost. See Accessories.

Dimensional Data

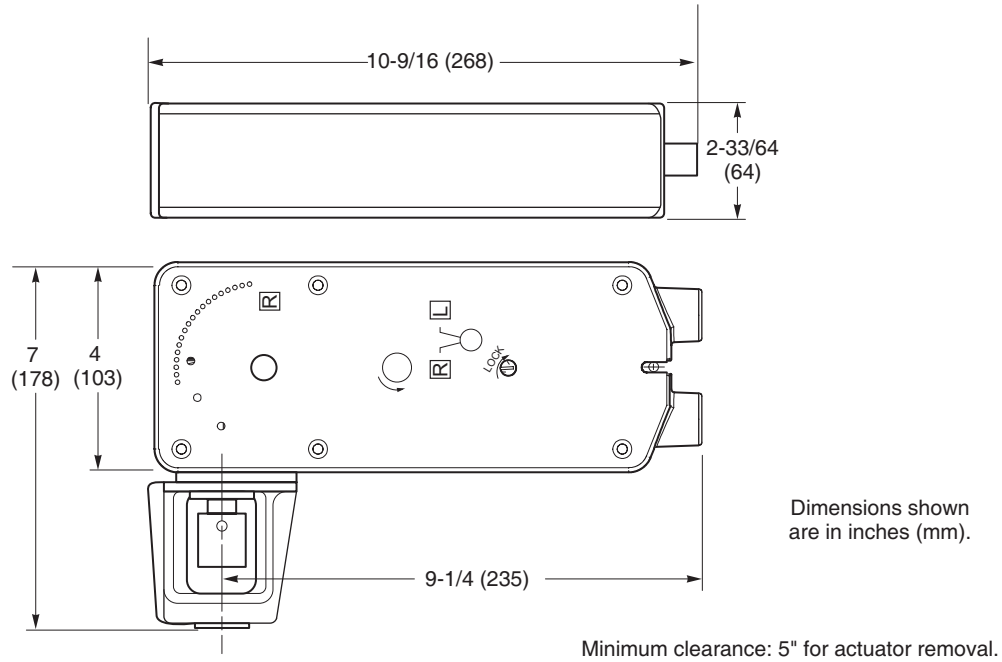

Figure 19 Mx51-720x Spring Return Valve Actuator Dimensions.

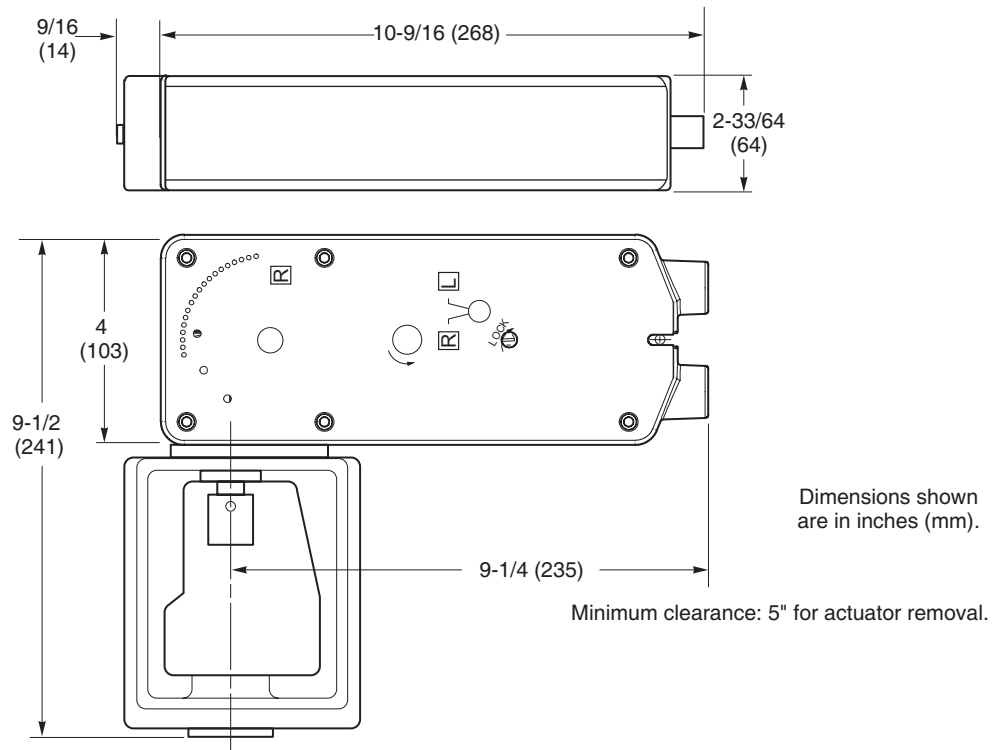

Figure 20 Mx61-720x Spring Return Valve Actuator Dimensions.

Commercial Reference	Range Brand		Product Description			
MA51-72XX MS51-72XX MF51-72XX	SMARTX LINEAR ACTUATORS		MA5 2-POSITION 220-LBF SPRING-RETURN MS5 PROPORTIONAL 220-LBF SPRING-RETURN MF5 FLOATING 220-LBF SPRING-RETURN			
有害物质 - Hazardous Substances						
部件名称 Part Name	铅 (Pb)	汞 (Hg)	镉 (Cd)	六价铬 (Cr (VI))	多溴联苯 (PBB)	多溴二苯醚(PBDE)
属部件 Metal Parts	X	O	O	O	O	O
塑料部件 Plastic Parts	O	O	O	O	O	O
电子件 Electronic	X	O	O	O	O	O
线缆和线缆附件 Cables & cabling accessories	O	O	O	O	O	O
<p>本表格依据 SJ/T11364 的规定编制。</p> <p>O: 表示该有害物质在该部件所有均质材料中的含量均在 GB/T 26572 规定的限量要求以下。</p> <p>X: 表示该有害物质至少在该部件的某一均质材料中的含量超出 GB/T 26572 规定的限量要求。 (企业可在此处, 根据实际情况对上表中打“X”的技术原因进行进一步说明。)</p> <p>This table is made according to SJ/T 11364.</p> <p>O: indicates that the concentration of hazardous substance in all of the homogeneous materials for this part is below the limit as stipulated in GB/T 26572.</p> <p>X: indicates that concentration of hazardous substance in at least one of the homogeneous materials used for this part is above the limit as stipulated in GB/T 26572</p>						



