

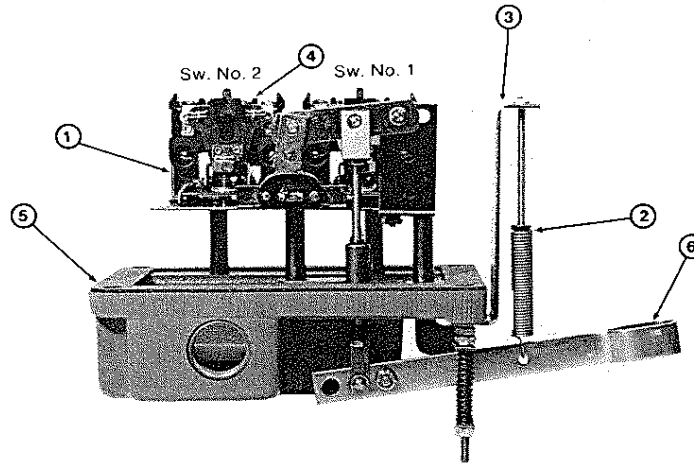

Class 9038 Types AR, AW
MECHANICAL ALTERNATOR



REPLACEMENT PARTS

Item Number	Description	Nbr. Req'd	Part Number
1	Switch mechanism (AW, AR, including Form R)	1	1551-B19-G3
2	Comp. spring assy.	1	1551-G19
3	Bracket for comp. spring	1	1551-L24-X1
4	Set of movable and stationary contacts	2	9998 PC 242
	(Includes all attaching parts)		
5	Gasket (AW)	1	1551-D20-X1
6	Oper. lever assy.	1	1551-D18-G1
6	Oper. lever assy. (Form R)	1	1551-D18-G2

When ordering replacement parts, always give complete Nameplate data.

NOTE: Float accessories are not included on AR, AW. AR and AW have a compensating spring as standard and use center hole floats.

INSTRUCTIONS

WARNING — To avoid shock hazard, disconnect all power before installing or servicing device.

APPLICATION — A means of mechanically alternating the operation of two pumps installed in a duplex system with a common tank. Under peak conditions, both pumping units are automatically placed in operation.

STANDARD ACTION — Contacts close on liquid rise.

REVERSE ACTION — Contacts open on liquid rise. IT IS NOT RECOMMENDED THAT A CHANGE BE MADE IN THE FIELD FROM STANDARD TO REVERSE ACTION OR VICE VERSA.

ADJUSTMENT — The alternators are pre-set at the factory for proper operation. Adjustments should not be attempted.

- COMPENSATING SPRING ADJUSTMENT** —
- (a) Mount the tubing complete with stop collars, (less float) on the arm.
 - (b) Place the lever arm in the upward position. Adjust the tension so the lever is maintained in this position.
 - (c) Place the lever arm in the downward position. Adjust the tension so the lever remains in this position.
 - (d) Check b and c.

Results — The float must be bouyant enough to trip the switch up and have weight enough to trip the switch down.

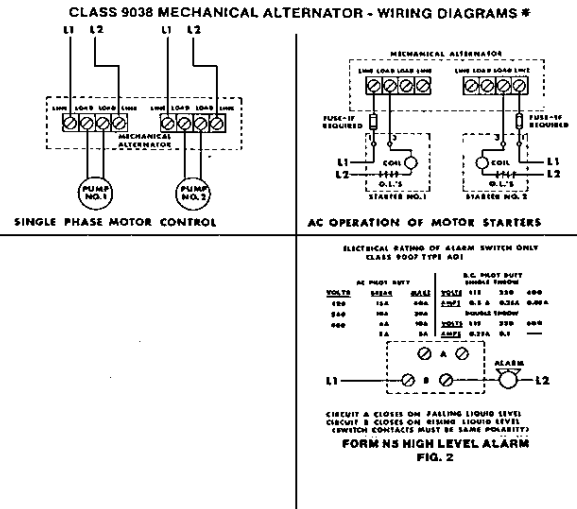

* WHERE SEPARATE POWER SUPPLIES ARE PROVIDED THE DISCONNECT MEANS FOR EACH MOTOR MUST BE GROUPED TOGETHER AND PROVIDED WITH SUITABLE WARNINGS IN ACCORDANCE WITH THE NATIONAL ELECTRICAL CODE AND ALL OTHER APPLICABLE CODES AND STANDARDS

ELECTRICAL RATINGS

Voltage	Single Phase AC	Polyphase AC	DC
115	2 H.P.	3 H.P.	½ H.P.
230	3 H.P.	5 H.P.	½ H.P.
460/575	—	1 H.P.	—
32	—	—	¼ H.P.

Contact Circuit Rating: NEMA 600A

APPROXIMATE DIMENSIONS

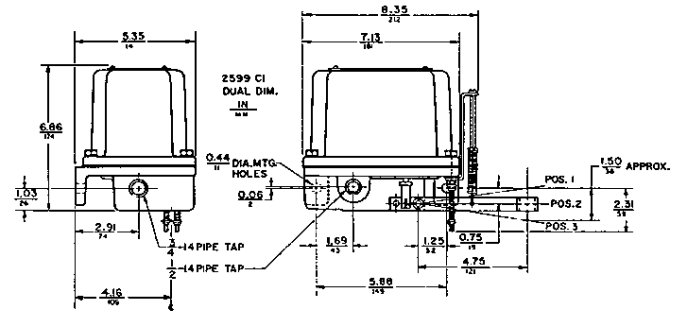

The alternating of two pumps takes place at position 2. Position 1 is reached only when one pump is unable to control the liquid level.

TABLE OF OPERATING FORCES — TYPES AR AND AW
FOR AID IN THE SELECTION OF FLOAT AND ROD IF NOT USING SQUARE D ACCESSORIES OR IF ADDITIONAL TUBING IS TO BE USED WITH CLASS 9049 A-6 ACCESSORIES.

Type	Without Comp. Spring (No. Form C)		Maximum Weight of Tubing and Stops That Can Be Supported by Compensating Spring Note: AW-1 and AR-1 have compensating spring standard	Length of Rod Which Can Be Supported with Compensating Spring at Max. Adjust		
	Force Up*	Force Down		† Brass	† Stainless Steel	† Aluminum
AR-1, AW-1 (Standard Lever)	—	—	74	16	20	41
AR-1, Form R, AW-1 Form R (Std. Lever)	—	—	85	19	23	47

† Rod length has been determined using weight of rod material furnished on Class 9049 accessories (3/8" O D tubing) Other types of rod should be weighed and compared to weight of tubing column in the table above.

* Add 2 oz. for Form N5 High Water alarm.

MANUAL TRANSFER (LEAD-LAG) SELECTOR FORM N3 — These switches have a manually engaged selector which voids alternation. When the N3 lever is lifted up and positioned to the left, the pump controlled by Switch No. 2 will lead and Switch No. 1 will lag. By lifting up on the lever and swinging it to the right, Switch No. 1 will lead and Switch No. 2 will lag. Placing the lever in its mid position returns the control to normal alternator operation.

NON-ALTERNATING MECHANISM (FORM N4) — On these alternators, the pump wired to lead (which is Switch No. 1) always comes on first with the second pump operating only under peak conditions or when first pump fails.

HIGH WATER ALARM (Form N5) — On these switches an additional snap switch mechanism is tripped initiating a high water alarm circuit if for any reason both pumps are unable to control the rising of liquid in the tank. See Fig. 2.

MOUNTING — The alternator is mounted in a horizontal position by means of the two holes located in the base casting.

MOTOR PROTECTION — A control of this type does not afford motor protection. However, it is quite frequently used as a pilot to operate a starter providing this desirable feature. Square D Company manufactures a complete line of motor protective devices, information on which will be sent upon request.