

# SQUARE D®

## CLASS 9999, TYPES R-41 AND R-42, SERIES A ELECTRICAL INTERLOCKS

Type R-41 is a single pole double throw electrical interlock.  
Type R-42 is a double pole double throw electrical interlock.

Instruction Sheet  
30072-303-54C  
DECEMBER, 1986

**DANGER - HAZARD OF ELECTRICAL SHOCK OR BURN. TURN OFF POWER SUPPLYING THIS EQUIPMENT BEFORE INSTALLING OR SERVICING.**

### INTERLOCK ARM ASSEMBLY:

1. Place disconnect switch operating handle in the **OFF** position.
2. Position the electrical interlock arm, Item 4, on the lower forward ear "D" as shown in Fig. 1.
3. For right hand mounting, line up the left tapped hole on the interlock arm with the clearance hole on formed ear "D". See Fig. 1. For left hand mounting, line up the right most tapped hole on the interlock arm with the clearance hole. The interlock arm, Item 4, should rest against the inside of formed ear "E". See Fig. 2.
4. Secure the electrical interlock arm, Item 4, to the operating mechanism operator cam as shown in Fig. 1 using lockwasher, Item 5, and hex socket cap screw, Item 6.

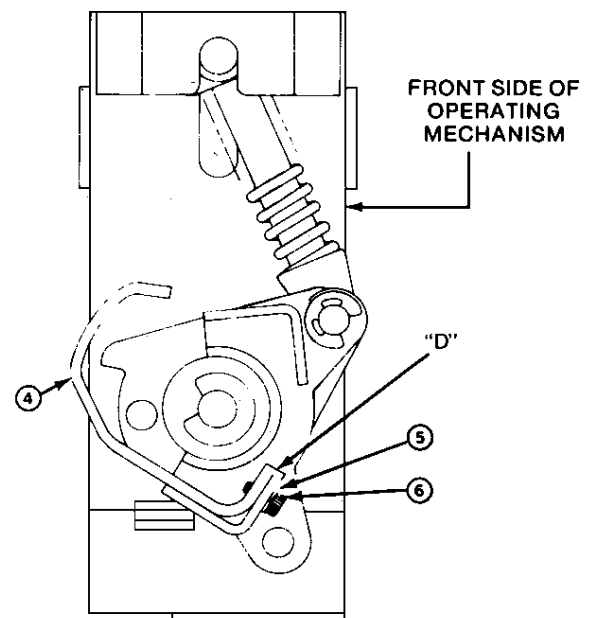

**Figure 1**  
(Shown in OFF position)

### CLASS 9999 TYPE R-41 (ONE POLE)\*

Volts	AC Pilot Duty Amperes▲		Volts	DC Pilot Duty Amperes ‡	
	Make	Break		Single Throw	Double Throw
120	40	15	125	2.00	0.50
240	20	10	250	0.50	0.20
480	10	6	600	0.10	0.02
600	8	5			

### CLASS 9999 TYPE R-42 (TWO POLE)\*\*

Volts	AC Pilot Duty Amperes▲		Volts	DC Pilot Duty Amperes ‡	
	Make	Break		Single Throw	Double Throw
120	30.0	3.00	125	1.0	0.2
240	15.0	1.50	250	0.3	0.1
480	7.5	0.75	600	0.1	—
600	6.0	0.60			

\*\*AC continuous ampere rating is 10 amperes based on a 75% power factor.

\*AC continuous ampere rating is 15 amperes based on a 75% power factor.

▲AC pilot duty rating is based on 35% power factor.

‡DC pilot duty rating is based on inductive loads such as coils and solenoids.

**SQUARE D®**

### INSTALLATION OF INTERLOCK:

1. For right hand operating disconnect switch;
  - A. Thread locknut "C", all the way onto the threaded plunger housing.
  - B. If disconnect switch is fusible type, remove fuse base assembly.
  - C. Back out screw assembly "A" 5/8 inch.
  - D. With disconnect switch in the **ON** position, screw interlock assembly, Item 1 or 2, into 15/32-32 tapped hole on the right hand side of disconnect switch saddle, until snap switch has operated.
  - E. Rotate interlock assembly, Item 1 or 2, one more full turn plus whatever fraction of a turn it takes to position the surface marked "This Surface Must Face Enclosure Opening," facing the enclosure opening.
  - F. Turn screw "A" until it is engaged into the tapped hole "B" provided on the disconnect switch assembly until its head is tight against the electrical interlock snap switch.
  - G. If disconnect switch fuse base was removed in Step 1B above, replace it at this time.
  - H. Close liner after wiring interlock switch.
  
2. For left hand operating disconnect switch:
  - A. Follow same steps 1A, 1B, 1C, 1D and 1E.
  - B. Turn lock nut "C" and secure it tightly against the disconnect switch assembly.
  - C. Turn screw "A" in until the head of the screw is tight against the interlock snap switch.
  - D. Close liner after wiring switch.

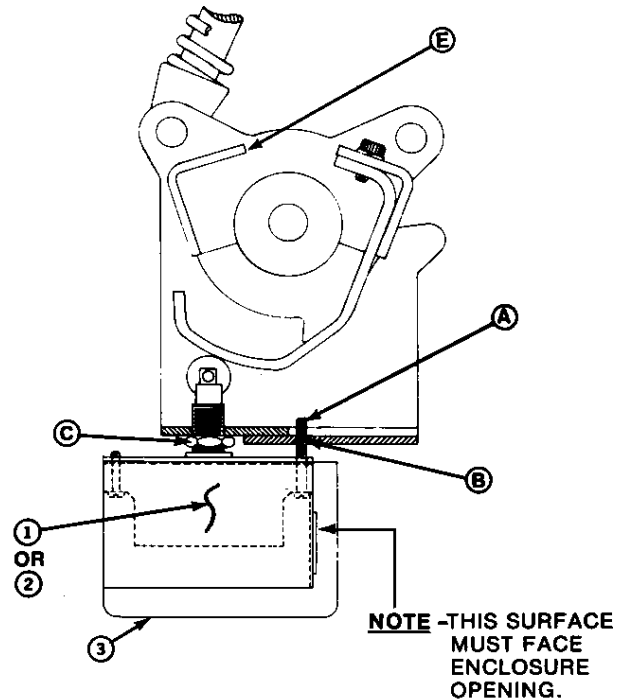

**Figure 2**  
(Shown in **ON** position)

### REPLACEMENT PARTS LIST

Item	Description	Part No.	Qty.
1	S.P.D.T. Snap Switch (For Type R41 Only)	Cl. 9007 A02	1
2	D.P.D.T. Snap Switch (For Type R42 Only)	Cl. 9007 C03	1
3	Liner	31004-304-01	1
4	Interlock Arm	31055-412-01	1
5	#8 Lockwasher	23701-00140	1
6	#8-32 x 1/2 Hex Socket Hd. Cap Screw	21601-14160	1