



CLASS 9999 TYPE LXS SELECTOR SWITCH KIT

For Class 8903 Type LX Lighting Contactors
In NEMA Type 1 Removable Cover Enclosures

FOR USE WITH THE CLASS 9999, TYPE BLX MOUNTING BRACKET

1. Loosen device mounting screws and remove device from enclosure.
2. Attach the Class 9999, Type BLX mounting bracket to the enclosure with the two thread-forming #8-32 screws provided with the bracket kit. Refer to Figure 1 for proper orientation of bracket.
3. Loosen the two selector switch mounting screws and attach switch such that flange is flush with top of bracket. See Figure 1.
4. Replace the device and tighten mounting screws.
5. Using one of the wires included in this kit, wire from terminal 2A on the selector switch to terminal 14 on the latch coil.
6. Using the other wire included in this kit, wire from terminal 1A on the selector switch to terminal 15 on the unlatch coil.
7. Connect control voltage source to terminal 3A on the selector switch and terminal 18 on the coil clearing switch.
8. Remove large rectangular knockout from enclosure cover to complete installation.

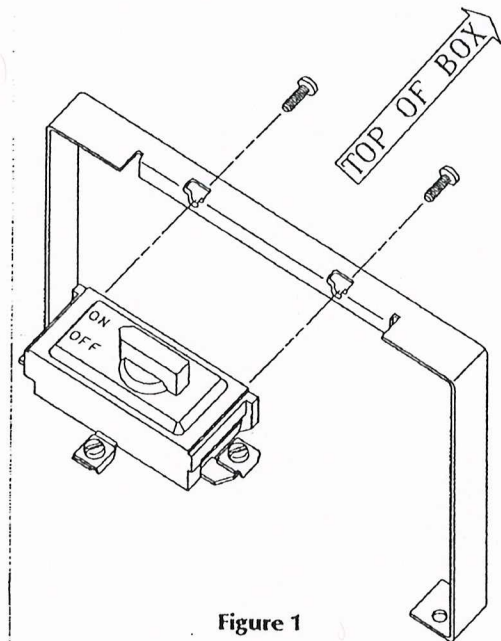

Figure 1

