

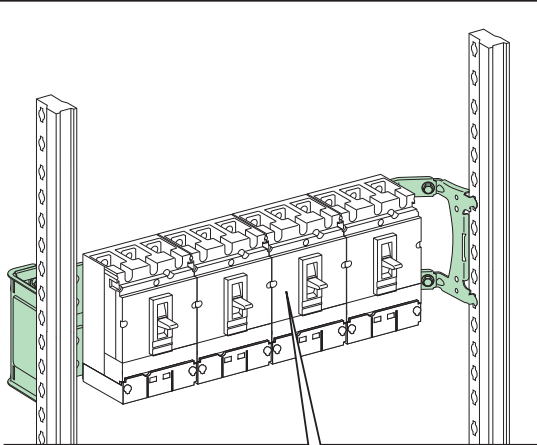

en fr es de it pt zh ru

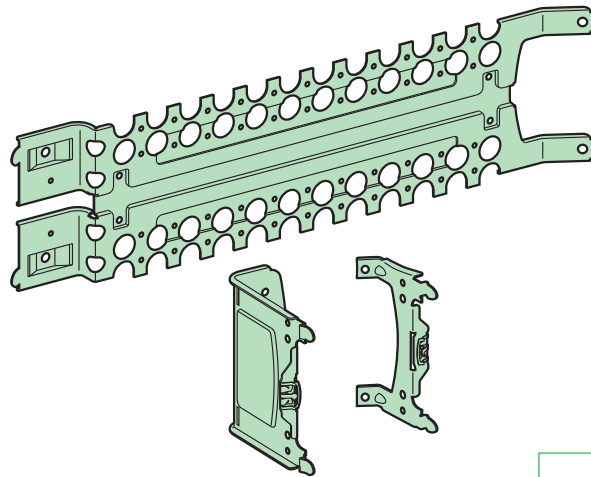

Compact NSX 100/160/250	3P/4P
Easypact CVS 100/160/250	3P/4P
Compact NSX Vigi 100/160/250 (ELCB)	3P/4P
Easypact Vigi CVS 100/160/250	3P/4P
Compact Vigi NSX 100/160/250	3P/4P
Compact NSX 100/160/250 + CT	3P/4P
Compact INS-INV 250	4P
PowerTag NSX 100/160/250	3P/4P
PowerTag NSX Vigi 100/160/250 (ELCB)	3P/4P
PowerTag INS-INV 250	4P



x4



<p><b>PLEASE NOTE</b> Electrical equipment should be installed, operated, serviced, and maintained only by qualified personnel. No responsibility is assumed by Schneider Electric for any consequences arising out of the use of this material.</p>	<p><b>REMARQUE IMPORTANTE</b> L'installation, l'utilisation, la réparation et la maintenance des équipements électriques doivent être assurées uniquement par du personnel qualifié. Schneider Electric décline toute responsabilité quant aux conséquences de l'utilisation de ce matériel.</p>	<p><b>TENGA EN CUENTA</b> La instalación, manejo, puesta en servicio y mantenimiento de equipos eléctricos deberán ser realizados sólo por personal cualificado. Schneider Electric no se hace responsable de ninguna de las consecuencias del uso de este material.</p>	<p><b>BITTE BEACHTEN</b> Elektrische Geräte dürfen nur von Fachpersonal installiert, betrieben, bedient und gewartet werden. Schneider Electric haftet nicht für Schäden, die durch die Verwendung dieses Materials entstehen.</p>
<p><b>NOTA</b> Manutenzione, riparazione, installazione e uso delle apparecchiature elettriche si devono affidare solo a personale qualificato. Schneider Electric non si assume alcuna responsabilità per qualsiasi conseguenza derivante dall'uso di questo materiale.</p>	<p><b>NOTA</b> A instalação, utilização e manutenção do equipamento eléctrico devem ser efectuadas exclusivamente por pessoal qualificado. A Schneider Electric não assume qualquer responsabilidade pelas consequências resultantes da utilização deste material.</p>	<p><b>请注意</b> 电气设备的安装、操作、维修和维护工作仅限于合格人员执行。Schneider Electric 不承担由于使用本资料所引起的任何后果”。</p>	<p><b>ОБРАТИТЕ ВНИМАНИЕ</b> Установка, эксплуатация, ремонт и обслуживание электрического оборудования может выполняться только квалифицированными электриками. Компания Schneider Electric не несет никакой ответственности за любые возможные последствия использования данной документации.</p>



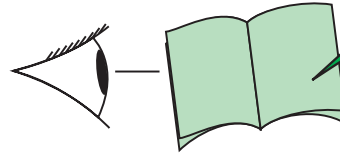
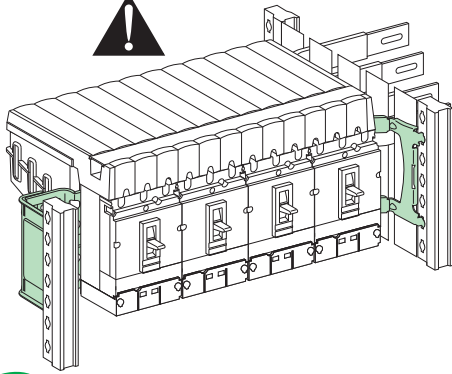

### Compact + Linergy FC

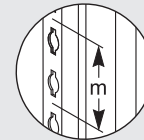
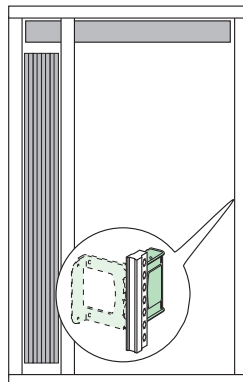
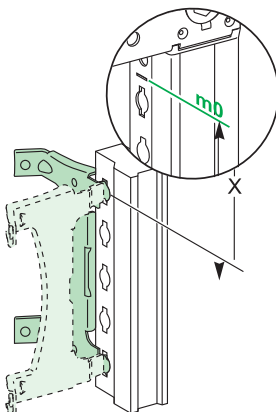
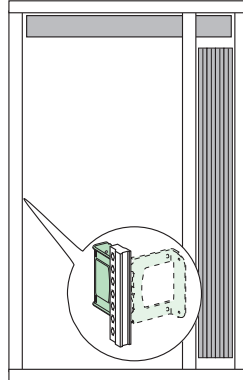
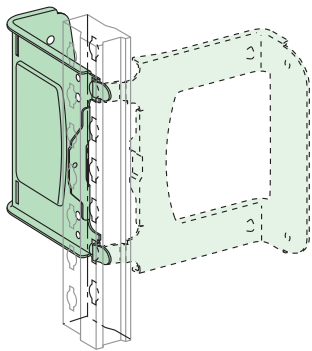
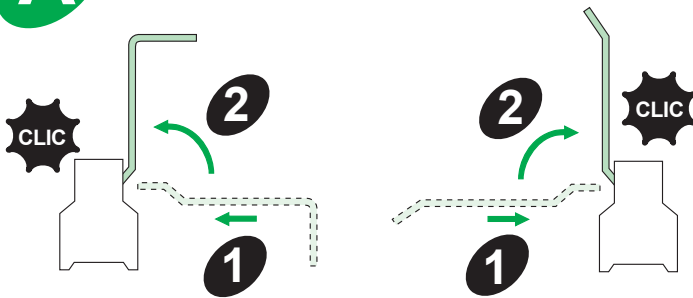

04403 04404  
04405 04406  
04407 04408



m = 50 mm

					
		X	m	X	m
NSX 100/160 CVS 100/160 NSX Vigi 100/160 (ELCB)	3P/4P 3P/4P 3P/4P	162,5	8	62,5	6
NSX 250 NSX Vigi 250 (ELCB)	3P/4P 3P/4P	162,5	9	62,5	7
Vigi CVS 100/160 Vigi NSX 100/160 NSX 100/160 + CT	3P/4P 3P/4P 3P/4P	162,5	10	62,5	8
Vigi NSX 250 NSX 250 + CT	3P/4P 3P/4P	162,5	11	62,5	9
INS-INV 250	4P	212,5	9	112,5	7
PowerTag NSX 100/160 PowerTag NSX Vigi 100/160 (ELCB)	3P/4P 3P/4P	162,5	9	62,5	7
PowerTag NSX 250 PowerTag NSX Vigi 250 (ELCB)	3P/4P 3P/4P	162,5	10	62,5	8
PowerTag INS-INV 250	4P	212,5	10	112,5	8

**B**

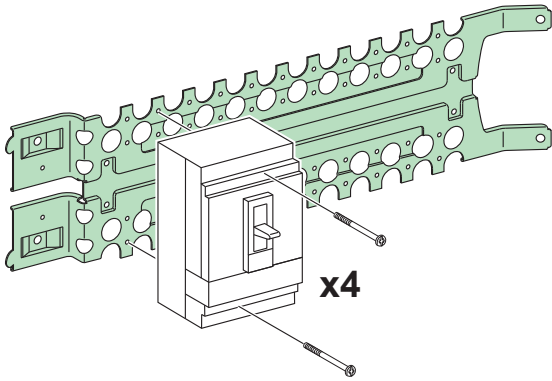

NSX 100/160/250	3P
CVS 100/160/250	3P
NSX Vigi 100/160/250 (ELCB)	3P
Vigi CVS 100/160/250	3P
Vigi NSX 100/160/250	3P
NSX 100/160/250 + CT	3P
PowerTag NSX 100/160/250	3P
PowerTag NSX Vigi 100/160/250 (ELCB)	3P

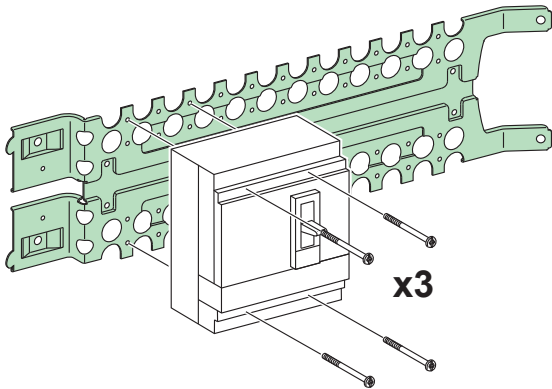
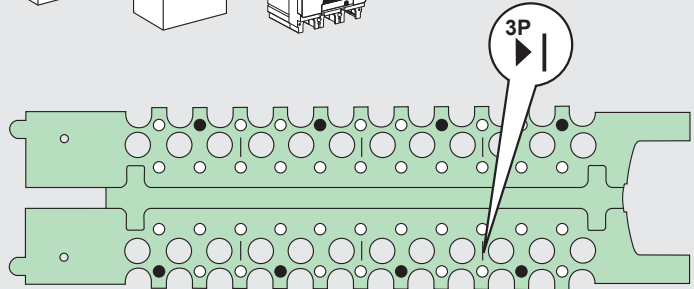
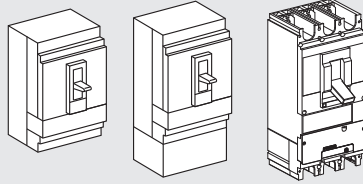

NSX 100/160/250	4P
CVS 100/160/250	4P
NSX Vigi 100/160/250 (ELCB)	4P
Vigi CVS 100/160/250	4P
Vigi NSX 100/160/250	4P
NSX 100/160/250 + CT	4P
PowerTag NSX 100/160/250	4P
PowerTag NSX Vigi 100/160/250 (ELCB)	4P

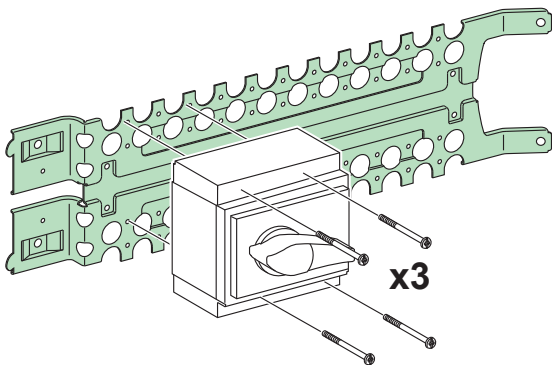
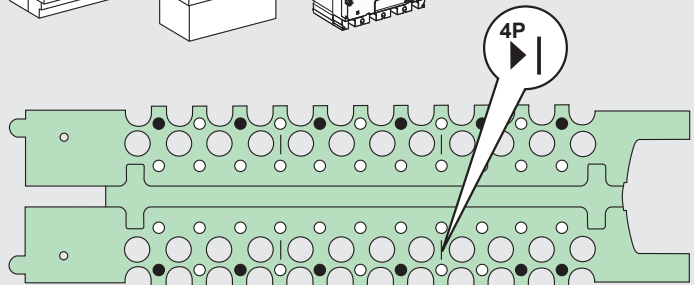
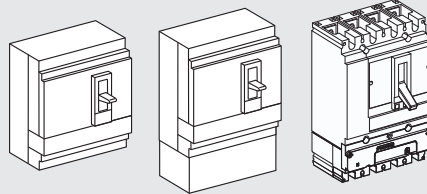

INS-INV 250	4P
PowerTag INS-INV 250	4P

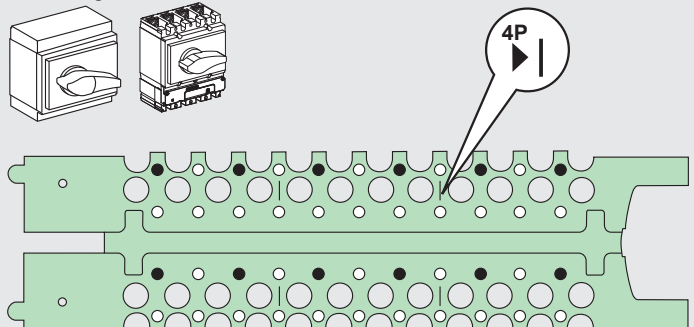
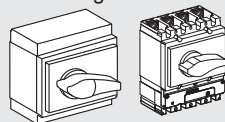

C

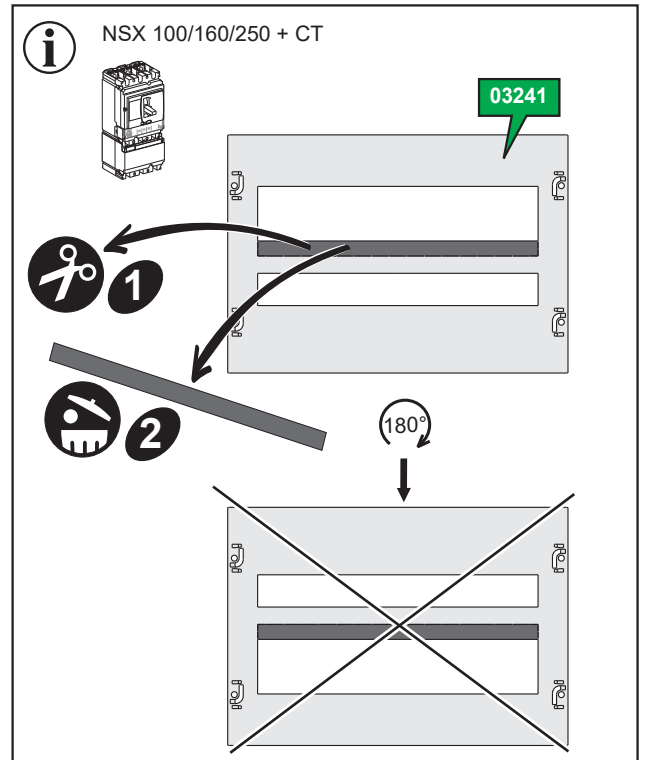
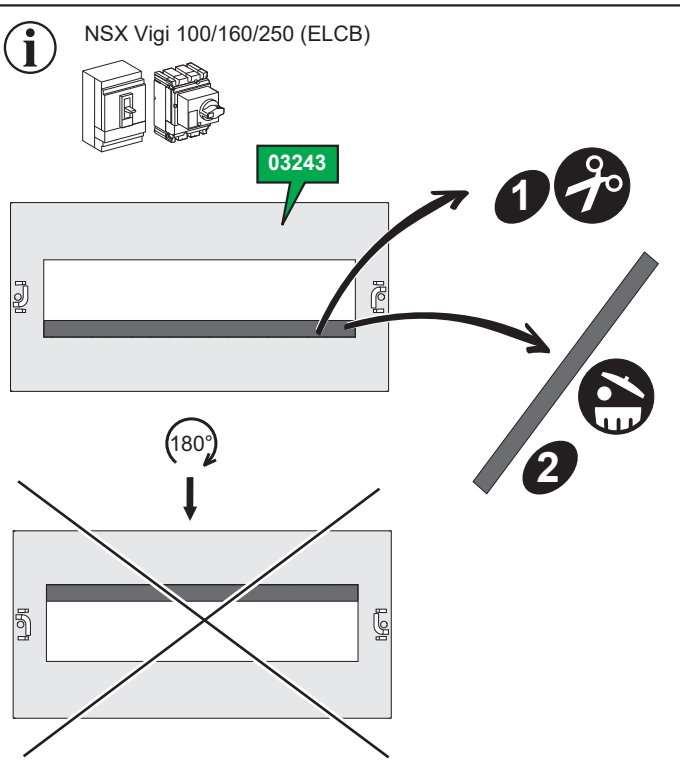
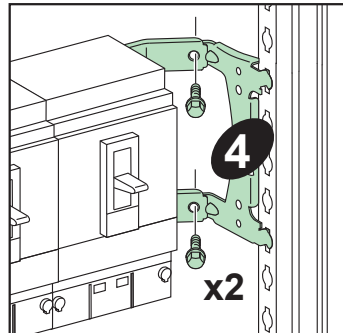
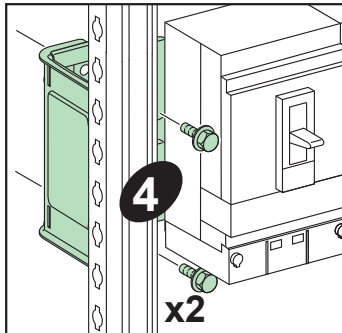
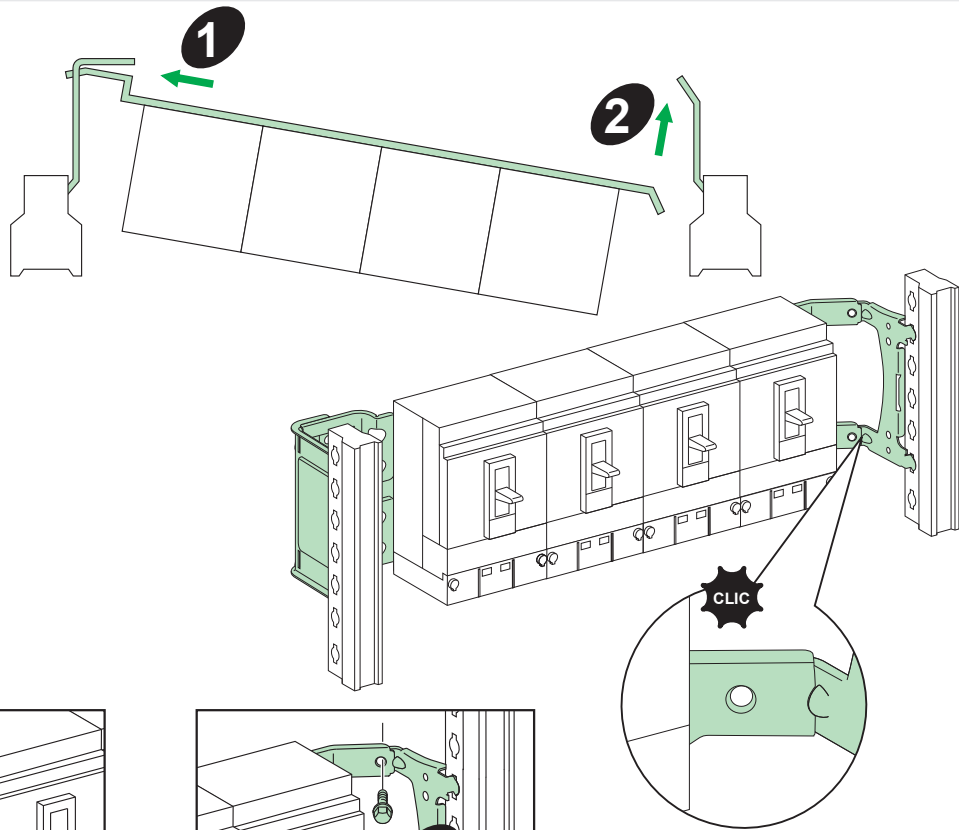

**Schneider Electric Industries SAS**  
 35, rue Joseph Monier  
 92506 Rueil Malmaison  
 France

<http://www.schneider-electric.com>

En raison de l'évolution des normes et du matériel, les caractéristiques indiquées par le texte et les images de ce document ne nous engageant qu'après confirmation par nos services.

*As standards, specifications and designs change from time to time, please ask for confirmation of the information given in this publication.*

Publication : Schneider Electric  
 Réalisation : Schneider Electric  
 Impression :  
 Format de pliage : 210 x 148.5 mm



Ce document a été imprimé sur du papier écologique.  
 This document has been printed on ecological paper.