

# Capítulo 6 Accesorios de montaje y de cableado

## Indice

<b>Referencias</b>	Montantes para la fijación de las placas y los perfiles	Págs. 6/2 y 6/3
	Placas perforadas Telequick	Págs. 6/4 y 6/5
	Perfiles para la fijación de los aparatos	Pág. 6/6
	Tornillos para la fijación de los aparatos	Pág. 6/7
	Canaletas de cableado	Pág. 6/8
	Auxiliares de cableado y montaje	Págs. 6/9 y 6/10
<b>Dimensiones</b>	Montantes y perfiles	Pág. 6/11
	Placas perforadas	Págs. 6/12 y 6/13
	Auxiliares de cableado	Págs. 6/14 y 6/15

# Accesorios de montaje y de cableado

Montantes con muescas para la fijación de las placas y los perfiles

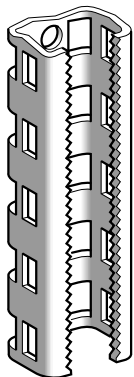

AM3-EC

## Montantes perforados con muescas

Utilización	Material y tratamiento de superficie	Altura mm	Venta por c. indiv.	Referencia unitaria	Peso kg
Ajuste del entreeje entre filas de aparatos: – con paso de 2,5 mm (muescas) – con paso de 25 mm	Chapa acero 20/10 <sup>e</sup>	1075	2	AM3-EC105	1,800
	zincada	1475	2	AM3-EC145	2,500
	zincada	1675	2	AM3-EC165	2,700
	cromatada	1875	2	AM3-EC185	3,000

### Tuercas 1/4 vuelta deslizantes, con muescas (5)

Tipo	Venta por cant. indiv.	Referencia unitaria	Peso kg
M6	10	AF1-CD6	0,053
M8	10	AF1-CD8	0,053
M10	10	AF1-CD10	0,053

### Tornillos correspondientes (5)

Tipo	Venta por c. indiv.	Referencia unitaria	Peso kg
M6 × 12 (1)	100	AF1-VA612	0,005
M6 × 18 (1)	100	AF1-VA618	0,006
M8 × 20 (2)	10	AF1-VC820	0,024
M10 × 20 (4)	10	AF1-VC10	0,033

### Tuercas clips indexadas (5)

Tipo	Venta por cant. indiv.	Referencia unitaria	Peso kg
M6	50	AA3-AA06	0,010
M8	50	AA3-AA08	0,010

### Tornillos correspondientes (5)

Tipo	Venta por c. indiv.	Referencia unitaria	Peso kg
M6 × 12 (1)	100	AF1-VA612	0,005
M6 × 18 (1)	100	AF1-VA618	0,006
M8 × 20 (2)	10	AF1-VC820	0,024

## Montantes con muescas

Utilización	Material y tratamiento de superficie	Altura mm	Venta por c. indiv.	Referencia unitaria	Peso kg
Ajuste de entreeje entre filas de aparatos por muescas con paso de 2,5 mm	Chapa acero 20/10 <sup>e</sup>	900	2	AM1-EC090	1,350
	zincada	1150	2	AM1-EC115	1,770
	cromatada	2000	2	AM1-EC200	2,980

## Tornillos y accesorios (para la fijación de las placas y los perfiles en montantes con muescas)

### Tuercas (enganche 1/4 de vuelta) (6)

Tipo	Venta por cant. indiv.	Referencia unitaria	Peso kg
M6	10	AF1-CD061	0,020
M8	10	AF1-CD081	0,020
M10	10	AF1-CD101	0,020

### Tornillos correspondientes (5)

Tipo	Venta por c. indiv.	Referencia unitaria	Peso kg
M6 × 12 (1)	100	AF1-VA612	0,005
M6 × 18 (1)	100	AF1-VA618	0,006
M8 × 20 (2)	10	AF1-VC820	0,024
M8 × 30 (3)	10	AF1-VC830	0,025
M10 × 20 (4)	10	AF1-VC10	0,033

Designación	Venta por c. indiv.	Referencia unitaria	Peso kg
Calzo de fijación de las placas (fijación Ø 8) (5)	10	AZ1-XC1	0,013
Soporte para montaje inclinado de los perfiles (fijación Ø 6) (5)	10	DZ5-MS10	0,020

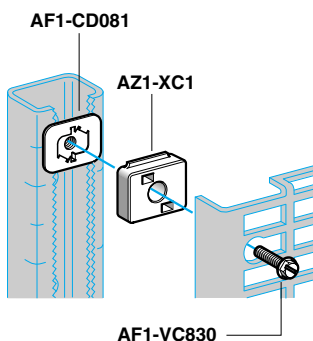

- (1) Tornillos con arandela imperdible y cabeza hexagonal con ranura.
- (2) Tornillos de cabeza hexagonal con arandela de contacto.
- (3) Tornillo con cabeza hexagonal con arandela de contacto (para fijación de la placa AM1-PA●●● sobre tuerca AF1-CD081 y calzo AZ1-XC1).
- (4) Tornillo de cabeza cilíndrica hexagonal con ranura y arandela de freno.
- (5) Acero zincado cromatado
- (6) Acero zincado cromatado, caja de tuerca inox.

# Accesorios de montaje y de cableado

Montantes perforados para la fijación de las placas y los perfiles

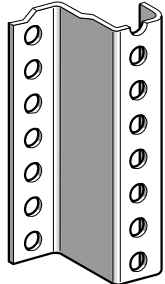

DZ6-MZ●●●

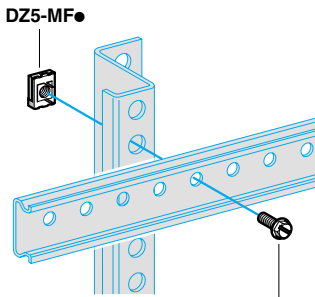

DZ5-MF●

AF1-VA●●●

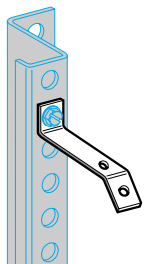

DZ5-MS10

## Montantes perforados (1)

Utilización	Material y tratamiento de superficie	Altura mm	Venta por c. indiv.	Referencia unitaria	Peso kg
Ajuste del entreje entre filas de aparatos: – con paso de 20 mm y orificios Ø 11 mm	Chapa acero 25/10 <sup>e</sup> zincada cromatada	1020	4	DZ6-MZ121	2,330
		1320	4	DZ6-MZ151	2,850
		1420	4	DZ6-MZ161	2,920
		1620	4	DZ6-MZ181	3,375
		1820	4	DZ6-MZ200	3,750
		1920	4	DZ6-MZ211	4,000

## Tornillos y accesorios (para la fijación de las placas y de los perfiles en montantes perforados)

### Tuercas de grapa (5)

Tipo	Venta por cant. indiv.	Referencia unitaria	Peso kg
M6	100	DZ5-MF6	0,007
M8	100	DZ5-MF8	0,008

### Tornillos correspondientes (5)

Tipo	Venta por c. indiv.	Referencia unitaria	Peso kg
M6 × 12 (2)	100	AF1-VA612	0,005
M6 × 18 (2)	100	AF1-VA618	0,006
M8 × 20 (3)	10	AF1-VC820	0,024

Designación	Montaje sobre perfil	Venta por c. indiv.	Referencia unitaria	Peso kg
<b>Soporte para montaje inclinado de los perfiles y borneros (fijación Ø 6)(5)</b>	DZ6-MZ AM1-EC AM3-EC	10	DZ5-MS10	0,020

- (1) Montantes para la realización de chasis destinados:  
 – a los cofres metálicos tipo ACM: ver las páginas 4/2 y 4/3,  
 – a los cofres aislantes estancos tipo AC4,  
 – a los cofres aislantes estancos tipo ACP: ver las páginas 5/5 y 5/7,  
 – a los armarios tipo AA3 y AA4.  
 (2) Tornillos con arandela imperdible y cabeza hexagonal con ranura.  
 (3) Tornillos de cabeza hexagonal con arandela de contacto.  
 (4) Tornillo de cabeza cilíndrica hexagonal con ranura y arandela de freno.  
 (5) Acero zincado cromatado.



# Accesorios de montaje y de cableado

Placas perforadas Telequick

## Placas perforadas Telequick yuxtaposicionables tipo AM3-PA (1) (2)

Entreeje de fijación		Dimensiones totales		Superficie total dm <sup>2</sup>	Referencia	Peso kg
Anchura mm	Altura mm	Anchura mm	Altura mm			
450	200	508	225	11,4	AM3-PA2045	0,950
	425	508	450	22,8	AM3-PA4045	2,600
	575	508	600	30,4	AM3-PA6045	2,400
	800	508	825	41,9	AM3-PA8045	3,400
650	200	708	225	15,9	AM3-PA2065	1,300
	425	708	450	31,8	AM3-PA4065	2,600
	575	708	600	42,4	AM3-PA6065	3,400
	800	708	825	58,4	AM3-PA8065	4,700
850	200	908	225	20,4	AM3-PA2085	1,600
	425	908	450	40,8	AM3-PA4085	3,300
	575	908	600	54,4	AM3-PA6085	4,400
	800	908	825	74,9	AM3-PA8085	6,000
1050	200	1.108	225	24,9	AM3-PA20105	2,500
	425	1.108	450	49,9	AM3-PA40105	4,000
	575	1.108	600	66,5	AM3-PA60105	5,500
	800	1.108	825	91,5	AM3-PA80105	7,100

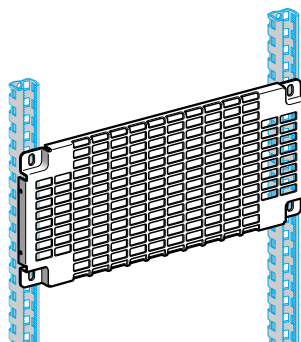

AM3-PA●●●●●

## Placas perforadas Telequick (1) (2)

### Para equipos de dimensiones reducidas

Entreeje de fijación		Dimensiones totales		Superficie total dm <sup>2</sup>	Referencia	Peso kg
Anchura mm	Altura mm	Anchura mm	Altura mm			
225	125	255	154	3,92	AM3-PA32	0,340
	175	253	228	5,76	AM3-PA325	0,400
	525	255	551	14	AM3-PA36	1,200
	725	255	751	19,1	AM3-PA38	1,500
325	175	349	228	7,95	AM3-PA425	0,520
	225	349	251	8,75	AM3-PA43	0,730
	325	345	351	12,1	AM3-PA44	0,990
425	225	454	251	11,3	AM3-PA53	0,930
	325	450	351	15,7	AM3-PA54	1,300
525	325	555	351	19,4	AM3-PA64	1,550
	425	555	451	25	AM3-PA65	1,950
	525	555	551	30,5	AM3-PA66	2,400
625	425	645	451	29	AM3-PA75	2,300
	525	645	551	35,5	AM3-PA76	2,750
725	525	750	551	41,3	AM3-PA86	3,150
	725	750	751	56,3	AM3-PA88	4,000
825	625	855	651	55,6	AM3-PA97	3,900
925	725	945	751	70,9	AM3-PA108	5,000
1.125	725	1.145	751	85,9	AM3-PA128	6,250

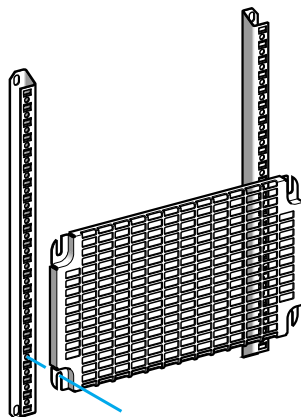

AM3-PA36

6

AF1-VA●●●

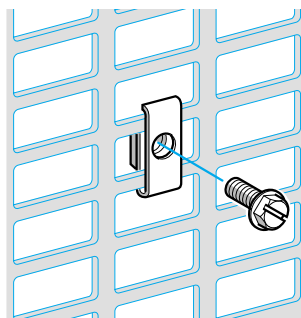

AF1-EA●

## Tornillos para la fijación de los aparatos

### Tuercas clips enganchables (2)

Tipo	Venta por cant. indiv.	Referencia unitaria	Peso kg
M3	100	AF1-EA3	0,005
M4	100	AF1-EA4	0,005
M5	100	AF1-EA5	0,008
M6	100	AF1-EA6	0,008

### Tornillos correspondientes (2)

Tipo	Venta por c. indiv.	Referencia unitaria	Peso kg
M4 × 10 (3)	100	AF1-VA410	0,002
M4 × 16 (3)	100	AF1-VA416	0,002
M5 × 12 (3)	100	AF1-VA512	0,003
M5 × 18 (3)	100	AF1-VA518	0,004
M6 × 12 (3)	100	AF1-VA612	0,005
M6 × 18 (3)	100	AF1-VA618	0,006

(1) En chapa de acero 20/10. Yuxtaposicionables, permiten una superficie máxima en toda la altura del chasis. Se montan en armarios AA2 y AA3.

(2) Acero zincado cromatado.

(3) Tornillos con arandela imperdible y cabeza hexagonal con ranura.

# Accesorios de montaje y de cableado

Placas perforadas Telequick

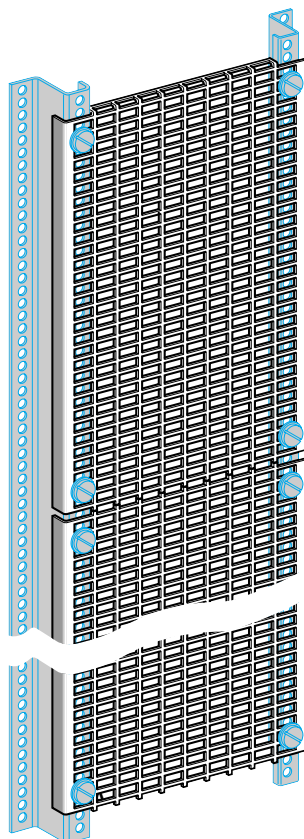

AM1-PA●●●

## Placas perforadas Telequick yuxtaposicionables tipo AM1-PA (1)

Estas placas perforadas de chapa de acero 20/10 zincada cromatada son yuxtaposicionables, lo que proporciona una superficie útil máxima en toda la altura del chasis.

Entreeje de fijación		Dimensiones totales		Superficie total dm <sup>2</sup>	Referencia	Peso kg
Anchura mm	Altura mm	Anchura mm	Altura mm			
400	60	434	120	5,2	AM1-PA0640 (3)	0,410
	120	434	180	7,8	AM1-PA1240 (3)	0,590
	300	434	360	15,5	AM1-PA3040	1,100
	600	434	660	28,5	AM1-PA6040	1,960
	900	434	960	41,5	AM1-PA9040	2,810
500	60	534	120	6,3	AM1-PA0650	0,510
	120	534	180	9,5	AM1-PA1250	0,720
	300	534	360	19,1	AM1-PA3050	1,360
	600	534	660	35,1	AM1-PA6050	2,410
	900	534	960	51,5	AM1-PA9050	3,470
600	60	634	120	7,6	AM1-PA0660 (3)	0,610
	120	634	180	11,4	AM1-PA1260 (3)	0,860
	300	634	360	22,7	AM1-PA3060	1,610
	600	634	660	41,7	AM1-PA6060	2,870
	900	634	960	60,7	AM1-PA9060	4,130
700	60	734	120	8,7	AM1-PA0670 (3)	0,660
	120	734	180	13,1	AM1-PA1270	0,940
	300	734	360	26,3	AM1-PA3070	1,760
	600	734	660	48,3	AM1-PA6070	3,130
	900	734	960	70,3	AM1-PA9070	4,490

## Placas perforadas Telequick (1)

### Para equipos de dimensiones reducidas

Entreeje de fijación		Dimensiones totales		Superficie total dm <sup>2</sup>	Referencia	Peso kg
Anchura mm	Altura mm	Anchura mm	Altura mm			
195	150	244	228	5,5	AM1-PA2015 (3)	0,450
300	150	349	228	7,9	AM1-PA3015 (3)	0,620
	195	349	258	9	AM1-PA3020	0,700
405	200	465	234	10,7	AM1-PA4020	0,890
	300	465	334	15	AM1-PA4030	1,220
495	300	555	334	18	AM1-PA5030	1,440
	400	555	434	24	AM1-PA5040	1,660
600	400	660	434	28	AM1-PA6040	1,960
	500	660	534	35	AM1-PA6050	2,410
705	500	765	534	40	AM1-PA7050	2,780
795	600	855	634	54	AM1-PA8060	3,690
900	700	960	734	70	AM1-PA9070	4,490

## Placas perforadas Telequick reforzadas (tornillos para fijación de los aparatos, ver la pág. al lado)

900	700	955	724	69	AM1-PS9070	4,620
1.095	700	1.150	724	83	AM1-PS11070	5,640

## Calzo (grosor: 10 mm) (2)

Utilización	Venta por cant. indiv.	Referencia unitaria	Peso kg
-------------	------------------------	---------------------	------------

Para fijación de la placa AM1-PA **4** **AZ1-CA04** 0,013

(1) Placas perforadas Telequick para montaje: (suministradas con 4 arandelas de fijación)  
 – en cofres aislantes estancos tipo ACP: ver la página 5/7 o tipo AC4,  
 – en armarios tipo AA4: ver las páginas 6/4 a 6/7.

(2) Acero zincado cromatado.

(3) Venta por cantidad indivisible: 10 piezas.

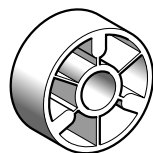

AZ1-CA04

# Accesorios de montaje y de cableado

Perfiles para la fijación de los aparatos

Catalogos en azul de entrega inmediata en planta

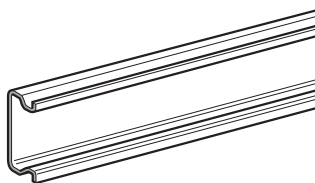

AM1-ED201

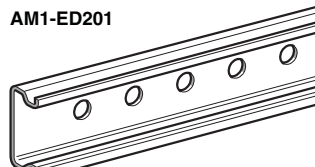

AM1-ED000

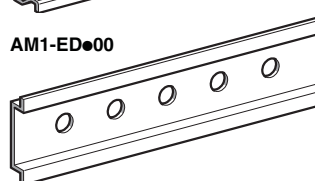

AM1-DP200

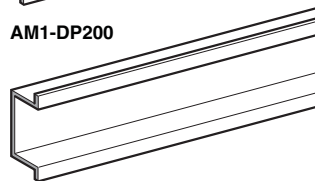

AM1-DE200

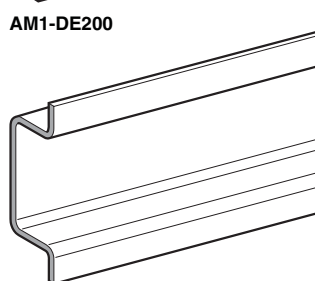

AM1-DL200

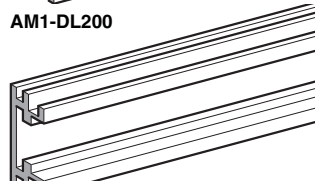

AM1-EA200

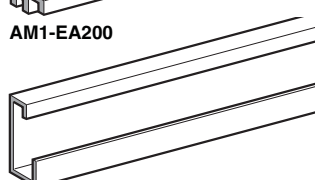

DZ5-MB01

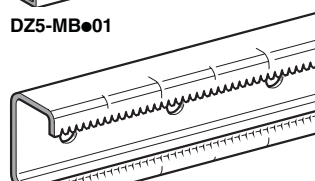

AM1-EC200

## Mediante enganche o atornillado

Anchura mm	Material y tratamiento de superficie mm	Pro- fundidad mm	Entreeje de fijación		Lon- gitud mm	Venta por c. indiv.	Referencia unitaria	Peso kg
			mínima mm	máxima mm				
<b>Perfiles combinados</b>								
35	Acero 15/10 <sup>e</sup> zincado cromatado	15	200	225	250	10	AM1-ED021	0,210
			300	325	350	10	AM1-ED031	0,310
			400	425	450	10	AM1-ED041	0,390
			500	525	550	10	AM1-ED051	0,480
			450	550	590	10	AM1-ED055	0,660
			600	625	650	10	AM1-ED061	0,580
			650	750	790	10	AM1-ED075	0,870
			700	725	750	10	AM1-ED071	0,670
			850	950	990	10	AM1-ED095	1,100
			1.050	1.150	1.190	10	AM1-ED115	1,320
(1)	(1)	(1)	2.000	10	AM1-ED201	2,200		
	Acero 10/10 <sup>e</sup> zincado cromatado	15	-	-	2.000	10	AM1-ED200	1,310

## Mediante enganche - Perfiles simétricos

35	Acero 10/10 <sup>e</sup> zincado cromatado	7,5	-	-	2.000	10	AM1-DP200	0,650
	galvanizado	7,5	-	-	2.000	10	AM1-DR200	0,650
35	Acero 15/10 <sup>e</sup> zincado cromatado	15	-	-	2.000	10	AM1-DE200	0,900
35	Aluminio 18/10 <sup>e</sup>	16	-	-	2.000	10	AM1-EA200	0,860
75	Acero 30/10 <sup>e</sup> zincado cromatado	25	-	-	2.000	4	AM1-DL200	5,200
75	Acero 20/10 <sup>e</sup> zincado cromatado	15	-	-	2.000	6	AM1-DL201	3,000

## Mediante atornillado

<b>Perfil asimétrico</b>								
32	Acero 15/10 <sup>e</sup> zincado cromatado	15	-	-	2.000	10	DZ5-MB201	1,500
<b>Perfil con muescas utilizado como soporte de aparellaje</b>								
40	Acero 20/10 <sup>e</sup> zincado cromatado	25	-	-	2.000	2	AM1-EC200	2,980

(1) Sin fijación predefinida, taladrado a cargo del usuario.

### Otras realizaciones

Herramienta de corte de los perfiles combinados.  
Consultarnos.Dimensiones:  
páginas 6/11 a 6/15

# Accesorios de montaje y de cableado

Tornillos para la fijación de los aparatos

## Sobre perfiles combinados AM1-ED

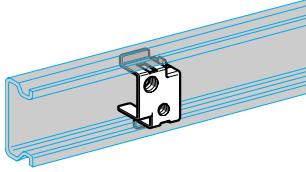

AF1-CF●●

Tornillos correspondientes (1)			
Tipo	Venta por cant. indiv.	Referencia unitaria	Peso kg
M3 y M4	100	AF1-CF34	0,010
M5 y M6	100	AF1-CF56	0,010

Tornillos correspondientes (1)			
Tipo	Venta por cant. indiv.	Referencia unitaria	Peso kg
M4 × 10 (2)	100	AF1-VA410	0,002
M4 × 16 (2)	100	AF1-VA416	0,002
M5 × 12 (2)	100	AF1-VA512	0,003
M5 × 18 (2)	100	AF1-VA518	0,004
M6 × 12 (2)	100	AF1-VA612	0,005
M6 × 18 (2)	100	AF1-VA618	0,006

## Sobre perfiles simétricos AM1-DE o DP o bien sobre perfiles combinados AM1-ED

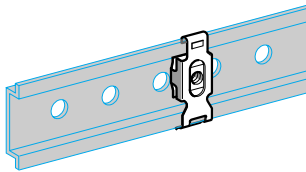

AF1-CG●●

Tornillos correspondientes (1)			
Tipo	Venta por cant. indiv.	Referencia unitaria	Peso kg
M4	100	AF1-CG4	0,007
M5	100	AF1-CG5	0,007
M6	100	AF1-CG6	0,007

Tornillos correspondientes (1)			
Tipo	Venta por cant. indiv.	Referencia unitaria	Peso kg
M4 × 10 (2)	100	AF1-VA410	0,002
M4 × 16 (2)	100	AF1-VA416	0,002
M5 × 12 (2)	100	AF1-VA512	0,003
M5 × 18 (2)	100	AF1-VA518	0,004
M6 × 12 (2)	100	AF1-VA612	0,005
M6 × 18 (2)	100	AF1-VA618	0,006

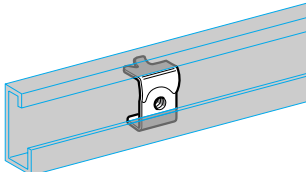

DZ5-ME●

## Sobre perfiles asimétricos DZ5-MB

Tornillos correspondientes (1)			
Tipo	Venta por cant. indiv.	Referencia unitaria	Peso kg
M4	100	DZ5-ME8	0,009
M5	100	DZ5-ME9	0,009
M6	100	DZ5-ME5	0,009

Tornillos correspondientes (1)			
Tipo	Venta por cant. indiv.	Referencia unitaria	Peso kg
M4 × 10 (2)	100	AF1-VA410	0,002
M4 × 16 (2)	100	AF1-VA416	0,002
M5 × 12 (2)	100	AF1-VA512	0,003
M5 × 18 (2)	100	AF1-VA518	0,004
M6 × 12 (2)	100	AF1-VA612	0,005
M6 × 18 (2)	100	AF1-VA618	0,006

## Sobre perfiles con muescas AM1-EC

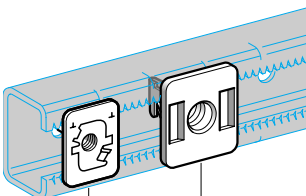

AF1-CD061

AF1-CD6

Tornillos correspondientes (1)			
Tipo	Venta por cant. indiv.	Referencia unitaria	Peso kg
M6	10	AF1-CD061	0,020
M8	10	AF1-CD081	0,020
M10	10	AF1-CD101	0,020

Tornillos correspondientes (1)			
Tipo	Venta por cant. indiv.	Referencia unitaria	Peso kg
M6 × 12 (2)	100	AF1-VA612	0,005
M6 × 18 (2)	100	AF1-VA618	0,006
M8 × 20 (3)	10	AF1-VC820	0,024
M10 × 20 (4)	10	AF1-VC10	0,033

Tornillos correspondientes (1)			
Tipo	Venta por cant. indiv.	Referencia unitaria	Peso kg
M6	10	AF1-CD6	0,053
M8	10	AF1-CD8	0,053
M10	10	AF1-CD10	0,053

Tornillos correspondientes (1)			
Tipo	Venta por cant. indiv.	Referencia unitaria	Peso kg
M6 × 12 (2)	100	AF1-VA612	0,005
M6 × 18 (2)	100	AF1-VA618	0,006
M8 × 20 (3)	10	AF1-VC820	0,024
M10 × 20 (4)	10	AF1-VC10	0,033

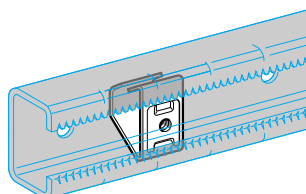

AF1-CH5

Tornillos correspondientes (1)			
Tipo	Venta por cant. indiv.	Referencia unitaria	Peso kg
M5	10	AF1-CH5	0,006

Tornillos correspondientes (1)			
Tipo	Venta por cant. indiv.	Referencia unitaria	Peso kg
M5 × 12 (2)	100	AF1-VA512	0,003
M5 × 18 (2)	100	AF1-VA518	0,004

Tornillos correspondientes (1)			
Tipo	Venta por cant. indiv.	Referencia unitaria	Peso kg
M4,8 × 16	100	AF1-VT516	0,003
M6 × 10	100	TA1-ZL02	0,003

Tornillos correspondientes (1)			
Tipo	Venta por cant. indiv.	Referencia unitaria	Peso kg
M4,8 × 16	100	AF1-VT516	0,003
M6 × 10	100	TA1-ZL02	0,003

(1) Tornillo de cabeza cilíndrica hexagonal y arandela de freno.  
 (2) Tornillo con arandela imperdible y cabeza hexagonal con ranura.  
 (3) Tornillo de cabeza hexagonal con arandela de contacto.  
 (4) Tornillo de cabeza cilíndrica hexagonal y arandela de freno.  
 (5) Acero zincado cromatado, caja de tuerca inox.

### Fondo de canaletas. Color: azul RAL 5000

En PVC rígido con ranuras laterales de salida y perforaciones en el fondo. Conformidad con las normas NF C 68-102.

Longitud: 2 m (3)

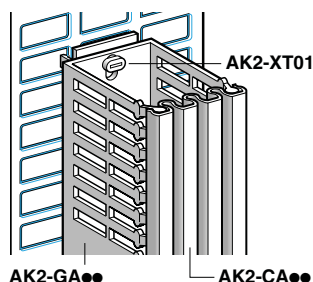

Fijación	Anchura mm	Altura mm	Capacidad (1) en hilos de 1,5 mm <sup>2</sup>	Venta por cantidad indivisible	Referencia unitaria	Peso kg
Mediante enganche o o atornillado sobre placa o perfil "simétrico" de 35 mm o "combinado"	30	35	60	8	AK2-GA33	0,500
		55	110	8	AK2-GA35	0,800
		90	200	8	AK2-GA39	1,120
	60	55	230	8	AK2-GA65	0,900
		90	400	8	AK2-GA69	1,200
	120	80	700	8	AK2-GC128	1,410
Sobre 1 montante DZ6-MZ	30	144	340	8	AK2-GA315	1,600
Entre 2 montantes DZ6-MZ	60	144	550	8	AK2-GA615	1,700

### Tapas de canaletas. Color: azul RAL 5.000 (PVC rígido de 2 m de longitud) (3)

Utilización	Venta por cant. indiv.	Referencia unitaria	Peso kg
Para canaletas	AK2-GA33, GA35, GA39, GA315	AK2-CA3	0,200
	AK2-GA65, GA69, GA615	AK2-CA6	0,430
	AK2-GC128	AK2-CC12	0,610

### Pie de soporte para fijación de los fondos de las canaletas (poliamida negra) (2)

Fijación por enganche	Utilización para fondos de canaletas perforadas	Venta por cant. indiv.	Referencia unitaria	Peso kg
Sobre placa perforada o sobre perfil "simétrico" de 35 mm o "combinado"	AK2-GA (azul RAL 5.000) ou AK2-GD (gris RAL 7030)	20	AK2-XT01	0,010

Este pie de soporte incluye un dispositivo de enclavamiento que fija los fondos de las canaletas a las perforaciones de Ø 6,5 x 14 mm.

### Fondo de canaletas. Color: gris RAL 7030

De PVC rígido con ranuras laterales de salida y perforaciones en el fondo, de 2 m de longitud. Conformidad con las normas: VDE 0660/506 y DIN 43659 (3)

Fijación	Longitud mm	Altura mm	Capacidad (1) en hilos de 1,5 mm <sup>2</sup>	Venta por cantidad indivisible	Referencia unitaria	Peso kg
Mediante enganche o atornillado sobre placa o perfil "simétrico" de 35 mm o "combinado"	25	25	25	8	AK2-GD2525	0,260
		50	65	8	AK2-GD2550	0,460
	37,5	50	110	8	AK2-GD3750	0,520
		75	160	8	AK2-GD3775	0,800
	50	50	160	8	AK2-GD5050	0,600
		75	240	8	AK2-GD5075	0,880
	75	50	250	8	AK2-GD7550	0,880
		75	400	8	AK2-GD7575	1,040
	100	75	550	8	AK2-GD10075	1,200
	125	75	700	8	AK2-GD12575	1,360

### Tapas de canaletas. Color: gris RAL 7030 (PVC rígido de 2 m de longitud) (3)

Utilización	Venta por cant. indiv.	Referencia unitaria	Peso kg
Para fondos de canaletas	AK2-GD2525, GD2550	AK2-CD25	0,160
	AK2-GD3750, GD3775	AK2-CD37	0,220
	AK2-GD5050, GD5075	AK2-CD50	0,280
	AK2-GD7550, GD7575	AK2-CD75	0,380
	AK2-GD10075	AK2-CD100	0,480
	AK2-GD12575	AK2-CD125	0,600

(1) Capacidad máxima de hilos flexibles H07-V-K/1,5 mm<sup>2</sup>. Se recomienda aplicar un coeficiente de llenado de 0,60, sin tener en cuenta dilataciones ni cruces de hilos en las intersecciones de las canaletas.

(2) Comportamiento al fuego: material VO de conformidad con UL 94.

(3) Resistencia de temperatura: -5...+60 °C. Comportamiento al fuego: material VO de conformidad con UL 94.



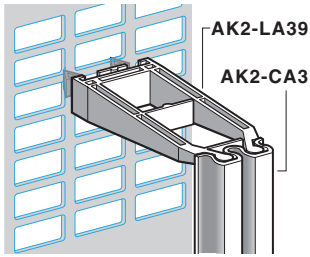

### Liras. Color: negro (1)

Enganche	Entreeje en mm	Capacidad en hilos de 2,5 mm <sup>2</sup>	Venta por cant. indiv.	Referencia unitaria	Peso kg
<b>Sobre placa perforada Telequick®</b>	–	90	10	<b>AK2-LA39</b>	0,009
<b>Sobre perfil “simétrico” de 35 mm o sobre perfil combinado</b>	–	75	10	<b>AK2-LD02</b>	0,009
		90	10	<b>AK2-LD01</b>	0,009
<b>Entre 2 perfiles asimétricos</b>	60	75	10	<b>AK2-LB23</b>	0,009

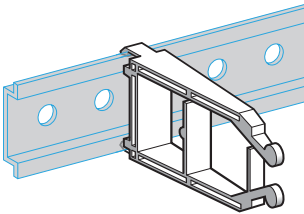

AK2-LD01

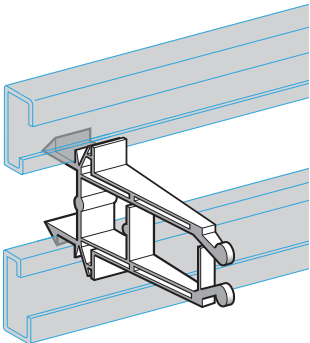

AK2-LB23

### Tapas para liras. Color: azul RAL 5000 (PVC rígido de 2 m de longitud)

Utilización		Venta por cant. indiv.	Referencia unitaria	Peso kg
<b>Para liras</b>	AK2-LA39 (2), LD01 LD02, LB23	8	<b>AK2-CA3</b>	0,200

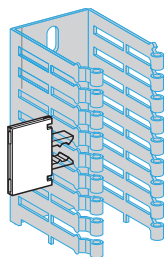

AR1-SA3

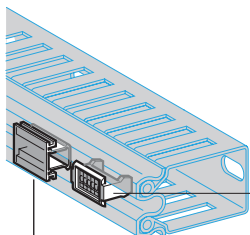

AR1-SB339187

AR1-SA2

### Auxiliares de referenciado

Designación	Venta por cant. indiv.	Referencia unitaria	Peso kg
<b>Portaetiquetas</b> translúcido con papel suministrado (1) enganchable en tapas AK2-CA	10	<b>AR1-SB339187</b>	0,001
<b>Portarreferencias</b> negro para 6 referencias enganchables AB1-R o G (1) enganchable en tapas AK2-CA	100	<b>AR1-SA2</b>	0,001
<b>Portarreferencias adhesivo</b> (gris RAL 7032) para 6 referencias enganchables AB1-R o G (para tapas de canaletas AK2-CD)	50	<b>AR1-SB3</b>	0,001
<b>Portaetiquetas</b> (3) transparente enganchable sobre alas de canaleta AK2-GD (etiquetas de papel suministradas)	50	<b>AR1-SA3</b>	0,005

(1) Poliamida.

(2) Estas liras, enganchadas en tresbolillo sobre placa perforada, pueden recibir las tapas AK2-CA6.

(3) Policarbonato.

#### Otras realizaciones

Liras de capacidad en hilos diferentes y tapas correspondientes. Consultarnos.

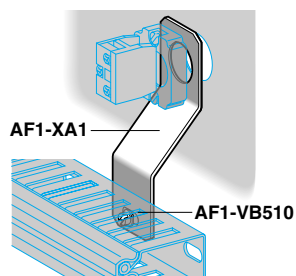

AF1-XA1

AF1-VB510

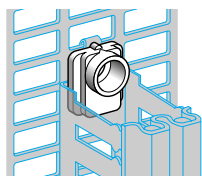

AF1-BA1

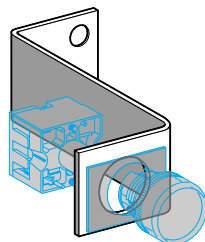

DX1-AP5

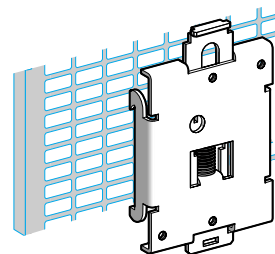

AX2-DL0

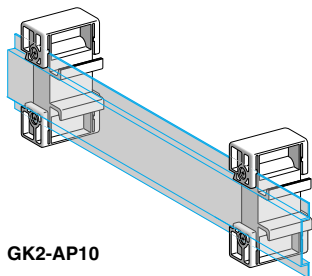

GK2-AP10

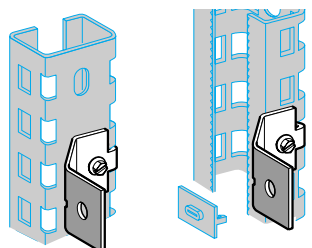

AF1-XC3

Dimensiones:  
página 6/15

## Accesorios de fijación

Designación	Venta por cant. indiv.	Referencia unitaria	Peso kg
<b>Soporte metálico de canaletas</b> para unidades de control y señalización Ø 22, montadas en puerta de cofre o de armario (1) (fijación posible mediante tuercas-clips AF1-EA5, ver la pág. 6/4)	10	<b>AF1-XA1</b>	0,030
<b>Tornillo M5×10</b> , de cabeza aislada hexagonal ranurada, para fijación de las canaletas	100	<b>AF1-VB510</b>	0,003
<b>Brida</b> para fijación de canaletas o de perfiles por pinzamiento (2) (fijación de la brida al soporte mediante tornillo M6 no suministrado)	10	<b>AF1-BA1</b>	0,003
<b>Soporte</b> para unidades de control (1) (Ø 31) sobre perfil DIN	10	<b>DX1-AP51</b>	0,160
<b>Soporte</b> para unidades de control (1) (Ø 22) sobre perfil DIN	10	<b>DX1-AP52</b>	0,160
<b>Placa de soporte</b> para equipos con tornillos (1) (montaje sobre perfiles simétricos de 35, combinados o placa Telequick)	10	<b>AX2-DL01</b>	0,060
		<b>AX2-DL02</b>	0,060
<b>Realce ajustable</b> (Profundidad del envolvente: hasta 300 mm)	2	<b>GK2-AP10</b>	0,100

## Patilla de fijación para pie de canaletas

Fijación mediante atornillado	Utilización para pie de canaletas	Material tratamiento grosor	Venta por cant. indiv.	Referencia unitaria	Peso kg
<b>Escuadra metálica</b> para montaje del pie de canaleta sobre montante perfor. con muescas AM3-EC	AK2-XT01	Chapa de acero galvanizada 20/10°	10	<b>AF1-XC3</b>	0,050

- (1) Zincado cromatado.
- (2) Poliamida.
- (3) Mediante tuerca AA3-AA06 y tornillo AF1-VA612.
- (4) Mediante tuerca AF1-EA6 y tornillo AF1-VA612.

Montantes y perfiles AM1-EC●●●

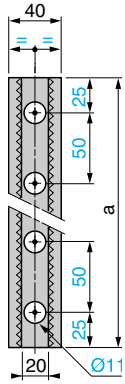

Montantes perforados con muescas AM3-EC●●●

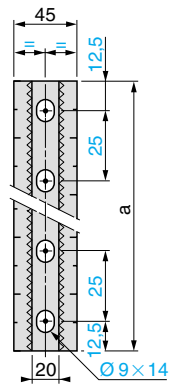

Montantes perforados DZ6-MZ●●●

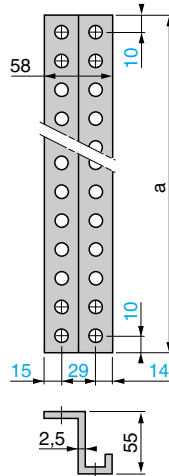

Montantes y perfiles

AM1-EC	090	115	200
a	900	1.150	2.000

Montantes perforados con muescas

AM3-EC	105	145	165	185
a	1.075	1.475	1.675	1.875

Montantes perforados

DZ6-MZ	121	151	161	181	200	211
a	1.020	1.320	1.420	1.620	1.820	1.920

Perfiles combinados AM1-ED0●1

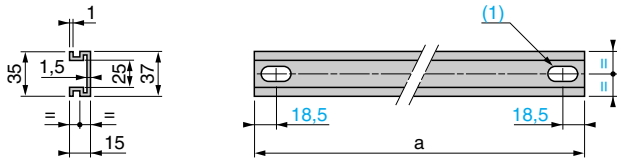

AM1-	ED021	ED031	ED041	ED051	ED061	ED071
a	250	350	450	550	650	750

(1) 2 taladros rasgados 6,5×19

Perfiles combinados AM1-ED●5

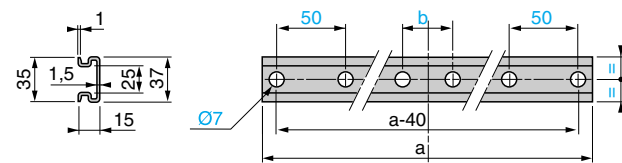

AM1-	ED055	ED075	ED095	ED115
a	590	790	990	1190
b	-	-	150	150
N.º de tuercas Ø7	4	4	6	6

Perfil combinado AM1-ED201

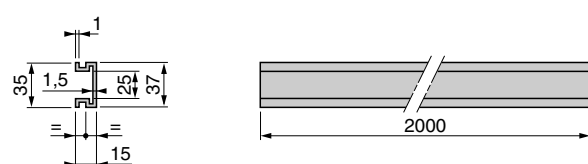

Perfiles combinados AM1-ED200

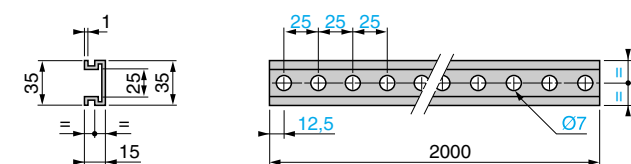

Perfil de aluminio AM1-EA200



Perfil simétrico AM1-DP200, DR200

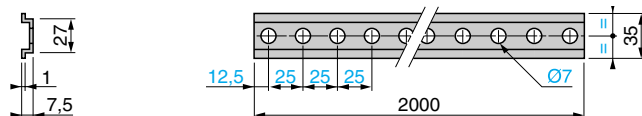

Perfil simétrico AM1-DE200

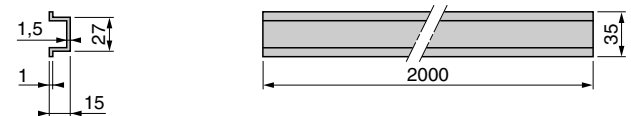

Perfil simétrico AM1-DL200, DL201, vista frontal común

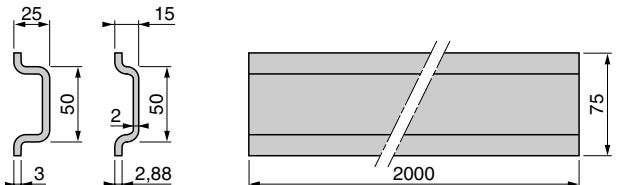

Perfil asimétrico DZ5-MB201

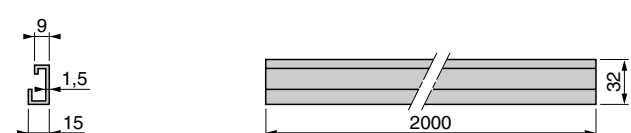

Referencias:  
páginas 6/2 a 6/6

# Accesorios de montaje y de cableado

Placas perforadas

Placas perforadas Telequick yuxtaposicionables sobre montantes AM3-EC  
AM3-PA●●●●

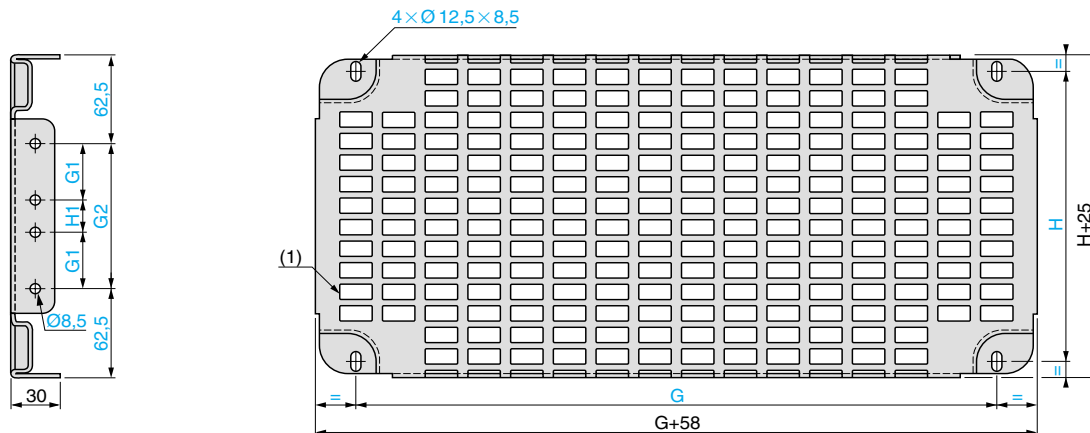

AM3-PA	2045	2065	2085	20105	4045	4065	4085	40105	6045	6065	6085	60105	8045	8065	8085	80105
G	450	650	850	1050	450	650	850	1050	450	650	850	1050	450	650	850	1050
G1	-	-	-	-	-	-	-	-	125	125	125	125	250	250	250	250
G2	100	100	100	100	325	325	325	325	475	475	475	475	700	700	700	700
H	200	200	200	200	425	425	425	425	575	575	575	575	800	800	800	800
H1	-	-	-	-	-	-	-	-	225	225	225	225	200	200	200	200

(1)  $\square 11 \times 26$  con paso de  $15 \times 30$ .

Placas perforadas  
AM3-PA●●●●

6

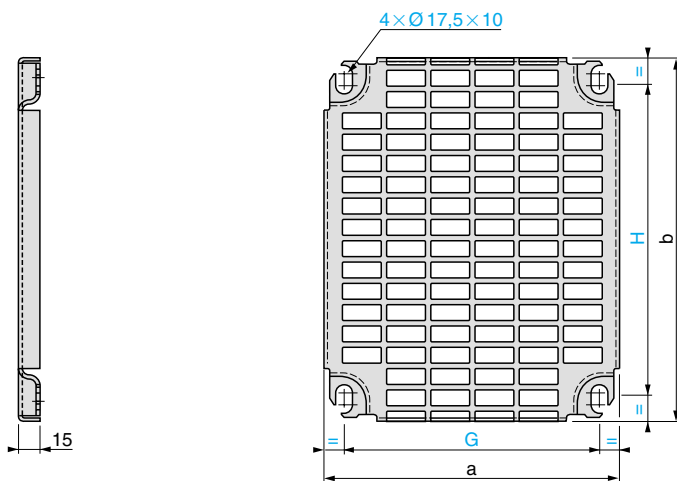

AM3-PA	32 (2)	325	36	38	425	43	44	53	54	64	65	66
a	154	228	551	751	228	251	351	251	351	351	451	551
b	255	253	255	255	349	349	345	454	450	555	555	555
G	125	175	525	725	175	225	325	225	325	325	425	525
H	225	225	225	225	325	325	325	425	425	525	525	525

AM3-PA	75	76	86	88	97	108	128
a	451	551	551	751	651	751	751
b	645	645	750	750	855	945	1145
G	425	525	525	725	625	725	725
H	625	625	725	725	825	925	1125

(1)  $\square 11 \times 26$  con paso de  $15 \times 30$ .

(2) Sin pliego ni reborde.

Referencias:  
página 6/4

Placa perforadas Telequick  
AM1-PA2015

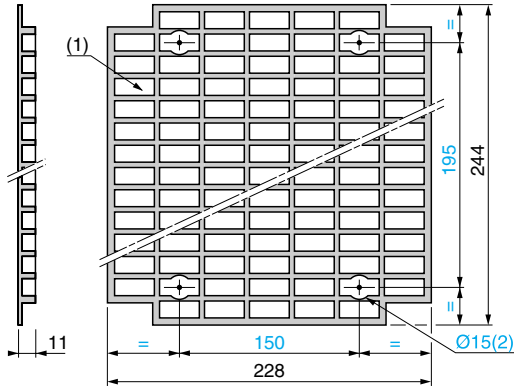

AM1-PA3015

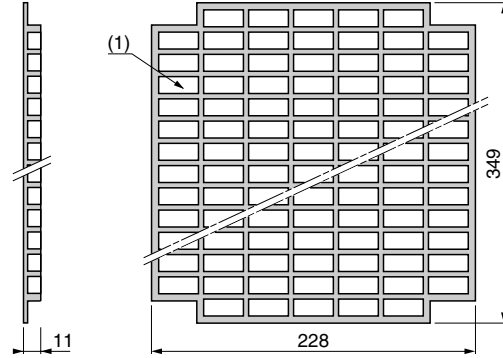

AM1-PA3020

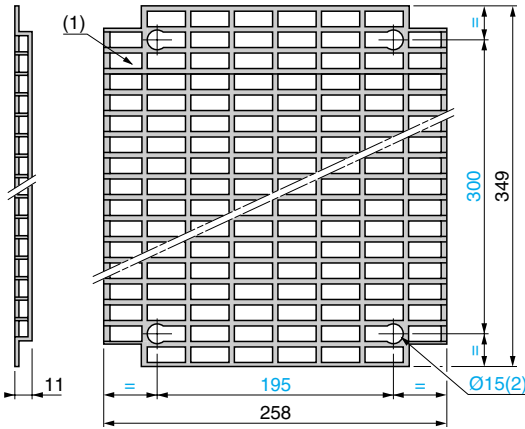

AM1-PA4000, 5000, 6000, 7050, 8060, 9070

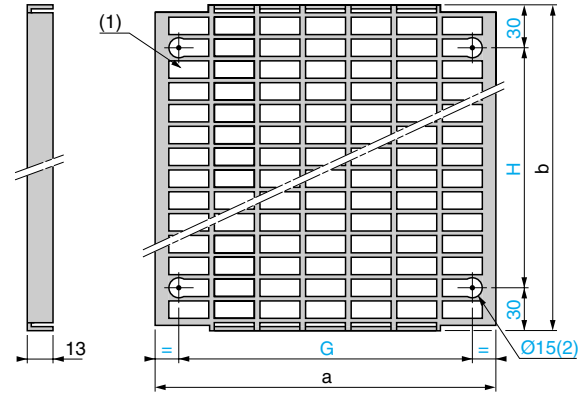

(1)  $\varnothing 11 \times 26$  con paso de  $15 \times 30$ .  
(2)  $\varnothing 15$  para arandelas de centrado.

Placas perforadas Telequick yuxtaposicionables sobre montantes DZ6-MZ AM1-PA0000

AM1-PA	4020	4030	5030	5040	6040	6050	7050	8060	9070
a	234	334	334	434	434	534	534	634	734
b	465	465	555	555	660	660	765	855	960
G	200	300	300	400	400	500	500	600	700
H	405	405	495	495	600	600	705	795	900

Placas perforadas Telequick reforzadas  
AM1-PS0000

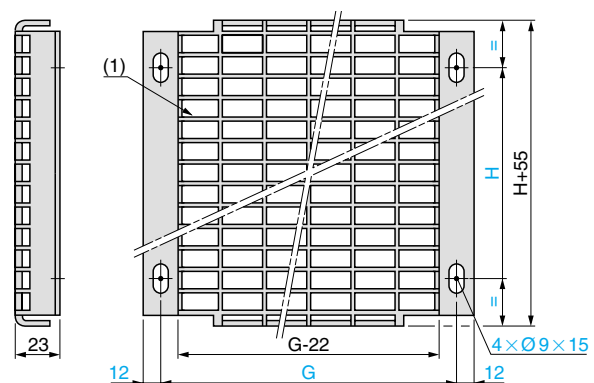
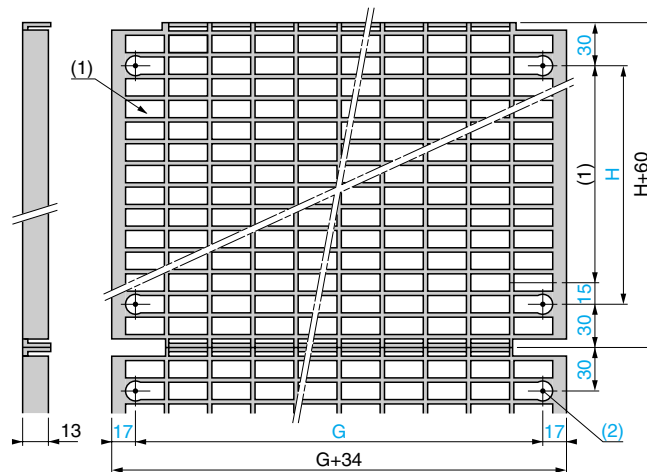

AM1-PA	0640	0650	0660	0670	1240	1250	1260	1270	3040	3050
G	400	500	600	700	400	500	600	700	400	500
H	60	60	60	60	120	120	120	120	300	300
AM1-PA	3060	3070	6040	6050	6060	6070	9040	9050	9060	9070
G	600	700	400	500	600	700	400	500	600	700
H	300	300	600	600	600	600	900	900	900	900

(1)  $\varnothing 11 \times 26$  con paso de  $15 \times 30$ .

(2)  $\varnothing 15$  para arandelas de centrado.

Referencias:  
página 6/5

# Accesorios de montaje y de cableado

Auxiliares de cableado

**Canaletas**  
**AK2-GA●●●**

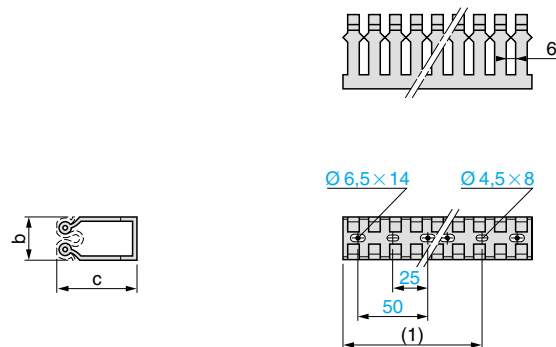

AK2-	GA33	GA35	GA65	GA39	GA69	GA315	GA615
b	30	30	60	30	60	30	60
c	35	55	55	90	90	144	144

(1) 2.000 (paso de 15).

**Canaletas**  
**AK2-GC128, GD75●●, GD1●●75**

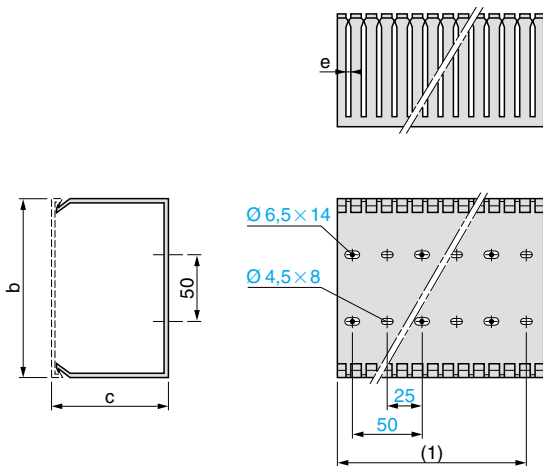

AK2-	GC128	GD7550	GD7575	GD10075	GD12575
b	120	73	73	98	123
c	80	48	73	73	73
e	4	5	5	5	5

(1) 2000 - AK2-GC128: paso de 10, AK2-GD: paso de 12,5.

**Liras**  
**AK2-LA39**

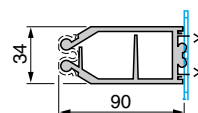

**AK2-LD0●**

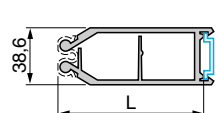

AK2-	LD02	LD01
L	85	103

**AK2-GD25●●, GD37●●, GD50●●**

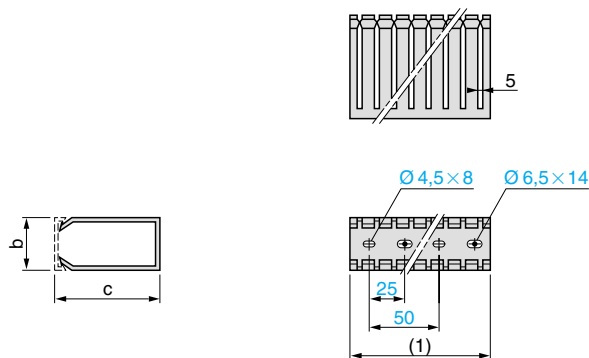

AK2-	GD2525	GD2550	GD3750	GD3775	GD5050	GD5075
b	23	23	35,5	35,5	48	48
c	23	48	48	73	48	73

(1) 2.000 (paso de 12,5).

**Pie soporte de canaletas**  
**AK2-XT01**

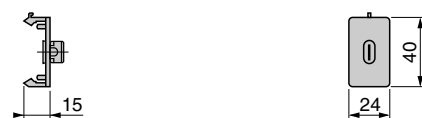

**Soporte de canaletas**  
**AF1-XA1**

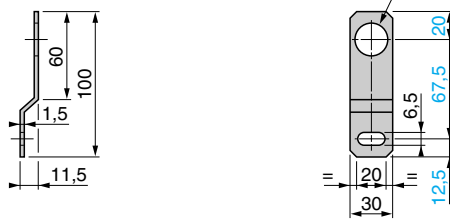

6

Placas de soporte  
AX2-DL01

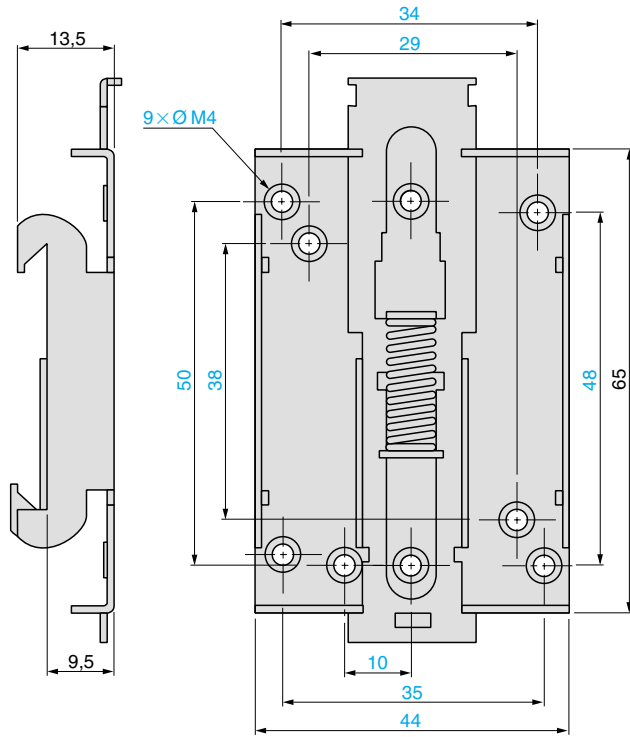

AX2-DL02

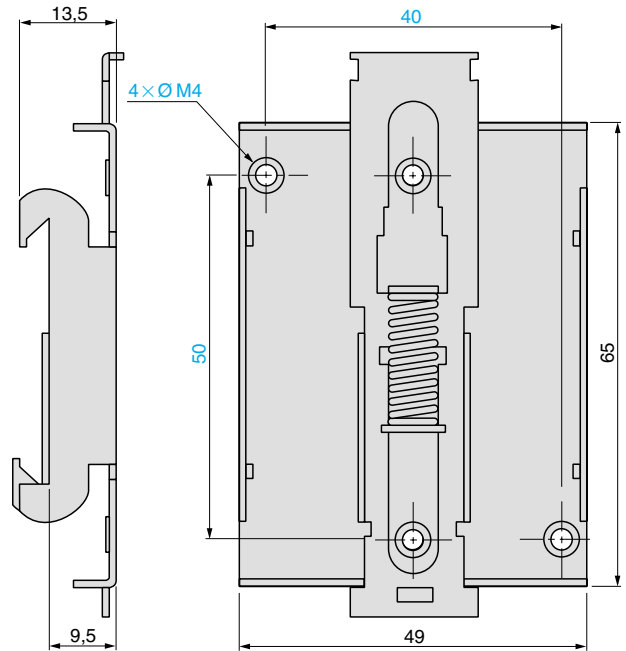

Soportes para unidad de control  $\varnothing 22$  y  $\varnothing 31$   
DX1-AP52

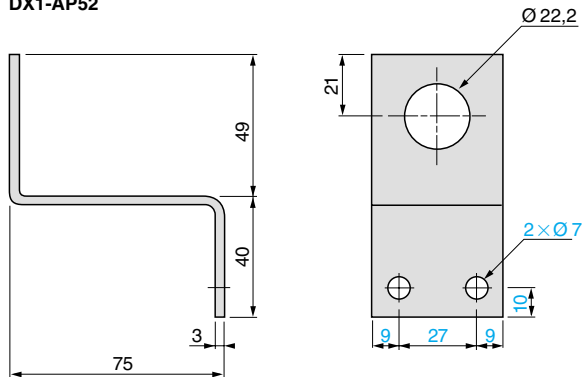

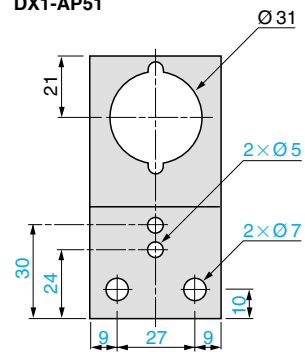

DX1-AP51

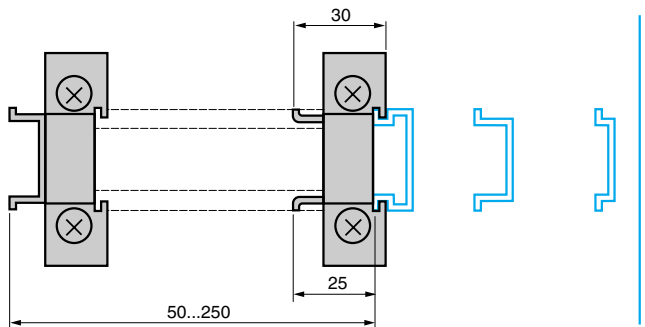

Realce ajustable  
GK2-AP10



Application	Single-pole splitter system	Horizontal busbar system
		
<b>Type</b>	<p>Single-pole splitter block</p> <ul style="list-style-type: none"> <li>- 1 upstream cable connection (35 mm<sup>2</sup> solid or 25 mm<sup>2</sup> flexible cable),</li> <li>- 6 downstream cable connections (up to 6 mm<sup>2</sup> solid or 4 mm<sup>2</sup> flexible cables).</li> </ul>	<p>Complete busbar system for the distribution of current using removable tap-off units or component mounting plates incorporating an electrical tap-off.</p>
<b>Composition</b>	<p>Single-pole splitter block incorporating universal fixing for clipping onto 35, 32, 25, 16, 10, 6, 4 mounting rails and Tequick pre-slotted mounting plates.</p>	<ul style="list-style-type: none"> <li>- 1 set of prefabricated 4-pole busbars comprising 12 to 54 tap-off outlets (depending on model) and incorporating an incoming supply terminal block.</li> <li>- Prefabricated removable 16 and 32 A tap-offs, either 2-pole, 3-pole, 4-pole or 3-pole + common.</li> <li>- Mounting plates for 1 or 2 components providing both electrical supply (25 and 50 A) and support for all types of equipment.</li> <li>- Width extension plates for use with the above mounting plates, for building more complex equipment.</li> </ul>
<b>Features</b>	<ul style="list-style-type: none"> <li>- Compact size.</li> <li>- Suitable for control circuits.</li> <li>- Can be referenced using AB1 clip-in markers.</li> <li>- Degree of protection IP 20.</li> </ul>	<ul style="list-style-type: none"> <li>- Prefabricated busbar system suitable for all types of equipment, with possibility of adding or modifying outgoing loads, quite safely, under live circuit conditions.</li> <li>- Degree of protection IP20.</li> </ul>
<b>Rating</b>	90 A	160 A
<b>References</b>	<b>AB3</b>	<b>AK5</b>
<b>Pages</b>	13231/3	13231/2



**Horizontal and vertical distribution system**



Sub-assemblies and accessories for mounting and cabling to copper busbar sets (thickness 5 mm, height 12 to 60 mm).

- Insulated busbar supports for 3 or 4-pole systems (busbars not supplied).
- Screw clamp connectors that clamp directly onto the copper busbars (no drilling required).
- Connector plates and associated clamps.
- Protective cover.
- Single-pole splitter block that clamps directly onto the copper busbar (no drilling required) enabling up to 6 cables to be tapped off.

- Sub-assemblies enabling variable composition by the customer to suit a wide range of application needs.
- Screw clamp connectors and splitter blocks clamp directly onto the copper busbars (no drilling required).

200 to 690 A

**AK2**

13211/2

**Vertical and horizontal distribution system**

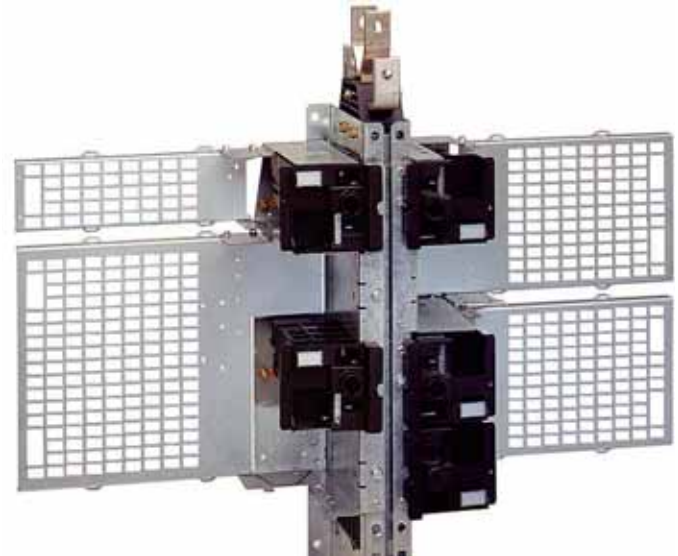

Complete prefabricated plug-in busbar system for supply of power to several partitioned individual starters.

- 1 set of 3 or 4-pole busbars, height 1800 mm, comprising 32 tap-off outlets (16 on each side).
- Disconnect blocks rated at 125 and 250 A, 3-pole + N + PE.
- Pre-slotted mounting plates for components.
- Operating key ensuring operation of stab connectors incorporated in the disconnect block.
- Available as an option: partitioning accessories and extra lateral supports for mounting plates.

- Self-supporting 1800 mm high metal-cased busbar system (for other sizes, please consult your Regional Sales Office.)
- Very easy to modify under live circuit conditions.
- Degree of protection IP20.

400 and 800 A

**AK3**

13221/2

# Power distribution in control panels

## Busbar systems: for horizontal and vertical power distribution

Busbar system characteristics								
Copper busbars	Dimensions	mm	12 x 5	20 x 5	30 x 5	40 x 5	50 x 5	60 x 5
Permissible current in the busbars (1)	Conforming to DIN 43671 at ambient temperature 35 °C <i>(1) Coefficient K to be applied according to the ambient temperature</i>	A	200	270	380	480	580	690
		°C	20	25	35	45	55	65
		K	1.14	1.1	1	0.9	0.7	0.6
Maximum let-through energy: I <sup>2</sup> t		A <sup>2</sup> s	70.10 <sup>6</sup>	180.10 <sup>6</sup>	370.10 <sup>6</sup>	560.10 <sup>6</sup>	780.10 <sup>6</sup>	1000.10 <sup>6</sup>

Permissible peak current in the busbars depending on the distance between supports (2)

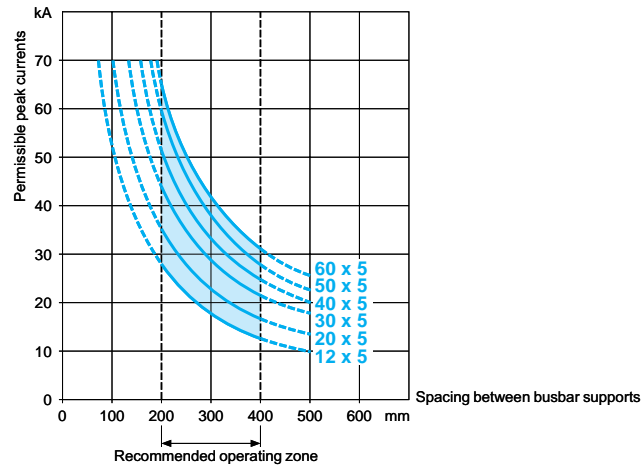

(2) To withstand the peak currents indicated, the cables must be securely clamped within a maximum distance of 250 mm from the busbar centres.

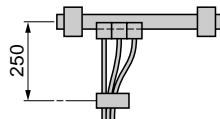

Screw clamp connector characteristics	
Rated insulation voltage	~ 750 V conforming to NF C 20-040 and VDE 0-110
Vibration resistance	10...55 Hz, amplitude 1 mm conforming to NF C 63-065
Flame resistance	960 °C conforming to NF C 20-455 VO for all plastic components conforming to UL 94
Electric shock protection	Insulated housing to protect against accidental contact with live parts, markable with 5 AB1-R or G markers
3-phase short-circuit current withstand	1 terminal: 25 kA (peak) 2 associated terminals: 50 kA (peak)

**Characteristics of single-pole splitter blocks AK2 and AB3**

<b>Rated insulation voltage (Ui)</b>	~ 750 V conforming to NF C 20-040 ~ 600 V conforming to CSA
<b>Vibration resistance</b>	10...55 Hz, amplitude 1 mm, conforming to NF C 63-065
<b>Flame resistance</b>	VO conforming to UL 94
<b>Enclosure material and colour</b>	Polyamide 6.6, grey RAL 7032
<b>Mounting</b>	<b>AB3-RV162:</b> clip-on mounting on $\perp$ , $\perp$ , $\perp$ rails and on Telequick pre-slotted mounting plates.
<b>Upstream connection</b>	
<b>AK2-BA162U</b>	On 5 or 6 mm thick copper bar by means of screw clamp connector. Tightening torque: 10 mN
<b>AB3-RV162U</b>	For flexible copper cable with cable end, from 4 to 25 mm <sup>2</sup> For solid cable from 6 to 35 mm <sup>2</sup>
<b>Downstream connection</b>	6 screw connectors, size 4 conforming to NF C 63-062 Connector capacity (conforming to § 8.2.4.3 of standard IEC 947.1): - solid conductor: 1 to 6 mm <sup>2</sup> - flexible conductor with cable end: 0.34 to 1 mm <sup>2</sup> (1 or 2 wires) – 1.5 to 2.5 mm <sup>2</sup> (1 wire)  Rated current: $I_e = 25 \text{ A} \times 6$ Screw heads protected by removable markable cover
<b>Marking</b>	By 6 <b>AB1-R</b> or <b>AB1-G</b> clip-in markers upstream and/or 4 <b>AB1-R</b> or <b>AB1-G</b> clip-in markers for each tap-off outlet.

**Assembly recommendations**

<b>Screw clamp connector AK2-BA01</b>	On copper bar only Connection of copper cables fitted with cable ends.
<b>Connector plate AK2-SP</b>	Chamfered face in contact with the clamp of the screw clamp connector.

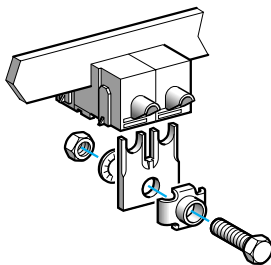

Terminal clamp AK2-SE with screws, washers and nuts.

<b>Terminal clamp AK2-SE</b>	For two cables of similar c.s.a.	C.s.a. mm <sup>2</sup>		Type of clamp required	
		min.	max.		
		6	16		AK2-SE20
		16	35		AK2-SE25
		16	50		AK2-SE30
<b>Cable c.s.a. adapter AK2-SC01 for use under terminal clamp</b>	For two cables of substantially different c.s.a.	C.s.a. mm <sup>2</sup> with adapter			
		min.	max.		
		1...4	6...16		
		1...6	16...35		
		1...10	16...50		
	1...16	25...95			





### Insulated busbar supports

Application	Busbar dimensions mm	Kit reference	Weight kg
For 3 or 4-pole busbar systems	12 x 5 or 20 x 5	<b>AK2-SB31</b>	0.250
	30 x 5 or 40 x 5	<b>AK2-SB32</b>	0.265
	50 x 5 or 60 x 5	<b>AK2-SB33</b>	0.270

The pre-assembled kit comprises 2 insulated supports, 3 insulated tubes, 2 Allen head screws, 2 H6 nuts. Suitable for mounting on AM1-P pre-slotted plates or  $\perp$ ,  $\lrcorner$  or  $\llcorner$  mounting rails using M6 screws.

### Copper bars (for use with insulated busbar supports)

Dimensions	mm	12 x 5	20 x 5	30 x 5	40 x 5	50 x 5	60 x 5
Permissible current conforming to DIN 43671	<b>A</b>	200	270	380	480	580	690

### Associated screw clamp connector

Application	Sold in lots of	Unit reference	Weight kg
For clamping onto 5 mm thick copper bar, without drilling and with maximum capacity of 2 x 10 mm <sup>2</sup> cables with cable ends. Markable with 5 AB1-R or AB1-G clip-in markers	12	<b>AK2-BA01</b>	0.050

### Connector plates

Width mm	Maximum tap-off current A	Fixing on	Sold in lots of	Unit reference	Weight kg
20	200	1 screw clamp connector	10	<b>AK2-SP20</b>	0.020
30	600	2 associated screw clamp connectors	10	<b>AK2-SP30</b>	0.050
40	700	2 associated screw clamp connectors	10	<b>AK2-SP40</b>	0.090

### Terminal clamps

Application	Fixing on	Sold in lots of	Unit reference	Weight kg
For 2 cables from 6 to 16 mm <sup>2</sup>	20 mm connector plate, M8 screws (not supplied)	20	<b>AK2-SE20</b>	0.005
For 2 cables from 16 to 35 mm <sup>2</sup>	30 mm connector plate, M10 screws (not supplied)	20	<b>AK2-SE25</b>	0.010
For 2 cables from 16 to 50 mm <sup>2</sup>	30 mm connector plate, M10 screws (not supplied)	20	<b>AK2-SE30</b>	0.010
For 2 cables from 25 to 95 mm <sup>2</sup>	40 mm connector plate, M12 screws (not supplied)	20	<b>AK2-SE40</b>	0.020

### Single-pole splitter blocks

Cabling Upstream	Downstream	Sold in lots of	Unit reference	Weight kg
6 flexible cables up to 2.5 mm <sup>2</sup> with cable ends	Clamping onto 5 or 6 mm thick copper bar, without drilling	10	<b>AK2-BA162U</b>	0.095
	4 to 25 mm <sup>2</sup> flexible cable or 6 to 35 mm <sup>2</sup> solid cable	10	<b>AB3-RV162U</b>	0.095



AB3-RV162U

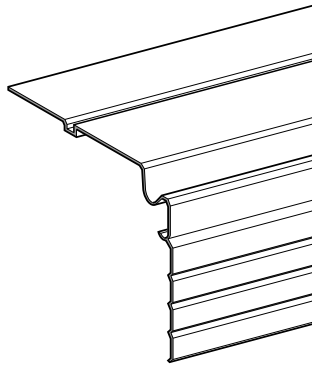

AK2-CB200

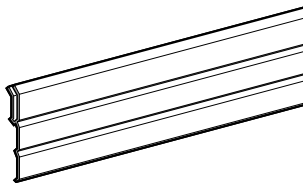

AK2-CP200

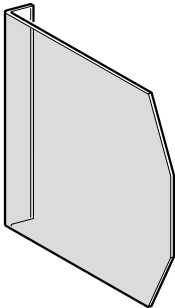

AK2-CE01

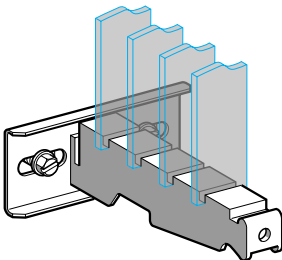

AK2-XB01



AK2-SC01

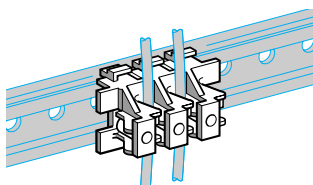

AK2-FC01

### Protective cover

Application	Fixing	Length mm	Sold in lots of	Unit reference	Weight kg
For 3 and 4-pole busbar systems	Clips onto AK2-SB busbar supports (1)	2000	1	<b>AK2-CB200</b>	0.960

### Cover extension

For 3 and 4-pole busbar systems	Clips or slides onto AK2-CB protective cover (2)	2000	1	<b>AK2-CP200</b>	0.210

### End partition

For insulating the ends of the busbar run from other metal components	Screw fixing with AF1-BA1 universal clamps on the busbar system insulated supports		1	<b>AK2-CE01</b>	0.085

### End stop

To keep the busbars in the vertical position	Screw fixing on the busbar system insulated supports		1	<b>AK2-XB01</b>	0.170

### Cable c.s.a. adapter

For clamping cables of varying c.s.a. (cables from 1 to 16 mm <sup>2</sup> with cables up to 95 mm <sup>2</sup> )	Used under AK2-SE terminal clamps		20	<b>AK2-SC01</b>	0.006

### Cable support

For cables from 10 to 95 mm <sup>2</sup> . Each cable is clamped between 2 cable supports. Example: 3 cables require 4 supports	Clips onto 25 and 35 mounting rails width: 35 mm then held by screw pressure		10	<b>AK2-FC01</b>	0.010

(1) Can be secured with M5 screw.

(2) Can be secured with ≤ M5 screw.

# Power distribution in control panels

Busbar systems: for horizontal and vertical power distribution

## Busbar system supports + protective covers

AK2-SB3● + AK2-CB●●● + AK2-CP●●●

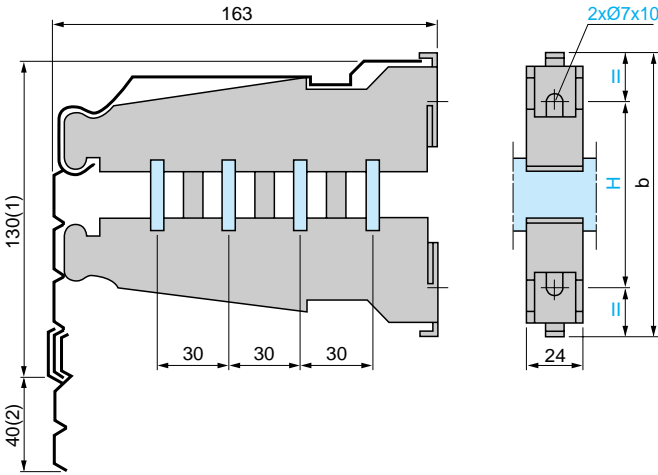

AK2-	bar size	b	H
SB31	12 x 5	98	57 ± 3
	20 x 5	106	65 ± 3
SB32	30 x 5	116	75 ± 3
	40 x 5	126	85 ± 3
SB33	50 x 5	136	95 ± 3
	60 x 5	146	105 ± 3

(1) Protective cover AK2-CB.

(2) Protective cover AK2-CP mounted on AK2-CB.

## Connector plates

AK2-SP20

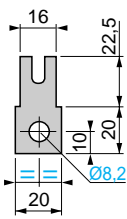

Thickness: 3 mm

AK2-SP30

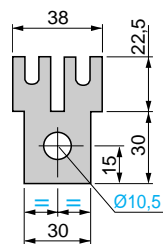

Thickness: 4 mm

AK2-SP40

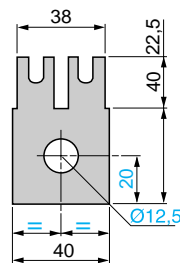

Thickness: 5 mm

## Associated screw clamp connector

AK2-BA01

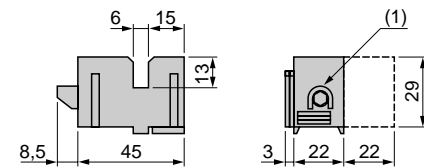

(1) CHc M6 screw.

## Terminal clamps

AK2-SE●●

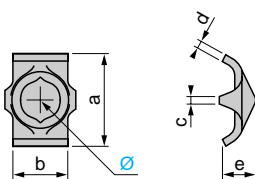

AK2-	a	b	c	d	e	Ø
SE20	20	13	5	2.5	8	8.8
SE25	25	15	6.5	3	9.5	10.8
SE30	30	15	6.5	3	11	10.8
SE40	40	19	9	3	12	12.8

## Single-pole splitter blocks

AK2-BA162U, AB3-RV162U

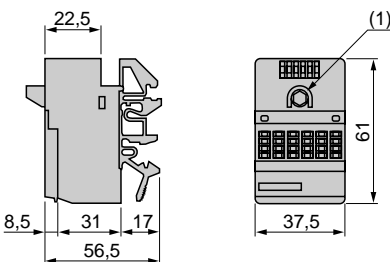

(1) CHc M6 screw.

## Mounting

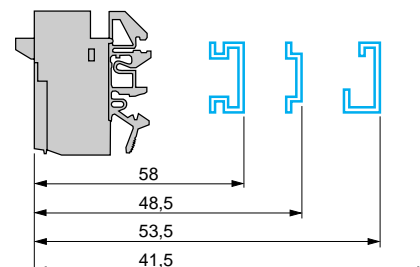

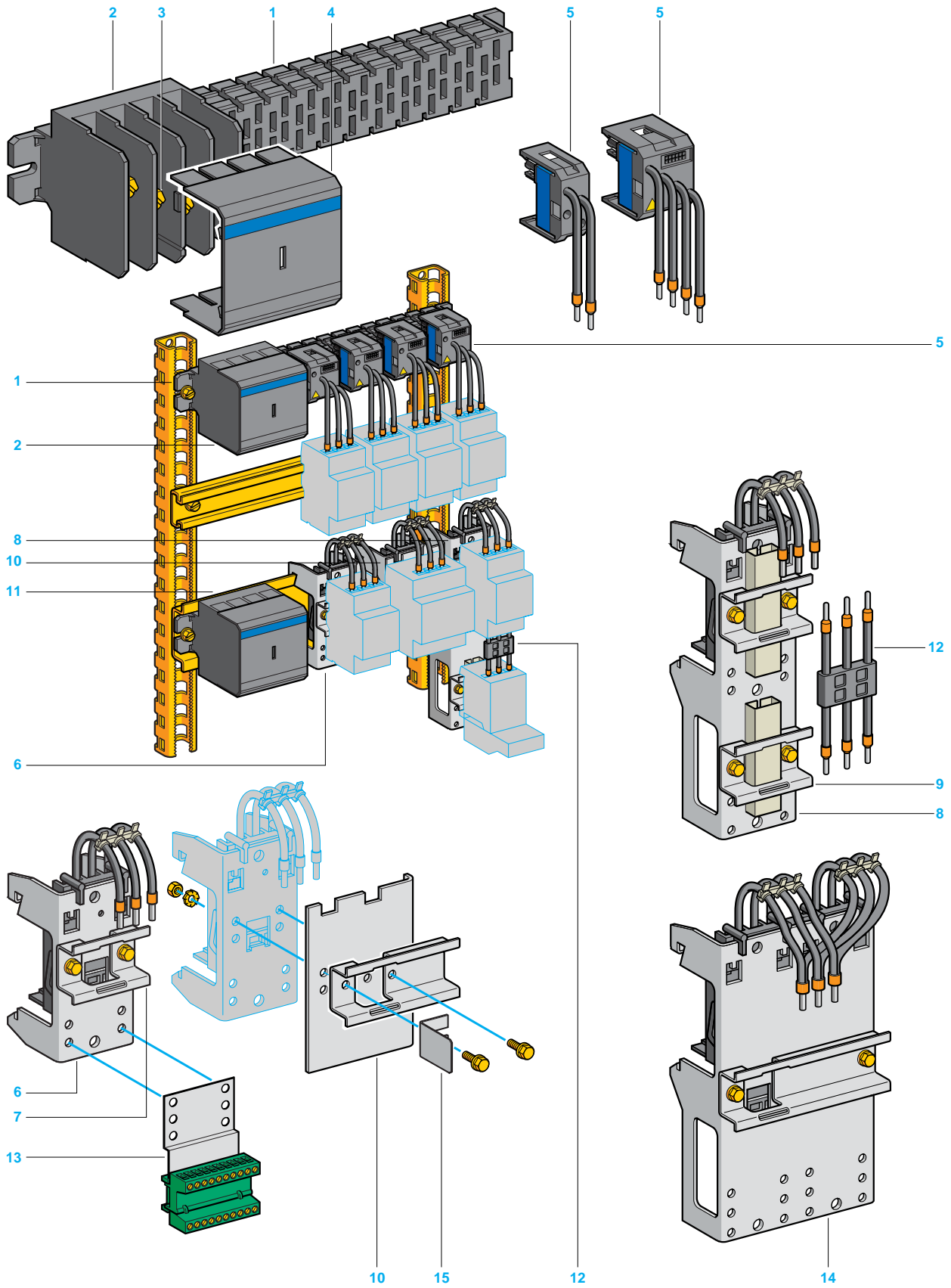



The assembly of automated control and distribution panels requires the use of products that are not only safe but also simple and quick to mount and cable.

The AK5 pre-assembled busbar system meets these criteria by incorporating prefabricated elements which cater for 3 principal functions:

### Carrying of electric current

Pre-assembled 4-pole busbar system **1**, 160 A at 35 °C.

4-pole busbar systems can be used for 3-phase + Neutral or 3-phase + Common.

The busbar systems are available in 6 lengths: 344, 452, 560, 668, 992, 1100 mm.

An incoming supply terminal block **2** is located at the extreme left of the busbar system.

“Knock-out” partitions allow connection of the power supply from above or below to the terminal block connections **3** which are protected by a removable cover **4**. Upstream protection of the busbar system is shown on page 13230/4.

### Current distribution

Tap-off units **5** (factory assembled) are available in 4 versions:

- 2-pole,
- 3-pole,
- 4-pole (3-phase + Neutral),
- 4-pole (3-phase + Common).

The tap-offs clip onto the busbar system with instantaneous mechanical and electrical connection to the busbars.

2 ratings are available: 16 and 32A.

The tap-off units ensure not only rapid mounting, but also a neat appearance for the power distribution system and complete safety when accessing under live circuit conditions.

### Component mounting

Component mounting plates with incorporated tap-off allow mounting of and supply of power to components. They are available in 25 A or 50 A ratings.

These mounting plates clip onto the mounting rail **11**, which also supports the busbar system, and at the same time make electrical connection via the incorporated tap-off.

2 types of mounting plate are available:

- single plate **6** (height 105 mm), with bolt-on 35 mm wide **7** rail **7**, which may be bolted on in one of two positions, allowing height adjustment of 10 mm.
- double plate **8** and **14** (height 190 mm), with two bolt-on, 35 mm wide **7** rails **9** mounted on 100 mm fixing centres; each rail may be bolted on in one of 4 positions, allowing height adjustment in 10 mm steps. These plates are supplied with connectors **12** to allow wiring between control and protection devices.

Single mounting plates enable the following types of distribution:

- 2-pole (Ph + N) and (Ph + Ph)
- 3-pole,
- 4-pole (3 Ph + N or 3 Ph + common).

Double mounting plates enable the following types of distribution; 2-pole (Ph + N, Ph + Ph), 3-pole or 4-pole (3 Ph + N and 3 Ph + common).

Extension plates **10** can be bolted onto single and double mounting plates to enable mounting of wider components. Using a side stop **15** in conjunction with these extension plates also supports the AK5 JB busbar system when used vertically.

A control terminal block **13** comprising a support plate bolted onto the single or double mounting plates and a 10-pole plug-in block, enables connection of the control circuit wires (c.s.a. 1.5 mm<sup>2</sup> max).

Busbar system characteristics								
Conforming to standards			IEC 60439					
Product certifications			UL, CSA, DNV, LROS					
Degree of protection	Against access to live parts		IP XXB conforming to IEC 60529					
Flame resistance	Conforming to IEC 60695	°C	850 (incandescent wire)					
	Conforming to UL 94		V0					
Number of conductors	AK5 JB14●		4					
Supply current			~					
Rated operational frequency		Hz	50 or 60					
Rated operational current	Ambient temperature 35 °C	A	160					
	Coefficient K to be applied according to the ambient temperature	°C	35	40	45	50	55	60
		K	1	0.96	0.92	0.88	0.83	0.78
Rated insulation voltage	Conforming to IEC 60439-1	V	690					
	Conforming to UL and CSA	V	600					
Operational voltage			Off-load plugging-in and unplugging, with supply switched on					
	Conforming to IEC 60439-1	V	400					
	Conforming to UL, CSA	V	480					
			Plugging-in and unplugging, with supply switched off					
	Conforming to IEC 60439-1	V	690					
	Conforming to UL, CSA	V	600					
Maximum permissible peak current		kA	25					
Maximum let-through energy		A <sup>2</sup> s	1 x 10 <sup>7</sup>					
Upstream short-circuit (1) and overload protection	Type of protection		Merlin Gerin circuit-breaker		Fuses			
			NS 160 H	NS 160 H	aM	gF		
	Rating	A	160	160	160	160		
	Prospective short-circuit current	kA	36	70	100	100		
	Operational current	A	160	160	160	160		
Connection			Maximum c.s.a.		Minimum c.s.a.			
	Flexible cable with cable end	mm <sup>2</sup>	70		2.5			
	Solid cable	mm <sup>2</sup>	70		2.5			
	Tightening torque	Nm	10					
Mounting position	Horizontal or vertical (2)		Fixing with screws provided					

(1) For conditions where conditional short-circuit current exceeds 25 kA.

(2) Using side stop **AK5 BT01** on mounting plates **AK5 PA**.

Tap-off characteristics											
Type		AK5 PC12	AK5 PC12PH	AK5 PC13	AK5 PC14	AK5 PC131	AK5 PC32L	AK5 PC32LPH	AK5 PC33 PC33L	AK5 PC34 PC34L	AK5 PC331
Conforming to standards		IEC 60439									
Product certifications		UL, LROS, CSA, DNV									
Degree of protection		Against access to live parts: IP XXB conforming to IEC 60529									
Polarity		Phase + Neutral	Phase + Phase	3-phase	3-phase + Neutral	3-phase + Common	Phase + Neutral	Phase + Phase	3-phase	3-phase + Neutral	3-phase + Common
Conductor c.s.a. (UL cables)	mm <sup>2</sup>	2 x 2.5	2 x 2.5	3 x 2.5	4 x 2.5	3 x 2.5 1 x 1.5	2 x 4	2 x 4	3 x 4	4 x 4	3 x 4 1 x 1.5
Conductor colours		Black Blue (Neutral)	Black	Black	Black Blue (Neutral)	Black White (Common)	Black Blue (Neutral)	Black	Black	Black Blue (Neutral)	Black White (Common)
Permissible current	A	16	16	16	16	16 10 (Common)	32	32	32	32	32 10 (Common)
Rated insulation voltage	V	690 conforming to IEC 60439-1									
Rated peak current	kA	6									
Maximum let-through energy	A <sup>2</sup> s	100 000					200 000				
Conductor insulation		PVC 105 °C									

Tap-off characteristics									
Type		AK5 PA211N1 PA211N2 PA211N3 PA212N1 PA212N2 PA212N3	AK5 PA211PH12 PA211PH13 PA211PH23 PA212PH12 PA212PH13 PA212PH23	AK5 PA231 PA232 PA232S	AK5 PA241 PA242	AK5 PA2311 PA2312 PA2312S	AK5 PA532	AK5 PA542	AK5 PA5312
Conforming to standards		IEC 60439							
Product certifications		UL, LROS, CSA, DNV							
Degree of protection		Against access to live parts: IP XXB conforming to IEC 60529							
Polarity		Ph + N	Ph + Ph	3-phase	3-phase + Neutral	3-phase + Common	3-phase	3-phase + Neutral	3-phase + Common
Conductor c.s.a. (UL cables)	mm <sup>2</sup>	2 x 4	2 x 4	3 x 4	4 x 4	3 x 4 1 x 1.5	2 x (3 x 4)	2 x (4 x 4)	2 x (3 x 4) 1 x 1.5
Permissible current	A	25	25	25	25	25 10 (Common)	50	50	50 10 (Common)
Rated insulation voltage	V	690 conforming to IEC 60439-1							
Rated peak current	kA	6							
Maximum let-through energy	A <sup>2</sup> s	200 000							
Conductor insulation		PVC 105 °C							

### Characteristics of mounting rails AM1 DL201 and AM1 DL2017

Type	Omega  (width 75 mm, depth 15 mm)
Material	2 mm sheet steel
Surface treatment	Zinc

Component mounting plates incorporating tap-off mounted on AK5 JB busbar system

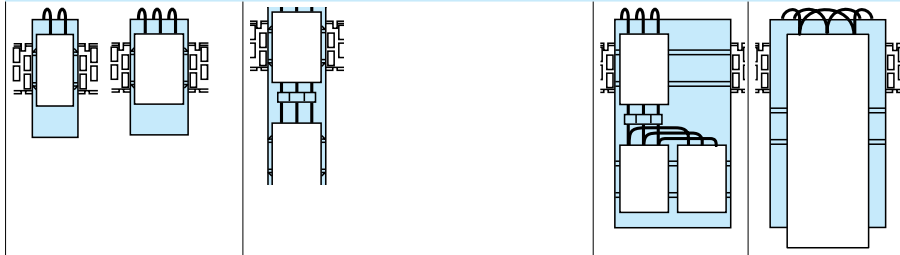

**Note:** if the equipment is wider than the mounting plate, an extension plate can be used to increase the width of the support plate.

(1) 3-pole + common

	AK5 PA211N1 PA211N2 PA211N3	AK5 PA231 PA2311 (1)	AK5 PA241	AK5 PA212N1 PA212N2 PA212N3	AK5 PA212PH12 PA213PH13 PA212PH23	AK5 PA232 PA2312 (1)	AK5 PA242	AK5 PA232S PA2312S (1)	AK5 PA532 PA5312 (1)	AK5 PA542
<b>Mounting plate</b> Width in mm	54	54	54	54	54	54	54	108	108	108
<b>incorporating tap-off</b> Height in mm	105	105	105	190	190	190	190	190	190	190
No. of 18 mm pitches	3	3	3	3	3	3	4	6	6	6
Thermal current	25 A	25 A	25 A	25 A	25 A	25 A	25 A	25 A	50 A	50 A
Application	Ph + N	3-Ph	3-Ph + N	Ph + N	Ph + Ph	3-Ph	3-Ph + N	3-Ph	3-Ph	3-Ph + N

Type of starter	Minimum centres with 60 mm ducting	Number of points used on the busbar system

**Fuses, contactors and thermal overload relay**

LS1 D25	170	4	4	–	–	–	–
LS1 D25 + LA8 D254	170	–	–	5	–	–	–
LS1 D25 + LC1 D09 to D25 and overload relay up to LR2 D1322	320	–	–	–	4	–	–
LS1 D25 + LC1 D09 to D25 (with 1 add-on block LA8 D) + overload relay up to LR2 D1322	320	–	–	–	4	–	–

**Fuses, reversing contactors + thermal overload relay**

LS1 D25 + LC2 D09 to D18 (with 1 add-on block LA8 D) + overload relay up to LR2 D1322	320	–	–	–	–	6	–
LS1 D25 + LC2 D25 (with 1 add-on block LA8 D) + overload relay up to LR2 D1322	320	–	–	–	–	7	–

**Optimal breaker switch**

GK2 CF03 to 22	170	–	3	–	–	–	–
GK2 CF03 to 22 + 4 blocks GK2 AX	170	–	5	–	–	–	–
GK3 EF40	270	–	–	–	–	–	6
GK3 EF40 + 4 blocks GK2 AX	270	–	–	–	–	–	6

**Optimal breaker switch + contactor + thermal overload relay**

GK2 CF03 to CF21 + LC1 D09 to D18 + overload relay up to LR2 D1322	320	–	–	–	3	–	–
GK2 CF03 to CF22 + LC1 D09 to D25 + overload relay up to LR2 D1322	320	–	–	–	4	–	–
GK2 CF03 to CF22 + 4 blocks GK2 AX + LC1 D09 to D18 with 1 block LA8 D + overload relay up to LR2 D1322	320	–	–	–	5	–	–

**Optimal breaker switch + reversing contactor + thermal overload relay**

GK2 CF03 to CF22 + 4 blocs GK2 AX + LC2 D09 to D18 with 1 block LA8 D + overload relay up to LR2 D1322	320	–	–	–	–	6	–
GK2 CF03 to CF22 + 4 blocks GK2 AX + LC2 D25 with 1 block LA8 D + overload relay up to LR2 D1322	320	–	–	–	–	7	–

Component mounting plates incorporating tap-off mounted on AK5 JB busbar system



**Note 1:** if the equipment is wider than the mounting plate, an extension plate can be used to increase the width of the support plate.

**Note 2:** for upstream protection, see page 13230/4.

(1) 3-pole + common

Mounting plate incorporating tap-off	AK5 PA211N1 PA211N2 PA211N3	AK5 PA231 PA2311 (1)	AK5 PA241	AK5 PA212N1 PA212N2 PA212N3	AK5 PA212PH12 PA213PH13 PA212PH23	AK5 PA232 PA2312 (1)	AK5 PA242	AK5 PA232S PA2312S (1)	AK5 PA532 PA5312 (1)	AK5 PA542
Width in mm	54	54	54	54	54	54	54	108	108	108
Height in mm	105	105	105	190	190	190	190	190	190	190
No. of 18 mm pitches	3	3	3	3	3	3	4	6	6	6
Thermal current	25 A	25 A	25 A	25 A	25 A	25 A	25 A	25 A	50 A	50 A
Application	Ph + N	3 Ph	3 Ph + N	Ph + N	Ph + Ph	3 Ph	3 Ph + N	3 Ph	3 Ph	3 Ph + N

Type of starter	Minimum centres with 60 mm ducting	Number of points used on the busbar system
<b>Motor circuit-breaker (type 1 coordination)</b>		

GV2 ●06 to ●22	170	–	3	–	–	–	–	–	–
GV3 M01 to M40	270	–	–	–	–	–	–	–	6

Circuit-breaker + contactor									
GV2 ●06 to ●16 + LC1 D09 or D12 with 1 add-on block LA8 D	270	–	–	–	4	–	–	–	–
GV2 ●06 to ●20 + LC1 D09 to D18	270	–	–	–	3	–	–	–	–
GV2 ●06 to ●22 + LC1 D09 to D25 with 1 add-on block LA8 D	270	–	–	–	4	–	–	–	–
GV3 M01 to M40 with GV1 A●● + LC1 D09 to D32	270	–	–	–	–	–	–	–	7
GV3 M01 to M40 + LC1 D09 to D32 with 1 add-on block LA8 D	270	–	–	–	–	–	–	–	8

Motor circuit-breaker + reversing contactor									
GV2 ●06 to ●20 + LC2 D09 to D18 with or without add-on block LA8 D	270	–	–	–	–	–	6	–	–
GV2 ●22 + LC2 D25 with 1 add-on block LA8 D	270	–	–	–	–	–	7	–	–

Integral contactor breaker + protection module									
LD1 LB030 + LB1 LB03P●● (integral 18)	270	–	3	–	–	–	–	–	–
LD1 LB030 with 2 add-on blocks LA1 LB + LB1 LB30P (integral 18)	270	–	4	–	–	–	–	–	–
LD1 LB030 with 4 add-on blocks LA1 LB + LB1 LB03P (integral 18)	270	–	–	–	–	–	6	–	–
LD1 LC030 + LB1 LC03M (integral 32)	270	–	–	–	–	–	–	–	6
LD1 LC030 + LB1 LC03M (integral 32) with 1 add-on block LA1 LC and 1 reset device LA1 LC052●	270	–	–	–	–	–	–	–	7
LD1 LC030 with 2 add-on blocks LA1 LB + LB1 LC03M (integral 32)	270	–	–	–	–	–	–	–	6

Reversing contactor breaker integral 18 + protection module									
LD5 LB130 + LB1 LB03P●●	270	–	–	–	–	–	6	–	–
LD5 LB130 with 3 add-on blocks LA1 LB + LB1 LB03P	270	–	–	–	–	–	8	–	–

Merlin Gerin C 60 circuit-breaker for circuit protection									
2369●	170	2	–	–	2	–	–	–	–
2370●	170	–	3	–	–	3	–	3	–
2371● and 2372●	170	–	–	4	–	–	4	–	4

# Power distribution in control panels

## Pre-assembled panel busbar system AK5

### Busbar systems, tap-off units

Catalogos en azul de entrega inmediata en planta

#### Busbar systems

The busbar system can be screw-mounted onto any type of support. However, if it is to be used in conjunction with component mounting plates incorporating a tap-off, it is essential that it is mounted on the AM1 DL201 rail. When mounting tap-offs, the rated operational current of the busbar system should be taken into account: 160 A at 35 °C.

Number of conductors	Number of tap-offs at 18 mm intervals	Length mm	Suitable for mounting in enclosure width mm	Reference	Weight kg
4 (1)	12	344	600	AK5 JB143	0.700
	18	452	800	AK5 JB144	0.900
	24	560	800	AK5 JB145	1.100
	30	668	800	AK5 JB146	1.300
	48	992	1200	AK5 JB149	1.900
	54	1100	1200	AK5 JB1410	2.100

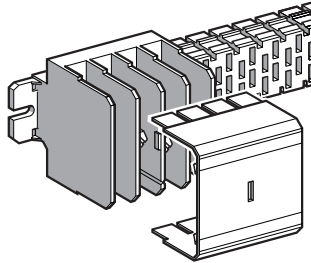

AK5 JB1●●

#### Omega rail, width 75 mm

This rail is designed to accommodate the busbar system when it is used with AK5 PA mounting plates incorporating tap-offs. It supports the busbar system. The plates simply clip onto the rail.

Material and surface treatment	Depth mm	Length mm	Sold in lots of	Unit reference	Weight kg
2 mm sheet steel treated with zinc	15	2000 (4)	6	AM1 DL201	3.000

#### Removable power sockets

Use	Number of points used on the busbar system	Thermal current A	Cable length mm	Sold in lots of	Unit reference	Weight kg
Single-phase + Neutral	1	16	200	6 (2)	AK5 PC12	0.035
		32	1000	6 (2)	AK5 PC32L	0.040
2-phase	1	16	200	6 (3)	AK5 PC12PH	0.035
		32	1000	6 (3)	AK5 PC32LPH	0.040
3-phase	2	16	200	6	AK5 PC13	0.040
		32	250	6	AK5 PC33	0.045
		1000	1000	6	AK5 PC33L	0.060
3-phase + Neutral	2	16	200	6	AK5 PC14	0.045
		32	250	6	AK5 PC34	0.050
3-phase + common	2	16	200	6	AK5 PC131	0.045
		10 (common)	250	6	AK5 PC331	0.050
		32	250	6	AK5 PC331	0.050
		10 (common)				

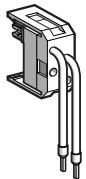

AK5 PC12

AK5 PC14

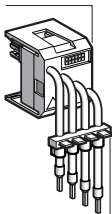

AK5 GF1

#### Accessories

Description	Maximum no. of connections	C.s.a. mm <sup>2</sup>	Sold in lots of	Unit reference	Weight kg
Cable guide	4	2.5 or 4	20	AK5 GF1	0.300

(1) 4-pole: 3-phase + Neutral or 3-phase + Common.

(2) Total of 6 sockets supplied: 2 sockets (N + L1), 2 sockets (N + L2), 2 sockets (N + L3).

(3) Total of 6 sockets supplied: 2 sockets (L1 + L2), 2 sockets (L1 + L3), 2 sockets (L2 + L3).

(4) Cut and drill to suit use.

# Power distribution in control panels

## Pre-assembled panel busbar system AK5

Component mounting plates, extension plates, terminal blocks, mounting rails, accessories

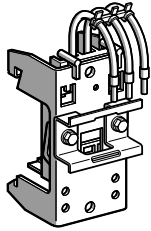

AK5 PA231

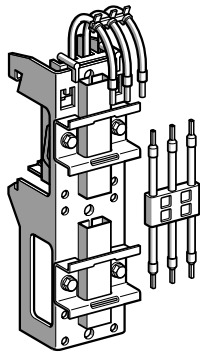

AK5 PA232

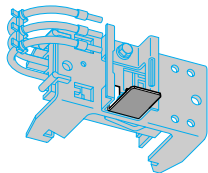

AK5 BT01

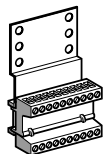

AK5 SB1

### Component mounting plates incorporating tap-off

Use	No. of 18 mm points used on the busbar system	Phase	Thermal current	Number of L rails for component support	Reference	Weight
<b>Single plate (height 105 mm)</b>						
Single-phase + neutral	3	Ph1+N	25	1	AK5 PA211N1	0.135
		Ph2+N	25	1	AK5 PA211N2	0.135
		Ph3+N	25	1	AK5 PA211N3	0.135
2-phase	3	Ph1+Ph2	25	1	AK5 PA211PH12	0.135
		Ph1+Ph3	25	1	AK5 PA211PH13	0.135
		Ph2+Ph3	25	1	AK5 PA211PH23	0.135
3-phase	3	–	25	1	AK5 PA231	0.140
3-phase + common	3	–	25	1	AK5 PA2311	0.145
3-phase + neutral	3	–	25	1	AK5 PA241	0.145

### Double plate (height 190 mm)

Prefabricated 25 A connectors are supplied for connecting the 2 protection and control devices.

Use	No. of 18 mm points used on the busbar system	Phase	Thermal current	Number of L rails for component support	Reference	Weight
Single-phase + neutral	3	Ph1+N	25	2	AK5 PA212N1	0.135
		Ph2+N	25	2	AK5 PA212N2	0.135
		Ph3+N	25	2	AK5 PA212N3	0.135
2-phase	3	Ph1+Ph2	25	2	AK5 PA212PH12	0.135
		Ph1+Ph3	25	2	AK5 PA212PH13	0.135
		Ph2+Ph3	25	2	AK5 PA212PH23	0.135
3-phase	3	–	25	2	AK5 PA232	0.230
		–	25	2	AK5 PA232S	0.600
		–	50	1	AK5 PA532	0.700
3-phase + neutral	3	–	25	2	AK5 PA242	0.230
3-phase + common	3	–	25 (10 common)	2	AK5 PA2312	0.235
		–	25 (10 common)	2	AK5 PA2312S	0.610
		–	50 (10 common)	1	AK5 PA5312	0.710
3-phase + neutral	6	–	50	1	AK5 PA542	0.715

### Extension plates

These plates bolt onto the support plates, after having removed them from the rails, to be able to mount wider components.

Use		Number of tap-offs at 18 mm intervals	Reference	Weight kg
For mounting plates incorporating tap-off	Single	4	AK5 PE17	0.100
	Double	4	AK5 PE27	0.150

### Side stop (AK5-JB mounted vertically)

Use	Sold in lots of	Unit reference	Weight kg
For extension plate	50	AK5 BT01	0.005

### Control terminal blocks

Description	Thermal current A	Sold in lots of	Unit reference	Weight kg
	A			kg
<b>10-pole terminal blocks, for screwing onto plate AK5 PA●●●</b>				
	10	10	AK5 SB1	0.065
<b>10-pole front connecting plug-in terminal blocks which can be clipped onto 25 L rails</b>				
Fixed part	10	10	AB1 DV10235U	0.047
Moving part	10	10	AB1 DVM10235U	0.021

### Accessories

Description	Marking	Sold in lots of	Unit reference	Weight kg
Strips of clip-in markers 10 identical numbers, signs or capital letters per strip	0...9	25	AB1 R● (1)	0.050
	+	25	AB1 R12	0.050
	–	25	AB1 R13	0.050
	A...Z	25	AB1 G● (1)	0.050

(1) Replace the ● in the selected reference with the number or letter required. Example: AB1 R1 or AB1 GA.

### Busbar systems

#### AK5 JB●●●

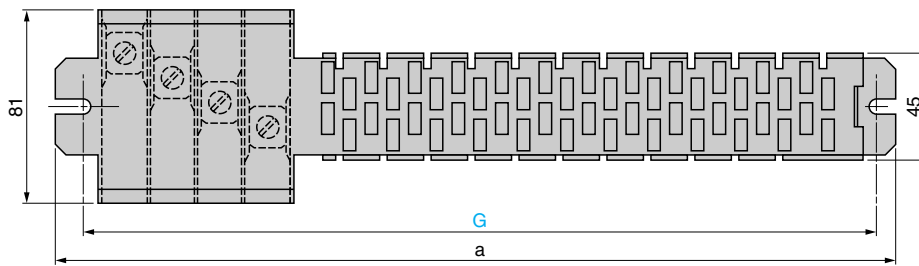
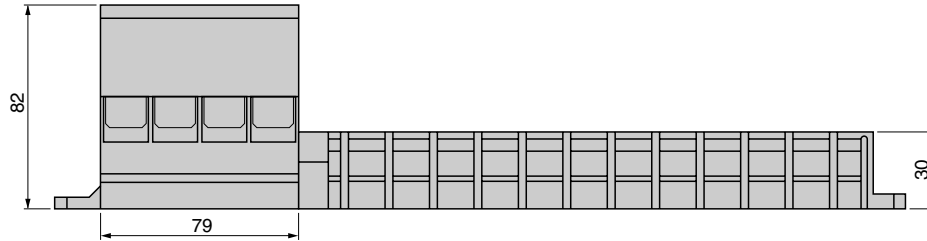

AK5	a	G	N° of 18 mm points
JB143	344	330	12
JB144	452	438	18
JB145	560	546	24
JB146	668	654	30
JB149	992	978	48
JB1410	1100	1086	54

### Busbar feed units

#### AK5 JB●●●

#### Installation of AK5 JB●●● busbar systems

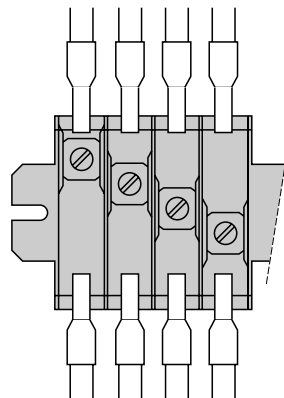

Connection	C.s.a. in mm <sup>2</sup>	
	min.	max.
Flexible cable with or without cable end		
	1 x 2.5	1 x 70 (1)
	2 x 2.5	2 x 35
Flexible bar		
	-	2 x (9 x 4)
Flexible bar		
	9 x 4	9 x 4
+	+	+
flexible cable with or without cable end	1 x 2.5	1 x 35

(1) Maximum c.s.a. or connection of conductor without cable end.

#### Removable power sockets, 16 and 32 A

##### AK5 PC12●, AK5 PC32L●

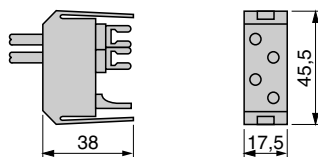

##### AK5 PC●3, AK5 PC33L AK5 PC●4, AK5 PC34L AK5 PC●31

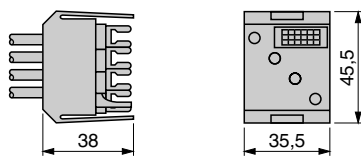

#### Mounting plates incorporating tap-offs, 25 A

##### AK5 PA2●1, AK5 PA2311, AK5 PA211●●●

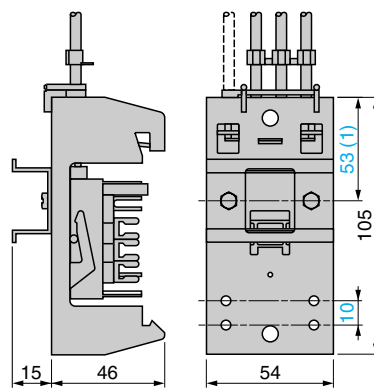

#### Single width extension plates

##### AK5 PE17

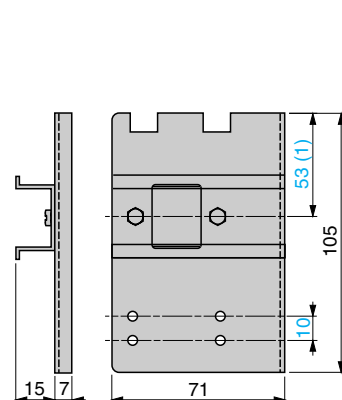

**Note :** It is recommended that the power sockets or the removable plates are connected as close as possible to the busbar feed unit.

(1) Can be fixed at 43 mm



**Mounting plates incorporating tap-off**  
AK5 PA232, AK5 PA2312, AK5 PA242

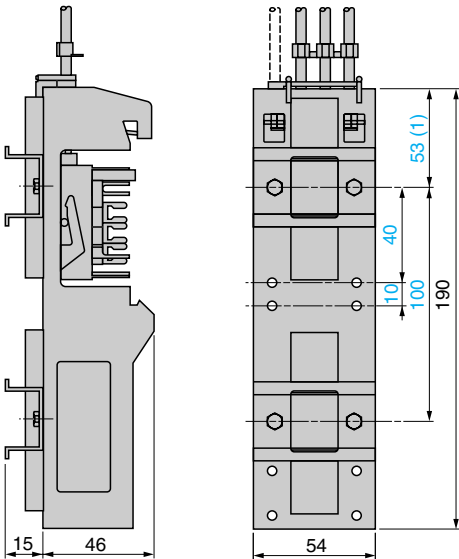

**Double width extension plate**  
AK5 PE27

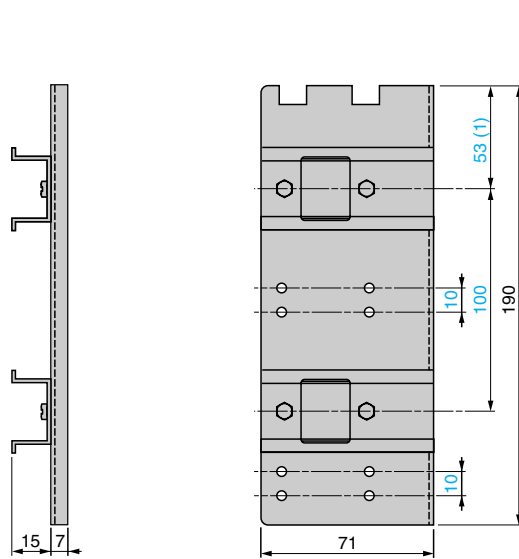

**Mounting plates incorporating tap-off**  
AK5 PA232S, AK5 PA2312S

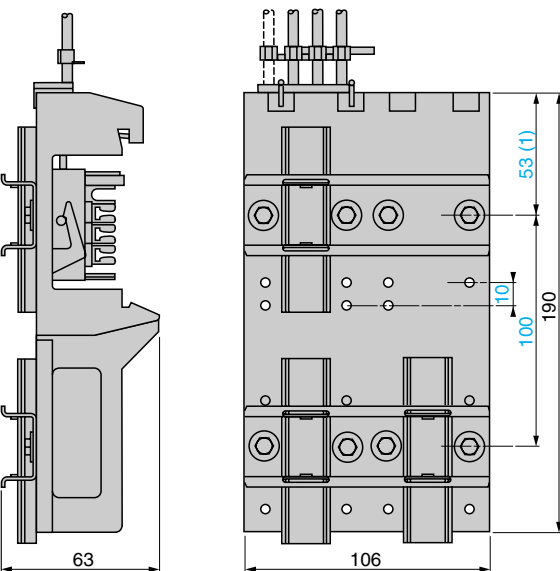

AK5 PA532, AK5 PA5312, AK5 PA542

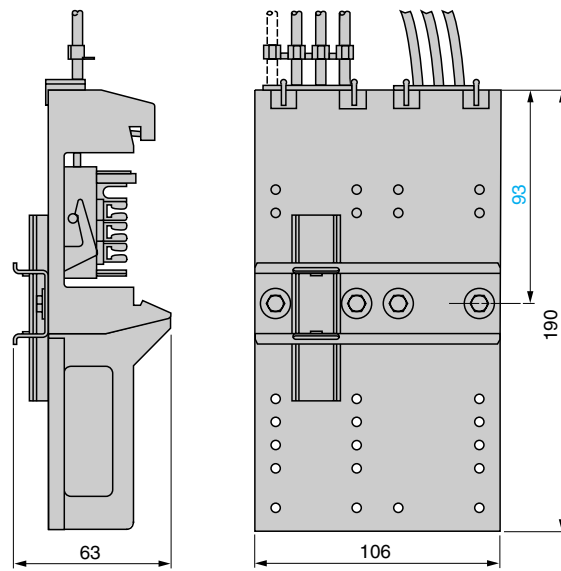

**Side stop**  
AK5 BT01

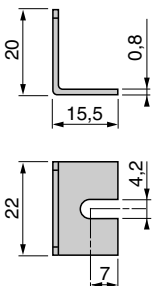

**Control terminal block**  
AK5 SB1

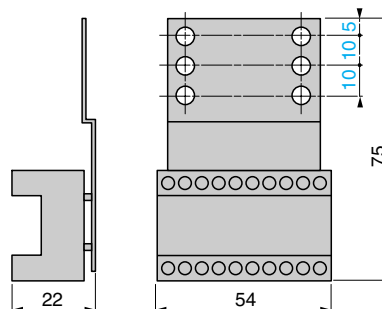

(1) Can be fixed at 43 mm

# Power distribution in control panels

## CMD® prefabricated plug-in busbar trunking

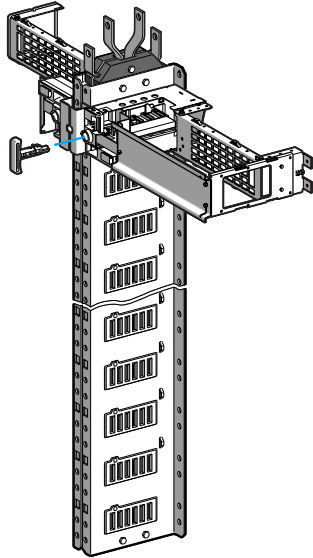

The design and manufacture of automation and distribution systems often requires the use of a busbar system to carry current and supply power to several individual tap-off outlets.

The Telemecanique CMD® prefabricated busbar system enables panel builders to minimise mounting and wiring time for both open type and enclosed equipment. Only 4 fixing points are needed to install the prefabricated busbar system, which fits easily into all standard 2 metre high enclosures. The self-supporting busbar can provide mechanical support for up to 32 tap-offs.

The CMD® busbar system provides 4 main functions:

### carrying of electric current

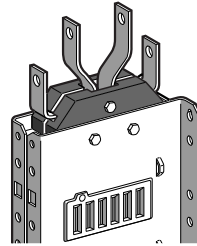

By means of 3 or 4-pole busbar systems.  
2 ratings are available: 400 and 800 A.  
The factory assembled busbar system is fully protected by a metal casing.

### distribution of electric current

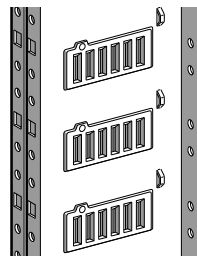

The busbar system has 32 tap-off outlets, 16 on each side, on 100 mm centres. Each tap-off outlet hooks easily onto the front of the busbar system.

The tap-off system is fast and safe.  
Electrical connection is made automatically by means of stab connectors, operated from the front by means of a removable key.

### isolation of individual tap-offs

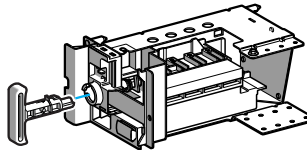

Each tap-off outlet can be isolated by means of a visible break disconnect block, without having to switch off the mains supply, thus allowing continuous operation.

The break is visible and there is a padlocking facility for up to 3 padlocks in the isolate position.

### support of the equipment

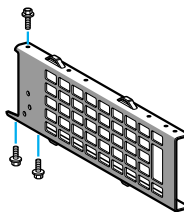



Mounting plates (1, 2 or 3 100 mm modules) are simply and automatically positioned on the support block by means of 3 screws.  
Their depth is adjustable.  
Each plate is pre-drilled to allow easy fixing of contactor breakers.  
Telequick type slots are provided for all other products which can be clipped on from the front.

Further accessories allow panels to be adapted to suit specific applications and operating requirements:

- mechanical interlocking device to prevent on-load disconnection.
- early break auxiliary contact block.
- partitioning components, enabling physical separation of the tap-off outlets.
- mounting rail supports, for rail mounting of terminal blocks.
- end fixing bracket (for use on panels subject to vibration),
- front plate (can be used to mount control and signalling units).
- special protective conductor.

# Power distribution in control panels

## CMD® prefabricated plug-in busbar trunking

Characteristics	
Conforming to standards	Components for building low voltage equipment conforming to standards NF EN 60439.1, (C63-421), NF C 63412, IEC 439-1. Visible break disconnect block: utilization category AC 20 conforming to IEC 947-3.
Product certifications	CMD 400 A : BV, DNV, GL, OVE, LROS, NKK, CSA,  RINA. CMD 800 A : OVE, LROS, NKK, CSA,  RINA. <b>IMPORTANT:</b> If the CMD busbar system is used for building UL equipment: <b>The system builder must:</b> - <b>install</b> an overvoltage protection device recognised by UL, upstream of the installation, example: <b>Square D</b> reference <b>SP3650</b> . - <b>carry out assembly to AK3-LK1</b> (drawing file) in installations where incoming power supply is by means of cables with $I_{sc} > 35$ kA, - <b>provide all necessary markings</b> (tightening torque, temperature class of conductors, short-circuit current, etc..).
Protective treatment	"TC".
Degree of protection Conforming to IEC 529	Busbar tap-off outlets: IP 40. Bare disconnect block: IP XXB (against access to live parts).
Resistance to external mechanical impact	2 joules. Code IK 07 conforming to NF EN 50102.
Mounting method	Busbars: - from the front by 4 Ø 10 holes, one of which is a button-hole type to facilitate positioning. Tap-off outlet: - positioning from the front by 4 locating pins, - manual locking by applying pressure, - unlocking by 1/4 turn using a screwdriver.
Material	Metal casing for busbars: 1.5 mm galvanised sheet steel Disconnect block support: 1.5 mm galvanised sheet steel Equipment mounting plate: 2 mm galvanised sheet steel.
Busbars	3-pole or 4-pole: 33 x 8 silver plated copper (400 A) 66 x 8 silver plated copper (800 A)
Rated insulation voltage	690 V conforming to IEC 439.1
Rated current	Busbars: 400 A and 800 A (see table below). Disconnect block: 125 A and 250 A.
Short-circuit current withstand	Nominal short time rating (1 s): 50 kA rms. Nominal peak current: 105 kA (cos φ: 0.25).
Earthing	Earthing continuity between the busbars and the tap-off modules by a copper pressure contact mounted on the disconnect block support.
Protective conductor	Provided by the busbar metal casing (copper equivalent c.s.a.: 70 mm <sup>2</sup> , resistance 0.248 mΩ/m). As an option: special 25 x 2 mm copper conductor (total copper equivalent c.s.a.: 120 mm <sup>2</sup> , resistance 0.155 mΩ/m).
Disconnect block cable capacity	2.5 to 16 mm <sup>2</sup> cable with cable end (using clamp). 50 mm <sup>2</sup> cable with lug (using M6 screw).

**Permissible peak current**  
in a horizontally mounted busbar system, depending on distance between insulated support blocks.

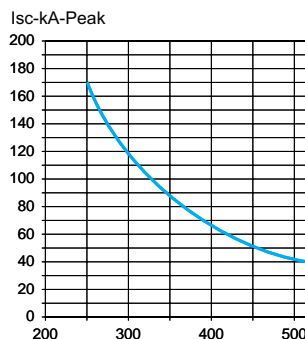

Ambient temperature 35 °C			
	Derating factors	Rated current (A)	
		CMD 400	CMD 800
In enclosure	0.75	400	–
	0.8	–	800
In open air	1	300	630
	1	400	800

1 or 2 busbars  
50 x 5/Ph or  
50 x 10/Ph  
Fixing centres between insulated support blocks in mm

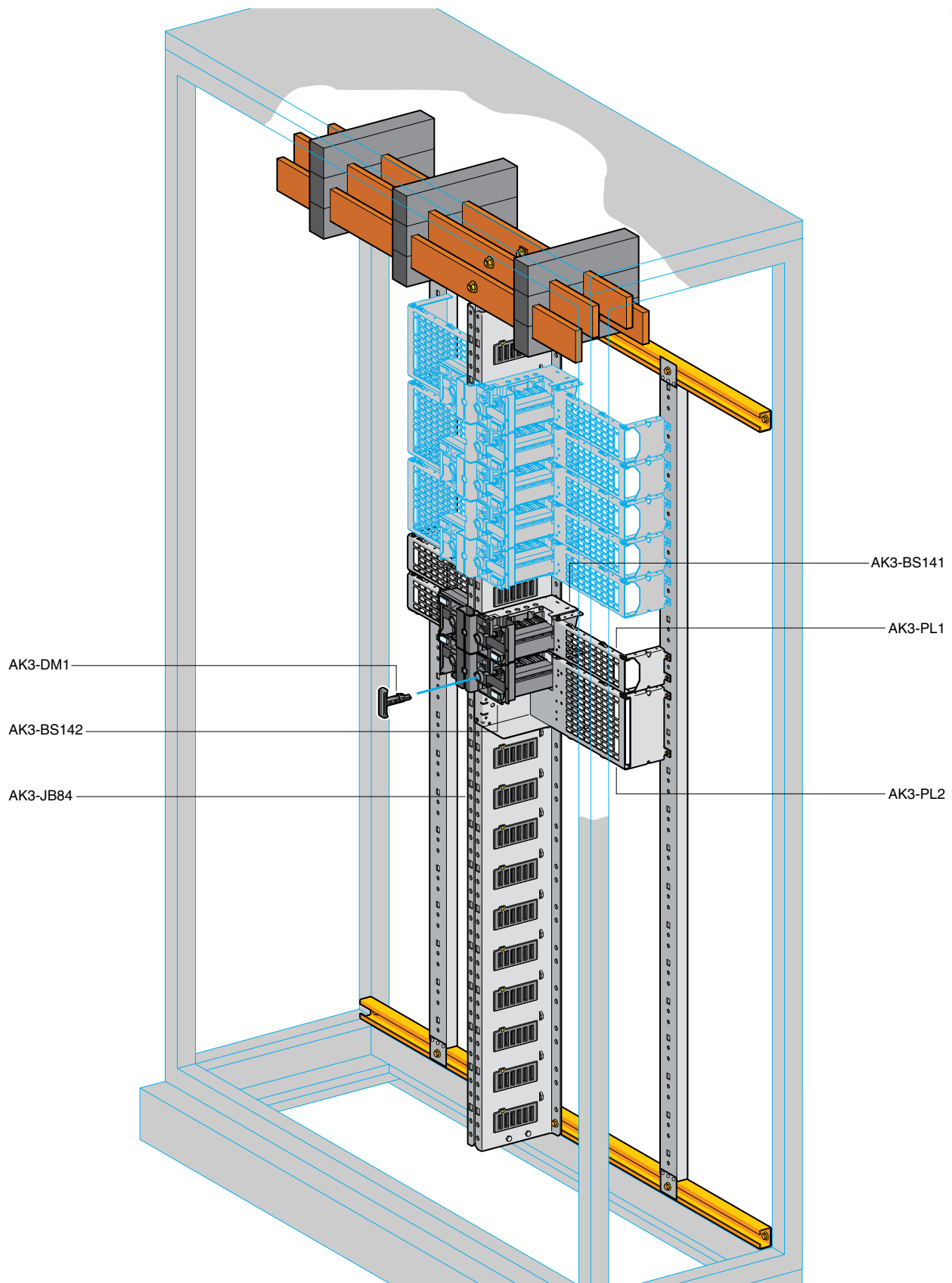

# Power distribution in control panels

## CMD® prefabricated plug-in busbar trunking

### Vertical or horizontal distribution system

#### Busbar system with metal casing (1)

Rating	Number of tap-off outlets (100 mm pitch)	Polarity	Reference	Weight kg
400 A	32 (16 on each side)	3-pole	AK3-JB43	25.000
		3-pole + N	AK3-JB44	30.000
800 A	32 (16 on each side)	3-pole	AK3-JB83	40.000
		3-pole + N	AK3-JB84	50.000

#### Disconnect blocks (2)

Supplied fitted with AK3-SB● supports for mounting AK3-PL● pre-slotted plates

Rated thermal current	Polarity	Number of 100 mm modules	Reference (4)	Weight kg
125 A	3-pole + N + PE	1	AK3-BS141	1.500
		2	AK3-BS142	2.000
		3	AK3-BS143	2.500
250 A (3)	3-pole + N + PE	2	AK3-BS242	3.000
		3	AK3-BS243	3.500

#### Slotted mounting plates

Supplied with screws for fixing onto AK3-SB● supports (included with AK3-BS●●● disconnect block or for use without disconnect block - see page 13221/4). This corresponds to one tap-off outlet module.

Application	Suitable for fixing on	Number of 100 mm modules	Reference	Weight kg
For mounting equipment	AK3-BS141 or AK3-SB1	1	AK3-PL1	0.350
	AK3-BS142 or AK3-SB2	2	AK3-PL2	0.800
	AK3-BS242	2	AK3-PL2M	0.680
	AK3-BS●43 or AK3-SB3	3	AK3-PL3	1.250

#### Operating key

Application	Sold in lots of	Unit reference	Weight kg
Ensures operation of the disconnect block stab connectors (key can only be withdrawn in position "O" or "I")	5	AK3-DM1	0.028

(1) The protective conductor PE is normally provided by the metal busbar casing.

(2) Visible break isolation.

Padlocking facility for up to 3 padlocks in the disconnected position.

A test device incorporated in the disconnect blocks allows testing of the control circuit in the isolated position (when early break auxiliary contact block(s) have been fitted).

(3) The 250 A disconnect blocks are made up using two 125 A disconnect blocks, mechanically interlocked with a single operator.

(4) Marine specification: 'Marine' specification as standard. It is essential to use extra lateral support for the mounting plate (see page 13221/5).

# Power distribution in control panels

## CMD® prefabricated plug-in busbar trunking

Accessories for assembly by the user (to be ordered separately)

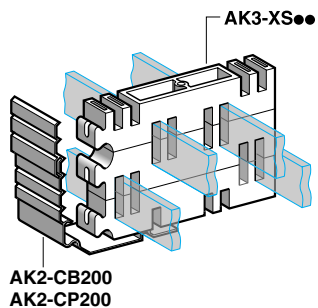
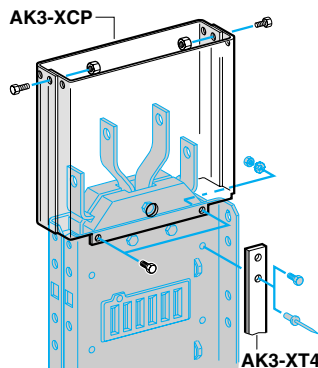
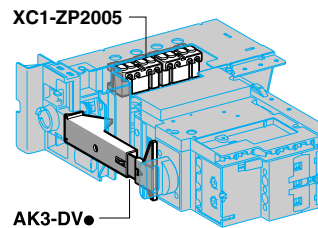
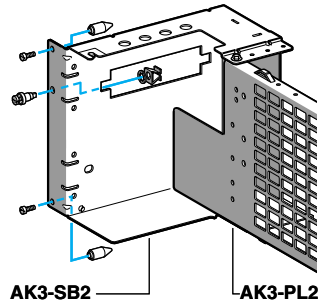

### Mounting plate supports (1) without disconnect block

Application	Number of 100 mm modules	Reference	Weight kg
For mounting pre-slotted plate AK3-PL with depth adjustment. Supplied with necessary accessories for fitting onto the busbar system.	1	AK3-SB1	0.700
	2	AK3-SB2	1.200
	3	AK3-SB3	1.700

### Mechanical interlock device (2)

Application	Can be used with	Reference	Weight kg
Prevents on-load disconnection when associated with - an integral 18, 32 or 63 contactor breaker or - a GV3 motor circuit breaker	Integral 18, 32, GV3	AK3-DV1	0.080
	Integral 63	AK3-DV2	0.180

### Auxiliary contact

<ul style="list-style-type: none"> <li>For early breaking of the control circuit and ensuring off-load disconnection (1 or 2 contacts may be fitted)</li> <li>For signalling either the "On" or the "Off" state of the disconnect block (1 contact only may be fitted)</li> </ul>	XC1-ZP2005	0.040
---	------------	-------

### Protective cover for busbar head

Description	Application	Reference	Weight kg
Cover consisting of 2 identical parts; the distance between these parts can be adjusted according to the busbar rating.	CMD 400 A, CMD 800 A	AK3-XCP	0.630

### Special protective earth conductor

25 x 2 mm copper bar with rounded edges for fixing by rivets or nuts and bolts at the appropriate positions along the busbar run	AK3-XT4	0.730
--	---------	-------

### Insulated busbar support blocks (3)

Description Application	Permissible current (4) A	Number and c.s.a. of copper bars per phase mm	Sub-assembly reference	Weight kg
Sub-assembly comprising 3 identical insulated busbar support blocks and fixing screws for the assembly of a horizontal busbar system by the user (busbars not supplied).	600	1 x 50 x 5	AK3-XS05	1.600
	880	1 x 50 x 10	AK3-XS10	1.450
	1080	2 x 50 x 5	AK3-XS05	1.600
	1580	2 x 50 x 10	AK3-XS10	1.450

(1) The mounting plate support can accommodate the AK3-CF2C additional front plate (see page 13221/7).

(2) This device does not exist for either GV2 or integral LD4: for these products, use a contact block reference XC1-ZP2005.

(3) These are compatible with AK2-CB200 and CP200 protective covers (see page 13211/4), clip-on fixing or clip-on + Ø 6 screw (not supplied).

(4) Permissible peak current according to distance between the insulated support blocks.

# Power distribution in control panels

## CMD® prefabricated plug-in busbar trunking

### Accessories (to be ordered separately)

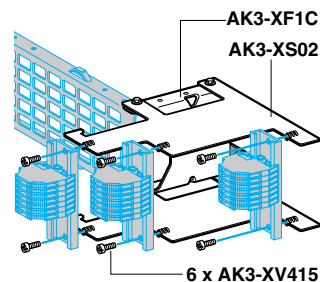
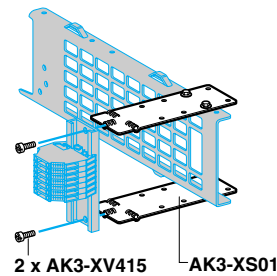
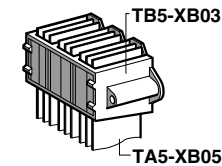
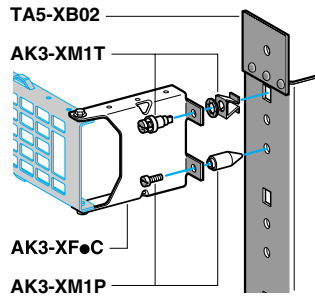

#### For extra lateral support of mounting plate (1)

Description	Sold in lots of	Unit reference	Weight kg	
Vertical support for use with end fixing bracket	1	TA5-XB02	3.450	
End fixing brackets (adjustable depth) for use on pre-slotted mounting plates	1 x 100 mm module	2	AK3-XF1C	0.100
	2 x 100 mm modules	1	AK3-XF2C	0.200
	3 x 100 mm modules	1	AK3-XF3C	0.300
1/4 turn screw + clip-in clasp for fixing bracket AK3-XF1C on the vertical support	10	AK3-XM1T	0.085	
Locating peg for vertical positioning of the tap-off outlet	10	AK3-XM1P	0.095	

#### Supply to control circuits

Description	Reference	Weight kg
Lot of 4 busway supports (designed to take 1 to 3, 2-pole busways)	TB5-XB03	0.750
2-pole busway (length 2 m, for cutting to length by the user)	TA5-XB05	0.400

#### For fixing 3 L L L mounting rails (2)

Description	Sold in lots of	Unit reference	Weight kg
Support (3) for 1 mounting rail (adjustable depth)	20	AK3-XS01	0.050
Support (3) for 3 mounting rails	10	AK3-XS02	0.120

#### Partition fixing accessories (horizontal and rear)

Description	Sold in lots of	Unit reference	Weight kg	
Self-tapping screws pushing waste material towards the outside (avoids getting swarf inside the equipment)	Ø 4 x 8 mm	100	AK3-XV48	0.002
	Ø 4 x 15 mm	100	AK3-XV415	0.002

(1) For use when increased mechanical rigidity is required: panels subjected to vibration, tap-offs incorporating heavy products.

(2) Mounting rails (to be ordered separately) for installing terminal blocks or components of varying depths.

Mounting rail fixed on support by means of Ø 4 x 15 mm self-tapping screws, fixing centres: 82.5 mm (1 module), 182.5 mm (2 modules), 282.5 mm (3 modules).

Maximum length of mounting rail: 93 mm (1 module), 193 mm (2 modules), 293 mm (3 modules).

(3) Support fixed on mounting plate by rivets or Ø 4 mm nuts/bolts (not supplied).

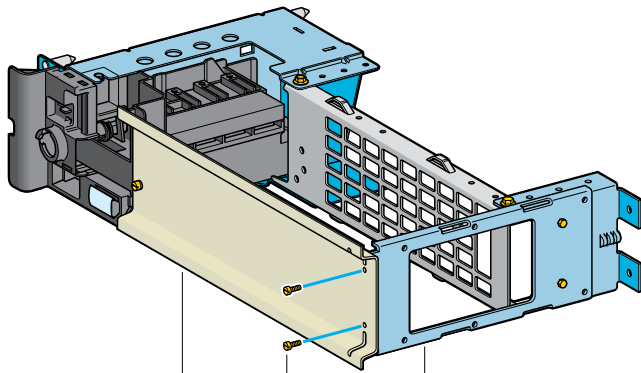

AK3-CF1P  
2 x AK3-XV415  
AK3-XS1CF

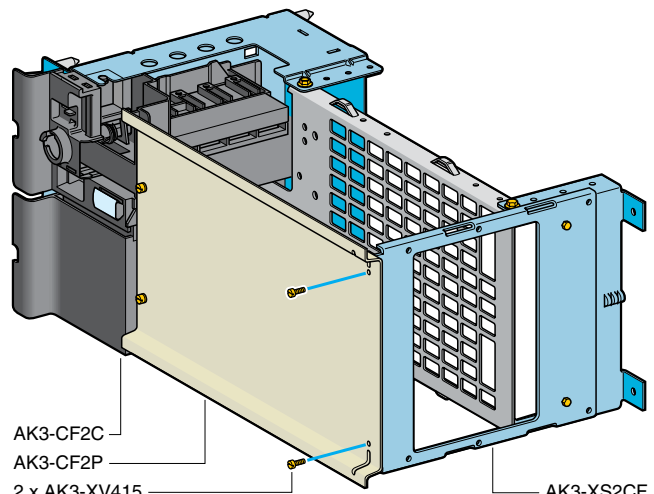

AK3-CF2C  
AK3-CF2P  
2 x AK3-XV415  
AK3-XS2CF

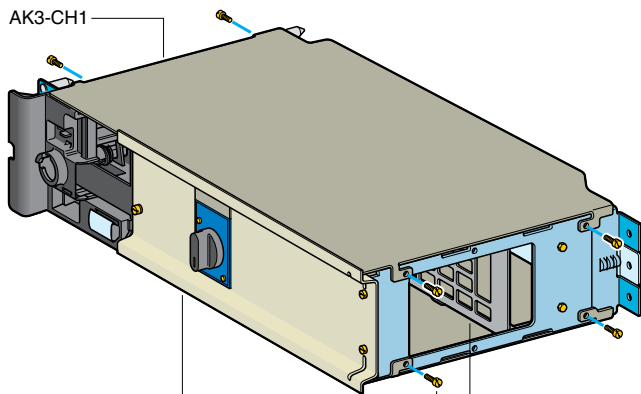

AK3-CH1

AK3-CF1D  
8 x AK3-XV48  
AK3-CH1

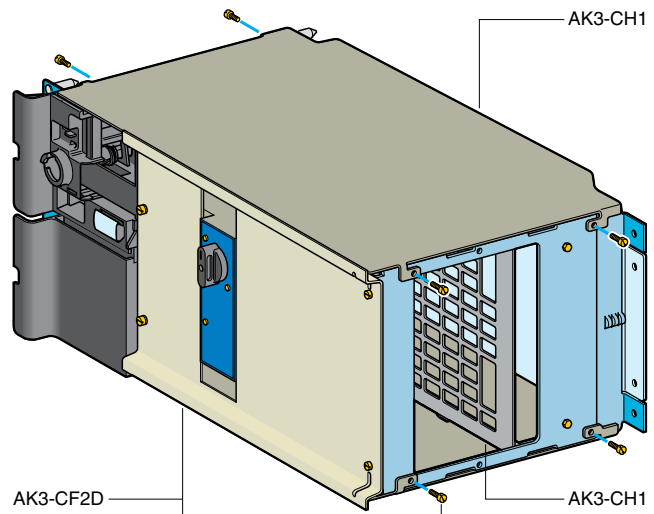

AK3-CH1

AK3-CH1  
8 x AK3-XV48  
AK3-CF2D  
AK3-CF2D6

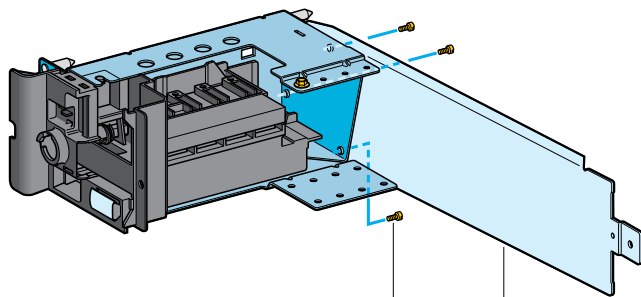

3 x AK3-XV48  
AK3-CA1

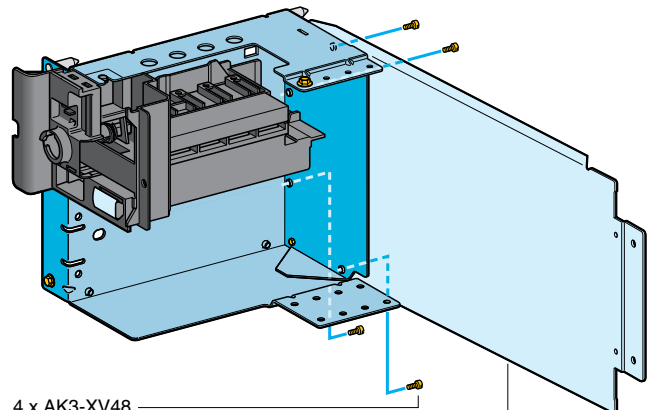

4 x AK3-XV48  
AK3-CA2



# Power distribution in control panels

## CMD® prefabricated plug-in busbar trunking

Partitioning accessories for assembly by the user  
(to be ordered separately)

### Front plates <sup>(1)</sup> colour beige RAL 7032

For use on	Cut-out	Sold in lots of	Unit reference	Weight kg
1 x 100 mm module	Without	2	AK3-CF1P	0.430
	With	2	AK3-CF1D	0.390
2 x 100 mm modules	Without	1	AK3-CF2P	0.840
	With (for integral 18 and 32)	1	AK3-CF2D	0.740
	With (for Integral 63)	1	AK3-CF2D6	0.740
3 x 100 mm modules	Without	1	AK3-CF3P	1.230
	With (for integral 18 and 32)	1	AK3-CF3D	1.110
	With (for Integral 63)	1	AK3-CF3D6	1.110
	With (for Integral 63 reverser)	1	AK3-CF3D66	1.110

### Front plate supports <sup>(2)</sup>

1 x 100 mm module	–	2	AK3-XS1CF	0.230
2 x 100 mm modules	–	1	AK3-XS2CF	0.450
3 x 100 mm modules	–	1	AK3-XS3CF	0.670

### Additional front plate <sup>(3)</sup>

Description	Sold in lots of	Unit reference	Weight kg
For use with AK3-SB● mounting plate supports or disconnect blocks AK3-BS142, BS143 or BS243	1	AK3-CF2C	0.060

### Horizontal partitioning <sup>(4)</sup>

Can be mounted at top or bottom, by inverting	2	AK3-CH1	0.720
---	---	---------	-------

### Rear partitioning <sup>(5)</sup>

For use on	Sold in lots of	Unit reference	Weight kg
1 x 100 mm module	2	AK3-CA1	0.520
2 x 100 mm modules	1	AK3-CA2	1.000
3 x 100 mm modules	1	AK3-CA3	1.480

*(1) Prevents access from the front to the inside of the assembly.*

*Can be used to mount control and signalling units.*

*Front plates with cut-out (width 45 mm) are designed to accommodate the operating knob of flush-mounting products.*

*Fixed to the front plate support by 2 Ø 4 x 15 mm self-tapping screws (see page 13221/5) and 1 Ø 5 mm nut/bolt (not supplied).*

*(2) Pre-fitted with fixing bracket AK3-XF●C.*

*For use with front plate or horizontal partitioning.*

*Fixed by rivets or Ø 4 mm nuts/bolts, not supplied.*

*(3) Fixing screws supplied.*

*(4) Fixing by Ø 4 x 8 mm self-tapping screws (see page 13221/5).*

*(5) Can be used to mount components. Pre-fitted with end brackets. Fixing by Ø 4 x 8 mm self-tapping screws (see page 13221/5).*



**Protective cover for busbar head**  
AK3-XCP (1)

**Insulated busbar support blocks**  
AK3-XS05, XS10

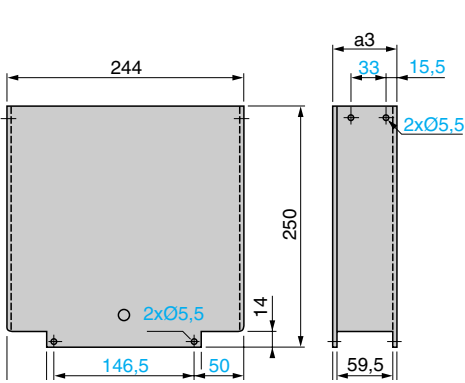

(1) Comprising 2 identical parts.

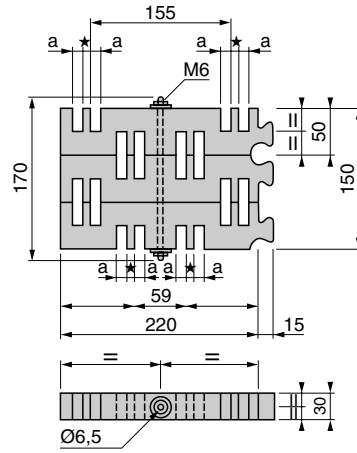

	a	★
<b>AK3-XS05</b>	5.5	8
<b>AK3-XS10</b>	10.5	8

**Mounting of tap-off outlet on the busbar**

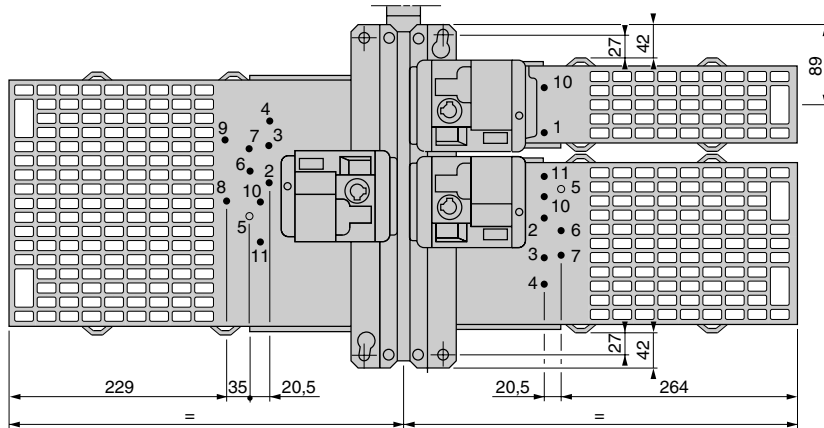

**Positioning of mounting plate using front plate and/or mechanical interlock**

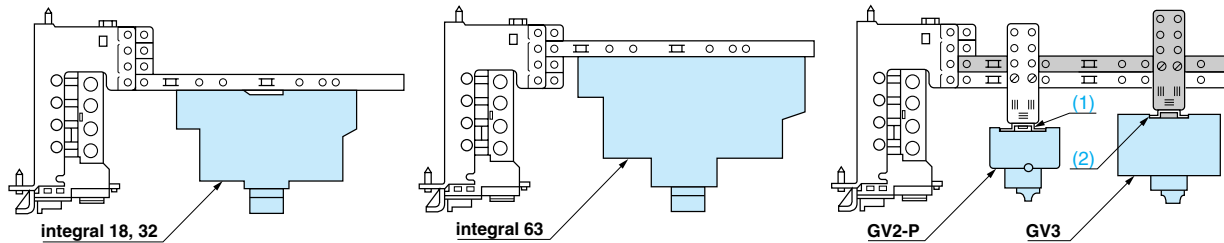

(1) for GV2-P:  $\perp$  35x15  
 (2) for GV3:  $\perp$  35x7.5

**Possibilities for mounting Integral 18, 32 or 63 on AK3- mounting plate**

integral	<b>Integral 18</b>					
Block of 5 contacts	LD1-LB030 +			LD5-LB130 +		
Block of 1 contact	LA1-LB015 +			LA1-LB015 +		
Block of 2 contacts	LA1-LB001 +			LA1-LB001 +		
Block of 5 contacts	LA1-LB031			-		
Block of 1 contact	-			LA1-LB021 +		
	-			LA1-LB001		
● Mounting possible						
<b>Mounting on plate AK3-</b>	<b>PL1</b>	<b>PL2</b>	<b>PL3</b>	<b>PL1</b>	<b>PL2</b>	<b>PL3</b>
With top partition (1)	●	●	●	-	●	●
With front plate	●	●	●	-	●	●
Number of modules occupied	1	2	3	-	2	3
Fixing hole reference numbers (1)	10	10	10	-	11	11

integral	<b>Integral 32</b>									<b>Integral 63</b>								
Block of 6 contacts	LD1-LC030 +			LD1-LC040 +			LD5-LC130 +			LD5-LC130 +			LD1-LD030 +			LD5-LD130 +		
Tripping device	LA1-LC010 +			LA1-LC010 +			LA1-LC010 +			LA1-LC010 +			LA1-LC010 +			LA1-LC010 +		
Reset device	LA1-LC07● +			LA1-LC07● +			LA1-LC07● +			LA1-LC07● +			LA1-LC07● +			LA1-LC07● +		
Block of 3 contacts	LA1-LC05● (2)			LA1-LC05●			-			LA1-LC05● +			LA1-LC05●			LA1-LC05● +		
	-			-			LA1-LC021			LA1-LC021			-			LA1-LC021		
● Mounting possible																		
<b>Mounting on plate AK3-</b>	<b>PL1</b>	<b>PL2</b>	<b>PL3</b>	<b>PL1</b>	<b>PL2</b>	<b>PL3</b>	<b>PL1</b>	<b>PL2</b>	<b>PL3</b>	<b>PL1</b>	<b>PL2</b>	<b>PL3</b>	<b>PL1</b>	<b>PL2</b>	<b>PL3</b>	<b>PL1</b>	<b>PL2</b>	<b>PL3</b>
With top partition (1)	-	●	●	-	●	●	-	●	●	-	-	●	-	●	●	-	-	●
With front plate	-	●	●	-	●	●	-	●	●	-	-	●	-	●	●	-	-	●
Number of modules occupied	2	2	3	2	2	3	-	2	3	-	3	3	-	2	3	-	3	3
Fixing hole reference numbers (1)	1	2	2	1	2+3	2+3	-	2+4	2+4	-	2+4	2+4	-	6+7	6+7	-	-	8+9

(1) By using the fixing holes indicated, the bottom partition and AK3-DV1 mechanical interlock device can be fitted if necessary.

(2) If reset device LA1-LC05● is not required, mounting on plate AK3-PL1 is possible with top partition and front plate. The number of modules occupied is 1.