



Acti9

Low voltage

Catalogue 07/2019

The efficiency you deserve

se.com

Life Is On

Schneider
Electric

Protection, Circuit protection

Acti9 iC40N circuit breakers

6000 A / 10 kA



IEC/EN 60947-2
IEC/EN 60898-1

As per the above standards:
Circuit breakers which combine the following functions:

- circuit protection against short-circuit currents,
- circuit protection against overload currents,
- suitable for isolation.



Catalog numbers

Acti9 iC40N circuit breakers								
Type	1P+N			3P		3P+N		
Auxiliaries	Catalog module CA907002							
Vigi	Catalog module CA902053							
Rating (In)	B curve	C curve	D curve	C curve	D curve	B curve	C curve	D curve
2 A	-	A9P54602	A9P64602	-	-	-	-	-
4 A	-	A9P54604	-	-	-	-	-	-
6 A	A9P44606	A9P54606	A9P64606	A9P54306	A9P64306	A9P44706	A9P54706	A9P64706
10 A	A9P44610	A9P54610	A9P64610	A9P54310	A9P64310	A9P44710	A9P54710	A9P64710
13 A	A9P44613	A9P54613	A9P64613	A9P54313	A9P64313	A9P44713	A9P54713	A9P64713
16 A	A9P44616	A9P54616	A9P64616	A9P54316	A9P64316	A9P44716	A9P54716	A9P64716
20 A	A9P44620	A9P54620	A9P64620	A9P54320	A9P64320	A9P44720	A9P54720	A9P64720
25 A	A9P44625	A9P54625	A9P64625	A9P54325	A9P64325	A9P44725	A9P54725	A9P64725
32 A	A9P44632	A9P54632	A9P64632	A9P54332	A9P64332	A9P44732	A9P54732	A9P64732
40 A	A9P44640	A9P54640	A9P64640	A9P54340	A9P64340	A9P44740	A9P54740	A9P64740
Width in 9-mm modules	2			6		6		
Accessories	Catalog modules CA907001 and CA907015							
Comb busbars	Catalog module CA907026							
PowerTag energy sensors	Catalog modules CA907029 and CA908058							



Protection, Circuit protection

Acti9 iC40N circuit breakers 6000 A / 10 kA

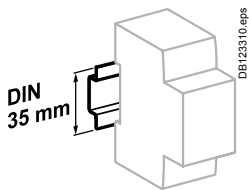

Clip on DIN rail 35 mm.

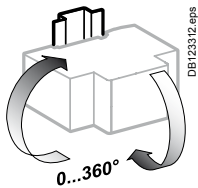

Indifferent position of installation.

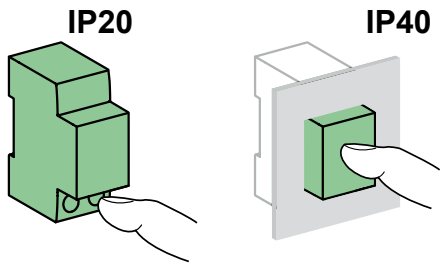

Dimensions (mm)

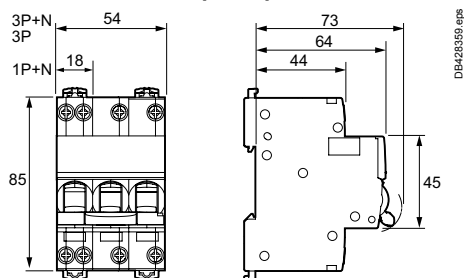

Technical data

Main characteristics		Acti9 iC40N	
Insulation voltage (Ui)	Phase-to-neutral	400 V	
	Phase-to-phase	440 V	
Voltage rating (Ue)	Phase-to-neutral	230 V	
	Phase-to-phase	400 V	
Operating frequency		50/60 Hz	
According to IEC/EN 60898-1			
Limitation class		3	
Rated breaking capacity (Icn)		6000 A	
Service breaking capacity (Ics)		100 % Icn	
Rated breaking and making capacity on a single pole (Icn1)		Icn1 = Icn	
Magnetic tripping	B curve	3 to 5 In	
	C curve	5 to 10 In	
	D curve	10 to 14 In	
Operating temperature		30°C	
According to IEC/EN 60947-2			
Rated impulse withstand voltage (Uimp)		4 kV	
Breaking capacity (Icu)		10 kA	
Service breaking capacity (Ics)	3P	75 % Icu	
	1P+N, ≤ 25 A	75 % Icu	
	3P+N, ≥ 32 A	50 % Icu	
Magnetic tripping	B curve	4 In ±20 %	
	C curve	8 In ±20 %	
	D curve	12 In ±20 %	
Operating temperature		50°C	
Pollution degree		3	
Additional characteristics			
Degree of protection (IEC 60529)	Device only	IP20	
	Device in modular enclosure	IP40 Insulation class II	
Endurance (O-C)	Electrical	≤ 20 A	20000 cycles
		≥ 25 A	10000 cycles
	Mechanical	20000 cycles	
Operating temperature		-25°C to +70°C	
Storage temperature		-40°C to +85°C	

Weight (g)

Circuit breakers		Acti9 iC40N
Type		
1P+N		120
3P		340
3P+N		345

Protection, Circuit protection Acti9 iC40 circuit breakers

- Automatic cable guiding in the correct position: terminals with guard
- Reinforced cable pull-out strength: serrated terminals
- Where there is a comb tooth, the connection of cables of cross section 16 mm² remains possible
- Assembly and disassembly with comb busbar in place by operating toggle latches at the top and bottom of the products
- Insulated terminals IP20
- **VISI-TRIP window**
■ Fault tripping is indicated by a red mechanical indicator on the front face
- **VISI-SAFE window**
■ Positive contact indication
■ A green strip on the toggle indicates full opening of all the poles
■ Downstream maintenance operations can be carried out in better safety conditions
■ Padlocking possible
- **Markings**
■ Area for marking by 12 mm high label on the front panel
- **Markings**
■ Area for 4 marking clips alongside the downstream terminal

Connection

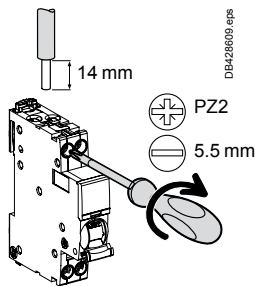

Type	Connection	Tightening torque	Comb busbar	Copper cables	
				Rigid	Flexible or with ferrule
Acti9 iC40	Top	2 N.m	■	1 to 16 mm ²	1 to 10 mm ²
	Bottom		■		

- Connection by comb busbar or cables (as per EN 50027).
- Where there is a comb tooth, the connection of cables of cross section 16 mm² remains possible.
- See Choice of Comb busbars (CA908048).

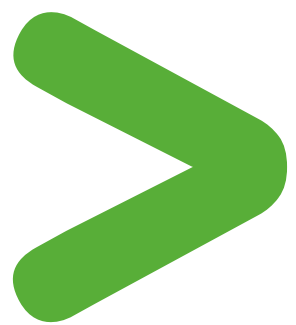

Protection Circuit protection

iC60N double terminals circuit breakers (curve B, C, D)

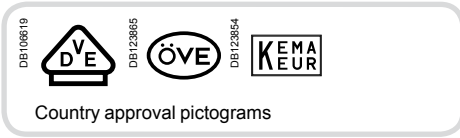

IEC/EN 60947-2 IEC/EN 60898-1

- iC60N double tunnel terminals circuit breakers are multi-standard circuit breakers which combine the following functions:
 - circuit protection against short-circuit currents,
 - circuit protection against overload currents,
 - suitable for industrial isolation according to IEC/EN 60947-2, standard.
 - fault tripping indication by a red mechanical indicator in circuit breaker front face.

Alternating current (AC) 50/60 Hz

Breaking capacity (Icu) according to IEC/EN 60947-2	Voltage (Ue)				Service breaking capacity (Ics)
	12 to 133 V	220 to 240 V	380 to 415 V	440 V	
Ph/Ph (2P, 3P, 3P+N, 4P)					
Ph/N (1P, 1P+N)	12 to 60 V	100 to 133 V	220 to 240 V	-	
Rating (In)	0.5 to 4 A 6 to 63 A	50 kA 36 kA	50 kA 20 kA	50 kA 10 kA	25 kA 6 kA
					100 % of Icu 75 % of Icu

Breaking capacity (Icn) according to IEC/EN 60898-1	
Ph/Ph	Voltage (Ue)
Ph/Ph	400 V
Ph/N	230 V
Rating (In)	0.5 to 63 A 6000 A

Direct current (DC)

Breaking capacity (Icu) according to IEC/EN 60947-2	Voltage (Ue)					Service breaking capacity (Ics)
	12 to 60 V	≤ 72 V	≤ 125 V	≤ 180 V	≤ 250 V	
Between +/-						
Number of poles	1P		2P	3P	4P	
Rating (In)	1 to 63 A	15 kA	10 kA	10 kA	10 kA	100 % of Icu

Catalogue numbers

iC60N double terminals circuit breaker

Type	1P	1P+N	2P
Auxiliaries	Remote tripping and indication, module CA907000 and CA907002	Remote tripping and indication, module CA907000 and CA907002	Remote tripping and indication, module CA907000 and CA907002
Vigi iC60	Vigi iC60 add-on residual current device, module CA902005	Vigi iC60 add-on residual current device, module CA902005	Vigi iC60 add-on residual current device, module CA902005
Rating (In)	Curve B C D	Curve B C	Curve B C D
0.5 A	- A9F04170 A9F05170	- A9F04670	- A9F04270 A9F05270
1 A	A9F03101 A9F04101 A9F05101	- A9F04601	- A9F04201 A9F05201
2 A	A9F03102 A9F04102 A9F05102	- A9F04602	A9F03202 A9F04202 A9F05202
3 A	- A9F04103 A9F05103	- A9F04603	- A9F04203 A9F05203
4 A	A9F03104 A9F04104 A9F05104	- A9F04604	A9F03204 A9F04204 A9F05204
6 A	A9F03106 A9F04106 A9F05106	A9F03606 A9F04606	A9F03206 A9F04206 A9F05206
10 A	A9F03110 A9F04110 A9F05110	A9F03610 A9F04610	A9F03210 A9F04210 A9F05210
13 A	A9F03113 A9F04113 A9F05113	A9F03613 A9F04613	A9F03213 A9F04213 A9F05213
16 A	A9F03116 A9F04116 A9F05116	A9F03616 A9F04616	A9F03216 A9F04216 A9F05216
20 A	A9F03120 A9F04120 A9F05120	A9F03620 A9F04620	A9F03220 A9F04220 A9F05220
25 A	A9F03125 A9F04125 A9F05125	A9F03625 A9F04625	A9F03225 A9F04225 A9F05225
32 A	A9F03132 A9F04132 A9F05132	A9F03632 A9F04632	A9F03232 A9F04232 A9F05232
40 A	A9F03140 A9F04140 A9F05140	A9F03640 A9F04640	A9F03240 A9F04240 A9F05240
50 A	A9F03150 A9F04150 A9F05150	A9F03650 A9F04650	A9F03250 A9F04250 A9F05250
63 A	A9F03163 A9F04163 A9F05163	A9F03663 A9F04663	A9F03263 A9F04263 A9F05263
Width in 9-mm modules	2	4	4
Accessories	Modules CA907000 and CA907001	Modules CA907000 and CA907001	Modules CA907000 and CA907001

Protection
Circuit protection

iC60N double terminals circuit breakers (curve B, C, D) (cont.)

- Insulated terminals IP20**
- Double terminals**
 - For top or bottom connections:
 - by cable,
 - by comb busbar
- Large circuit labelling area**
- Double clip locking** allowing tool-free removal, front panel side, with the comb busbar in position
- Visi-trip window**
 - Fault tripping is indicated by a red mechanical indicator on the front face
- Positive contact indication**
 - Suitable for industrial isolation according to IEC/EN 60947-2 standard
 - The presence of the green strip guarantees physical opening of the contacts and allows operations to be performed on the downstream circuit in complete safety
- Increased product service life thanks to:**
 - overvoltage resistance by high level of industrial performances conception (pollution degree, rated impulse withstand voltage and insulation voltage),
 - high performance limitation (see limitation curves),
 - fast closing independent of the speed of actuation of the toggle.
 - Remote indication, open/closed/tripped, by optional auxiliary contacts.
 - Top or bottom electrical feeding.

3P			3P+N			4P		
Remote tripping and indication, module CA907000 and CA907002			Remote tripping and indication, module CA907000 and CA907002			Remote tripping and indication, module CA907000 and CA907002		
Vigi iC60 add-on residual current device, module CA902005			Vigi iC60 add-on residual current device, module CA902005			Vigi iC60 add-on residual current device, module CA902005		
Curve			Curve			Curve		
B	C	D	B	C	B	C	D	
-	A9F04370	A9F05370	-	A9F04770	-	A9F04470	A9F05470	
-	A9F04301	A9F05301	-	A9F04701	-	A9F04401	A9F05401	
A9F03302	A9F04302	A9F05302	-	A9F04702	-	A9F04402	A9F05402	
-	A9F04303	A9F05303	-	A9F04703	-	A9F04403	A9F05403	
-	A9F04304	A9F05304	-	A9F04704	-	A9F04404	A9F05404	
A9F03306	A9F04306	A9F05306	A9F03706	A9F04706	A9F03406	A9F04406	A9F05406	
A9F03310	A9F04310	A9F05310	A9F03710	A9F04710	A9F03410	A9F04410	A9F05410	
A9F03313	A9F04313	A9F05313	A9F03713	A9F04713	A9F03413	A9F04413	A9F05413	
A9F03316	A9F04316	A9F05316	A9F03716	A9F04716	A9F03416	A9F04416	A9F05416	
A9F03320	A9F04320	A9F05320	A9F03720	A9F04720	A9F03420	A9F04420	A9F05420	
A9F03325	A9F04325	A9F05325	A9F03725	A9F04725	A9F03425	A9F04425	A9F05425	
A9F03332	A9F04332	A9F05332	A9F03732	A9F04732	A9F03432	A9F04432	A9F05432	
A9F03340	A9F04340	A9F05340	A9F03740	A9F04740	A9F03440	A9F04440	A9F05440	
A9F03350	A9F04350	A9F05350	A9F03750	A9F04750	A9F03450	A9F04450	A9F05450	
A9F03363	A9F04363	A9F05363	A9F03763	A9F04763	A9F03463	A9F04463	A9F05463	
6			8			8		
Modules CA907000 and CA907001			Modules CA907000 and CA907001			Modules CA907000 and CA907001		

Protection
Circuit protection

iC60N double terminals circuit breakers (curve B, C, D) (cont.)

Connection between double terminal circuit breakers

With comb busbar at the back/cables at the front

Without comb busbar at the back/cables at the front

DBA04815



		Back	Front	
Rating	Tightening torque	Comb busbar	Copper cables	
		Thickness of the teeth	Rigid	Flexible or with ferrule
0.5 to 25 A	2 N.m	1.5 mm	DB122945	DB122946
32 to 63 A	3.5 N.m	1.5 mm	1 to 25 mm ²	1 to 16 mm ²
			1 to 25 mm ²	1 to 25 mm ²

Between double terminal circuit breakers and single-terminal circuit breakers

Cables at the back/comb busbar at the front

DBA04817

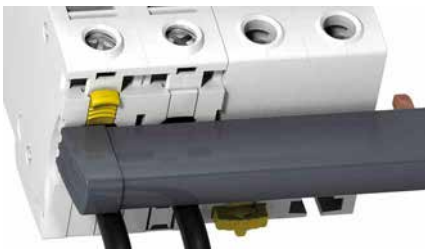

		Back	Front	
Rating	Tightening torque	Copper cables		Comb busbar
		Rigid	Flexible or with ferrule	Thickness of the teeth
0.5 to 25 A	2 N.m	DB122945	DB122946	
32 to 63 A	3.5 N.m	1 to 16 mm ²	1 to 10 mm ²	1.5 mm
		1 to 16 mm ²	1 to 10 mm ²	1.5 mm

■ Connection by comb busbar or by cable (according to EN 50027).

Connection

DB123847

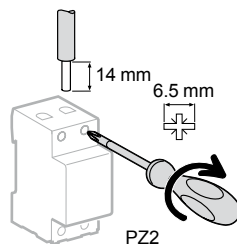

With accessories

Rating	50 mm ² Al terminal	Screw-on connection for ring terminal	Multi-cables terminal	
			Rigid cables	Flexible cables
0.5 to 25 A	DB122935	DB118789	DB118787	
32 to 63 A	50 mm ²	Ø 5 mm	3 x 16 mm ²	3 x 10 mm ²

Protection Circuit protection

iC60N double terminals circuit breakers (curve B, C, D) (cont.)

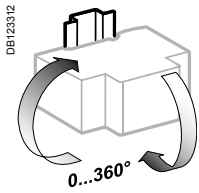

Indifferent position of installation.

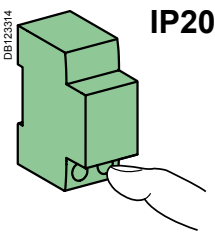

IP20

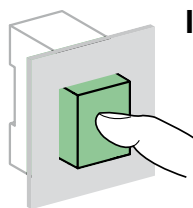

IP40

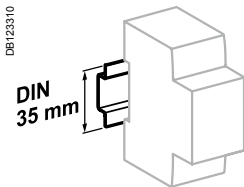

Clip on DIN rail 35 mm.

Technical data

Main characteristics

According to IEC/EN 60947-2

Insulation voltage (Ui)	500 V AC	
Pollution degree	3	
Rated impulse withstand voltage (Uimp)	6 kV	
Thermal tripping	Reference temperature	50°C
	Temperature derating	See module CA908007
Magnetic tripping	B curve	4 In ± 20 %
	C curve	8 In ± 20 %
	D curve	12 In ± 20 %
Utilization category	A	

According to IEC/EN 60898-1

Limitation class	3
Rated making and breaking capacity of an individual pole (Icn1)	Icn1 = Icn

Additional characteristics

Degree of protection (IEC 60529)	Device only	IP20
	Device in modular enclosure	IP40 Insulation class II
Endurance (O-C)	Electrical	10,000 cycles
	Mechanical	20,000 cycles
Overvoltage category (IEC 60364)	IV	
Operating temperature	-35°C to +70°C	
Storage temperature	-40°C to +85°C	
Tropicalization (IEC 60068-1)	Treatment 2 (relative humidity 95 % to 55°C)	

Disassembly double terminals iC60 circuit breaker with the comb busbar in position

Comb busbar downstream



Comb busbar upstream



- 1- Pull lower "clip locking"
- 2- Pull upper "clip locking"
- 3- Remove the circuit breaker

Dimensions (mm)

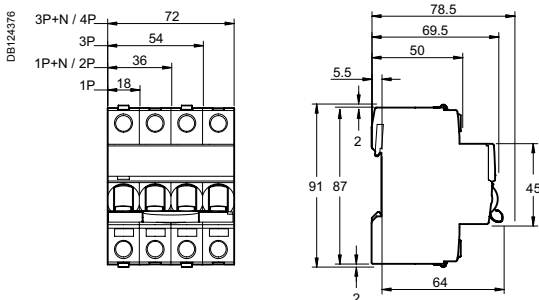

Weight (g)

Circuit-breaker

Type	iC60N
1P	125
2P (1P+N)	250
3P	375
4P (3P+N)	500

Protection Circuit protection

iC60H double terminals circuit breakers (curve B, C, D)



IEC/EN 60947-2 IEC/EN 60898-1

- iC60H double terminal terminals circuit breakers are multi-standard circuit breakers which combine the following functions:
 - circuit protection against short-circuit currents,
 - circuit protection against overload currents,
 - suitable for industrial isolation according to IEC/EN 60947-2, standard.
 - fault tripping indication by a red mechanical indicator in circuit breaker front face.

Alternating current (AC) 50/60 Hz

Breaking capacity (Icu) according to IEC/EN 60947-2	Voltage (Ue)				Service breaking capacity (Ics)
	Ph/Ph (2P, 3P, 4P)	12 to 133 V	220 to 240 V	380 to 415 V 440 V	
Ph/N (1P, 1P+N)	12 to 60 V	100 to 133 V	220 to 240 V	-	
Rating (In)	0.5 to 4 A	70 kA	70 kA	70 kA	100 % of Icu
	6 to 40 A	42 kA	30 kA	15 kA	50 % of Icu
	50/63 A	42 kA	30 kA	15 kA	50 % of Icu

Breaking capacity (Icn) according to IEC/EN 60898-1

Breaking capacity (Icn) according to IEC/EN 60898-1	Voltage (Ue)	
	Ph/Ph	400 V
Ph/N	230 V	
Rating (In)	0.5 to 63 A	10000 A

Direct current (DC)

Breaking capacity (Icu) according to IEC/EN 60947-2	Voltage (Ue)					Service breaking capacity (Ics)
	Between +/-	12 to 60 V	≤ 72 V	≤ 125 V	≤ 180 V ≤ 250 V	
Number of poles	1P		2P	3P	4P	
Rating (In)	1 to 63 A	20 kA	15 kA	15 kA	15 kA	100 % of Icu

Catalogue numbers

iC60H double terminals circuit breaker

Type	1P	1P+N	2P																																																																			
Auxiliaries	Remote tripping and indication, module CA907000 and CA907002	Remote tripping and indication, module CA907000 and CA907002	Remote tripping and indication, module CA907000 and CA907002																																																																			
Vigi iC60	Vigi iC60 add-on residual current device, module CA902005	Vigi iC60 add-on residual current device, module CA902005	Vigi iC60 add-on residual current device, module CA902005																																																																			
Rating (In)	<table border="1"> <thead> <tr> <th rowspan="2">Curve</th> <th colspan="3">Curve</th> </tr> <tr> <th>B</th> <th>C</th> <th>D</th> </tr> </thead> <tbody> <tr> <td>0.5 A</td> <td>-</td> <td>A9F07170</td> <td>A9F08170</td> </tr> <tr> <td>1 A</td> <td>-</td> <td>A9F07101</td> <td>A9F08101</td> </tr> <tr> <td>2 A</td> <td>-</td> <td>A9F07102</td> <td>A9F08102</td> </tr> <tr> <td>3 A</td> <td>-</td> <td>A9F07103</td> <td>A9F08103</td> </tr> <tr> <td>4 A</td> <td>-</td> <td>A9F07104</td> <td>A9F08104</td> </tr> <tr> <td>6 A</td> <td>A9F06106</td> <td>A9F07106</td> <td>A9F08106</td> </tr> <tr> <td>10 A</td> <td>A9F06110</td> <td>A9F07110</td> <td>A9F08110</td> </tr> <tr> <td>13 A</td> <td>A9F06113</td> <td>A9F07113</td> <td>A9F08113</td> </tr> <tr> <td>16 A</td> <td>A9F06116</td> <td>A9F07116</td> <td>A9F08116</td> </tr> <tr> <td>20 A</td> <td>A9F06120</td> <td>A9F07120</td> <td>A9F08120</td> </tr> <tr> <td>25 A</td> <td>A9F06125</td> <td>A9F07125</td> <td>A9F08125</td> </tr> <tr> <td>32 A</td> <td>A9F06132</td> <td>A9F07132</td> <td>A9F08132</td> </tr> <tr> <td>40 A</td> <td>A9F06140</td> <td>A9F07140</td> <td>A9F08140</td> </tr> <tr> <td>50 A</td> <td>A9F06150</td> <td>A9F07150</td> <td>A9F08150</td> </tr> <tr> <td>63 A</td> <td>A9F06163</td> <td>A9F07163</td> <td>A9F08163</td> </tr> </tbody> </table>			Curve	Curve			B	C	D	0.5 A	-	A9F07170	A9F08170	1 A	-	A9F07101	A9F08101	2 A	-	A9F07102	A9F08102	3 A	-	A9F07103	A9F08103	4 A	-	A9F07104	A9F08104	6 A	A9F06106	A9F07106	A9F08106	10 A	A9F06110	A9F07110	A9F08110	13 A	A9F06113	A9F07113	A9F08113	16 A	A9F06116	A9F07116	A9F08116	20 A	A9F06120	A9F07120	A9F08120	25 A	A9F06125	A9F07125	A9F08125	32 A	A9F06132	A9F07132	A9F08132	40 A	A9F06140	A9F07140	A9F08140	50 A	A9F06150	A9F07150	A9F08150	63 A	A9F06163	A9F07163	A9F08163
Curve	Curve																																																																					
	B	C	D																																																																			
0.5 A	-	A9F07170	A9F08170																																																																			
1 A	-	A9F07101	A9F08101																																																																			
2 A	-	A9F07102	A9F08102																																																																			
3 A	-	A9F07103	A9F08103																																																																			
4 A	-	A9F07104	A9F08104																																																																			
6 A	A9F06106	A9F07106	A9F08106																																																																			
10 A	A9F06110	A9F07110	A9F08110																																																																			
13 A	A9F06113	A9F07113	A9F08113																																																																			
16 A	A9F06116	A9F07116	A9F08116																																																																			
20 A	A9F06120	A9F07120	A9F08120																																																																			
25 A	A9F06125	A9F07125	A9F08125																																																																			
32 A	A9F06132	A9F07132	A9F08132																																																																			
40 A	A9F06140	A9F07140	A9F08140																																																																			
50 A	A9F06150	A9F07150	A9F08150																																																																			
63 A	A9F06163	A9F07163	A9F08163																																																																			
Width in 9-mm modules	2	4	4																																																																			
Accessories	Modules CA907000 and CA907001	Modules CA907000 and CA907001	Modules CA907000 and CA907001																																																																			

Protection Circuit protection

iC60H double terminals circuit breakers (curve B, C, D) (cont.)

- Insulated terminals IP20**
- Double terminals**
 - For top or bottom connections:
 - by cable,
 - by comb busbar
- Large circuit labelling area**
- Double clip locking** allowing tool-free removal, front panel side, with the comb busbar in position
- Visi-trip window**
 - Fault tripping is indicated by a red mechanical indicator on the front face
- Positive contact indication**
 - Suitable for industrial isolation according to IEC/EN 60947-2 standard
 - The presence of the green strip guarantees physical opening of the contacts and allows operations to be performed on the downstream circuit in complete safety
- Increased product service life thanks to:**
 - overtoltage resistance by high level of industrial performances conception (pollution degree, rated impulse withstand voltage and insulation voltage),
 - high performance limitation (see limitation curves),
 - fast closing independent of the speed of actuation of the toggle.
 - Remote indication, open/closed/tripped, by optional auxiliary contacts.
 - Top or bottom electrical feeding.

3P				4P			
Remote tripping and indication, module CA907000 and CA907002				Remote tripping and indication, module CA907000 and CA907002			
Vigi iC60 add-on residual current device, module CA902005				Vigi iC60 add-on residual current device, module CA902005			
Curve				Curve			
B	C	D	B	C	D		
-	A9F07370	A9F08370	-	A9F07470	A9F08470		
-	A9F07301	A9F08301	-	A9F07401	A9F08401		
-	A9F07302	A9F08302	-	A9F07402	A9F08402		
-	A9F07303	A9F08303	-	A9F07403	A9F08403		
-	A9F07304	A9F08304	-	A9F07404	A9F08404		
A9F06306	A9F07306	A9F08306	A9F06406	A9F07406	A9F08406		
A9F06310	A9F07310	A9F08310	A9F06410	A9F07410	A9F08410		
A9F06313	A9F07313	A9F08313	A9F06413	A9F07413	A9F08413		
A9F06316	A9F07316	A9F08316	A9F06416	A9F07416	A9F08416		
A9F06320	A9F07320	A9F08320	A9F06420	A9F07420	A9F08420		
A9F06325	A9F07325	A9F08325	A9F06425	A9F07425	A9F08425		
A9F06332	A9F07332	A9F08332	A9F06432	A9F07432	A9F08432		
A9F06340	A9F07340	A9F08340	A9F06440	A9F07440	A9F08440		
A9F06350	A9F07350	A9F08350	A9F06450	A9F07450	A9F08450		
A9F06363	A9F07363	A9F08363	A9F06463	A9F07463	A9F08463		
6			8				
Modules CA907000 and CA907001				Modules CA907000 and CA907001			

Protection
Circuit protection

iC60H double terminals circuit breakers (curve B, C, D) (cont.)

Connection between double terminal circuit breakers

With comb busbar at the back/cables at the front

Without comb busbar at the back/cables at the front

DBA04815



		Back	Front	
Rating	Tightening torque	Comb busbar	Copper cables	
		Thickness of the teeth	Rigid	Flexible or with ferrule
			DB122945	DB122946
0.5 to 25 A	2 N.m	1.5 mm	1 to 25 mm ²	1 to 16 mm ²
32 to 63 A	3.5 N.m	1.5 mm	1 to 25 mm ²	1 to 25 mm ²

Between double terminal circuit breakers and single-terminal circuit breakers

Cables at the back/comb busbar at the front

DBA04817



		Back	Front	
Rating	Tightening torque	Copper cables		Thickness of the teeth
		Rigid	Flexible or with ferrule	
		DB122945	DB122946	
0.5 to 25 A	2 N.m	1 to 16 mm ²	1 to 10 mm ²	1.5 mm
32 to 63 A	3.5 N.m	1 to 16 mm ²	1 to 10 mm ²	1.5 mm

■ Connection by comb busbar or by cable (according to EN 50027).

Connection

DB123847

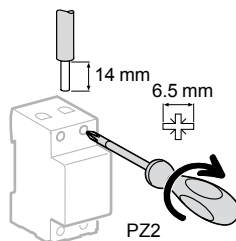

With accessories

Rating	50 mm ² AI terminal	Screw-on connection for ring terminal	Multi-cables terminal	
			Rigid cables	Flexible cables
	DB122935	DB118789	DB118787	
0.5 to 25 A	-	Ø 5 mm	-	-
32 to 63 A	50 mm ²		3 x 16 mm ²	3 x 10 mm ²

Protection
Circuit protection

iC60H double terminals circuit breakers (curve B, C, D) (cont.)

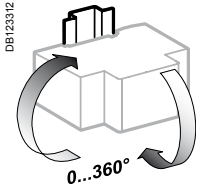

Indifferent position of installation.

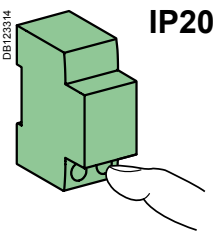

IP20

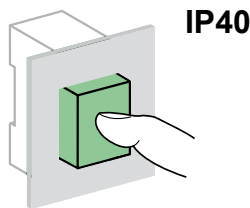

IP40

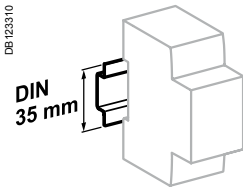

Clip on DIN rail 35 mm.

Technical data

Main characteristics

According to IEC/EN 60947-2

Insulation voltage (Ui)	500 V AC	
Pollution degree	3	
Rated impulse withstand voltage (Uimp)	6 kV	
Thermal tripping	Reference temperature	50°C
	Temperature derating	See module CA908007
Magnetic tripping	B curve	4 In ± 20 %
	C curve	8 In ± 20 %
	D curve	12 In ± 20 %
Utilization category	A	

According to IEC/EN 60898-1

Limitation class	3
Rated making and breaking capacity of an individual pole (Icn1)	Icn1 = Icn

Additional characteristics

Degree of protection (IEC 60529)	Device only	IP20
	Device in modular enclosure	IP40 Insulation class II
Endurance (O-C)	Electrical	10,000 cycles
	Mechanical	20,000 cycles
Overvoltage category (IEC 60364)	IV	
Operating temperature	-35°C to +70°C	
Storage temperature	-40°C to +85°C	
Tropicalization (IEC 60068-1)	Treatment 2 (relative humidity 95 % to 55°C)	

Disassembly double terminals iC60 circuit breaker with the comb busbar in position

Comb busbar downstream



Comb busbar upstream

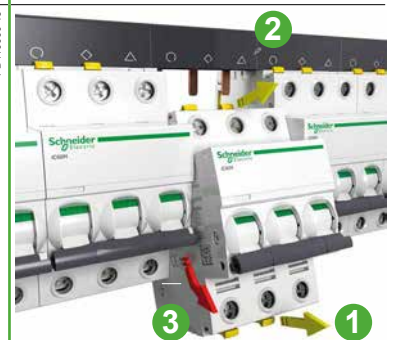

- 1- Pull lower "clip locking"
- 2- Pull upper "clip locking"
- 3- Remove the circuit breaker

Dimensions (mm)

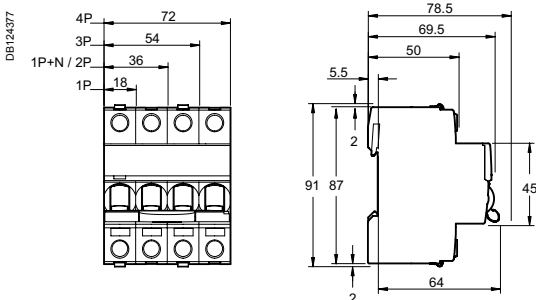

Weight (g)

Circuit-breaker

Type	iC60H
1P	125
2P (1P+N)	250
3P	375
4P	500

Protection Circuit protection iC60L circuit breakers (curve B, C, K, Z)



IEC/EN 60947-2 IEC/EN 60898-1 up to 40 A

- iC60L circuit breakers are multi-standard circuit breakers which combine the following functions:
 - circuit protection against short-circuit currents,
 - circuit protection against overload currents,
 - suitable for industrial isolation according to IEC/EN 60947-2, standard.
 - fault tripping indication by a red mechanical indicator in circuit breaker front face.

Alternating current (AC) 50/60 Hz

Breaking capacity (Icu) according to IEC/EN 60947-2						Service breaking capacity (Ics)
		Voltage (Ue)				
Ph/Ph (2P, 3P, 4P)		12 to 133 V	220 to 240 V	380 to 415 V	440 V	100 % of Icu
Ph/N (1P)		12 to 60 V	100 to 133 V	220 to 240 V	-	
Rating (In)	0.5 to 4 A	100 kA	100 kA	100 kA	70 kA	100 % of Icu
	6 to 25 A	70 kA	50 kA	25 kA	20 kA	50 % of Icu ⁽¹⁾
	32 / 40 A	70 kA	36 kA	20 kA	15 kA	50 % of Icu
	50 / 63 A	70 kA	30 kA	15 kA	10 kA	50 % of Icu

Breaking capacity (Icn) according to IEC/EN 60898-1	
Voltage (Ue)	
Ph/Ph	400 V
Ph/N	230 V
Rating (In)	0.5 to 40 A 15000 A

Direct current (DC)

Breaking capacity (Icu) according to IEC/EN 60947-2						Service breaking capacity (Ics)	
		Voltage (Ue)					
Between +/-		12 to 60 V	≤ 72 V	≤ 125 V	≤ 180 V	≤ 250 V	100 % of Icu
Number of poles		1P		2P	3P	4P	
Rating (In)	0.5 to 63 A	25 kA	20 kA	20 kA	20 kA	20 kA	

Catalogue numbers

iC60L circuit breaker

Type	1P	2P						
Auxiliaries	Remote tripping and indication, module CA907000 and CA907002	Remote tripping and indication, module CA907000 and CA907002						
Vigi iC60	Vigi iC60 add-on residual current device, module CA902005	Vigi iC60 add-on residual current device, module CA902005						
Rating (In)	Curve				Curve			
Quality label (2)								
	B	C	K	Z	B	C	K	Z
0.5 A	A9F93170	A9F94170	A9F95170	A9F92170	A9F93270	A9F94270	A9F95270	A9F92270
1 A	A9F93101	A9F94101	A9F95101	A9F92101	A9F93201	A9F94201	A9F95201	A9F92201
1.6 A	-	-	A9F95172	A9F92172	-	-	A9F95272	A9F92272
2 A	A9F93102	A9F94102	A9F95102	A9F92102	A9F93202	A9F94202	A9F95202	A9F92202
3 A	A9F93103	A9F94103	A9F95103	A9F92103	A9F93203	A9F94203	A9F95203	A9F92203
4 A	A9F93104	A9F94104	A9F95104	A9F92104	A9F93204	A9F94204	A9F95204	A9F92204
6 A	A9F93106	A9F94106	A9F95106	A9F92106	A9F93206	A9F94206	A9F95206	A9F92206
10 A	A9F93110	A9F94110	A9F95110	A9F92110	A9F93210	A9F94210	A9F95210	A9F92210
16 A	A9F93116	A9F94116	A9F95116	A9F92116	A9F93216	A9F94216	A9F95216	A9F92216
20 A	A9F93120	A9F94120	A9F95120	A9F92120	A9F93220	A9F94220	A9F95220	A9F92220
25 A	A9F93125	A9F94125	A9F95125	A9F92125	A9F93225	A9F94225	A9F95225	A9F92225
32 A	A9F93132	A9F94132	A9F95132	A9F92132	A9F93232	A9F94232	A9F95232	A9F92232
40 A	A9F93140	A9F94140	A9F95140	A9F92140	A9F93240	A9F94240	A9F95240	A9F92240
50 A	A9F93150	A9F94150	A9F95150 ⁽³⁾	A9F92150	A9F93250	A9F94250	A9F95250	A9F92250
63 A	A9F93163	A9F94163	A9F95163 ⁽³⁾	A9F92163	A9F93263	A9F94263	A9F95263	A9F92263
Width in 9-mm modules	2				4			
Accessories	Module CA907000 and CA907001				Module CA907000 and CA907001			

(1) 100 % of Icu for ratings 6 to 25 A under Ue 100 to 133 V AC Ph/Ph and Ue 12 to 60 V AC Ph/N.

(2) Information to be provided by the country.

(3) Without approval

Protection Circuit protection

iC60L circuit breakers (curve B, C, K, Z) (cont.)

PB 104436-40



3P				4P			
Remote tripping and indication, module CA907000 and CA907002				Remote tripping and indication, module CA907000 and CA907002			
Vigi iC60 add-on residual current device, module CA902005				Vigi iC60 add-on residual current device, module CA902005			
Curve		Curve		Curve		Curve	
B	C	K	Z	B	C	K	Z
A9F93370	A9F94370	A9F95370	A9F92370	A9F93470	A9F94470	A9F95470	A9F92470
A9F93301	A9F94301	A9F95301	A9F92301	A9F93401	A9F94401	A9F95401	A9F92401
-	-	A9F95372	A9F92372	-	-	A9F95472	A9F92472
A9F93302	A9F94302	A9F95302	A9F92302	A9F93402	A9F94402	A9F95402	A9F92402
A9F93303	A9F94303	A9F95303	A9F92303	A9F93403	A9F94403	A9F95403	A9F92403
A9F93304	A9F94304	A9F95304	A9F92304	A9F93404	A9F94404	A9F95404	A9F92404
A9F93306	A9F94306	A9F95306	A9F92306	A9F93406	A9F94406	A9F95406	A9F92406
A9F93310	A9F94310	A9F95310	A9F92310	A9F93410	A9F94410	A9F95410	A9F92410
A9F93316	A9F94316	A9F95316	A9F92316	A9F93416	A9F94416	A9F95416	A9F92416
A9F93320	A9F94320	A9F95320	A9F92320	A9F93420	A9F94420	A9F95420	A9F92420
A9F93325	A9F94325	A9F95325	A9F92325	A9F93425	A9F94425	A9F95425	A9F92425
A9F93332	A9F94332	A9F95332	A9F92332	A9F93432	A9F94432	A9F95432	A9F92432
A9F93340	A9F94340	A9F95340	A9F92340	A9F93440	A9F94440	A9F95440	A9F92440
A9F93350	A9F94350	A9F95350	A9F92350	A9F93450	A9F94450	A9F95450	A9F92450
A9F93363	A9F94363	A9F95363	A9F92363	A9F93463	A9F94463	A9F95463	A9F92463
4				6			
Module CA907000 and CA907001				Module CA907000 and CA907001			

iC60L circuit breakers (curve B, C, K, Z) (cont.)

Connection

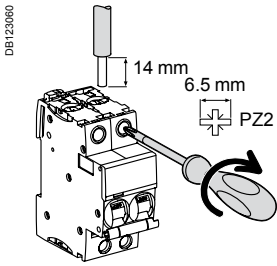

Rating	Tightening torque	Without accessory		With accessories		
		Rigid	Flexible or with ferrule	50 mm ² Al terminal	Screw-on connection for ring terminal	Multi-cables terminal
0.5 to 25 A	2 N.m	DB1122945	DB1122946	DB1122935	DB118789	DB118787
32 to 63 A	3.5 N.m	1 to 25 mm ²	1 to 16 mm ²	-	Ø 5 mm	-
		1 to 35 mm ²	1 to 25 mm ²	50 mm ²	-	3 x 16 mm ²
						3 x 10 mm ²

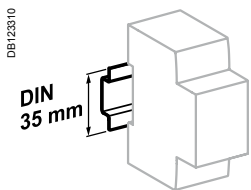

Clip on DIN rail 35 mm.

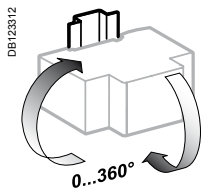

Indifferent position of installation.

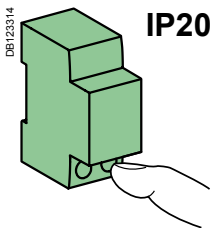

IP20

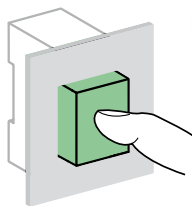

IP40

Technical data

Main characteristics

According to IEC/EN 60947-2

Insulation voltage (U _i)	500 V AC	
Pollution degree	3	
Rated impulse withstand voltage (U _{imp})	6 kV	
Thermal tripping	Reference temperature	50 °C
	Temperature derating	See module CA908007
Magnetic tripping	B curve	4 I _n ± 20 %
	C curve	8 I _n ± 20 %
	K curve	12 I _n ± 20 %
	Z curve	3 I _n ± 20 %
Utilization category	A	

According to IEC/EN 60898-1

Rated making and breaking capacity of an individual pole (I _{cn1})	I _{cn1} = I _{cn}	
--	------------------------------------	--

Additional characteristics

Breaking capacity under 1 pole with IT 380-415 V isolated neutral system (case of double fault)	40 A	4 kA
	50/63 A	3 kA
Degree of protection (IEC 60529)	Device only	IP20
	Device in modular enclosure	IP40
		Insulation class II
Endurance (O-C)	Electrical	10,000 cycles
	Mechanical	20,000 cycles
Overvoltage category (IEC 60364)	IV	
Operating temperature	-35°C to +70°C	
Storage temperature	-40°C to +85°C	
Tropicalization (IEC 60068-1)	Treatment 2 (relative humidity 95 % to 55°C)	

Weight (g)

Circuit-breaker	
Type	iC60L
1P	125
2P	250
3P	375
4P	500

Dimensions (mm)

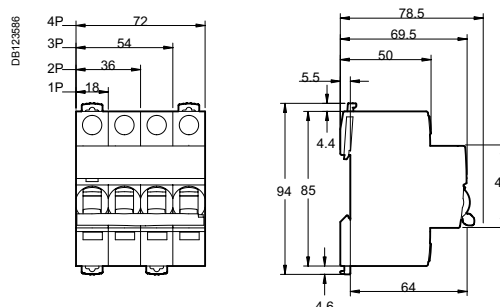

C120N circuit breakers (curves C, D)

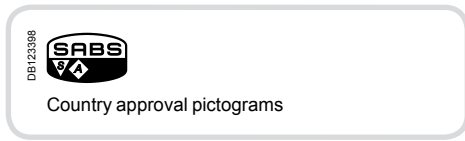

IEC/EN 60947-2

C120N circuit breakers are multistandard circuit breakers that combine the following functions:

- circuit protection against short-circuit currents,
- circuit protection against overload currents,
- suitability for isolation in the industrial sector to IEC/EN 60947-2,
- fault tripping and indication by adding auxiliaries.

Alternating current (AC) 50/60 Hz		
Breaking capacity (Icu) to IEC/EN 60947-2		Service breaking capacity (Ics)
Type	Voltage (V)	
1P, 2P, 3P, 4P	230 to 400 V	75 % of Icu
Rating (In)	80 and 100 A 10 kA	

Direct current (DC)					
Breaking capacity (Icu) according to IEC/EN 60947-2					Service breaking capacity (Ics)
Between +/-	Voltage (Ue)				
	12 to 125 V ≤ 144 V	≤ 250 V	≤ 375 V	≤ 500 V	100 % of Icu
Number of poles	1P	2P	3P	4P	
Rating (In)	80 and 100 A 15 kA	10 kA	10 kA	10 kA	

Catalogue numbers

C120N circuit breaker									
Type	1P		2P		3P		4P		
Auxiliaries	Remote indication and tripping, module CA907008 and CA907013		Remote indication and tripping, module CA907008 and CA907013		Remote indication and tripping, module CA907008 and CA907013		Remote indication and tripping, module CA907008 and CA907013		
Vigi C120	Vigi C120 add-on residual current device, module CA902016		Vigi C120 add-on residual current device, module CA902016		Vigi C120 add-on residual current device, module CA902016		Vigi C120 add-on residual current device, module CA902016		
Rating (In)	Curve C D		Curve C D		Curve C D		Curve C D		
80 A	A9N60729	A9N60745	A9N60733	A9N60749	A9N60737	A9N60753	A9N60741	A9N60757	
100 A	A9N60730	A9N60746	A9N60734	A9N60750	A9N60738	A9N60754	A9N60742	A9N60758	
Width in 9-mm modules	3		6		9		12		
Accessories	Module CA907012 and CA907013		Module CA907012 and CA907013		Module CA907012 and CA907013		Module CA907012 and CA907013		

Protection

Circuit protection

C120 circuit breakers

PB107817-40

■ Terminals insulated to IP20



■ Location for 4 clip-on terminal markers

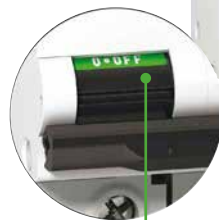

Positive contact indication

- Suitability for isolation in the industrial sector to IEC/EN 60947-2.
- The presence of the green strip guarantees that the contacts open physically and allows work to be carried out safely on the downstream circuit.

- Longer product service life thanks to:
 - good overvoltage withstand capacity: products designed to offer a high industrial performance level (degree of pollution, rated impulse withstand voltage and insulation voltage).
 - high limitation performances (see limitation curves).
 - fast closure independent of toggle operating speed.
- Remote indication of the open/closed/tripped state by auxiliary contacts (optional).
- Power supply from above or below.

Protection Circuit protection C120 circuit breakers (cont.)

Connection

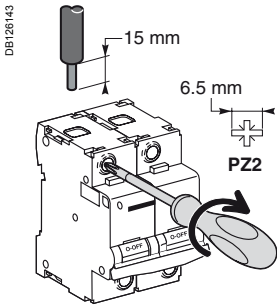

Rating	Tightening torque	Without access.		With accessories			
		Rigid/semi-rigid	Flexible or with ferrule	50 mm ² Al Terminal	Screw-on connection for ring terminal ⁽¹⁾	Rigid cables	Flexible cables
		DB122845	DB122846	DB122835	DB118789	DB118787	
80 and 100 A	3.5 N.m	1.5 to 50 mm ²	1.5 to 35 mm ²	16 to 50 mm ²	Ø 5 mm	3 x 16 mm ²	3 x 10 mm ²

(1) For lugs up to 63 A, front or rear access.

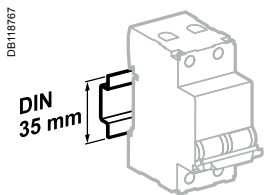

Clips onto 35 mm DIN rail.

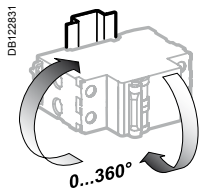

Any installation position.

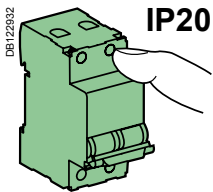

IP20

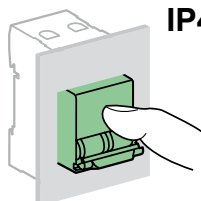

IP40

Technical data

Main characteristics

To IEC/EN 60947-2

Insulation voltage (Ui)	500 V AC	
Degree of pollution	3	
Rated impulse withstand voltage (Uimp)	6 kV	
Thermal tripping	Reference temperature	50°C
Magnetic tripping	Curve C	8 In ± 20 %
	Curve D	12 In ± 20 %
Limitation class	3	

Additional characteristics

Degree of protection (IEC 60529)	Device only	IP20
	Device in a modular enclosure	IP40
Endurance (O-C)	Electrical	5000 cycles (O-C)
	Mechanical	20000 cycles
Operating temperature	-30°C to +70°C	
Storage temperature	-40°C to +80°C	
Tropicalisation (IEC 60068-1)	Treatment 2 (relative humidity 95 % at 55°C)	

Weight (g)

Circuit breaker

Type	C120
1P	205
2P	410
3P	615
4P	820

Dimensions (mm)

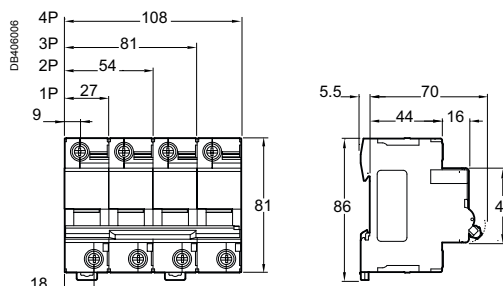

Protection

Circuit protection

C120N circuit breakers (curves B, C, D)

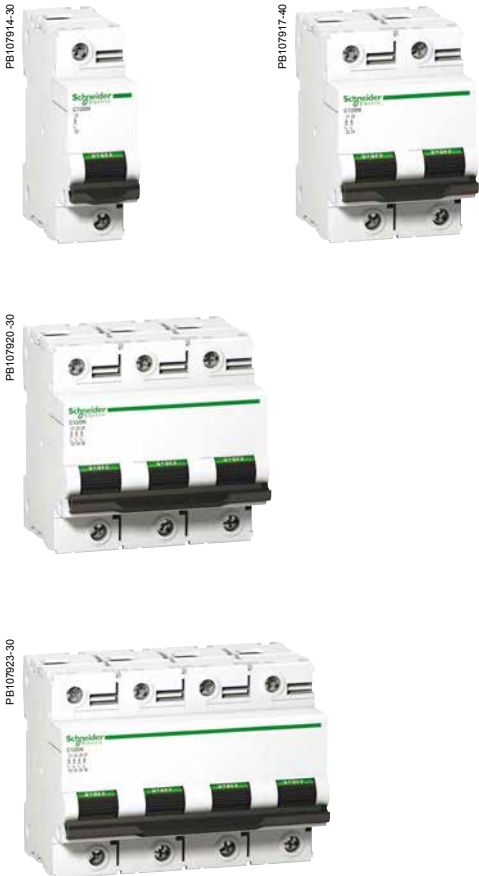

IEC/EN 60898-1

C120N circuit breakers are multistandard circuit breakers that combine the following functions:

- circuit protection against short-circuit currents,
- circuit protection against overload currents,
- suitability for isolation in the industrial sector to IEC/EN 60947-2,
- fault tripping and indication by adding auxiliaries.

Alternating current (AC) 50/60 Hz

Breaking capacity (Icu) to IEC/EN 60947-2						Service breaking capacity (Ics)
Type	Voltage (V)					
1P	12 to 130 V	220 to 240 V	380 to 415 V	440 V		75 % of Icu
Rating (In) 63 to 125 A	20 kA	10 kA	3 kA ⁽¹⁾	-		
2P/3P/4P	12 to 130 V	220 to 240 V	380 to 415 V	440 V		75 % of Icu
63 to 125 A	-	20 kA	10 kA	6 kA		

Breaking capacity (Icn) to IEC/EN 60898-1

Type	Voltage (V)		Service breaking capacity (Ics)
1P, 2P, 3P, 4P	230 to 400 V		
Rating (In) 63 to 125 A	10000 A		

⁽¹⁾ One-pole breaking capacity in IT isolated neutral system (double fault).

Direct current (DC)

Breaking capacity (Icu) according to IEC/EN 60947-2							Service breaking capacity (Ics)
Between +/-	Voltage (Ue)						
	12 to 125 V	≤ 144 V	≤ 250 V	≤ 375 V	≤ 500 V		100 % of Icu
Number of poles	1P		2P	3P	4P		
Rating (In) 63 to 125 A	15 kA	10 kA	10 kA	10 kA	10 kA		

Catalogue numbers

C120N circuit breaker

Type	1P	2P
Auxiliaries	Remote indication and tripping, module CA907008 and CA907013	Remote indication and tripping, module CA907008 and CA907013
Vigi C120	Vigi C120 add-on residual current device, module CA902016	Vigi C120 add-on residual current device, module CA902016
Rating (In)	Curve	Curve
	B C D	B C D
63 A	A9N18340 A9N18356 A9N18378	A9N18344 A9N18360 A9N18382
80 A	A9N18341 A9N18357 A9N18379	A9N18345 A9N18361 A9N18383
100 A	A9N18342 A9N18358 A9N18380	A9N18346 A9N18362 A9N18384
125 A	A9N18343 A9N18359 A9N18381	A9N18347 A9N18363 A9N18385
Width in 9-mm modules	3	6
Accessories	Module CA907012 and CA907013	Module CA907012 and CA907013

⁽¹⁾ Country France only

Protection Circuit protection

C120N circuit breakers (curves B, C, D) (cont.)

PB107817-40

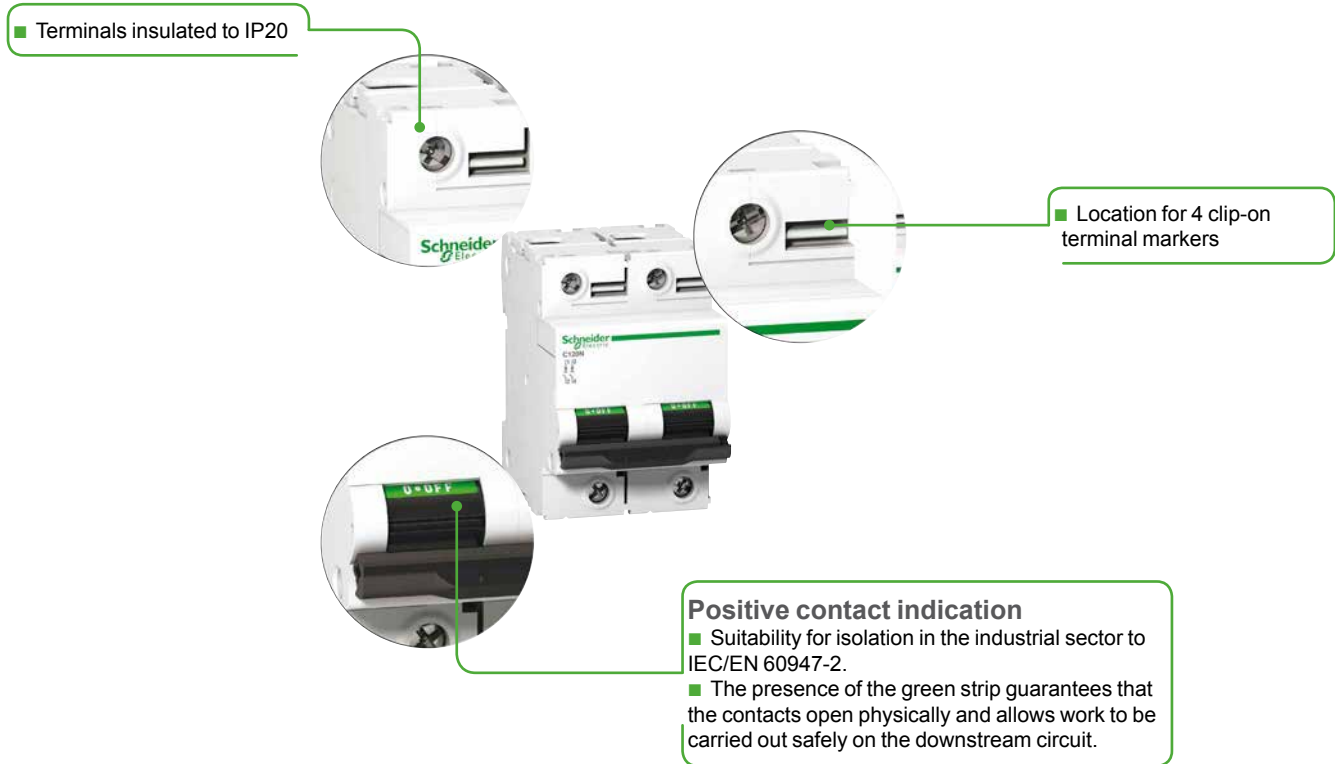

Positive contact indication

- Suitability for isolation in the industrial sector to IEC/EN 60947-2.
- The presence of the green strip guarantees that the contacts open physically and allows work to be carried out safely on the downstream circuit.

- Longer product service life thanks to:
 - good overvoltage withstand capacity: products designed to offer a high industrial performance level (degree of pollution, rated impulse withstand voltage and insulation voltage).
 - high limitation performances (see limitation curves).
 - fast closure independent of toggle operating speed.
- Remote indication of the open/closed/tripped state by auxiliary contacts (optional).
- Power supply from above or below.

3P			4P		
Remote indication and tripping, module CA907008 and CA907013			Remote indication and tripping, module CA907008 and CA907013		
Vigi C120 add-on residual current device, module CA902016			Vigi C120 add-on residual current device, module CA902016		
Curve			Curve		
B	C	D	B	C	D
A9N18348	A9N18364	A9N18386	A9N18352	A9N18371	A9N18390
A9N18349	A9N18365	A9N18387	A9N18353	A9N18372	A9N18391
A9N18350	A9N18367	A9N18388	A9N18354	A9N18373(1)	A9N18392
A9N18351	A9N18369	A9N18389	A9N18355	A9N18374	A9N18392
				A9N18375(1)	
				A9N18376	A9N18393
				A9N18377(1)	
9			12		
Module CA907012 and CA907013			Module CA907012 and CA907013		

Protection Circuit protection

C120N circuit breakers (curves B, C, D) (cont.)

Connection

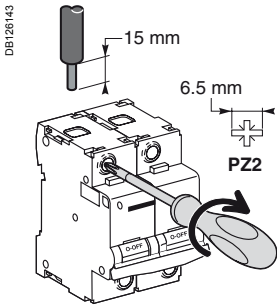

Rating	Tightening torque	Without access.		With accessories			
		Rigid/semi-rigid	Flexible or with ferrule	50 mm ² Al Terminal	Screw-on connection for ring terminal ⁽¹⁾	Multi-cable terminal	
		DB122845	DB122846	DB122835	DB118789	DB118787	
63 to 125 A	3.5 N.m	1.5 to 50 mm ²	1.5 to 35 mm ²	16 to 50 mm ²	Ø 5 mm	3 x 16 mm ²	3 x 10 mm ²

(1) For lugs up to 63 A, front or rear access.

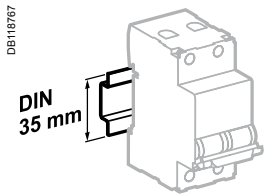

Clips onto 35 mm DIN rail.

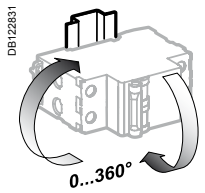

Any installation position.

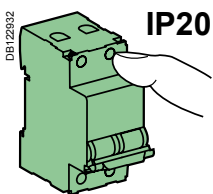

IP20

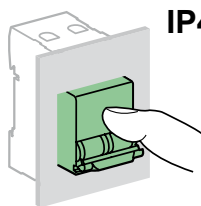

IP40

Technical data

Main characteristics

To IEC/EN 60947-2

Insulation voltage (U _i)	500 V AC
Degree of pollution	3
Rated impulse withstand voltage (U _{imp})	6 kV
Thermal tripping Reference temperature	50°C

To IEC/EN 60898-1

Magnetic tripping	Curve B	3 and 5 I _n
	Curve C	5 and 10 I _n
	Curve D	10 and 14 I _n
Limitation class	3	

Additional characteristics

Degree of protection (IEC 60529)	Device only	IP20	
	Device in a modular enclosure	IP40	
Endurance (O-C)	Electrical	63 A	10000 cycles (O-C)
		80...125 A	5000 cycles (O-C)
	Mechanical	20000 cycles	
Operating temperature	-30°C to +70°C		
Storage temperature	-40°C to +80°C		
Tropicalisation (IEC 60068-1)	Treatment 2 (relative humidity 95 % at 55°C)		

Weight (g)

Circuit breaker

Type	C120N
1P	205
2P	410
3P	615
4P	820

Dimensions (mm)

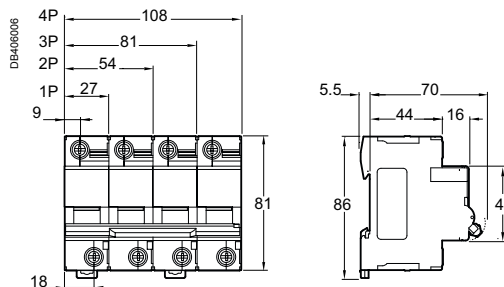

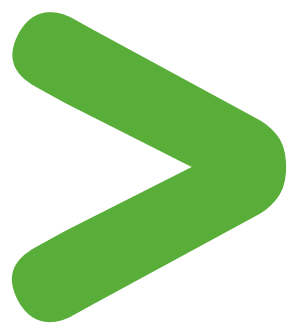

Protection

Circuit protection

C120H circuit breakers (curves B, C, D)

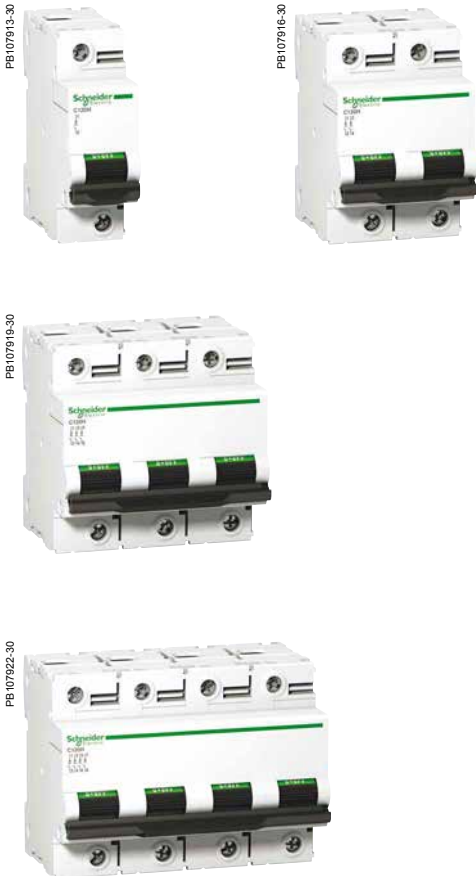

IEC/EN 60898-1

C120H circuit breakers are multistandard circuit breakers that combine the following functions:

- circuit protection against short-circuit currents
- circuit protection against overload currents
- suitability for isolation in the industrial sector to IEC/EN 60947-2
- fault tripping and indication by adding auxiliaries.

Alternating current (AC) 50/60 Hz

Breaking capacity (Icu) to IEC/EN 60947-2						Service breaking capacity (Ics)
Type	Voltage (V)					
1P	12 to 130 V	220 to 240 V	380 to 415 V	440 V		50 % of Icu
Rating (In) 63 to 125 A	30 kA	15 kA	4,5 kA ⁽¹⁾	-		
2P, 3P, 4P	12 to 130 V	220 to 240 V	380 to 415 V	440 V		50 % of Icu
63 to 125 A	-	30 kA	15 kA	10 kA		

Breaking capacity (Icn) to IEC/EN 60898-1

Type	Voltage (V)		Service breaking capacity (Ics)
1P, 2P, 3P, 4P	230 to 400 V		
Rating (In) 63 to 125 A	15000 A		

⁽¹⁾ One-pole breaking capacity in IT isolated neutral system (double fault).

Direct current (DC)

Breaking capacity (Icu) according to IEC/EN 60947-2							Service breaking capacity (Ics)
Between +/-	Voltage (Ue)						
	12 to 125 V	≤ 144 V	≤ 250 V	≤ 375 V	≤ 500 V		
Number of poles	1P	2P	3P	4P			
Rating (In) 63 to 125 A	20 kA	15 kA	15 kA	15 kA	15 kA		100 % of Icu

Catalogue numbers

C120H circuit breaker

Type	1P	2P
Auxiliaries	Remote indication and tripping, module CA907008 and CA907013	Remote indication and tripping, module CA907008 and CA907013
Vigi C120	Vigi C120 add-on residual current device, module CA902016	Vigi C120 add-on residual current device, module CA902016
Rating (In)	Curve	Curve
	B C D	B C D
63 A	A9N18401 A9N18445 A9N18489	A9N18412 A9N18456 A9N18500
80 A	A9N18402 A9N18446 A9N18490	A9N18413 A9N18457 A9N18501
100 A	A9N18403 A9N18447 A9N18491	A9N18414 A9N18458 A9N18502
125 A	A9N18404 A9N18448 A9N18492	A9N18415 A9N18459 A9N18503
Width in 9 mm modules	3	6
Accessories	Module CA907012 and CA907013	Module CA907012 and CA907013

Protection Circuit protection

C120H circuit breakers (curves B, C, D) (cont.)

PB107916-40

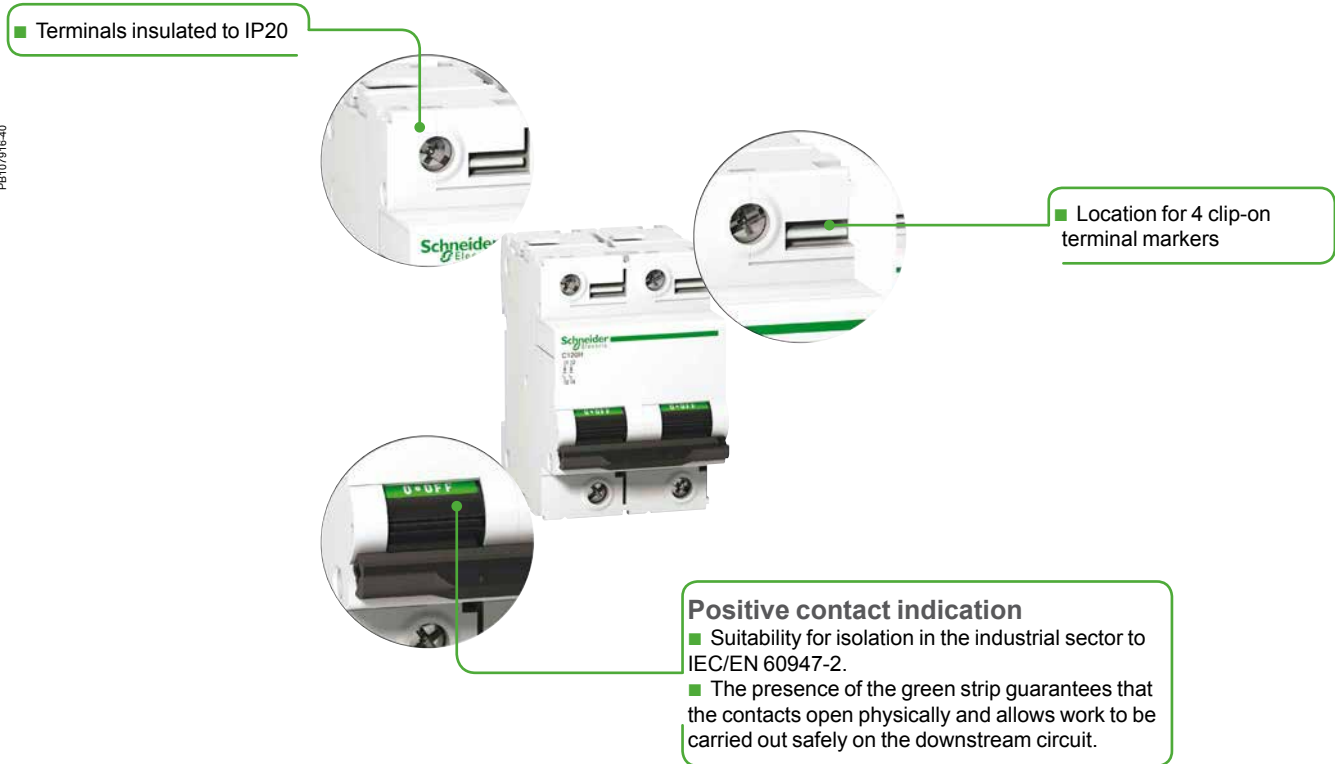

- Longer product service life thanks to:
 - good overvoltage withstand capacity: products designed to provide a high industrial performance level (degree of pollution, rated impulse withstand voltage and insulation voltage).
 - high limitation performances (see limitation curves).
 - fast closure independent of toggle operating speed.
- Remote indication of the open/closed/tripped state by auxiliary contacts (optional).
- Power supply from above or below.

3P				4P				
Remote indication and tripping, module CA907008 and CA907013				Remote indication and tripping, module CA907008 and CA907013				
Vigi C120 add-on residual current device, module CA902016				Vigi C120 add-on residual current device, module CA902016				
Curve				Curve				
B		C		D		B	C	D
A9N18423		A9N18467		A9N18511		A9N18434	A9N18478	A9N18522
A9N18424		A9N18468		A9N18512		A9N18435	A9N18479	A9N18523
A9N18425		A9N18469		A9N18513		A9N18436	A9N18480	A9N18524
A9N18426		A9N18470		A9N18514		A9N18437	A9N18481	A9N18525
9				12				
Module CA907012 and CA907013				Module CA907012 and CA907013				

Protection
Circuit protection

C120H circuit breakers (curves B, C, D) (cont.)

Connection

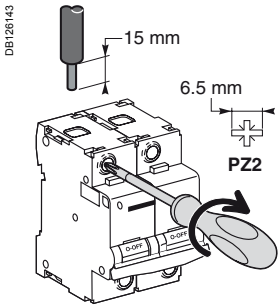

Rating	Tightening torque	Without access.		With accessories			
		Rigid	Flexible or with ferrule	50 mm ² Al term.	Screw-on connection for ring terminal ⁽¹⁾	Rigid cables	Flexible cables
63 to 125 A	3.5 N.m	DB1222445	DB1222446	DB1222435	DB1187869	DB1187867	
		1.5 to 50 mm ²	1.5 to 35 mm ²	16 to 50 mm ²	Ø 5 mm	3 x 16 mm ²	3 x 10 mm ²

(1) For lugs up to 63 A, front or rear accessories.

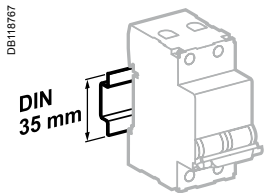

Clips onto 35 mm DIN rail.

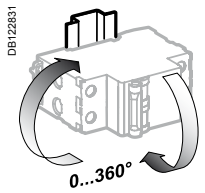

Any installation position.

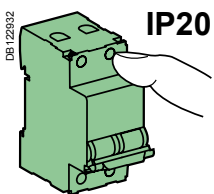

IP20

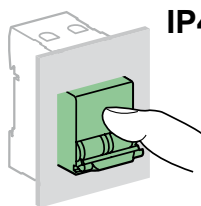

IP40

Technical data

Main characteristics

To IEC/EN 60947-2

Insulation voltage (U _i)	500 V AC	
Degree of pollution	3	
Rated impulse withstand voltage (U _{imp})	6 kV	
Thermal tripping	Reference temperature	50°C

To IEC/EN 60898-1

Magnetic tripping	Curve B	3 and 5 I _n
	Curve C	5 and 10 I _n
	Curve D	10 and 14 I _n
Limitation class		3

Additional characteristics

Degree of protection (IEC 60529)	Device only	IP20	
	Device in a modular enclosure	IP40 (IPXXD)	
Endurance (O-C)	Electrical	63 A	10000 cycles (O-C)
		80...125 A	5000 cycles (O-C)
	Mechanical		20000 cycles
Operating temperature		-30°C to +70°C	
Storage temperature		-40°C to +80°C	
Tropicalisation (IEC 60068-1)		Treatment 2 (relative humidity 95% at 55°C)	

Weight (g)

Circuit breaker

Type	C120H
1P	205
2P	410
3P	615
4P	820

Dimensions (mm)

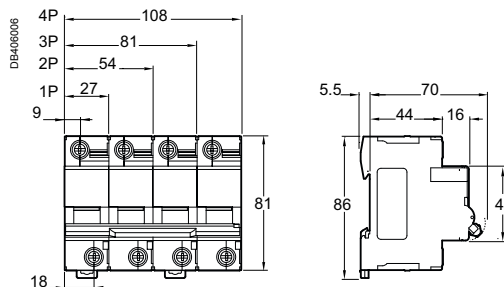

Protection Circuit protection

NG125N circuit breakers (curves B, C, D)

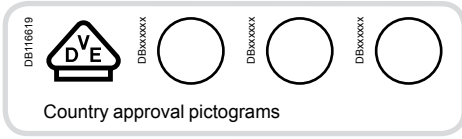

IEC/EN 60947-2

■ NG125N circuit breakers are circuit breakers which combine the following functions:

- circuit protection against short-circuit currents,
- circuit protection against overload currents,
- suitability for isolation in the industrial sector to IEC/EN 60947-2,
- tripping upon fault is indicated by a red mechanical state indicator light on the front face of the circuit breaker.



NG125N 1P



NG125N 2P



NG125N 3P



NG125N 4P

Alternating current (AC) 50/60 Hz									
Breaking capacity (Icu) to IEC/EN 60947-2									
Ph/Ph (2P, 3P, 3P+N, 4P)	Voltage (Ue)						Service breaking capacity (Ics)		
	110 to 130 V	220 to 240 V	220 to 240 V	380 to 415 V	440 V	500 V			
Rating (In)	10 to 125 A	50 kA	25 kA	50 kA	6 kA ⁽²⁾	25 kA	20 kA	10 kA	75 % of Icu

Direct current (DC)							
Breaking capacity (Icu) according to IEC/EN 60947-2							
Number of poles	Voltage (Ue)					Service breaking capacity (Ics)	
	12 to 125 V	≤ 144 V	≤ 250 V	≤ 375 V	≤ 500 V		
Rating (In)	10 to 125 A	25 kA	20 kA	20 kA	20 kA	20 kA	100 % of Icu

Catalogue numbers

NG125N circuit breaker										
Type	1P	2P	3P	3P+N	4P					
Auxiliaries	Remote indication and tripping, module CM907004 and CM907005									
Vigi NG125	Vigi NG125 add-on residual current device, module CM902008									
Rating (In)	Quality label (1)	Curve C	Curve C	Curve B	Curve C	Curve D	Curve C	Curve B	Curve C	Curve D
10 A		18610	18621	-	18632	-	-	-	18649	-
16 A		18611	18622	-	18633	-	-	-	18650	-
20 A		18612	18623	-	18634	-	-	-	18651	-
25 A		18613	18624	-	18635	-	-	-	18652	-
32 A		18614	18625	-	18636	-	-	-	18653	-
40 A		18615	18626	-	18637	-	-	-	18654	-
50 A		18616	18627	-	18638	-	-	-	18655	-
63 A		18617	18628	-	18639	-	-	-	18656	-
80 A		18618	18629	18663	18641	18669	18646	18666	18657	18672
100 A		-	-	18664	18643	18670	18647	18667	18659	18673
125 A		-	-	18665	18645	18671	18648	18668	18661	18674
Width in 9 mm modules	3	6	9				12	12		
Accessories	Module CM907004 and CM907006									

(1) Information to be supplied by the country concerned.

(2) Breaking capacity under 1 pole in IT isolated neutral system (case of a double fault).

NG125N circuit breakers (curves B, C, D) (cont.)

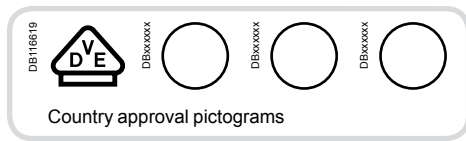

IEC/EN 60947-2

■ NG125N circuit breakers are circuit breakers which combine the following functions:

- circuit protection against short-circuit currents,
- circuit protection against overload currents,
- suitability for isolation in the industrial sector to IEC/EN 60947-2,
- tripping upon fault is indicated by a red mechanical state indicator light on the front face of the circuit breaker.



NG125N 1P



NG125N 2P



NG125N 3P







NG125N 4P

Alternating current (AC) 50/60 Hz									
Breaking capacity (Icu) to IEC/EN 60947-2									
Ph/Ph (2P, 3P, 3P+N, 4P)	Voltage (Ue)						Service breaking capacity (Ics)		
	110 to 130 V	220 to 240 V	220 to 240 V	380 to 415 V	440 V	500 V			
Ph/N (1P)	-	-	-	-	-	-	-		
Rating (In)	10 to 125 A	50 kA	25 kA	50 kA	6 kA ⁽²⁾	25 kA	20 kA	10 kA	75 % of Icu

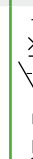
Direct current (DC)						
Breaking capacity (Icu) according to IEC/EN 60947-2						
Number of poles	Voltage (Ue)					Service breaking capacity (Ics)
	12 to 125 V	≤ 144 V	≤ 250 V	≤ 375 V	≤ 500 V	
1P	25 kA	20 kA	20 kA	20 kA	20 kA	100 % of Icu
2P						
3P						
4P						
Rating (In)	10 to 125 A					

Catalogue numbers

NG125N circuit breaker										
Type	1P	2P	3P	3P+N	4P					
										
Auxiliaries	Remote indication and tripping, module CM907004 and CM907005									
Vigi NG125	Vigi NG125 add-on residual current device, module CM902008									
Rating (In)	Quality label ⁽¹⁾	Curve	Curve	Curve	Curve	Curve	Curve	Curve	Curve	Curve
		C	C	B	C	D	C	B	C	D
10 A		18610	18621	-	18632	-	-	-	18649	-
16 A		18611	18622	-	18633	-	-	-	18650	-
20 A		18612	18623	-	18634	-	-	-	18651	-
25 A		18613	18624	-	18635	-	-	-	18652	-
32 A		18614	18625	-	18636	-	-	-	18653	-
40 A		18615	18626	-	18637	-	-	-	18654	-
50 A		18616	18627	-	18638	-	-	-	18655	-
63 A		18617	18628	-	18639	-	-	-	18656	-
80 A		18618	18629	18663	18640	18669	18646	18666	18658	18672
100 A		-	-	18664	18642	18670	18647	18667	18660	18673
125 A		-	-	18665	18644	18671	18648	18668	18662	18674
Width in 9 mm modules	3	6	9				12	12		
Accessories	Module CM907004 and CM907006									

(1) Information to be supplied by the country concerned.

(2) Breaking capacity under 1 pole in IT isolated neutral system (case of a double fault).

NG125N circuit breakers (curves B, C, D) (cont.)

Weight (g)

Circuit breaker	
Type	NG125N
1P	240
2P	480
3P	720
3P+N	960
4P	960

Dimensions (mm)

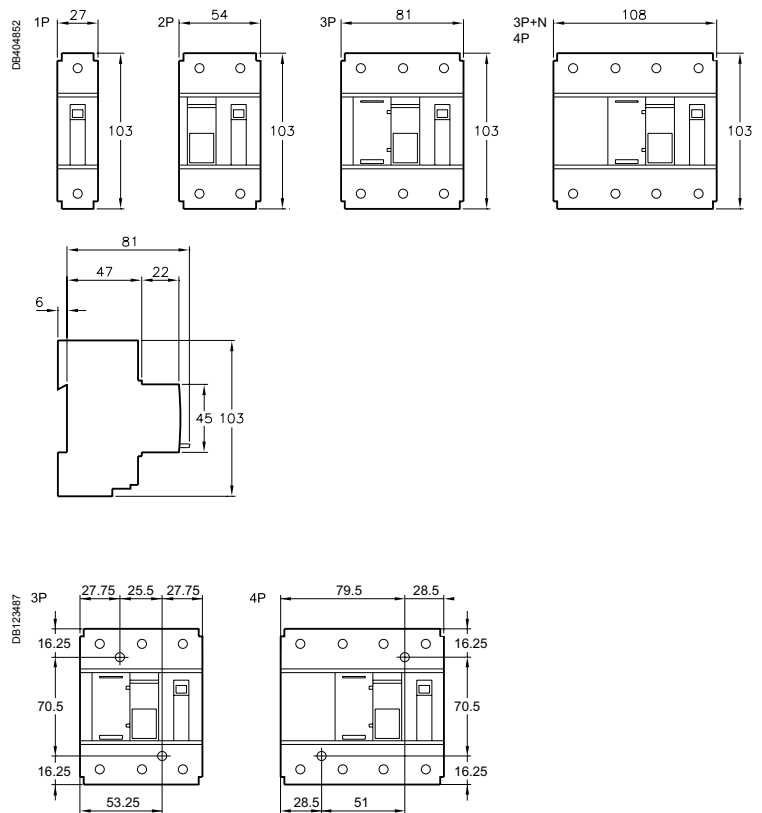

Spacing for mounting on panel

Protection Circuit protection

NG125N circuit breakers (curves B, C, D) (cont.)

056918N_SE-90

DB12483



- 3P, 4P 80 A**
- Voltage taps:
 - auxiliaries power supply
 - measurement
 - emergency stop
 - remote reporting



- 1P, 2P**
- Padlocking in position: O or I, manual control is inhibited, tripping is enabled

- Cable strength:
 - ribbed cage
 - terminal depth
 - tightening by Allen hex key (NG125 80 A)

- Test button to check satisfactory operation of the tripping mechanism



- Pull-out strength
 - metallic lock



- 3P, 4P**
- Integrated padlocking device



- Impact and vibration resistance:
 - high-strength enclosure
 - IK 05

- Circuit breaker tripped indicator

- Central manual control, 3 positions:
 - ON
 - tripped on fault
 - open

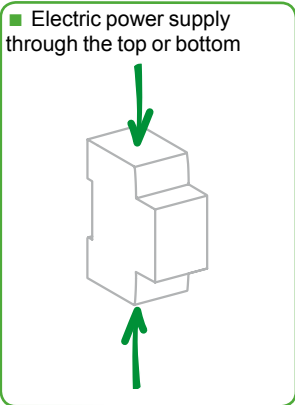

- Positive contact indication:
 - suitability for isolation in the industrial sector to IEC/EN 60947-2
 - the presence of the green strip guarantees that the contacts open physically and allows work to be carried out safely on the downstream circuit

- Longer product service life due to:
 - good overvoltage withstand capacity,
 - high limitation performances,
 - fast closure independent of the speed of actuation of the toggle.

Protection Circuit protection NG125H circuit breakers (curve C)

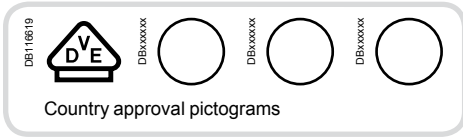

IEC/EN 60947-2

■ NG125H circuit breakers are circuit breakers which combine the following functions:

- circuit protection against short circuit currents,
- circuit protection against overload currents,
- suitability for isolation in the industrial sector to IEC/EN 60947-2,
- tripping upon fault is indicated by a red mechanical state indicator light on the front face of the circuit breaker.



056916N_SE-30
NG125H 1P



056916N_SE-30
NG125H 2P



056917N_SE-30
NG125H 3P



056918N_SE-30
NG125H 4P

Alternating current (AC) 50/60 Hz									
Breaking capacity (Icu) to IEC/EN 60947-2									
Ph/Ph (2P, 3P, 4P)	Voltage (Ue)						Service breaking capacity (Ics)		
	-	-	220 to 240 V	-	380 to 415 V	440 V		500 V	
Ph/N (1P)	110 to 130 V	220 to 240 V	-	380 to 415 V	-	-	-		
Rating (In)	10 to 80 A	70 kA	36 kA	70 kA	9 kA ⁽²⁾	36 kA	30 kA	12 kA	75 % of Icu

Direct current (DC)							
Breaking capacity (Icu) according to IEC/EN 60947-2							
	Voltage (Ue)					Service breaking capacity (Ics)	
	12 to 125 V	≤ 144 V	≤ 250 V	≤ 375 V	≤ 500 V		
Number of poles	1P		2P	3P	4P		
Rating (In)	10 to 80 A	36 kA	25 kA	25 kA	25 kA	25 kA	100 % of Icu

Catalogue numbers

NG125H circuit breaker					
Type	1P	2P	3P	4P	
	E-46902 1 2	E-46904 1 3 2 4	E-46905 1 3 5 2 4 6	E-46907 1 3 5 7 2 4 6 8	
Auxiliaries	Remote indication and tripping, module CM907004 and CM907005				
Vigi NG125	Vigi NG125 add-on residual current device, module CM902008				
Rating (In)	Quality label ⁽¹⁾	Curve C	Curve C	Curve C	Curve C
10 A		18705	18714	18723	18732
16 A		18706	18715	18724	18733
20 A		18707	18716	18725	18734
25 A		18708	18717	18726	18735
32 A		18709	18718	18727	18736
40 A		18710	18719	18728	18737
50 A		18711	18720	18729	18738
63 A		18712	18721	18730	18739
80 A		18713	18722	18731	18740
Width in 9 mm modules		3	6	9	12
Accessories	Module CM907004 and CM907006				

(1) Information to be supplied by the country concerned.

(2) Breaking capacity under 1 pole in IT isolated neutral system (case of a double fault).

NG125H circuit breakers (curve C) (cont.)

Connection

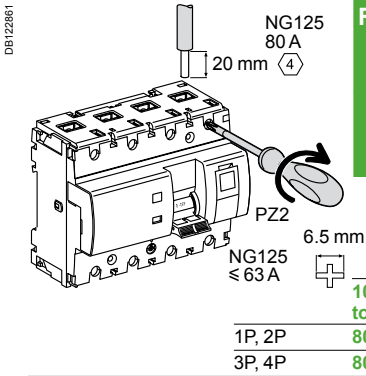

Rating	Tightening torque	Without accessories		With accessories				
		Copper cables		70 mm ² Al terminal	Screw-on connection for ring terminal	Small ring terminal	Multi-cable terminal	
		Rigid	Flexible or with ferrule	Rigid single cables			Rigid cables	Flexible cables
		DB1122945	DB1122946	DB1123410	DB1123488	DB1182769	DB1182767	
		1.5 to 50 mm ²	1.5 to 35 mm ²	-	-	-	3 x 16 mm ²	3 x 10 mm ²
1P, 2P	3.5 N.m	16 to 70 mm ²	10 to 50 mm ²	-	2 x 35 mm ² 1 x 50 mm ²	1 x 70 mm ²		
3P, 4P	6 N.m			25 to 70 mm ²				

■ On 3P and 4P 80 A: upstream voltage taps for each pole, by 6.35 mm Fast-on terminal.

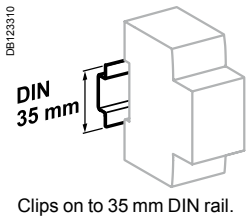

Clips on to 35 mm DIN rail.

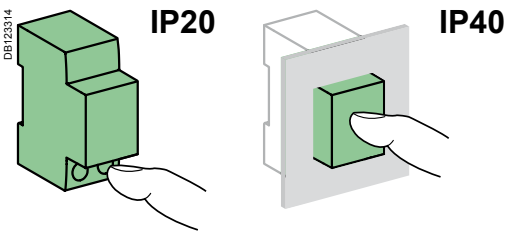

Technical data

Main characteristics

According to IEC/EN 60947-2

Insulation voltage (U _i)	690 V AC
Degree of pollution	3
Rated impulse withstand voltage (U _{imp})	8 kV
Thermal tripping	Reference temperature 40°C
Magnetic tripping (I _n)	Curve C 8 I _n ± 20 %
Utilization category	A

Additional characteristics

Degree of protection (IEC 60529)	Device only	IP20
	Device in modular enclosure	IP40
Endurance (O-C)	Electrical	≤ 63 A: 10,000 cycles ≥ 63 A: 5000 cycles
	Mechanical	20,000 cycles
Operating temperature		-30°C to +70°C
Storage temperature		-40°C to +70°C
Tropicalization (IEC 60068-1)		Treatment 2 (relative humidity of 95 % at 55°C)

NG125H circuit breakers (curve C) (cont.)

Weight (g)

Circuit breaker	
Type	NG125H
1P	240
2P	480
3P	720
4P	960

Dimensions (mm)

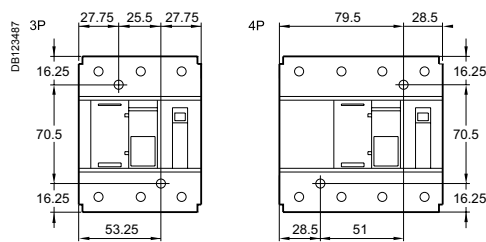
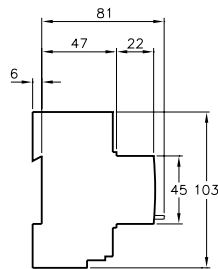
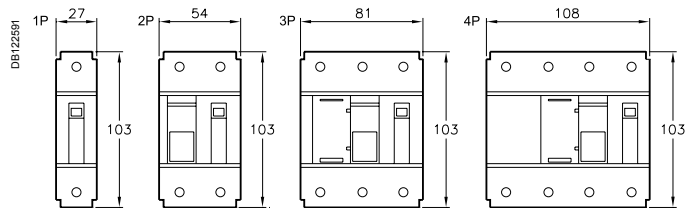

Spacing for mounting on panel

Protection

Circuit protection

NG125H circuit breakers (curve C) (cont.)

056918N_SE-90

- 3P, 4P 80 A**
- Voltage taps:
 - auxiliaries power supply
 - measurement
 - emergency stop
 - remote reporting



- Cable strength:
 - ribbed cage
 - terminal depth
 - tightening by Allen hex key (NG125 80 A)

- 1P, 2P**
- Padlocking in position: O or I, manual control is inhibited, tripping is enabled

- Test button to check satisfactory operation of the tripping mechanism



- Pull-out strength
 - metallic lock



- Impact and vibration resistance:
 - high-strength enclosure
 - IK 05

- 3P, 4P**
- Integrated padlocking device

- Central manual control, 3 positions:
 - ON
 - tripped on fault
 - open

- Circuit breaker tripped indicator

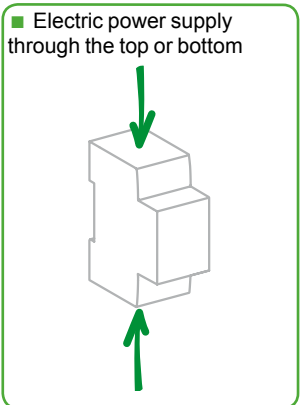

- Positive contact indication:
 - suitability for isolation in the industrial sector to IEC/EN 60947-2
 - the presence of the green strip guarantees that the contacts open physically and allows work to be carried out safely on the downstream circuit

- Longer product service life due to:
 - good overvoltage withstand capacity,
 - high limitation performances,
 - fast closure independent of the speed of actuation of the toggle.

DE 129493

Protection Circuit protection

NG125L circuit breakers (curves B, C, D) (cont.)

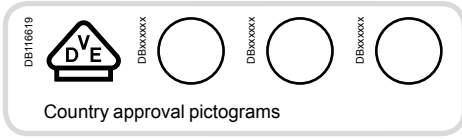

IEC/EN 60947-2

■ NG125L circuit breakers are circuit breakers which combine the following functions:

- circuit protection against short-circuit currents;
- circuit protection against overload currents;
- suitability for isolation in the industrial sector to IEC/EN 60947-2;
- tripping upon fault is indicated by a red mechanical state indicator light on the front face of the circuit breaker.



56337_SE-30
NG125L 1P



56338_SE-30
NG125L 2P



56339_SE-30
NG125L 3P



56340_SE-30
NG125L 4P

Alternating current (AC) 50/60 Hz							Service breaking capacity (Ics)
Breaking capacity (Icu) to IEC/EN 60947-2							
Voltage (Ue)							
Ph/Ph (2P, 3P, 4P)	-	-	220 to 240 V	-	380 to 415 V	440 V	500 V
Ph/N (1P)	110 to 130 V	220 to 240 V	-	380 to 415 V	-	-	-
Rating (In)	10 to 80 A	100 kA	50 kA	100 kA	12.5 kA ⁽²⁾	50 kA	40 kA
						15 kA	75 % of Icu

Direct current (DC)						Service breaking capacity (Ics)
Breaking capacity (Icu) according to IEC/EN 60947-2						
Voltage (Ue)						
	12 to 125 V	≤ 144 V	≤ 250 V	≤ 375 V	≤ 500 V	
Number of poles	1P		2P	3P	4P	
Rating (In)	10 to 80 A	50 kA	36 kA	36 kA	36 kA	100 % of Icu

Catalogue numbers

NG125L circuit breaker													
Type	1P			2P			3P			4P			
Auxiliaries	Remote indication and tripping, module CM907004 and CM907005												
Vigi NG125	Vigi NG125 add-on residual current device, module CM902008												
Rating (In)	Quality label ⁽¹⁾	Curve			Curve			Curve			Curve		
		B	C	D	B	C	D	B	C	D	B	C	D
10 A		18741	18777	18830	18750	18788	18839	18759	18799	18848	18768	18821	18857
16 A		18742	18778	18831	18751	18789	18840	18760	18800	18849	18769	18822	18858
20 A		18743	18779	18832	18752	18790	18841	18761	18801	18850	18770	18823	18859
25 A		18744	18780	18833	18753	18791	18842	18762	18802	18851	18771	18824	18860
32 A		18745	18781	18834	18754	18792	18843	18763	18803	18852	18772	18825	18861
40 A		18746	18782	18835	18755	18793	18844	18764	18804	18853	18773	18826	18862
50 A		18747	18783	18836	18756	18794	18845	18765	18805	18854	18774	18827	18863
63 A		18748	18784	18837	18757	18795	18846	18766	18806	18855	18775	18828	18864
80 A		18749	18785	18838	18758	18796	18847	18767	18807	18856	18776	18829	18865
Width in 9 mm modules		3			6			9			12		
Accessories		Module CM907004 and CM907006											

(1) Information to be supplied by the country concerned.

(2) Breaking capacity under 1 pole in IT isolated neutral system (case of a double fault).

NG125L circuit breakers (curves B, C, D)

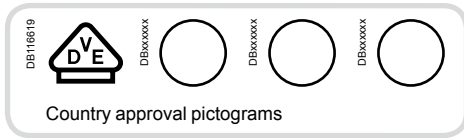

IEC/EN 60947-2

- NG125L circuit breakers are circuit breakers which combine the following functions:
 - circuit protection against short-circuit currents;
 - circuit protection against overload currents;
 - suitability for isolation in the industrial sector to IEC/EN 60947-2;
 - tripping upon fault is indicated by a red mechanical state indicator light on the front face of the circuit breaker.



NG125L 1P



NG125L 2P



NG125L 3P



NG125L 4P

Alternating current (AC) 50/60 Hz									
Breaking capacity (I _{cu}) to IEC/EN 60947-2							Service breaking capacity (I _{cs})		
Ph/Ph (2P, 3P, 4P)	Voltage (U _e)								
	-	-	220 to 240 V	-	380 to 415 V	440 V	500 V		
Ph/N (1P)	110 to 130 V	220 to 240 V	-	380 to 415 V	-	-	-		
Rating (In)	10 to 80 A	100 kA	50 kA	100 kA	12.5 kA ⁽²⁾	50 kA	40 kA	15 kA	75 % of I _{cu}

Direct current (DC)						
Breaking capacity (I _{cu}) according to IEC/EN 60947-2						Service breaking capacity (I _{cs})
Voltage (U _e)						
	12 to 125 V	≤ 144 V	≤ 250 V	≤ 375 V	≤ 500 V	
Number of poles	1P		2P	3P	4P	
Rating (In)	10 to 80 A	50 kA	36 kA	36 kA	36 kA	100 % of I _{cu}

Catalogue numbers

NG125L circuit breaker													
Type	1P			2P			3P			4P			
Auxiliaries	Remote indication and tripping, module CM907004 and CM907005												
Vigi NG125	Vigi NG125 add-on residual current device, module CM902008												
Rating (In)	Quality label ⁽¹⁾	Curve			Curve			Curve			Curve		
		B	C	D	B	C	D	B	C	D	B	C	D
10 A		18741	18777	18830	18750	18788	18839	18759	18799	18848	18768	18810	18857
16 A		18742	18778	18831	18751	18789	18840	18760	18800	18849	18769	18811	18858
20 A		18743	18779	18832	18752	18790	18841	18761	18801	18850	18770	18812	18859
25 A		18744	18780	18833	18753	18791	18842	18762	18802	18851	18771	18813	18860
32 A		18745	18781	18834	18754	18792	18843	18763	18803	18852	18772	18814	18861
40 A		18746	18782	18835	18755	18793	18844	18764	18804	18853	18773	18815	18862
50 A		18747	18783	18836	18756	18794	18845	18765	18805	18854	18774	18816	18863
63 A		18748	18784	18837	18757	18795	18846	18766	18806	18855	18775	18817	18864
80 A		18749	18785	18838	18758	18796	18847	18767	18807	18856	18776	18818	18865
Width in 9 mm modules		3			6			9			12		
Accessories	Module CM907004 and CM907006												

(1) Information to be supplied by the country concerned.

(2) Breaking capacity under 1 pole in IT isolated neutral system (case of a double fault).

NG125L circuit breakers (curves B, C, D) (cont.)

Weight (g)

Circuit breaker	
Type	NG125L
1P	240
2P	480
3P	720
4P	960

Dimensions (mm)

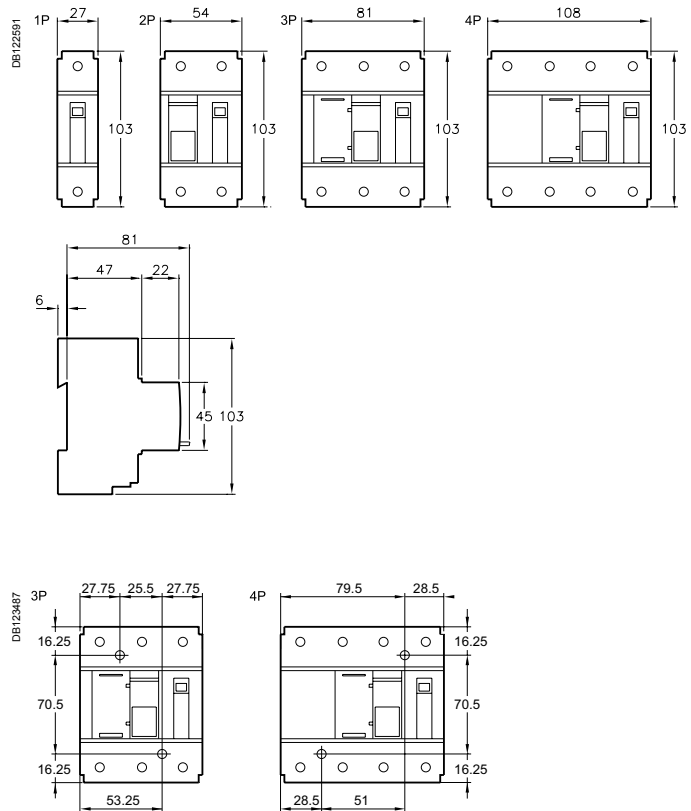

Spacing for mounting on panel

Protection Circuit protection

NG125L circuit breakers (curves B, C, D) (cont.)

06591BN_SE-90

- 3P, 4P 80 A**
- Voltage taps:
 - auxiliaries power supply
 - measurement
 - emergency stop
 - remote reporting



- Cable strength:
 - ribbed cage
 - terminal depth
 - tightening by Allen hex key (NG125 80 A)

- 1P, 2P**
- Padlocking in position: O or I, manual control is inhibited, tripping is enabled

- Test button to check satisfactory operation of the tripping mechanism



- Pull-out strength
 - metallic lock



- 3P, 4P**
- Integrated padlocking device

- Impact and vibration resistance:
 - high-strength enclosure
 - IK 05

- Circuit breaker tripped indicator

- Central manual control, 3 positions:
 - ON
 - tripped on fault
 - open

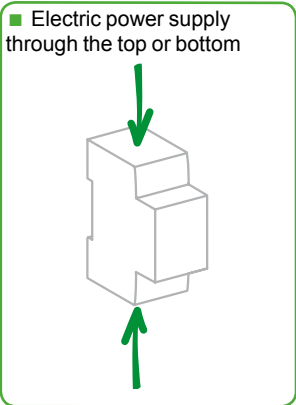

DB123493

- Positive contact indication:
 - suitability for isolation in the industrial sector to IEC/EN 60947-2
 - the presence of the green strip guarantees that the contacts open physically and allows work to be carried out safely on the downstream circuit

- Longer product service life due to:
 - good overvoltage withstand capacity,
 - high limitation performances,
 - fast closure independent of the speed of actuation of the toggle.

C60H-DC, C curve

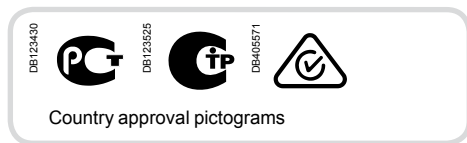

IEC 60947-2

The C60H-DC supplementary protectors are used in direct current circuits (Industrial control and automations, transport, renewable energy...). They combine the following functions of circuit protection against short-circuit and overload currents, control and isolation.

Direct current (DC)						
Breaking capacity (Icu) according to IEC 60947-2						Rated service breaking capacity (Ics)
Type	110 V	220 V	250 V	440 V	500 V	
1P						
Rating 0.5 to 63 A (In)	20 kA	10 kA	6 kA	-	-	75 % Icu
2P (in series)	110 V	220 V	250 V	440 V	500 V	
0.5 to 63 A	-	20 kA	20 kA	10 kA	6 kA	75 % Icu

Catalogue numbers

C60H-DC		
Type	1P	2P
	<p>DB116688</p> <p>Supply from above or below, observing the polarity</p>	<p>DB124110</p> <p>Supply from above</p> <p>DB124111</p> <p>Supply from below</p>
Auxiliaries	Remote signalisation and tripping, module CA907008	
Rating (In)	Curve C	Curve C
0.5 A	A9N61500	A9N61520
1 A	A9N61501	A9N61521
2 A	A9N61502	A9N61522
3 A	A9N61503	A9N61523
4 A	A9N61504	A9N61524
5 A	A9N61505	A9N61525
6 A	A9N61506	A9N61526
10 A	A9N61508	A9N61528
13 A	A9N61509	A9N61529
15 A	A9N61510	A9N61530
16 A	A9N61511	A9N61531
20 A	A9N61512	A9N61532
25 A	A9N61513	A9N61533
30 A	A9N61514	A9N61534
32 A	A9N61515	A9N61535
40 A	A9N61517	A9N61537
50 A	A9N61518	A9N61538
63 A	A9N61519	A9N61539
Number of modules of 9 mm	2	4
Accessories	Modules CA907013 and CA907012	

C60H-DC (cont.), C curve

Connection

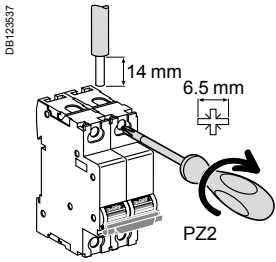

Rating	Tightening torque	Without accessory		With accessories			
		Copper cables		50 mm ² Al terminal	Screw-on connection for ring terminal	Multi-cables terminal	
		Rigid / Stranded	Flexible or with ferrule		Rigid cables	Flexible cables	
≤ 25 A	2.5 N.m	DBI122045 1 to 25 mm ²	DBI122046 1 to 16 mm ²	DBI122035 - 50 mm ²	DBI118789 Ø 5 mm	DBI118787 - 3 x 16 mm ²	- 3 x 10 mm ²
> 25 A	3.5 N.m	1 to 35 mm ²	1 to 25 mm ²				

Multi-cables connection

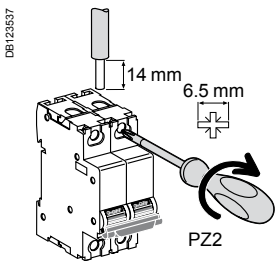

Rating	Tightening torque	Without accessory			
		2 Copper cables		3 Multi-cables / Different wires	
		Rigid / Stranded	Flexible or with ferrule	Flexible / Stranded	Flexible / Stranded / Rigid
≤ 25 A	2.5 N.m	DBI122045 2 x 1 mm ² to 2 x 10 mm ²	DBI122046 2 x 1 mm ² to 2 x 10 mm ²	DBI118787 3 x 1 mm ²	2 x 2.5 mm ² + 1 x 1.5 mm ²
> 25 A	3.5 N.m	2 x 1 mm ² to 2 x 16 mm ²		3 x 4 mm ²	2 x 10 mm ² + 1 x 6 mm ²

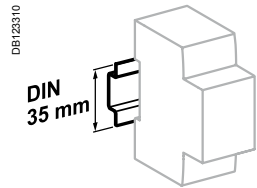

Clip on DIN rail 35 mm.

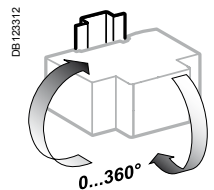

Indifferent position of installation.

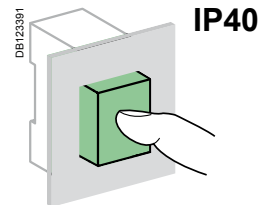

Technical data

- Tripping curves: C curve - Overcurrent protection for any type of application.
- Positive break indication - the green strip indicates that all the poles are open and allows work to be carried out on the downstream circuit in complete safety.
- Suitable for isolation as defined in IEC 60947-2.
- Increase in the service life of the product: thanks to fast closure independent of the speed of action on the handle.
- Current limitation in the event of a fault: fast opening of the contacts prevents the loads from being destroyed in the event of a short-circuit.

Main characteristics

According to IEC 60947-2

Insulation voltage (Ui)	500 V DC
Rated voltage (Un)	1P 250 V DC 2P 500 V DC
Operating voltage (Ue)	1P 24...250 V DC 2P 24...500 V DC
Pollution degree	3
Rated impulse withstand voltage (Uimp) under frame	6 kV
Magnetic tripping (Ii)	8.5 In (± 20 %) (compatible with curve C)

Additional characteristics

Degree of protection (IEC 60529)	Device in modular enclosure	IP40
Utilization category		A (no delay in accordance with IEC 60947-2 standards)
Endurance (O-C)	Electrical	3,000 cycles (where L/R=2 ms) 6,000 cycles where the circuit is resistive
	Mechanical	20,000 cycles
Tropicalization (IEC 60068-2)		Treatment 2 (relative humidity 95 % at 55°C)
Operating temperature		-25°C to 70°C
Storage temperature		-40°C to 85°C



Failure to match polarity during connection may lead to a fire hazard and/or serious injury.

- The connection polarity must be observed (marked on the front panel).
- Use only with direct current.

C60H-DC (cont.), C curve

Weight (g)

Circuit-breaker	
Type	C60H-DC
1P	128 g
2P	256 g

Dimensions (mm)

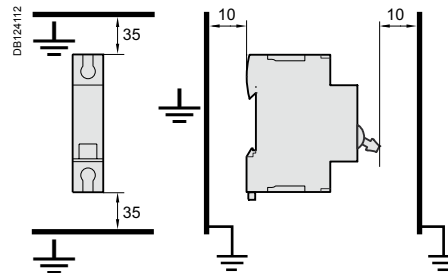
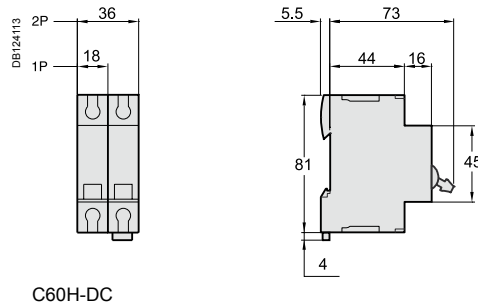

Details of minimum distance between circuit-breaker and earthed metal parts for circuit-breaker intended for use without enclosure.

DC circuit supplementary protectors for photovoltaic installations

C60PV-DC

PB109403-50



The C60PV-DC is a DC circuit breaker dedicated to multi string photovoltaic installations.

This circuit breaker is designed to protect the cables located between each string of photovoltaic modules and the photovoltaic inverter against overloads and short circuits (see application diagram).

Combined with a switch (of the C60NA-DC type, for example), the C60PV-DC will be installed in a string PV protection enclosure at the end of each string of photovoltaic modules.

It can be locked (by a padlocking device) in OFF position as a safety measure for removal of the PV inverter.

Since a fault current can flow in the reverse direction to the operating current, the C60PV-DC can detect and protect against any bidirectional current.

To ensure the safety of the installation, it is necessary, depending on the various types of application, to combine the C60PV-DC with:

- a residual current device at the AC end,
- a fault passage detector (insulation monitoring device) at the DC end
- an earth protection circuit breaker at the DC end (see Practical Advice CA908035).

In all cases, fast action on site will be required to clear the fault (protection not ensured in the event of a double fault).

C60PV-DC is not polarity sensitive: (+) and (-) wires can be inverted without any risk.

The C60PV-DC is delivered with three inter-pole barriers to provide increased isolation distance between two adjacent connectors.

IEC / EN 60947-2



DB404840



Main characteristics

Operating voltage (Ue)	800 V DC
Rated insulation voltage (Ui)	1,000 V DC
Breaking capacity (Icu)	1.5 kA
Impulse voltage (Uimp)	6 kV
Electrical connection	By the bottom for In and Out
Number of poles	2P
Number of modules of 9 mm	8

Diagrams

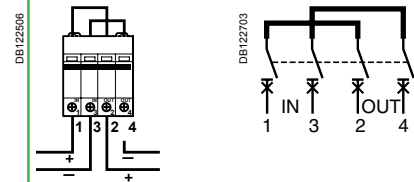

Standards	IEC 60947-2 EN 60947-2
------------------	---------------------------

Rating (A)	Catalogue numbers	
	Curve B	Curve C
1	-	A9N61653
2	-	A9N61654
3	-	A9N61655
5	-	A9N61656
8	A9N61657	-
10	A9N61650	-
13	A9N61658	-
15	A9N61659	-
16	A9N61651	-
20	A9N61652	-
25	A9N61660	-
Auxiliaries	See modules CA907008 and CA907013	

DC circuit supplementary protectors for photovoltaic installations

C60PV-DC (cont.)

Application diagram

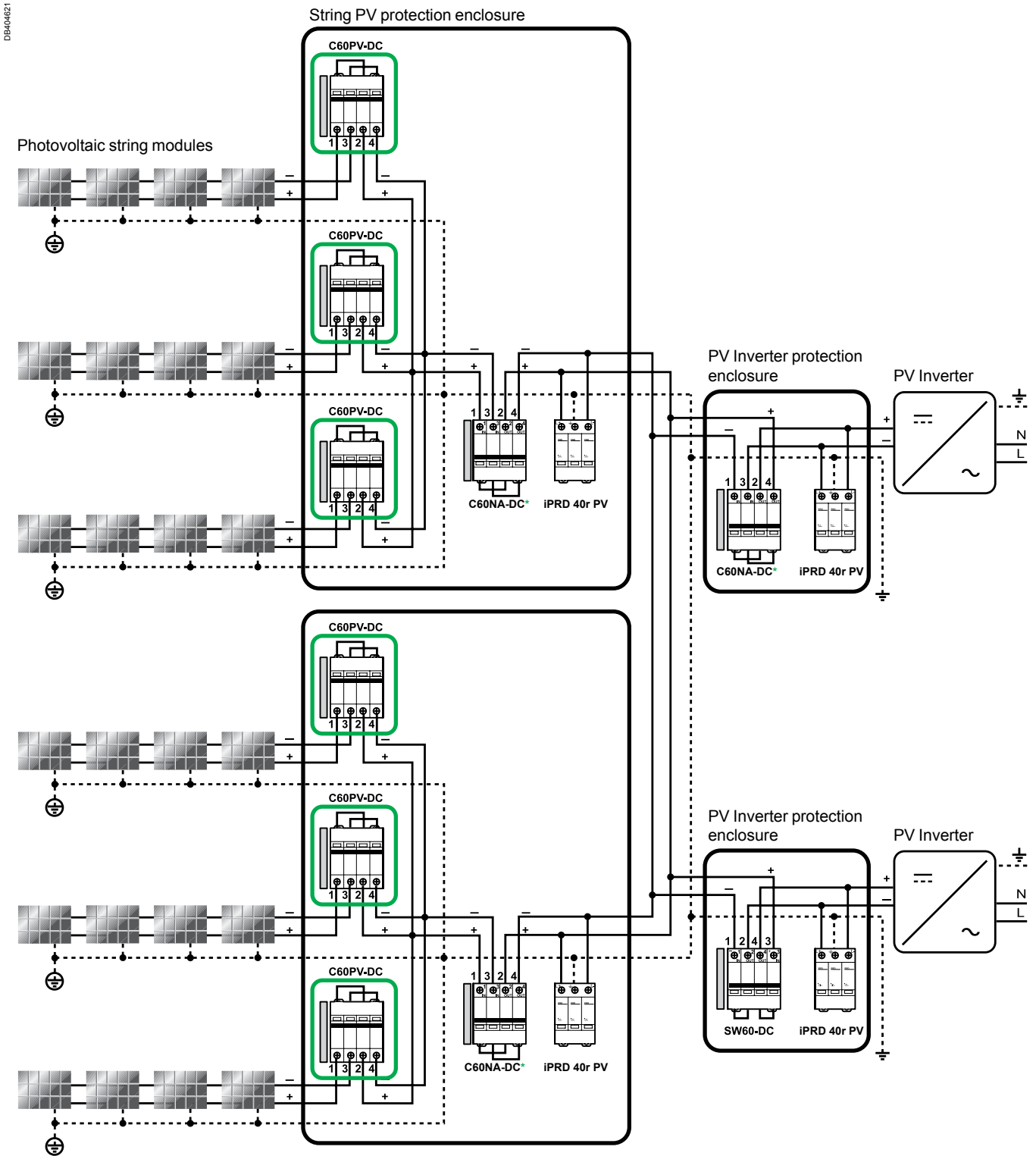

DB404621

MN, MX, MNx, MN \square , MX+OF, OF, SD, OF+SD/OF, OF+SD24

*C60NA-DC:
20 A/1000 V DC or
32 A/800 V DC or
50 A/700 V DC

DC circuit supplementary protectors for photovoltaic installations C60PV-DC (cont.)

Technical data

- Position contact indication - suitability for isolation according to IEC/EN 60947-2 standard.
- The presence of the green strip guarantees physical opening of the contacts and allows operations to be performed on the downstream circuit in complete safety.
- Increased product service life thanks to fast closing independent of the speed of actuation of the toggle.
- Pre-wired product: Input / Output on the same side.

Main characteristics

Rated service breaking capacity (Ics)		100 % of the Icu
Magnetic tripping (Ii)	Ratings 1...5 A	8.5 In (± 20 %) (compatible with curve C)
	Ratings 8...25 A	5.7 In (± 20 %) (compatible with curve B)
Endurance (O-C)	Electrical	1,500 cycles (where L/R=2 ms)
	Mechanical	20,000 cycles
Mechanical		20,000 cycles
Degree of pollution		2
Category		A (no delay in accordance with IEC / EN 60947-2 standards)
Degree of protection (IEC 60529)	Device in modular enclosure	IP40
Tropicalisation		Relative humidity: 95 % at 55°C in accordance with IEC 60068-2 and GB 14048.2 standards
Temperature	Operating	-25°C to 70 °C
	Storage	-40°C to 85°C

Additional characteristics

Rating (A)	Voltage drop (mV)	Impedance (mΩ)	Power loss (W)
1	9200	9200	9.2
2	5104	2552	10.2
3	2980	993.3	8.9
5	2000	400	10
8	1384	173	11.1
10	680	68	6.8
13	572	44	7.4
15	600	40	9
16	648	40.5	10.4
20	588	29.4	11.8
25	488	19.5	12.2

Derating table (A)

C60PV-DC Rating	Ambient temperature (°C)																				
	-30	-25	-20	-15	-10	-5	0	+5	+10	+15	+20	+25	+30	+35	+40	+45	+50	+55	+60	+65	+70
1 A	1.18	1.17	1.15	1.14	1.12	1.1	1.09	1.07	1.05	1.04	1.02	1	0.98	0.96	0.94	0.92	0.9	0.88	0.86	0.84	0.82
2 A	2.54	2.5	2.45	2.41	2.36	2.31	2.26	2.21	2.16	2.11	2.06	2	1.94	1.88	1.82	1.76	1.7	1.63	1.56	1.48	1.41
3 A	3.78	3.71	3.65	3.58	3.51	3.45	3.38	3.3	3.23	3.16	3.08	3	2.92	2.84	2.75	2.66	2.57	2.48	2.38	2.27	2.17
5 A	6	5.92	5.83	5.74	5.66	5.57	5.48	5.39	5.29	5.2	5.1	5	4.9	4.8	4.69	4.58	4.47	4.36	4.24	4.12	4
8 A	9.64	9.5	9.36	9.22	9.08	8.93	8.78	8.63	8.48	8.32	8.16	8	7.83	7.67	7.49	7.31	7.13	6.95	6.76	6.56	6.36
10 A	12.6	12.4	12.2	11.9	11.7	11.5	11.2	11	10.8	10.5	10.3	10	9.7	9.4	9.2	8.9	8.6	8.2	7.9	7.6	7.2
13 A	15.5	15.3	15.1	14.8	14.6	14.4	14.2	14	13.7	13.5	13.2	13	12.7	12.5	12.2	12	11.7	11.4	11.1	10.8	10.5
15 A	18.6	18.3	18	17.7	17.4	17.1	16.7	16.4	16.1	15.7	15.4	15	14.6	14.3	13.9	13.5	13.0	12.6	12.2	11.7	11.2
16 A	19.4	19.1	18.9	18.6	18.3	18.0	17.6	17.3	17.0	16.7	16.3	16	15.7	15.3	14.9	14.6	14.2	13.8	13.4	13.0	12.5
20 A	24.1	23.7	23.4	23.0	22.7	22.3	21.9	21.6	21.2	20.8	20.4	20	19.6	19.2	18.7	18.3	17.9	17.4	16.9	16.4	15.9
25 A	30.4	29.9	29.5	29.0	28.5	28.1	27.6	27.1	26.6	26.1	25.5	25	24.5	23.9	23.3	22.7	22.1	21.5	20.9	20.2	19.6

DC circuit supplementary protectors for photovoltaic installations C60PV-DC (cont.)

Technical data (cont.)

Moreover it is recommended to use:

- a terminal Screw Shield snaps onto the front of the C60PV-DC protective devices to provide greater insulation of the terminal screws
- a spacer clips 9 mm in each side to provide isolation.

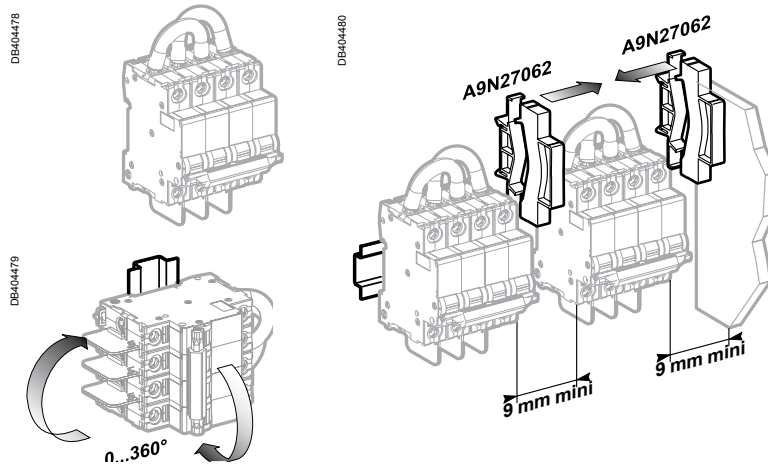

⚠ Required to have a 9 mm space isolation in each side"

Weight (g)

Circuit breaker	
Type	C60PV-DC
	545

Dimensions (mm)

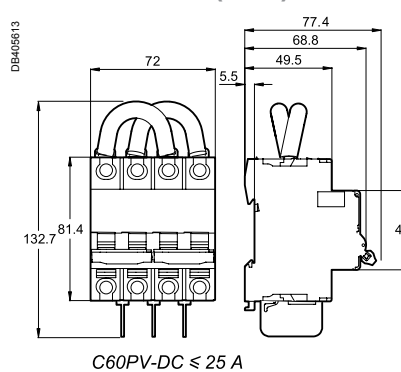

Connection

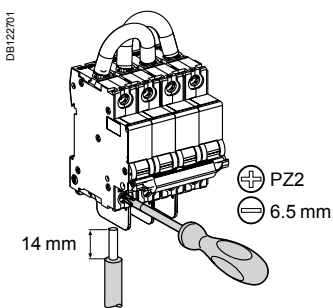

Rating	Tightening torque	Without accessory		With accessories	
		Copper cables UL 486A file no. #E216919		50 mm ² Cu/Al Terminal	Ring tongue terminal screw connection
		Rigids	Flexibles with ferrule		
≤ 25 A	2.5 N.m	DB112804 	DB112805 	DB118725 	DB118726
		1 to 25 mm ²	1 to 16 mm ²	50 mm ²	Ø 5 mm

DC main switch for photovoltaic installations

C60NA-DC

PB108404-50



The C60NA-DC is a direct current switch-disconnector dedicated to disconnection of the string of photovoltaic modules and the PV inverter.

It is designed to isolate the string of photovoltaic modules and the inverter from the rest of the photovoltaic installation for maintenance operations in complete safety.

Combined with a circuit breaker (of the C60PV-DC type, for example), the C60NA-DC will be installed in a string PV protection enclosure close to the strings of photovoltaic modules. It can also be installed near the PV inverter.

It can be locked (by a padlocking device) in OFF position to ensure safety during maintenance operations.

Since a fault current can flow in the reverse direction to the normal operating current, the C60NA-DC can switch a multi-directional current.

C60NA-DC is not polarity sensitive: (+) and (-) wires can be inverted without any risk.

The C60NA-DC is delivered with three inter-pole barriers to provide increased isolation distance between two adjacent connectors.

IEC / EN 60947-3



DB404541



Main characteristics	
Operating voltage (Ue)	20 A: 1000 V CC
	32 A: 800 V CC
	50 A: 700 V CC
Rated insulation voltage (Ui)	1,000 V DC
Rated operational current (Ie)	50 A
Impulse voltage (Uimp)	6 kV
Permissible rated short-time withstand current (Icw)	600 A
Rated short-circuit closing current (Icm)	1 kA
Electrical connection	By the top for In and Out
Number of poles	2P
Number of modules of 9 mm	8
Diagrams	
Standards	IEC 60947-3 EN 60947-3
Catalogue number	A9N61690
Auxiliaries	See modules CA907008 and CA907013

Additional characteristics			
Rating (A)	Voltage drop (mV)	Impedance (mΩ)	Power loss (W)
20 A	100	5.02	2
32 A	151	5.02	5.14
50 A	251	5.02	12.55

DC main switch for photovoltaic installations

C60NA-DC (cont.)

Application diagram

DB404622

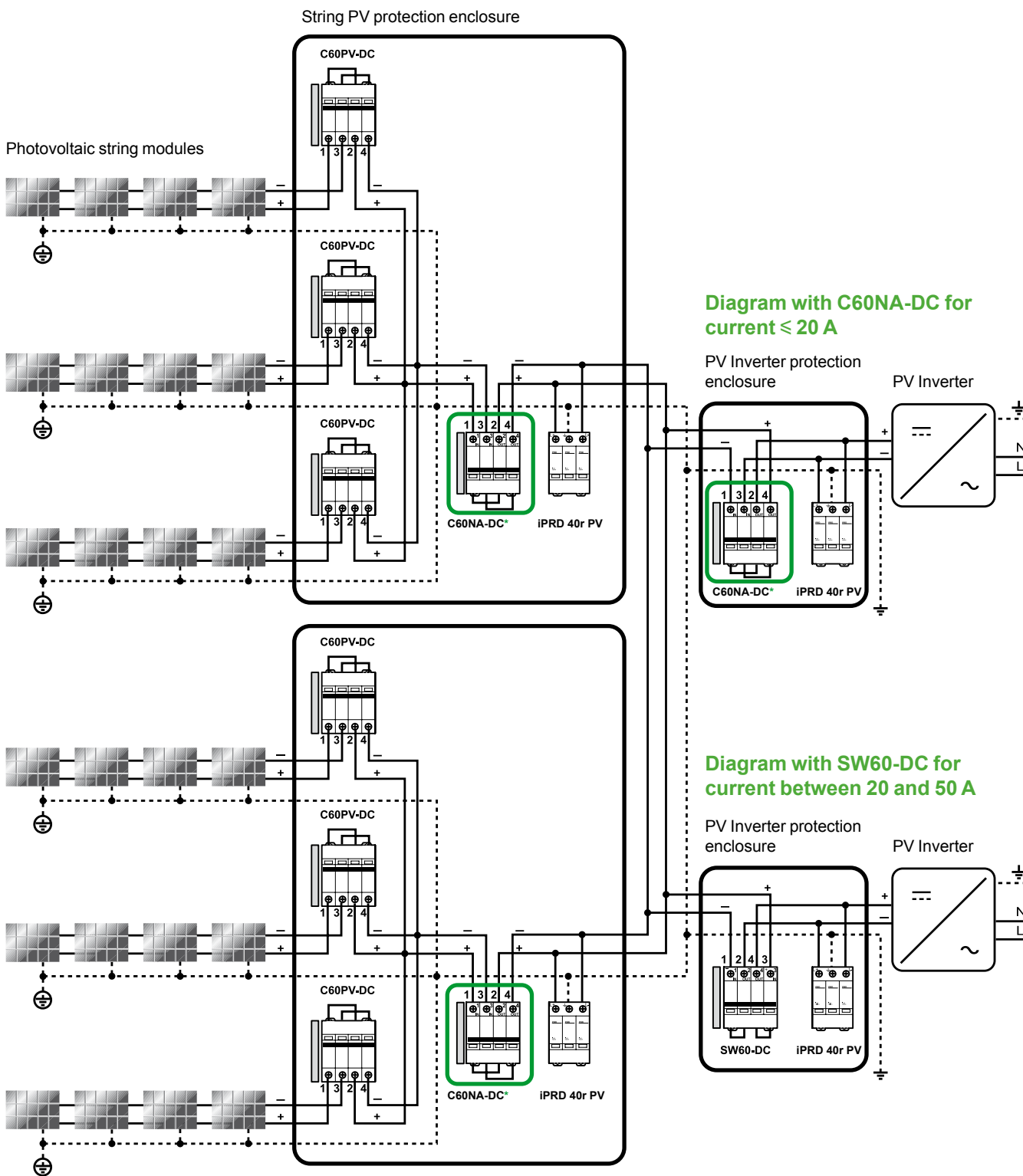

Diagram with C60NA-DC for current ≤ 20 A

Diagram with SW60-DC for current between 20 and 50 A

*C60NA-DC:
20 A/1000 V DC or
32 A/800 V DC or
50 A/700 V DC

MN, MX, MNx, MN \square , MX+OF,
OF, SD, OF+SD/OF, OF+SD24

DC main switch for photovoltaic installations

C60NA-DC (cont.)

Technical data

- Position contact indication - suitability for isolation according to IEC/EN 60947-3 standard.
- The presence of the green strip guarantees physical opening of the contacts and allows operations to be performed on the downstream circuit in complete safety.
- Increased product service life thanks to fast closing independent of the speed of actuation of the toggle.
- Pre-wired product: Input / Output on the same side.

Endurance (O-C)	Electrical	300 cycles
	Mechanical	20,000 cycles
Degree of pollution		2
Category		DC21B
Degree of protection (IEC 60529)	Device in modular enclosure	IP40
Tropicalisation		Relative humidity: 95 % at 55°C in accordance with IEC 60068-2 and GB 14048.2 standards
Temperature	Operating	-25°C to 70°C
	Storage	-40°C to 85°C

C60NA-DC	Ambient temperature (°C)											
Rating	+5	+10	+15	+20	+25	+30	+35	+40	+45	+50	+60	+70
50 A	63	61	60	58	56	54	52	50	48	46	41	35

Moreover it is recommended to use:

- a terminal Screw Shield snaps onto the front of the C60NA-DC protective devices to provide greater insulation of the terminal screws
- a Spacer clips 9 mm in each side to provide isolation.

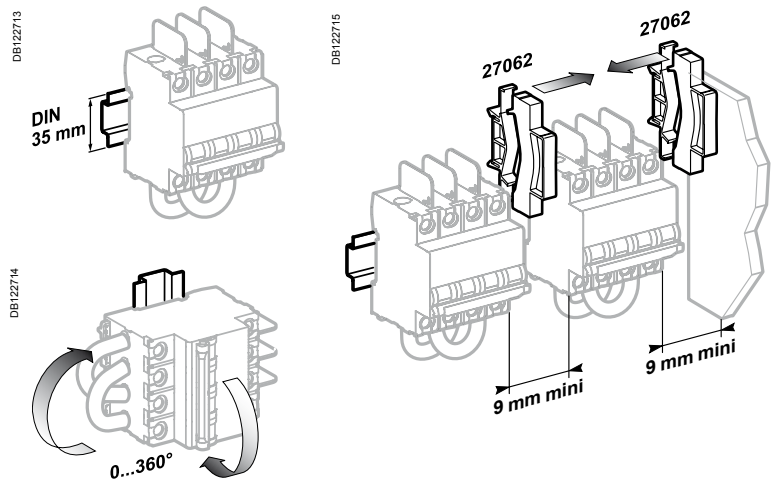

⚠ Required to have a 9 mm space isolation in each side"

DC main switch for photovoltaic installations C60NA-DC (cont.)

Technical data (cont.)

Weight (g)

Switch disconnecter	
Type	C60NA-DC
	530

Dimensions (mm)

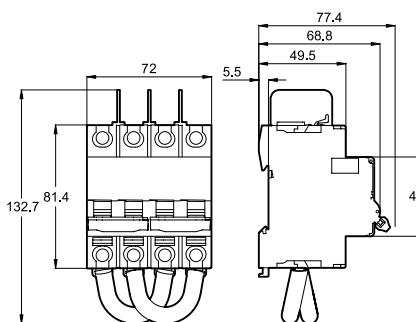

C60NA-DC

Connection

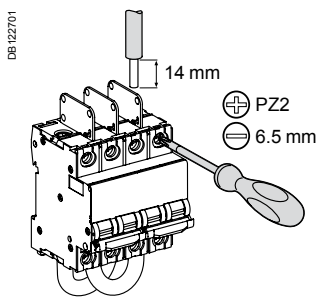

Rating	Tightening torque	Without accessory		With accessories				
		Copper cables UL 486A file no. #E216919		50 mm ² Cu/Al Terminal	Screw on connection for ring terminal	Multi-cables terminal		
		Rigids	Flexibles with ferrule			Rigid cables	Flexible cables	
50 A	3.5 N.m	DB112804 	DB112805 	DB118755 	DB118756 	DB118757 	3 x 16 mm ²	3 x 10 mm ²

DC main switch for photovoltaic installations

Switch SW60-DC

PB109406-50



The SW60-DC is a direct current switch-disconnector dedicated to disconnection of the string of photovoltaic modules and the PV inverter.

It is designed to isolate the inverter from the rest of the photovoltaic installation for maintenance operations in complete safety.

Combined with a circuit breaker (of the C60PV-DC type, for example) and a switch (of the C60NA-DC type, for example), the SW60-DC will be installed in the string PV protection enclosure close to the PV inverter (see application diagram).

It can be locked (by a padlocking device) in OFF position to ensure safety when removing the PV inverter.

SW60-DC is polarity sensitive: (+) and (-) has to be respected for connection.

The SW60-DC is delivered with three inter-pole barrier to provide increased isolation distance between two adjacent connectors.

IEC / EN 60947-3



DB9404842

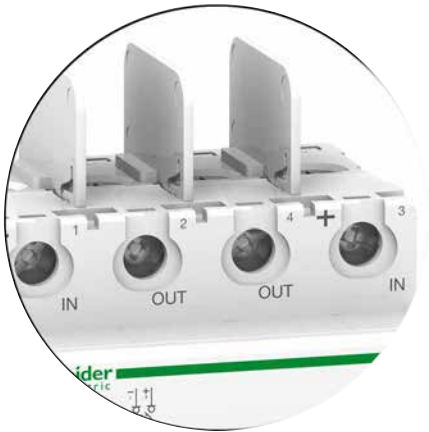

General technical data

Operating voltage (Ue)	1000 V DC
Rated insulation voltage (Ui)	1000 V DC
Rated operational current (Ie)	50 A
Impulse voltage (Uimp)	6 kV
Permissible rated short-time withstand current (Icw)	600 A
Rated short-circuit closing current (Icm)	1 kA
Electrical connection	By the top for In and Out
Number of poles	2P
Number of modules of 9 mm	8
Diagrams	
Standards	IEC 60947-3 EN 60947-3
Catalogue number	A9N61699

DC main switch for photovoltaic installations

Switch SW60-DC (cont.)

Applications

DE404639

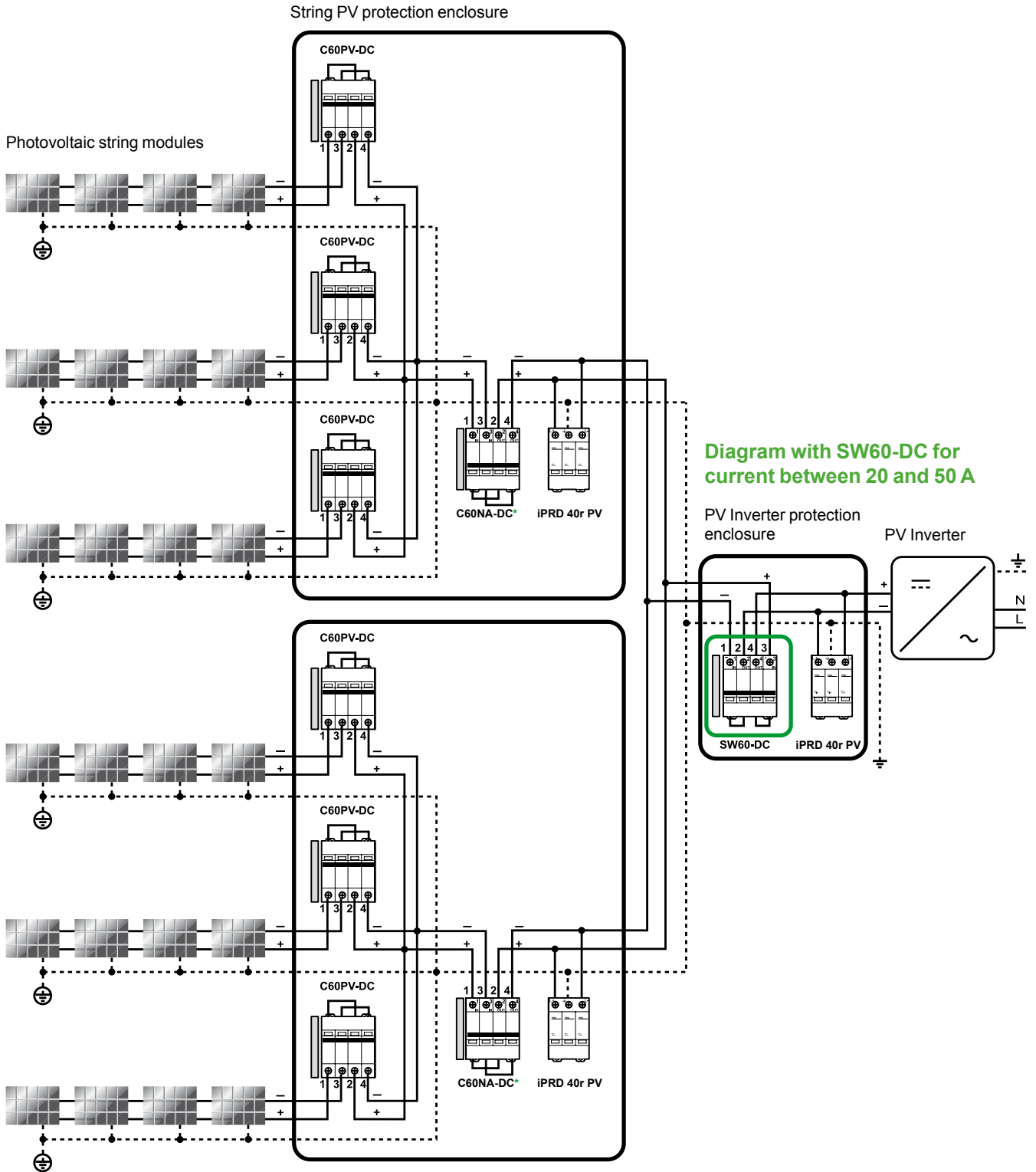

Diagram with SW60-DC for current between 20 and 50 A

*C60NA-DC:
20 A/1000 V DC or
32 A/800 V DC or
50 A/700 V DC

MN, MX, MNx, MN \square , MX+OF,
OF, SD, OF+SD/OF, OF+SD24

DC main switch for photovoltaic installations

Switch SW60-DC (cont.)

Technical data

- Position contact indication - suitability for isolation according to IEC/EN 60947-3 standard.
- The presence of the green strip guarantees physical opening of the contacts and allows operations to be performed on the downstream circuit in complete safety.
- Increased product service life thanks to fast closing independent of the speed of actuation of the toggle.
- Pre-wired product: Input / Output on the same side.

Main characteristics

Endurance (O-C)	Electrical	1,500 cycles
	Mechanical	20,000 cycles
Degree of pollution		2
Category		DC21A
Degree of protection (IEC 60529)	Device in modular enclosure	IP40
Tropicalisation		Relative humidity: 95 % at 55°C in accordance with IEC 60068-2 and GB 14048.2 standards
Temperature	Operating	-25°C to 70°C
	Storage	-40°C to 85°C
	Rating adjustment	40°C

Additional characteristics

Rating (A)	Voltage drop (mV)	Impedance (mΩ)	Power loss (W)
50 A	251	5.02	12.54

Derating table (A)

SW60PV-DC	Ambient temperature (°C)											
Rating	+5	+10	+15	+20	+25	+30	+35	+40	+45	+50	+60	+70
50 A	63	61	60	58	56	54	52	50	48	46	41	35

Moreover it is recommended to use:

- a terminal Screw Shield snaps onto the front of the SW60-DC protective devices to provide greater insulation of the terminal screws.
- a Spacer clips 9 mm in each side to provide isolation.

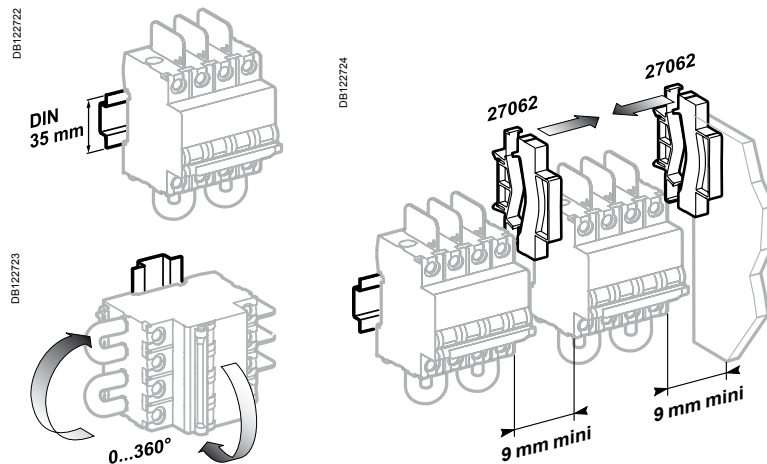

⚠ 9 mm spacers must be used on both sides of the device to create a local ventilation space around the product.

⚠ Failure to match polarity during connection may lead to a fire hazard and/or serious injury. The connection polarity must be observed (marked on the front panel). Use only with direct current.

DC main switch for photovoltaic installations

Switch SW60-DC (cont.)

Technical data (cont.)

Weight (g)

Switch disconnecter	
Type	SW60-DC
	530

Dimensions (mm)

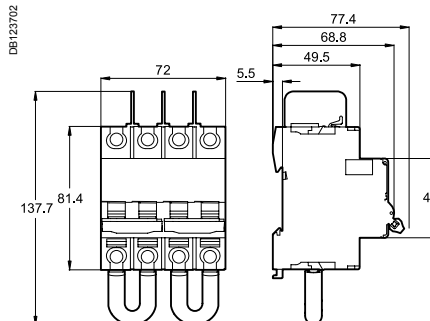

SW60-DC

Connection

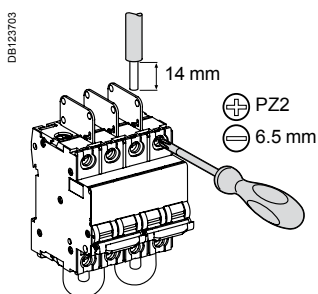

Rating	Tightening torque	Without accessory		With accessories			
		Copper cables UL 486A file no. #E216919		50 mm ² Cu/Al Terminal	screw on connection for ring terminal	Multi-cables terminal	
		Rigids	Flexibles with ferrule			Rigid cables	Flexible cables
50 A	3.5 N.m	 DE112804	 DE112805	 DE119755	 DE119756	 DE119757	 DE119757
		1 to 35 mm ²	1 to 25 mm ²	50 mm ²	Ø 5 mm	3 x 16 mm ²	3 x 10 mm ²

Protection / Motor protection

iC60L circuit breakers instantaneous circuit breakers (ICB) (curve MA)

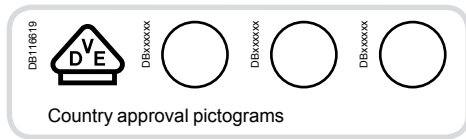

IEC/EN 60947-2



- iC60L curve MA circuit breakers combine the following functions:
 - circuit protection against short-circuit currents,
 - suitability for industrial isolation according to IEC/EN 60947-2, standard,
 - fault tripping indication by a red mechanical indicator in circuit breaker front face,
 - to be associated with overload protection for motor.

Alternating current (AC) 50/60 Hz					
Breaking capacity (Icu) according to IEC/EN 60947-2				Service breaking capacity (Ics)	
Ph/Ph (2P, 3P)	Voltage (Ue)				
Rating (In)	1.6 to 16 A	220 to 240 V	380 to 415 V	440 V	50 % of Icu
	25 à 40 A	30 kA	15 kA	10 kA	50 % of Icu

Catalogue numbers

iC60L instantaneous trip circuit breaker		
Type	2P	3P
Auxiliaries	Remote tripping and indication, module CA907000 and CA907002	Remote tripping and indication, module CA907000 and CA907002
Vigi iC60	Vigi iC60 add-on residual current device, module CA902005	Vigi iC60 add-on residual current device, module CA902005
Rating (In)	Curve MA	Curve MA
Quality label (1)		
1.6 A	A9F90272	A9F90372
2.5 A	A9F90273	A9F90373
4 A	A9F90204	A9F90304
6.3 A	A9F90276	A9F90376
10 A	A9F90210	A9F90310
12.5 A	A9F90282	A9F90382
16 A	A9F90216	A9F90316
25 A	A9F90225	A9F90325
40 A	A9F90240	A9F90340
Width in 9-mm modules	4	6
Accessories	Module CA907000 and CA907001	Module CA907000 and CA907001

(1) Information to be provided by the country.

Protection / Motor protection

iC60L circuit breakers instantaneous circuit breakers (ICB) (curve MA) (cont.)

PB10434-40

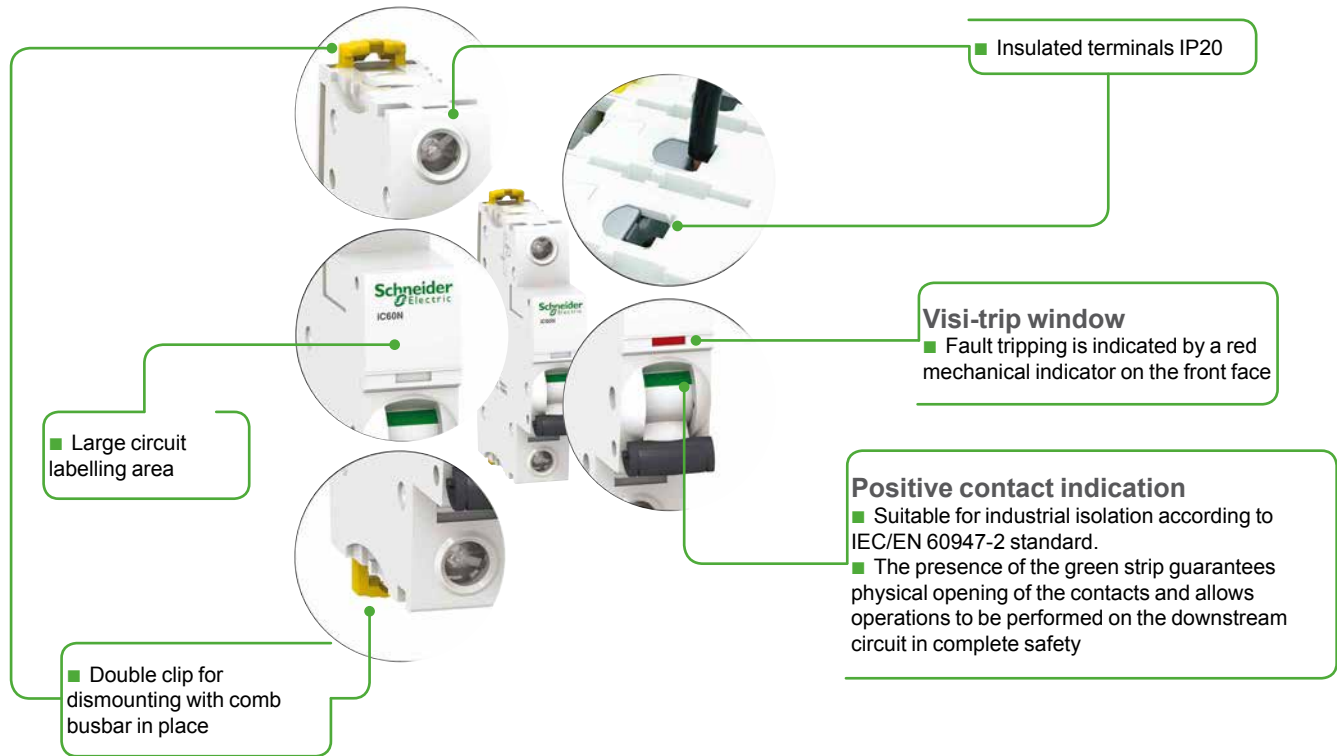

- Increased product service life thanks to:
 - overvoltage resistance by high level of industrial performances conception (pollution degree, rated impulse withstand voltage and insulation voltage),
 - high performance limitation (see limitation curves),
 - fast closing independent of the speed of actuation of the toggle.
- Remote indication, open/closed/tripped, by optional auxiliary contacts.
- Top or bottom electrical feeding.

Protection / Motor protection

iC60L circuit breakers instantaneous circuit breakers (ICB) (curve MA) (cont.)

Connection

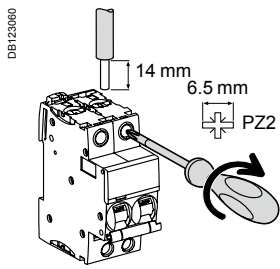

Rating	Tightening torque	Without accessory		With accessories		
		Rigid	Flexible or with ferrule	50 mm ² Al terminal	Screw-on connection for ring terminal	Multi-cables terminal
1.6 to 16 A	2 N.m	DBI122945	DBI122946	DBI122935	DBI187789	DBI187787
25 to 40 A	3.5 N.m	1 to 25 mm ²	1 to 16 mm ²	-	∅ 5 mm	-
		1 to 35 mm ²	1 to 25 mm ²	50 mm ²		3 x 16 mm ²
						3 x 10 mm ²

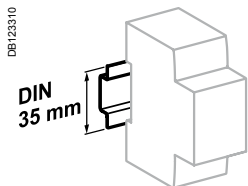

Clip on DIN rail 35 mm.

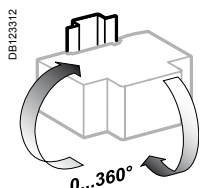

Indifferent position of installation.

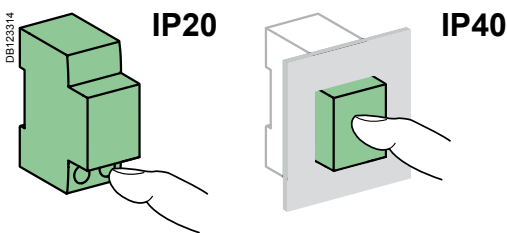

Technical data

Main characteristics		
According to IEC/EN 60947-2		
Insulation voltage (Ui)		500 V AC
Pollution degree		3
Rated impulse withstand voltage (Uimp)		6 kV
Thermal tripping	Reference temperature	50 °C
	Temperature derating	See module CA908007
Magnetic tripping	MA curve	12 In ± 20 %
Utilization category		A
Additional characteristics		
Degree of protection (IEC 60529)	Device only	IP20
	Device in modular enclosure	IP40
Endurance (O-C)	Electrical	10,000 cycles
	Mechanical	20,000 cycles
Overvoltage category (IEC 60364)		IV
Operating temperature		-35°C to +70°C
Storage temperature		-40°C to +85°C
Tropicalization (IEC 60068-1)		Treatment 2 (relative humidity 95 % to 55°C)

Weight (g)

Circuit-breaker	
Type	iC60L
2P	250
3P	375

Dimensions (mm)

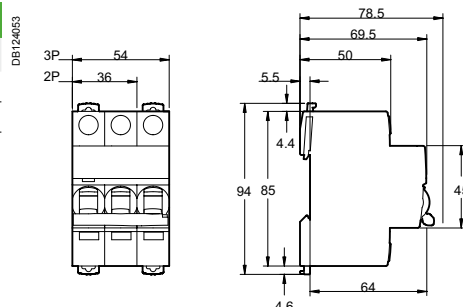

NG125LMA circuit breakers (curve MA)

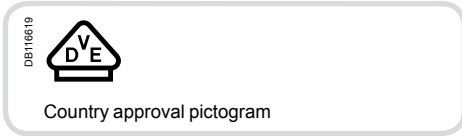

IEC/EN 60947-2

- NG125LMA circuit breakers combine the following functions:
 - circuit protection against short-circuit currents,
 - suitability for industrial isolation according to IEC/EN 60947-2, standard,
 - fault tripping indication by a red mechanical indicator in circuit breaker front face,
 - they must be associated with overload protection for motor.



NG125LMA 2P



NG125LMA 3P

Alternating current (AC) 50/60 Hz					
Breaking capacity (Icu) to IEC/EN 60947-2					
Ph/Ph (2P, 3P)	Voltage (Ue)				Service breaking capacity (Ics)
	220 to 240 V	380 to 415 V	440 V	500 V	
Rating (In) 4 to 80 A (trip units)	100 kA	50 kA	40 kA	15 kA	75 % of Icu

Catalogue numbers

NG125LMA circuit breaker					
Type	2P		3P		
Auxiliaries	Remote indication and tripping, module CM907004 and CM907005				
Vigi NG125	Vigi NG125 add-on residual current device, module CM902008				
Rating (In)	Quality label ⁽¹⁾	Magn. I (A)	Curve MA	Curve MA	
4 A		50	18868	18879	
6.3 A		75	18869	18880	
10 A		120	18870	18881	
12.5 A		150	18871	18882	
16 A		190	18872	18883	
25 A		300	18873	18884	
40 A		480	18874	18885	
63 A		750	18875	18886	
80 A		960	18876	18887	
Width in 9 mm modules			6	9	
Accessories			Module CM907004 and CM907006		

(1) Information to be supplied by the country concerned.

NG125LMA circuit breakers (curve MA) (cont.)

Connection

DB122861

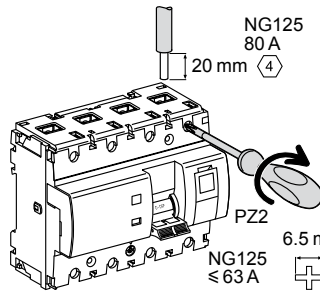

Rating	Tightening torque	Without accessories		With accessories					
		Copper cables		70 mm ² Al terminal	Screw-on connection for ring terminal	Small ring terminal	Multi-cable terminal		
		Rigid	Flexible or with ferrule	Rigid single cables			Rigid cables	Flexible cables	
4 to 63 A	3.5 N.m	DB122845	DB122846	DB123410	DB123488	DB118768	DB118767	3 x 16 mm ²	3 x 10 mm ²
2P 80 A	6 N.m								
3P 80 A									

■ On 3P 80 A: upstream voltage taps for each pole, by 6.35 mm Fast-on terminal.

DB123310

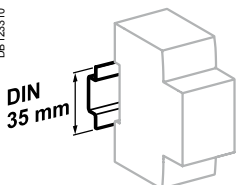

Clips on to 35 mm DIN rail.

DB123314

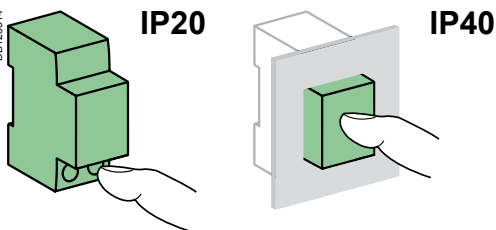

Technical data

Main characteristics

According to IEC/EN 60947-2

Insulation voltage (U _i)	690 V AC	
Degree of pollution	3	
Rated impulse withstand voltage (U _{imp})	8 kV	
Thermal tripping	Reference temperature	40°C
Magnetic tripping (I _n)	MA curve	12 I _n ± 20 %
Utilization category		A

Additional characteristics

Degree of protection (IEC 60529)	Device only	IP20
	Device in modular enclosure	IP40
Endurance (O-C)	Electrical	10,000 cycles
	Mechanical	20,000 cycles
Operating temperature		-30°C to +70°C
Storage temperature		-40°C to +70°C
Tropicalization (IEC 60068-1)		Treatment 2 (relative humidity of 95 % at 55°C)

NG125LMA circuit breakers (curve MA) (cont.)

Weight (g)

Circuit breaker	
Type	NG125LMA
2P	480
3P	720

Dimensions (mm)

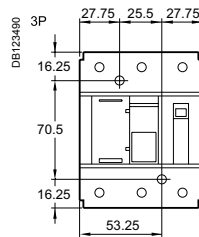
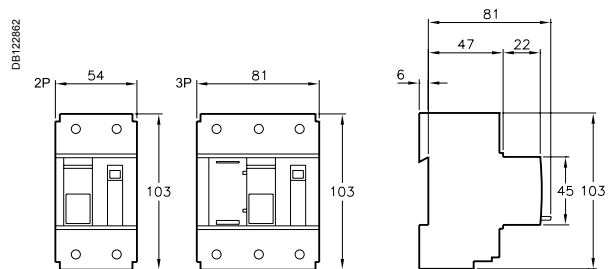

Spacing for mounting on panel

Protection Motor protection

NG125LMA circuit breakers (curve MA) (cont.)

056918N_SE-90

DB123483



- Cable strength:
 - ribbed cage
 - terminal depth
 - tightening by Allen hex key (NG125 80 A)

- 3P 80 A**
- Voltage taps:
 - auxiliaries power supply
 - measurement
 - emergency stop
 - remote reporting

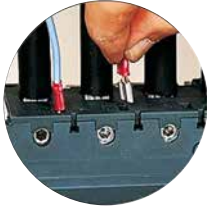

- Padlocking in position: O or I, manual control is inhibited, tripping is enabled

- Test button to check satisfactory operation of the tripping mechanism



- 3P**
- Pull-out strength:
 - metallic lock

- 3P**
- Integrated padlocking device

- Impact and vibration resistance:
 - high-strength enclosure
 - IK 05

- Circuit breaker tripped indicator

- Central manual control, 3 positions:
 - ON
 - tripped on fault
 - open

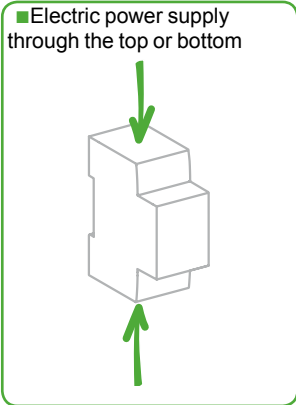

- Positive contact indication:
 - suitability for isolation in the industrial sector to IEC/EN 60947-2
 - the presence of the green strip guarantees that the contacts open physically and allows work to be carried out safely on the downstream circuit

- Longer product service life due to:
 - good overvoltage withstand capacity,
 - high limitation performances,
 - fast closure independent of the speed of actuation of the toggle.

Circuit protection

Tertiary sector, Industry

D0 fuse disconnectors switches

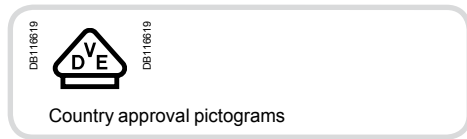

IEC/EN 60947-1, IEC/EN 60947-3, IEC 60269-1, IEC 60269-3, VDE 0660-100, VDE 0660-107



- The plug-in fuse switches disconnectors D01 and the switches disconnectors fuse D02 provide protection against overloads and short circuits.
- They are used for service sector and industrial applications.
- Depending on the versions, they should be provided with D01 or D02 type cartridges.

Accessories

- The D02 gauges allow you to limit the rating of the fuses, depending on the model used, from 20 A to 50 A.

Catalogue numbers

Fuse disconnectors switches										
Type	1P		1P+N		2P		3P		3P+N	
	D01	D01	D01	D02	D02	D01	D02	D01	D02	
	DB405042 1 2	DB405043 1 N 2 N	DB405438 1 N 2 N	DB405044 1 3 2 4	DB405045 1 3 5 2 4 6	DB405439 1 3 5 2 4 6	DB405046 1 3 5 N 2 4 6 N	DB405440 1 3 5 N 2 4 6 N	DB405440 1 3 5 N 2 4 6 N	
D01 fuse switches disconnectors										
Rating (In)										
10 A	-	MGN01610	-	-	-	-	-	MGN01710	-	
13 A	-	MGN01613	-	-	-	-	-	MGN01713	-	
16 A	-	MGN01616	-	-	MGN01316	-	-	MGN01716	-	
Width in 9 mm modules	-	4	-	-	6	-	-	8	-	
D02 switches disconnectors fuse										
Rating (In)										
63 A	MGN02163	MGN02663		MGN02263	MGN02363			MGN02763		
Width in 9 mm modules	3	6		6	9			12		



Accessories for D02 switches disconnectors fuse

Type	Rating	Colour	
Fuse gauge	20 A	Blue	MGN09120
	25 A	Yellow	MGN09125
	32-35-40 A	Black	MGN09135
	50 A	White	MGN09150

D02 : Gauges

- These allow fitting of fuses from 20 A to 50 A

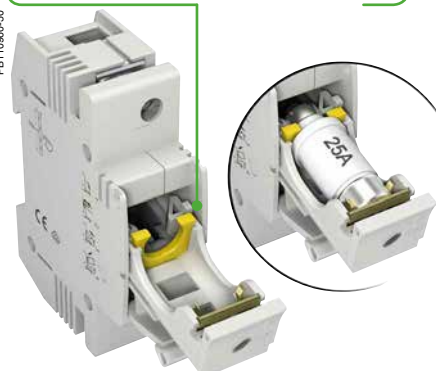

Connection

- Upstream/downstream by tunnel terminals
- For D01: by 18 mm forked comb busbar

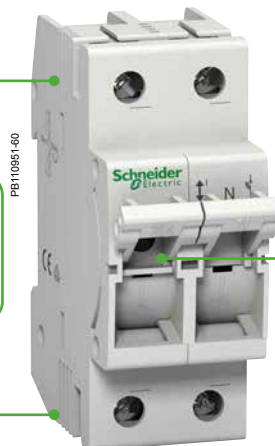

Blown-fuse indicator

D0 fuse disconnectors switches (cont.)

Connection

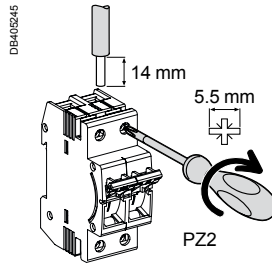

Type	Tightening torque	Copper cables	
		Rigid	Flexible or with ferrule
D01	2 N.m	1.5 to 25 mm ²	1.5 to 16 mm ²
D02	3 N.m	1.5 to 35 mm ²	1.5 to 25 mm ²

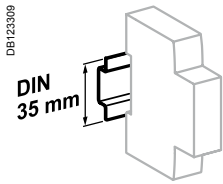

Clip on DIN rail 35 mm.

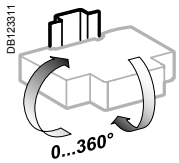

Indifferent position of installation.

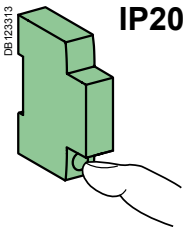

IP20

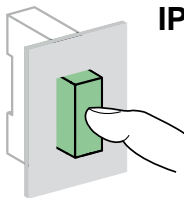

IP40

Technical data

Main characteristics		D01	D02
Operating voltage (Ue)		230/400 V AC	230/400 V AC 110 V DC (2P)
Operating frequency (Hz)		45-62 Hz	45-62 Hz
Service breaking capacity (Isc)		AC 50 kA	50 kA
		DC -	8 kA
Rated insulation voltage (Ui)		400 V	400 V
Rated impulse withstand voltage (Ui)		6000 V	6000 V
Utilization category (IEC 60947-3)		400 V AC AC-22A	AC-22A (63 A) AC-23A (35 A) DC-22B (63 A) DC-22A (63 A)
Endurance (O-C)		Electrical 1500 cycles	1500 cycles
		Mechanical 10,000 cycles	8500 cycles
Additional characteristics			
Degree of protection		Device only IP20	Device in modular enclosure IP40
Operating temperature		-5°C to +40°C	
Storage temperature		-25°C to +55°C	

Dimensions (mm)

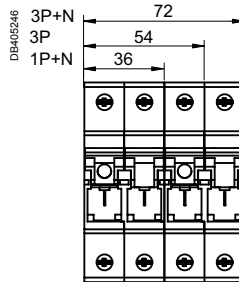

D01 fuse switches disconnectors

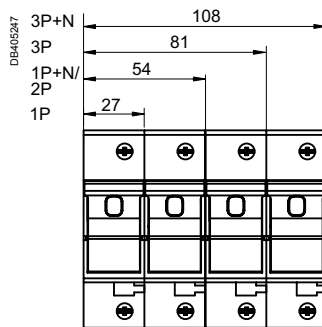
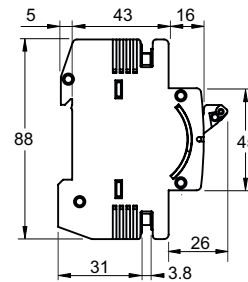

D02 switches disconnectors fuse

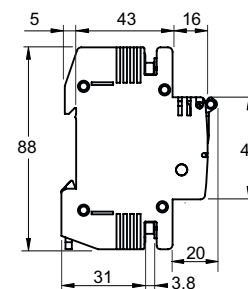

Protection Earth leakage protection

Choice of earth leakage protection devices



Choice of sensitivity

The sensitivity of an earth leakage protection device depends mainly on the function it has to perform:

- Protection from electric shock by direct contact.
- Protection from electric shock by indirect contact.
- Protection from fire due to current leakage.

The following table gives a reminder of:

- The circuits that must be protected against these various risks (obligation or recommendation).
- The type of earth leakage protection device to be used in each case, its sensitivity, and its location in the distribution diagram.

Type of protection	Standard requirements		Additional Schneider Electric recommendations	Sensitivity (IΔn)		
	National standard <i>To be filled in according to the country standard</i>	International standard IEC 60364		30 mA (*)	100 mA to 3000 mA (depending on the earthing system)	300 mA (or 500 mA)
Protection from electric shock by direct contact						
 <small>DB123167</small>	To be filled in according to the country standard	Power supply for <ul style="list-style-type: none"> ■ General-purpose power sockets, up to 20 A ■ Appliances in the vicinity of a bathtub, shower, pond or swimming pool ■ Portable appliances for outdoor use, up to 32 A ■ Lighting To be modified according to national obligations (above)	None	Setup in final distribution switchboard <ul style="list-style-type: none"> ■ Residual current device protecting a circuit ■ Residual current circuit breaker protecting a group of circuits 		
Protection from electric shock by indirect contact						
 <small>DB123168</small>	To be filled in according to the country standard	The entire power distribution system, except for devices: <ul style="list-style-type: none"> ■ With class II insulation ■ Operating at Safety Extra Low Voltage (class III) To be modified according to national obligations (above)	None	If ground continuity is not ensured over the time	Setup in final distribution switchboard <ul style="list-style-type: none"> ■ Residual current circuit breaker or device, on incoming feeder Setup in subdistribution board or main switchboard <ul style="list-style-type: none"> ■ Residual current device protecting a circuit ■ Residual current device or circuit breaker protecting a group of circuits ■ On incoming feeder: residual current circuit breaker or device 	
Protection from fire due to current leakage						
 <small>DB123169</small>	To be filled in according to the country standard	<ul style="list-style-type: none"> ■ High-risk premises: <ul style="list-style-type: none"> □ explosion (BE3) □ fire (BE2) ■ Agricultural and horticultural buildings ■ Equipment for fairs, exhibitions and shows ■ Temporary outdoor recreational installations To be modified according to national obligations (above)	<ul style="list-style-type: none"> ■ Dilapidated buildings or electrical installations ■ Humid atmospheres: agricultural buildings, public swimming pools ■ Presence of chemical agents 		Setup in final distribution switchboard <ul style="list-style-type: none"> ■ Residual current circuit breaker or device, on incoming feeder Setup in subdistribution board or main switchboard <ul style="list-style-type: none"> ■ Residual current device protecting each circuit to a high-risk zone ■ Residual current device or circuit breaker protecting a group of circuits ■ On incoming feeder: residual current circuit breaker or device 	

(*) The 10 mA sensitivity is useful for certain very specific applications, where there is a risk that someone could sustain a non-dangerous current (10 to 30 mA) without being able to get free. Example: healthcare equipment for hospital beds. Generally, devices with this very high sensitivity are liable to cause frequent tripping, due to the natural leakage currents of the installation.

Choice of earth leakage protection devices (cont.)

Interference immunity

Schneider Electric provides various equipment technologies capable of overcoming the consequences of interference of all kinds.

Operating conditions		Examples	Types					
			AC	A	A-SI	F	B	
Loads								
	With no special characteristics	<ul style="list-style-type: none"> General-purpose power sockets Incandescent lighting Household appliances: microwave oven, dishwasher, clothes dryer Electric heating, water heater 	■	■	■	■	■	
	Including a rectifier	Single phase	<ul style="list-style-type: none"> Household appliances: induction cooking appliances, washing machines (variable speed) Single-phase variable speed drives 	-	■	■	■	■
		Three phase	<ul style="list-style-type: none"> Three-phase variable speed industrial drives Three-phase uninterruptible power supplies 	-	-	-	-	■
	Generating high-frequency interference (current peaks, harmonics)		<ul style="list-style-type: none"> Fluorescent lighting powered by extra low voltage transformer, by electronic ballast Variable luminosity lighting Powerful IT equipment Single-phase variable speed industrial drives Air conditioning Telecommunications equipment Capacitor banks 	-	-	■	■	■
	Including an anti-harmonic filter in the power supply		<ul style="list-style-type: none"> Microcomputer systems Computer peripherals (printers, scanners, etc.) 	-	-	■	-	■
Electrical environment								
	Vicinity of equipment generating transient overvoltages	<ul style="list-style-type: none"> High-powered switching devices Reactive energy compensation banks 	-	-	■	■	■	
	Circuits powered by an uninterruptible power supply "Isolated neutral" (IT) earthing system	<ul style="list-style-type: none"> Backed-up networks 	-	-	■	-	■	
	Major risk of lightning strokes	<ul style="list-style-type: none"> Buildings protected by a lightning protection system Mountainous or humid regions Regions with high keraunic level 	-	-	■	■	■	
Atmosphere								
	Ambient temperature which could be less than -5°C		-	■	■	■	■	
	Severe environments whose code varies between AF2 and AF4 according to IEC 60364-5-51	<ul style="list-style-type: none"> Indoor swimming pools Yacht harbours, marinas, camping grounds Water treatment Chemical industries, heavy industries, paper mills Mines and cellars, road tunnels Markets, stock raising, food processing industries 	-	-	■ (1)	-	-	

(1) Atmospheres with high concentrations of chemicals or dust: see tables 1 and 2 in the CA908015E catalog module for description of corrosive atmosphere classes and appropriate additional protection.

Selectivity

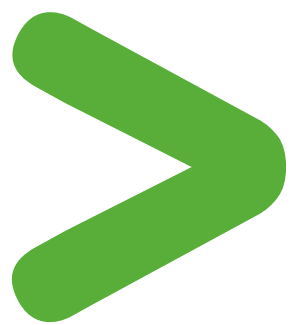

Residual current devices of average sensitivity (100 mA and more) are available in a selective (S) and delayed (R) version. This option ensures that, in the event of an earth fault downstream of the installation, only the defective part is switched off. The table below shows (in green) which upstream/downstream equipment combinations provide this selectivity.

Sensitivity (mA) - Downstream		Sensitivity (mA) - Upstream												
		Instantaneous						Selective S			Delayed R			
		30	100	300	500	1000	3000	100	300	500	1000	3000	1000	3000
	Instantaneous	30	-	-	-	-	-	-	-	-	-	-	-	-
		100	-	-	-	-	-	-	-	-	-	-	-	-
		300	-	-	-	-	-	-	-	-	-	-	-	-
		500	-	-	-	-	-	-	-	-	-	-	-	-
		1000	-	-	-	-	-	-	-	-	-	-	-	-
		3000	-	-	-	-	-	-	-	-	-	-	-	-
	Selective S	100	-	-	-	-	-	-	-	-	-	-	-	
		300	-	-	-	-	-	-	-	-	-	-	-	
		500	-	-	-	-	-	-	-	-	-	-	-	
		1000	-	-	-	-	-	-	-	-	-	-	-	
		3000	-	-	-	-	-	-	-	-	-	-	-	
		3000	-	-	-	-	-	-	-	-	-	-	-	
	Delayed R	1000	-	-	-	-	-	-	-	-	-	-	-	
		3000	-	-	-	-	-	-	-	-	-	-	-	



Overview of the earth leakage protection product range

Selection guide

Type		Residual current circuit breakers			
		iID	RCCB-ID 125 A		RCCB-ID type B
					
Standards		IEC/EN 61008		IEC/EN 61008-1 and VDE 0664	IEC/EN 61008 and VDE 0664
Voltage (V)	Ue	110/230	230/400	230/400	230/400
Number of poles	1P+N	–	–	–	–
	2P	■	■	■	–
	3P	–	–	–	–
	4P	■	■	■	■
Type	AC	–	■	■	–
	A	■	■	■	–
	S/I	–	■	■	–
	B	–	–	–	■
Impulse voltage (kV)	Uimp	6	6	4	4
Insulation voltage (V)	Ui	500	500	400	400
Current rating (A)	In	63	16 to 100	125	25 to 125
Frequency (Hz)		50	50	50	50
Rated breaking capacity (A)	Icn	–	–	–	–
Rated conditional short-circuit current	Icn	10000	10000	10000	10000
Rated residual breaking and making capacity (A)	(IΔm)	1500	1500	1250	10 In (500 A min.)
Sensitivity (mA)	(IΔn)	10	–	■	–
		30	■	■	■
		100	–	■	–
		300	–	■	■
		500	–	■	■
		1000	–	–	–
		3000	–	–	–
		300 \square	–	■	■
		500 \square	–	■	–
		1000 \square	–	–	–
Electrical characteristics					
Curves	B	–	–	–	–
	C	–	–	–	–
	D	–	–	–	–
	L	–	–	–	–
	K	–	–	–	–
		MA	–	–	–
			–	–	–
For more details, see module		CA902002	CM902001	CM902001	CM902002
Accessories		CA907000, CA907001	CM902001	CM902001	CM902002
Auxiliaries		CA907000, CA907002	CM902001	CM902001	CM902002

I_{nc}: rated conditional short-circuit current

Value of the alternating component of the prospective current that a residual current circuit breaker protected by an appropriate short-circuit protective device (SCPD) mounted in series can withstand in specified conditions of use.

I_{Δc}: rated residual short-circuit current

Value of the alternating component of the prospective residual current that a residual current circuit breaker protected by an appropriate short-circuit protective device (SCPD) mounted in series can withstand in specified conditions of use.

I_m: rated making and breaking capacity

Value of the alternating component of the prospective current that a residual current circuit breaker is capable of establishing or interrupting in specified conditions of use.

I_{Δm}: rated making and breaking capacity

Value of the alternating component of the prospective residual current that a residual current circuit breaker is capable of establishing and withstanding during its opening time and interrupting in specified conditions of use and behaviour.

SCPD

Short-circuit protective device (a fuse in the case of our markings): this is the max. fuse that can be used to resist the value $I_{nc} = I_{Δc}$.

Protection Earth leakage protection iID double terminals residual current circuit breakers (A type)

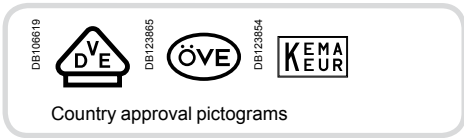

IEC/EN 61008-1

KEMA KEUR approval, only for 2P/4P 25 A to 63 A catalogue numbers.



- The iID double tunnel terminals residual current circuit breakers provide:
 - protection of persons against electric shock by direct contact (≤ 30 mA),
 - protection of persons against electric shock by indirect contact (≥ 100 mA),
 - protection of installations against the risk of fire (300 mA or 500 mA).

Catalogue numbers

iID double terminals residual current circuit breakers													
Type	Product	A iID									Width in 9 mm module		
Auxiliaries		Can accept auxiliaries, module CA907002											
2P		Sensitivity	10 mA	30 mA	30 mA Type G	100 mA	100 mA	100 mA Type G	300 mA	300 mA	500 mA		
	Rating	16 A	A9Z20216	-	-	-	-	-	-	-	-	4	
		25 A	A9Z20225	A9Z21225	-	-	-	-	A9Z24225	-	-		
		40 A	-	A9Z21240	A9Z81240	A9Z22240	-	-	A9Z82240	A9Z24240	A9Z25240		-
		63 A	-	A9Z21263	A9Z81263	A9Z22263	-	-	-	A9Z24263	A9Z25263		-
		80 A	-	A9Z21280	-	A9Z22280	-	-	-	A9Z24280	A9Z25280		-
		100 A	-	A9Z21291	-	A9Z22291	-	-	-	A9Z24291	A9Z25291		-
4P		Sensitivity	10 mA	30 mA	30 mA Type G	100 mA	100 mA	100 mA Type G	300 mA	300 mA	500 mA		
	Rating	25 A	-	A9Z21425	-	-	-	-	A9Z24425	-	A9Z26425	8	
		40 A	-	A9Z21440	-	A9Z22440	-	-	A9Z24440	A9Z25440	A9Z26440		
		63 A	-	A9Z21463	-	A9Z22463	-	-	A9Z24463	A9Z25463	A9Z26463		
		80 A	-	A9Z21480	A9Z81480	A9Z22480	-	-	A9Z24480	A9Z25480	A9Z26480		
		100 A	-	A9Z21491	A9Z81491	A9Z22491	-	-	A9Z82491	A9Z24491	A9Z25491		A9Z26491
4P Type THV		Sensitivity	10 mA	30 mA	30 mA Type G	100 mA	100 mA	100 mA Type G	300 mA	300 mA	500 mA		
	Rating	40 A	-	A9Z81440	A9Z91440	A9Z82440	A9Z83440	A9Z92440	-	-	-	8	
		63 A	-	A9Z81463	A9Z91463	A9Z82463	A9Z83463	A9Z92463	-	-	-		
Voltage rating (Ue)		2P	230 - 240 V										
		4P	400 - 415 V										
Operating frequency		50/60 Hz											
Accessories		Module CA907000 and CA907001											

Protection Earth leakage protection

iID double terminals residual current circuit breakers (SI type)

IEC/EN 61008-1

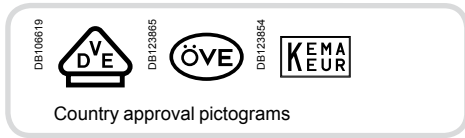

KEMA KEUR approval, only for 2P/4P 25 A to 63 A catalogue numbers.



- The iID double tunnel terminals residual current circuit breakers provide:
 - protection of persons against electric shock by direct contact (≤ 30 mA),
 - protection of persons against electric shock by indirect contact (≥ 100 mA),
 - protection of installations against the risk of fire (300 mA).

The SI type provides increased immunity from electrical interference and polluted or corrosive environments.

Catalogue numbers

iID double terminals residual current circuit breakers								
Type	SI						Width in 9 mm module	
Product	iID							
Auxiliaries	Can accept auxiliaries, module CA907002							
2P 	Sensitivity	10 mA	30 mA	100 mA	100 mA	300 mA	4	
	Rating	25 A	A9Z30225	A9Z31225	-	-		
		40 A	-	A9Z31240	A9Z32240	-		A9Z35240
		63 A	-	A9Z31263	A9Z32263	-		A9Z35263
		80 A	-	A9Z31280	A9Z32280	-		A9Z35280
	100 A	-	A9Z31291	A9Z32291	-	A9Z35291		
4P 	Sensitivity	10 mA	30 mA	100 mA	100 mA	300 mA	8	
	Rating	25 A	-	A9Z31425	-	-		
		40 A	-	A9Z31440	A9Z32440	-		A9Z35440
		63 A	-	A9Z31463	A9Z32463	-		A9Z35463
		80 A	-	A9Z31480	A9Z32480	-		A9Z35480
	100 A	-	A9Z31491	A9Z32491	-	A9Z35491		
4P Type THV 	Sensitivity	10 mA	30 mA	100 mA	100 mA	300 mA	8	
	Rating	40 A	-	-	-	A9Z93440		A9Z95440
	63 A	-	-	-	A9Z93463	A9Z95463		
Voltage rating (Ue)	2P	230 - 240 V						
	4P	400 - 415 V						
Operating frequency	50/60 Hz							
Accessoires	Module CA907000 and CA907001							

Protection

Earth leakage protection

iLD double terminals residual current circuit breakers (A, SI types) (cont.)

Connection between double-terminal protection devices

With comb busbar at the back/cables at the front

Without comb busbar at the back/cables at the front

DB404815



		Back	Front	
Rating	Tightening torque	Comb busbar	Copper cables	
		Thickness of the teeth	Rigid	Flexible or with ferrule
All	3.5 N.m	1.5 mm	1 to 35 mm ²	1 to 25 mm ²

Connection between double-terminal and single-terminal protection devices

Cables at the back/comb busbar at the front

DB404817



		Back	Front	
Rating	Tightening torque	Copper cables		Comb busbar
		Rigid	Flexible or with ferrule	Thickness of the teeth
All	3.5 N.m	1 to 25 mm ²	1 to 16 mm ²	1.5 mm

■ Connection by comb busbar or by cable (according to EN 50027).

Connection

DB123847

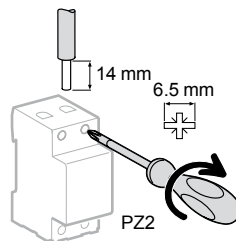

		With accessories		
Rating	50 mm ² AI terminal	Screw-on connection for ring terminal	Multi-cables terminal	
			Rigid cables	Flexible cables
All	50 mm ²	Ø 5 mm	3 x 16 mm ²	3 x 10 mm ²

Protection Earth leakage protection

iID double terminals residual current circuit breakers (A, SI types)

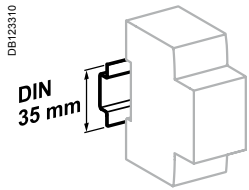

Clip on DIN rail 35 mm.

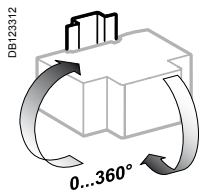

Indifferent position of installation.

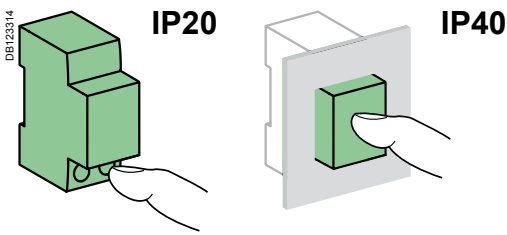

Technical data

Main characteristics			
Insulation voltage (U _i)		500 V	
Pollution degree		3	
Rated impulse withstand voltage (U _{imp})		6 kV	
According to IEC/EN 61008-1			
Making and breaking capacity (I _m /I _{Δm})		1500 A	
Surge current withstand (8/20 μs) without tripping	AC and A types (no selective)	250 Å	
	AC, A types (selective)	3 kÅ	
	SI type	3 kÅ	
Conditional rated short circuit current (I _{nc} /I _{Δc})	With iC60N/H/L	Equal to breaking capacity of iC60	
	With fuse	10,000 A	
Behaviour in case of voltage drop		Residual current protection down to 0 V according to IEC/EN 61008-1 § 3.3.4	
Additional characteristics			
Degree of protection	Device only	IP20	
	Device in modular enclosure	IP40 Insulation class II	
Endurance (O-C)	Electrical (AC1)	16 to 63 A	15,000 cycles
		80 to 100 A	10,000 cycles
	Mechanical		20,000 cycles
Operating temperature	AC type		-5°C to +60°C
	A and SI types		-25°C to +60°C
Storage temperature			-40°C to +85°C

Dimensions (mm)

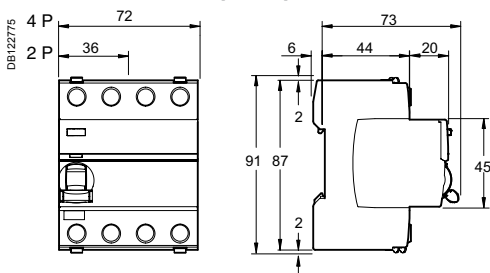

Weight (g)

iID double terminals residual current circuit breakers	
Type	iID
2P	210
4P	370

Protection

Earth leakage protection

ID double terminals residual current circuit breakers (A, SI types) (cont.)

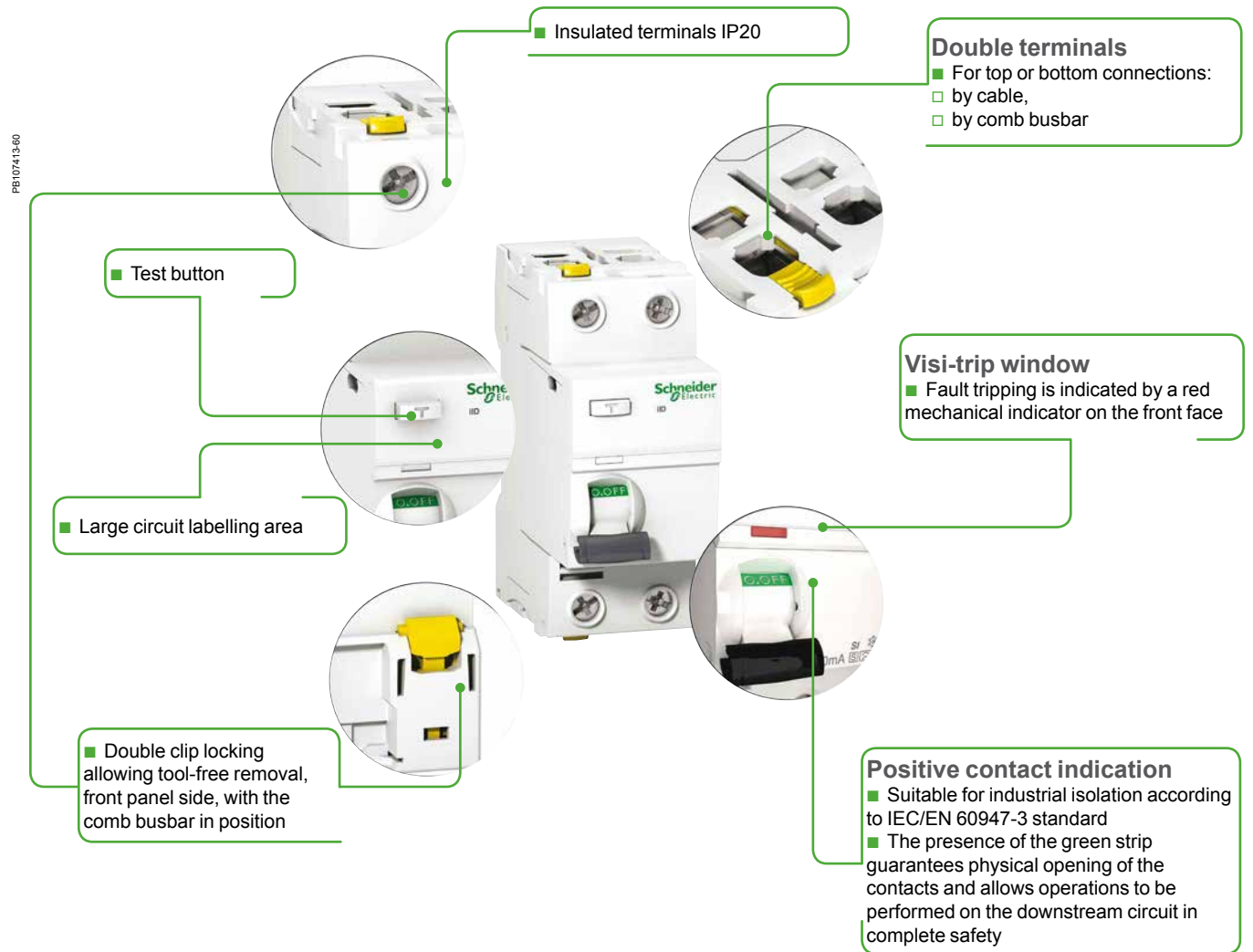

SI type

The SI type provides increased immunity from electrical interference and polluted or corrosive environments.

Protection Earth leakage protection

Acti9 iID B-SI type residual current circuit breakers (RCCB)

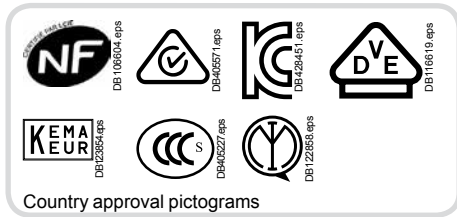

IEC/EN 61008-2-1
IEC/EN 62423
IEC 61543
VDE 0664

As per the above standards:

- The Acti9 iID B-SI type residual current circuit breakers provide:
 - protection of persons against electric shock by direct contact (30 mA),
 - protection of persons against electric shock by indirect contact (≥ 300 mA),
 - protection of installations against the risk of fire (300 mA or 500 mA).

B-SI type

The Acti9 iID B-SI type residual current circuit breakers provide:

- protection in the event of a continuous earth fault current on networks generated by:
 - controllers and variable speed drives,
 - battery chargers and inverters, such as used in photovoltaic application,
 - backed-up power supplies.

■ They include protection against earth fault currents:

- sinusoidal AC residual currents (AC type),
- pulsed DC residual currents (A type),
- multi frequency residual current (F type).

■ The use of Acti9 iID B-SI type residual current circuit breaker can be made mandatory, according to standards applicable in country.

■ For applications using 3-poles drives, such as:

- crane,
- lift,
- HVAC,
- pumping system.

B type is needed.

For more information, see earth leakage protection guide CA908066E.

■ The Acti9 iID B-SI type works optimally with the variable speed drives manufactured by Schneider Electric, even with a long cable length between motor and variable speed drive (up to 50 m).

■ SI technology is embedded in Acti9 iID B-SI type residual current circuit breaker, providing increased immunity from electrical interference and polluted environments.

■ The Acti9 iID B-SI type is compatible with Schneider Electric AC and A types wired in parallel or in series in the installation, following coordination tables (refer to earth leakage protection guide CA908066E).



Catalog numbers

Acti9 iID B-SI type residual current circuit breakers						
Type	B-SI					Width in 9 mm module
2P 	Sensitivity	30 mA	300 mA	300 mA	500 mA	8
	Rating 25 A	A9Z61225	A9Z64225	-	-	
	40 A	A9Z61240	A9Z64240	-	-	
	63 A	A9Z61263	A9Z64263	-	-	
Voltage rating (Ue)		230 V				
Operating frequency		50 Hz				
4P 	Sensitivity	30 mA	300 mA	300 mA	500 mA	8
	Rating 25 A	A9Z61425	A9Z64425	-	-	
	40 A	A9Z61440	A9Z64440	A9Z65440	A9Z66440	
	63 A	A9Z61463	A9Z64463	A9Z65463	A9Z66463	
	80 A	A9Z61480	A9Z64480	A9Z65480	A9Z66480	
Voltage rating (Ue)		400 V				
Operating frequency		50 Hz				

Protection Earth leakage protection

Acti9 iID B type EV residual current circuit breakers (RCCB) for Electric Vehicle

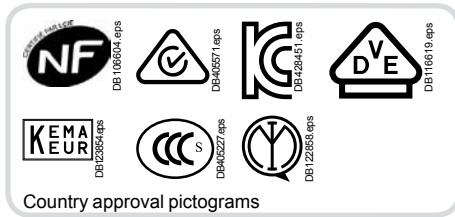

IEC/EN 61008-2-1
IEC/EN 62423
IEC 61543
VDE 0664

As per the above standards:

- The Acti9 iID B type EV residual current circuit breakers provide:
 - protection of persons against electric shock by direct contact (30 mA),
 - protection of persons against electric shock by indirect contact,
 - protection of installations against the risk of fire.

B type

The Acti9 iID B type EV residual current circuit breakers provide:

- protection in the event of a continuous earth fault current on networks generated by electric car charging station.

- The use of Acti9 iID B type EV residual current circuit breaker can be made mandatory, according to standards applicable in country.

- The Acti9 iID B type EV is compatible with Schneider Electric AC and A types wired in parallel or in series in the installation, following coordination tables (refer to earth leakage protection guide CA908066E).



Catalog numbers

Acti9 iID B type EV residual current circuit breakers			
Type		B	Width in 9 mm module
2P 	Sensitivity	30 mA	8
	Rating 16 A	A9Z51216	
	25 A	A9Z51225	
	40 A	A9Z51240	
Voltage rating (Ue)		230 V	
Operating frequency		50 Hz	
4P 	Sensitivity	30 mA	8
	Rating 40 A	A9Z51440	
	63 A	A9Z51463	
	Voltage rating (Ue)		
Operating frequency		50 Hz	

Protection

Earth leakage protection

Acti9 iID B-SI type residual current circuit breakers (RCCB)



A9261225-40.eps



A9261425-40.eps



PE104488-14.eps

IEC/EN 61008-2-1

IEC/EN 62423

IEC 61543

VDE 0664

As per the above standards:

- The Acti9 iID B-SI type residual current circuit breakers provide:
 - protection of persons against electric shock by direct contact (30 mA),
 - protection of persons against electric shock by indirect contact (≥ 300 mA),
 - protection of installations against the risk of fire (300 mA or 500 mA).

B-SI type

The Acti9 iID B-SI type residual current circuit breakers provide:

- protection in the event of a continuous earth fault current on networks generated by:
 - controllers and variable speed drives,
 - battery chargers and inverters, such as used in photovoltaic application,
 - backed-up power supplies.
- They include protection against earth fault currents:
 - sinusoidal AC residual currents (AC type),
 - pulsed DC residual currents (A type),
 - multi frequency residual current (F type).

■ The use of Acti9 iID B-SI type residual current circuit breaker can be made mandatory, according to standards applicable in country.

- For applications using 3-poles drives, such as:
 - crane,
 - lift,
 - HVAC,
 - pumping system.

B type is needed.

For more information, see earth leakage protection guide CA908066E.

■ The Acti9 iID B-SI type works optimally with the variable speed drives manufactured by Schneider Electric, even with a long cable length between motor and variable speed drive (up to 50 m).

■ **SI** technology is embedded in Acti9 iID B-SI type residual current circuit breaker, providing increased immunity from electrical interference and polluted environments.

■ The Acti9 iID B-SI type is compatible with Schneider Electric AC and A types wired in parallel or in series in the installation, following coordination tables (refer to earth leakage protection guide CA908066E).

Accessories

- 4P sealable screw shield.

Protection
Earth leakage protection

Acti9 iID B-SI type residual current circuit breakers (RCCB) (cont.)

Catalog numbers

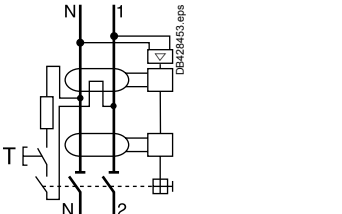
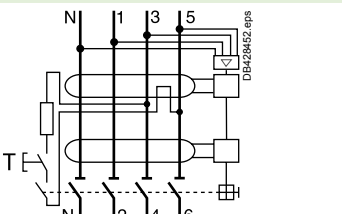
Acti9 iID B-SI type residual current circuit breakers							
Type	B-SI 				Width in 9 mm module		
2P 	Rating	25 A	A9Z61225	A9Z64225	-	-	8
		40 A	A9Z61240	A9Z64240	-	-	
		63 A	A9Z61263	A9Z64263	-	-	
Voltage rating (Ue)			230 V				
Operating frequency			50 Hz				
4P 	Rating	25 A	A9Z61425	A9Z64425	-	-	8
		40 A	A9Z61440	A9Z64440	A9Z65440	A9Z66440	
		63 A	A9Z61463	A9Z64463	A9Z65463	A9Z66463	
		80 A	A9Z61480	A9Z64480	A9Z65480	A9Z66480	
Voltage rating (Ue)			400 V				
Operating frequency			50 Hz				

(*) Supplied with screw shield accessory.

Accessory		
Type	Number of pole	Ref. no.
Screw shield (set of 20) for upstream or downstream	4P	A9A26981

Protection Earth leakage protection

Acti9 iID B type EV residual current circuit breakers (RCCB) for Electric Vehicle



IEC/EN 61008-2-1
IEC/EN 62423
IEC 61543
VDE 0664

As per the above standards:

- The Acti9 iID B type EV residual current circuit breakers provide:
 - protection of persons against electric shock by direct contact (30 mA),
 - protection of persons against electric shock by indirect contact,
 - protection of installations against the risk of fire.



B type 

The Acti9 iID B type EV residual current circuit breakers provide:

- protection in the event of a continuous earth fault current on networks generated by:
 - electric car charging station.

■ The use of Acti9 iID B type EV residual current circuit breaker can be made mandatory, according to standards applicable in country.

■ The Acti9 iID B type EV is compatible with Schneider Electric AC and A types wired in parallel or in series in the installation, following coordination tables (refer to earth leakage protection guide CA908066E).



Accessories

- 4P sealable screw shield.

Catalog numbers

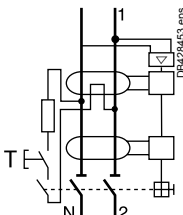
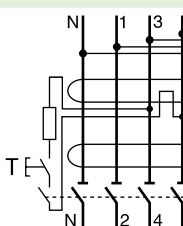
Acti9 iID B type EV residual current circuit breakers			
Type		B 	Width in 9 mm module
2P 	Sensitivity	30 mA	
	Rating	16 A	A9Z51216
		25 A	A9Z51225
		40 A	A9Z52225* A9Z51240
Voltage rating (Ue)		230 V	
Operating frequency		50 Hz	
4P 	Sensitivity	30 mA	
	Rating	40 A	A9Z51440
		63 A	A9Z51463
Voltage rating (Ue)		400 V	
Operating frequency		50 Hz	

(*) Supplied with screw shield accessory.

Accessory		
Type	Number of pole	Ref. no.
Screw shield (set of 20) for upstream or downstream	4P	A9A26981

Protection Earth leakage protection

Acti9 iID B type EV and Acti9 iID B-SI type residual current circuit breakers (RCCB)

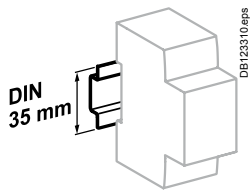

Clip on DIN rail 35 mm.

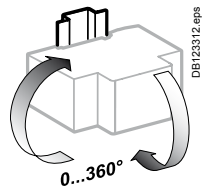

Indifferent position of installation.

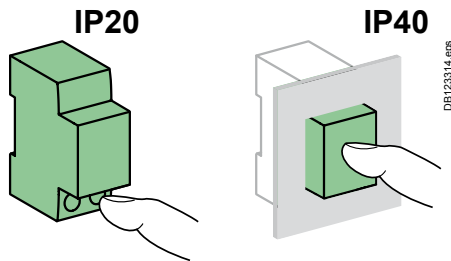

Technical data

Electrical characteristics		
Insulation voltage (U _i)	2P	250 V
	4P	500 V
Pollution degree	3	
Rated impulse withstand voltage (U _{imp})	6 kV	
According to IEC/EN 61008-2-1		
Making and breaking capacity (I _m /I _{Δm})	1500 A	
Surge current withstand (8/20 μs) without tripping	No selective <input type="checkbox"/>	3 kA
	Selective <input type="checkbox"/>	5 kA
Conditional rated short circuit current (I _{nc} /I _{Δc})	With 100 A gG fuse	10,000 A
Additional characteristics		
Degree of protection (IEC 60529)	Device only	IP20
	Device in modular enclosure	IP40 Insulation class II
Endurance (O-C)	Electrical	≤ 63 A: 15,000 cycles > 63 A: 10,000 cycles
	Mechanical	20,000 cycles
Range of test button operating voltage	30 mA	2P: 180...270 V AC 4P: 300...450 V AC
	300, 500 mA	2P: 140...330 V AC 4P: 220...450 V AC
Impulse withstand according to IEC 60068-2-27	15 g	
Vibration withstand according to IEC 60068-2-6	3 g	
Electromagnetic compatibility	According to IEC 61543	
Operating temperature	-25°C to +60°C	
Storage temperature	-40°C to +85°C	
Dissipated power	Module CA908009	

Dielectric test

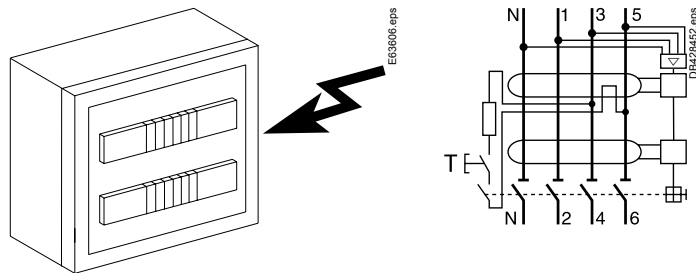

⚠ To perform the dielectric test, disconnect terminals:
 4P: 1, 3, 5 and 2, 4, 6
 2P: 1 and 2

Weight (g)

Residual current circuit breakers	
Type	iID
2P	350
4P	415

Dimensions (mm)

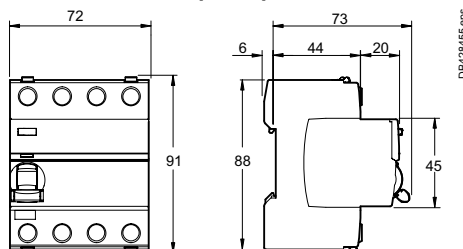

Protection Earth leakage protection

Acti9 iID B type EV and Acti9 iID B-SI type residual current circuit breakers (RCCB) (cont.)

Connection

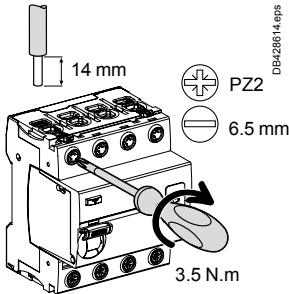

Rating	Without accessory				With accessories			
	Back		Front		50 mm ² AI terminal	Screw-on connection for ring terminal	Multi-cables terminal	
	Rigid	Flexible or with ferrule	Rigid	Flexible or with ferrule			Rigid cables	Flexible cables
All	DB122945.eps 1 to 25 mm ²	DB122946.eps 1 to 16 mm ²	DB122945.eps 1 to 35 mm ²	DB122946.eps 1 to 25 mm ²	DB122935.eps 50 mm ²	DB118789.eps Ø 5 mm	DB118787.eps 3 x 16 mm ²	3 x 10 mm ²

Accessories: modules CA907000 and CA907001

- Insulated terminals IP20**
 - DB428584.eps
 - DB428595.eps
- Double terminals**
 - For top or bottom connections:
 - by cable,
 - by comb busbar
- Double clip locking** allowing tool-free removal, front panel side, with the comb busbar in position
- Test button**
 - DB428598.eps
- Large circuit labelling area**
- Voltage presence LED**
 - For an optimal use of the LED, Acti9 iID must be power supplied by top connections
 - Led indication (powered by top connections):
 - On: powered and ready
 - Off: not powered
- DB428597.eps**
- VISI-TRIP window**
 - Fault tripping is indicated by a red mechanical indicator on the front face
- DB428240.eps**
- VISI-SAFE window**
 - Positive contact indication**
 - A green strip on the toggle indicates full opening of all the poles
 - Padlocking possible

Protection, Earth leakage protection

Acti9 iID40 residual current circuit breakers bottom connection

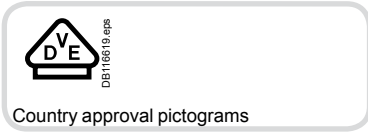

CEI/EN 61008-2-1

As per the above standard:

■ The residual current circuit breakers offer the following earth leakage protection functions:

- protection of persons against electric shock by direct contact (30 mA),
- protection of persons against electric shock by indirect contact (300 mA),
- protection of installations against the risk of fire (300 mA)

A-SI type

The A-SI type provides increased immunity from electrical interference and polluted or corrosive environments.

Catalog numbers

Acti9 iID40 residual current circuit breakers						
Type		A	A-SI	Width in 9-mm modules		
Electrical auxiliaries, Remote control		Catalog modules CA907002 and CA904010				
1P+N	Sensitivity	30 mA	30 mA	300 mA		
	Rating 25 A	A9R43625	A9R83625	-	4	
	40 A	A9R43640	A9R83640	-		
	63 A	-	-	-		
	Rating 25 A	A9R43725	A9R83725	-	8	
	40 A	A9R43740	A9R83740	-		
	63 A	A9R43763	A9R83763	A9R93763		
Voltage rating (Ue)	1P+N	230 - 240 V AC				
	3P+N	400 - 415 V AC				
Operating frequency	50/60 Hz					
Accessories	Catalog modules CA907001 and CA907015					
Comb busbars	Catalog module CA907026					
PowerTag energy sensors	Catalog modules CA907029 and CA908058					

Protection, Earth leakage protection

Acti9 iID40 residual current circuit breakers bottom connection

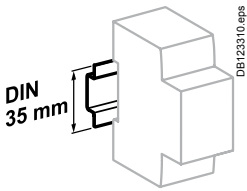

Clip on DIN rail 35 mm.

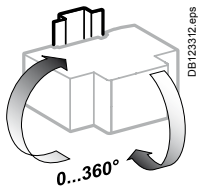

Indifferent position of installation.

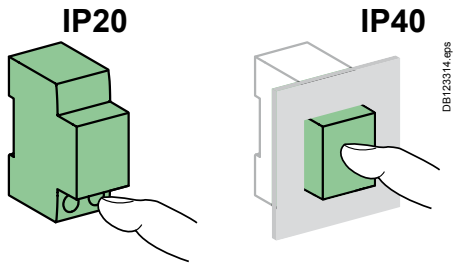



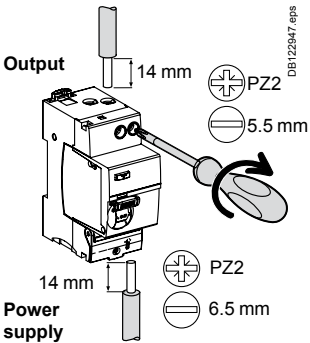

Technical data

Main characteristics		
Insulation voltage (U _i)		500 V AC
Voltage rating (U _e)	Phase-to-neutral	230 V AC
	Phase-to-phase	400 V AC
Rated impulse withstand voltage (U _{imp})		6 kV
According to IEC/EN 61008-2-1		
Rated residual breaking and making capacity (I _{Δm})		1.5 kA
Breaking and making capacity (I _m)		1.5 kA
Conditional rated short circuit current (I _{nc} /I _{Δc})	With circuit breaker	Equal to breaking capacity of the circuit breaker
	25/40 A	With fuse 80 A
	63 A	With fuse 100 A
8/20 μs impulse withstand without tripping	AC and A types	250 Å
	A-SI type	3 kÅ
Behaviour in case of voltage drop		Residual current protection down to 0 V according to IEC/EN 61009-1 § 3.3.8
Additional characteristics		
Degree of protection (IEC 60529)	Device only	IP20
	Device in modular enclosure	IP40
Endurance (O-C)	Electrical (AC1)	15000 cycles
	Mechanical	20000 cycles
Operating temperature	AC type	-5°C to +60°C
	A, A-SI type	-25°C to +60°C
Storage temperature		-40°C to +85°C

Connection



* see Catalog modules CA907001 and CA907015

	Comb busbar	Tightening torque	Without accessory		With accessories*			
			Copper cables		50 mm ² Al terminal	Screw-on connection for ring terminal	Multi-cables terminal	
			Rigid	Flexible or with ferrule			Rigid cables	Flexible cables
								
Top	■	2 N.m	1 to 16 mm ²	1 to 10 mm ²	-	Ø 5 mm	-	-
Bottom	-	3.5 N.m	1 to 35 mm ²	1 to 25 mm ²	50 mm ²	Ø 5 mm	3 x 16 mm ²	3 x 10 mm ²

Weight (g)

Residual current circuit breakers	
Type	Acti9 iID40
1P+N	195
3P+N	360

Dimensions (mm)

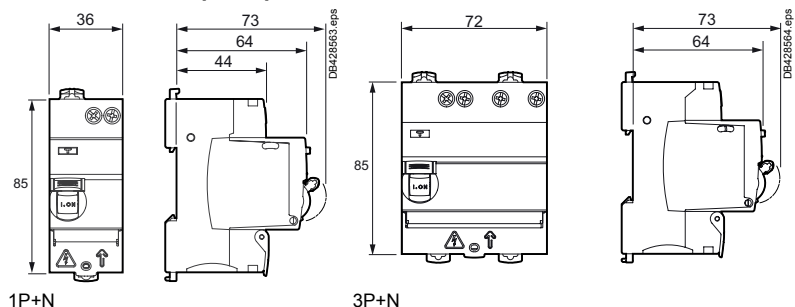

Protection, Earth leakage protection

Acti9 iLD40 residual current circuit breakers bottom connection



PB119567-45.eps

■ Double clip for dismounting with comb busbar in place

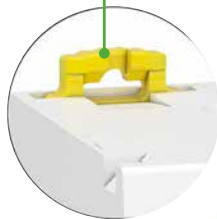

PB119566-40.eps

■ Insulated terminals IP20



DE428467.eps

Output terminals

- Direct power supply of the outgoing by comb busbar
- Compatible with Acti9 horizontal comb busbars with 9 mm modules (catalog module CA907026)

■ Test button

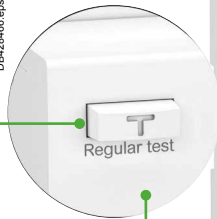

DB428468.eps

VISI-TRIP window

- Fault tripping is indicated by a red mechanical indicator on the front face

■ Indication flap of connection direction
■ Sealing possible



DB428468.eps

Power supply terminals

- 25 mm² flexible



DB428469.eps

VISI-SAFE window

Positive contact indication

- A green strip on the toggle indicates full opening of all the poles
- Downstream maintenance operations can be carried out in better safety conditions
- Padlocking possible

■ Large circuit labelling area

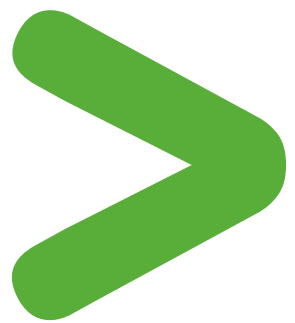

Protection Earth leakage protection

RCCB-ID 125 A residual current circuit breaker (A, SI, B types)

IEC/EN 61008-1
VDE 0664

As per the above standards:

- The RCCB-ID 125 A residual current circuit breakers provide:
 - protection of persons against electric shock by direct contact (30 mA),
 - protection of persons against electric shock by indirect contact (≥ 100 mA),
 - protection of installations against the risk of fire (300 mA or 500 mA).

The **SI** type provides increased immunity from electrical interference and polluted or corrosive environments.

B type

■ The RCCB-ID B type residual current circuit breakers provide specific protection of three-phase installations and people even in the presence of DC fault currents on the network generated by:

- 3-poles controllers and variable speed drives,
- 3-poles battery chargers and inverters,
- 3-poles backed-up power supplies.

Instantaneous

It ensures instantaneous tripping (without time delay).

Selective

It ensures total discrimination with a non-selective RCD placed downstream.

OFsp auxiliary

■ Electrical indication: by OFsp auxiliary mounted to the left, it has a double changeover switch indicating the "open" or "closed" position of the RCCB-ID 125 A.



Accessories

- 2P and 4P sealable screw shield.



Catalogue numbers

RCCB-ID 125 A residual current circuit breakers

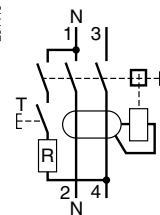
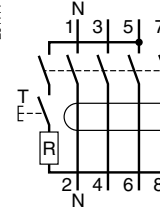
Type		AC 				A 				
		30 mA	100 mA	300 mA	500 mA	30 mA	300 mA	300 mA 	500 mA	
2P 	Sensitivity									
	Rating	125 A				-	16970	16971	-	-
4P 	Sensitivity									
	Rating	125 A				16908	16924	16926	16925	16927
Voltage rating (Ue)		2P	230 V							
		4P	400 V							
Operating frequency		50 Hz								

Protection

Earth leakage protection

RCCB-ID 125 A residual current circuit breaker (A, SI, B types) (cont.)

Catalogue numbers

Auxiliary				Width in 9 mm module
Type			16940	
Contact OFsp	Contact	Voltage		
	1 A	110 V DC		1
	6 A	230 V AC (AC15)		

Accessory		
Type	Number of pole	
Screw shield (set of 10) for upstream or downstream	2P	16938
	4P	16939

Connection

■ By tunnel terminals for:

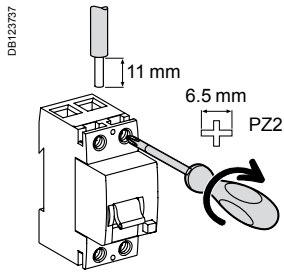

Type	Tightening torque	Copper cables	
		Rigid	Flexible or with ferrule
RCCB-ID	3 N.m	1 x 1.5 to 50 mm ² 2 x 1.5 to 16 mm ²	1 x 1.5 to 35 mm ² 2 x 1.5 to 16 mm ²
OFsp	0.8 N.m	1 to 1.5 mm ²	1 to 1.5 mm ²

							Width in 9 mm module
SI		B					
30 mA	300 mA	-	-	-	-	-	4
16972	16973	-	-	-	-	-	
30 mA	300 mA	30 mA	300 mA	300 mA	500 mA		8
16920	16921	16763	16764	16765	16766		

Protection
Earth leakage protection

RCCB-ID 125 A residual current circuit breaker
(A, SI, B types) (cont.)

Technical data

OFsp contact status, depending on the position of the residual current circuit breaker

Type				
RCCB-ID 125 A	Closed	■	-	-
	Open	-	■	-
	Tripped on fault	-	-	■
Contact OFsp	22/21	Open	Closed	Closed
	12/11			
	14/11	Closed	Open	Open

Electrical characteristics	
Insulation voltage (U _i)	400 V
Pollution degree	3
Rated impulse withstand voltage (U _{imp})	4 kV

According to IEC/EN 61008-1		
Making and breaking capacity (I _m /I _{Δm})	1250 A	
Surge current withstand (8/20 μs) without tripping	AC and A types (no selective ☐)	250 A
	SI and B types (no selective ☐)	3 kA
	AC, A, SI and B types (selective ☐)	3 kA
Conditional rated short circuit current (I _{nc} /I _{Δc})	With FU 125 A gG fuse	10,000 A
Behaviour in case of voltage drop		Residual current protection down to 0 V according to IEC/EN 61008-1 § 3.3.4

Additional characteristics			
Degree of protection	Device only	IP20 IP40 with screw shield	
	Device in modular enclosure	IP40 Insulation class II	
Endurance (O-C)	Electrical	> 2 000 cycles	
	Mechanical	> 5 000 cycles	
Operating temperature		-25°C to +40°C	
	Storage temperature	AC, A, SI types B type	-40°C to +85°C -40°C to +60°C
Range of test button operating voltage	30 mA	2P	160...250 V AC
		4P	250...440 V AC
	100, 300, 500 mA	2P	185...250 V AC
		4P	185...440 V AC



Indication of the status of the RCCB-ID via the 3-position toggle and front panel indicator

- Open (toggle in high position and green indicator)
- Closed (toggle in low position and red indicator)
- Tripped on fault (toggle in middle position and green indicator)

Dielectric test

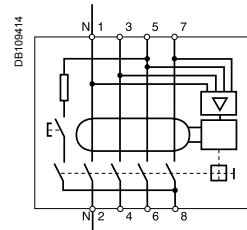
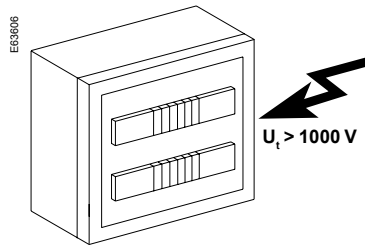

⚠ To perform the dielectric test, disconnect terminals 3, 5, 7 and 4, 6, 8.

Weight (g)

Residual current circuit breakers and auxiliary		
Type	RCCB-ID 125 A	OFsp
2P	230	40
4P AC, A and SI types	420	
B type	500	

Dimensions (mm)

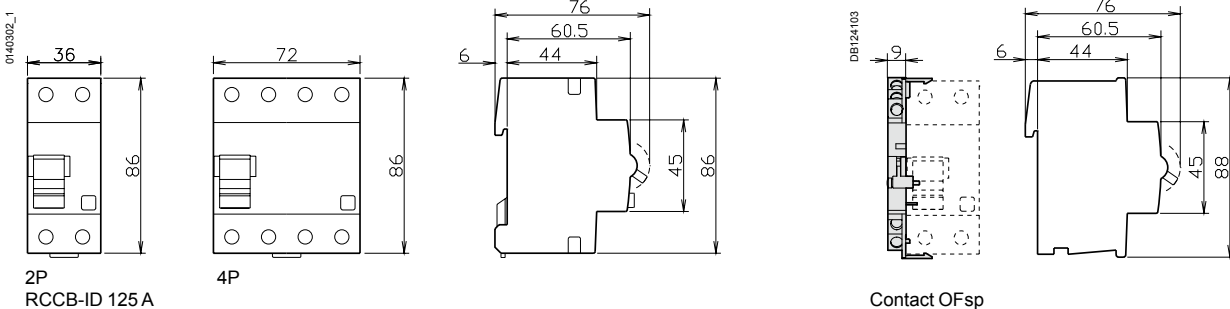

Protection, Earth leakage protection

Acti9 Vigi iC40 add-on residual current devices "Outgoer"



IEC/EN 61009-2-1

As per the above standard:

The residual current devices offer the following earth leakage protection functions:





- protection of persons against electric shock by direct contact (30 mA),
- protection of persons against electric shock by indirect contact (300 mA),
- protection of installations against the risk of fire (300 mA)
- Circuit protection is ensured by a circuit breaker associated to the Vigi add-on.

A-SI type

The A-SI type provides increased immunity from electrical interference and polluted or corrosive environments.

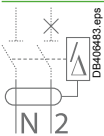
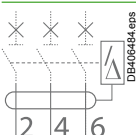
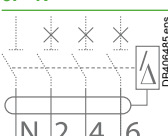

Catalog numbers

Acti9 Vigi iC40 add-on residual current devices "Outgoer"							
Type	A 		A-SI 		Width in 9 mm modules		
Auxiliaries	Without auxiliaries						
1P+N	Sensitivity	30 mA	300 mA	30 mA	300 mA		
	Rating	25 A	A9Y80625	A9Y81625	A9Y84625	A9Y85625	2
		25 A type G	A9Y87625	-	-	-	
		40 A	A9Y80640	A9Y81640	A9Y84640	A9Y85640	
3P	Sensitivity	30 mA	300 mA	30 mA	300 mA		
	Rating	25 A	A9Y80325	A9Y81325	A9Y84325	A9Y85325	4
		40 A	A9Y80340	A9Y81340	A9Y84340	A9Y85340	
3P+N	Sensitivity	30 mA	300 mA	30 mA	300 mA		
	Rating	25 A	A9Y80725	A9Y81725	A9Y84725	A9Y85725	4
		40 A	A9Y80740	A9Y81740	A9Y84740	A9Y85740	
Accessories	Catalog modules CA907001 and CA907015						
 PowerTag energy sensors	Catalog modules CA907029 and CA908058						

Protection, Earth leakage protection

Acti9 Vigi iC40 add-on residual current devices "Outgoer"

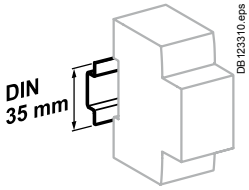

Clip on DIN rail 35 mm.

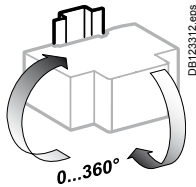

Indifferent position of installation.

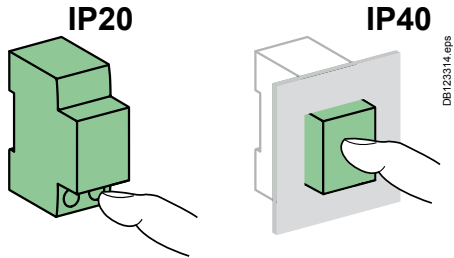

Dimensions (mm)

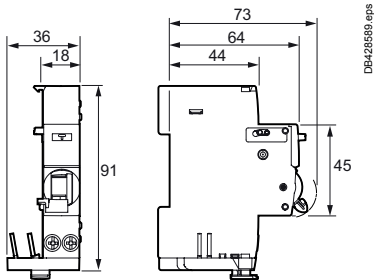

Acti9 Vigi iC40 "Outgoer" 1P+N

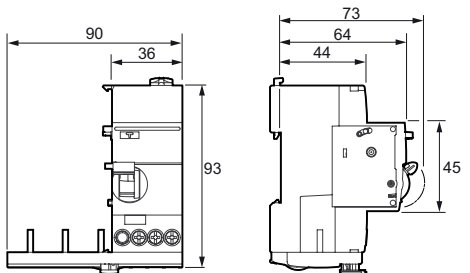

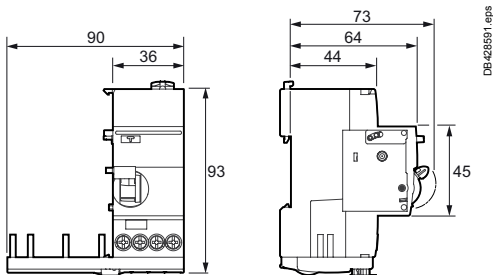

Acti9 Vigi iC40 "Outgoer" 3P



Acti9 Vigi iC40 "Outgoer" 3P+N

Technical data

Main characteristics		
According to IEC/EN 61009-2-1		
Insulation voltage (Ui)	Phase-to-neutral	400 V
	Phase-to-phase	440 V
Voltage rating (Ue)	Phase-to-neutral	230 V
	Phase-to-phase	400 V
Operating frequency		50/60 Hz
8/20 μs impulse withstand without tripping	AC, A types	250 Å
	A-SI type	3 kÅ
Pollution degree		3
Behaviour in case of voltage drop		Residual current protection down to 0 V according to IEC/ EN 61009-1 § 3.3.8
Rated impulse withstand voltage (Uimp)		4 kV
Additional characteristics		
Degree of protection (IEC 60529)	Device only	IP20
	Device in modular enclosure	IP40
Operating temperature		Insulation class II
	AC type	-5°C to +60°C
	A, A-SI types 	-25°C to +60°C
Storage temperature		-40°C to +85°C

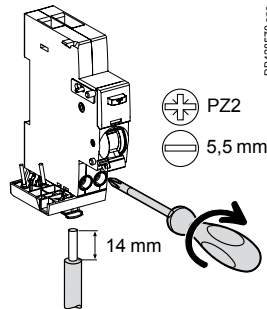

Connection

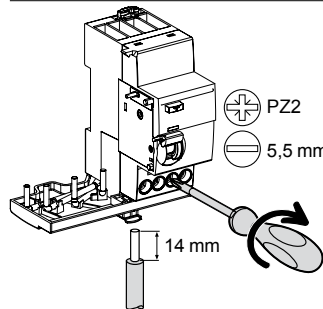

Acti9 Vigi iC40 1P+N



Acti9 Vigi iC40 3P, 3P+N

Tightening torque	Copper cables	
	Rigid	Flexible or with ferrule
2 N.m	 DB122945.eps 1 to 16 mm ²	 DB122946.eps 1 to 10 mm ²
2 N.m	1 to 16 mm ²	1 to 10 mm ²

Weight (g)

Add-on residual current devices	
Type	Acti9 Vigi iC40
1P+N	85
3P	155
3P+N	160

Protection, Earth leakage protection

Acti9 Vigi iC40 add-on residual current devices "Outgoer"

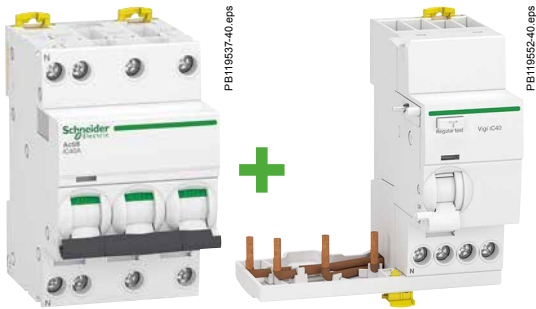

Circuit breaker + Vigi association

Circuit breaker	Vigi 25 A	Vigi 40 A
2 A to 25 A	■	■
32 A - 40 A	-	■

■ Double clip for dismounting with comb busbar in place



DB428853.eps

■ Clear space to allow comb busbar installation

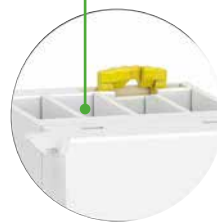

DB428854.eps

■ Large circuit labelling area



PB119532-40.eps

VISI-TRIP window

■ Fault tripping is indicated by a red mechanical indicator on the front face



DB428855.eps

■ Test button



DB428856.eps

■ Insulated terminals IP20



Protection Earth leakage protection

Vigi iC60 add-on residual current devices for iC60 double terminals (A type)

IEC/EN 61009-1



- Combined with iC60 double tunnel terminals circuit breaker, the Vigi iC60 provide:
 - protection of persons against electric shock by direct contact (30 mA),
 - protection of persons against electric shock by indirect contact (≥ 100 mA),
 - protection of installations against the risk of fire (300 mA or 500 mA).



Catalogue numbers

Vigi iC60 add-on residual current devices								
Type	A						Width in 9 mm modules	
Product	Vigi iC60							
Auxiliaries	Without auxiliaries							
	Sensitivity	30 mA	100 mA	300 mA	300 mA	500 mA		
2P 	Rating	25 A	A9W21225	A9W22225	A9W24225	-	A9W26225	3
		63 A	A9W21263	A9W22263	A9W24263	A9W25263	A9W26263	4
3P 	Rating	25 A	A9W21325	-	A9W24325	-	A9W26325	6
		63 A	A9W21363	-	A9W24363	A9W25363	A9W26363	7
4P 	Rating	25 A	A9W21425	A9W22425	A9W24425	-	A9W26425	6
		63 A	A9W21463	A9W22463	A9W24463	A9W25463	A9W26463	7
Voltage rating (Ue)	2P	230 - 240 V						
	3P-4P	400 - 415 V						
Operating frequency	50/60 Hz							
Accessories	Module CA907000							

Protection Earth leakage protection

Vigi iC60 add-on residual current devices for iC60 double terminals (SI type)

IEC/EN 61009-1



- Combined with iC60 double tunnel terminals circuit breaker, the Vigi iC60 provide:
 - protection of persons against electric shock by direct contact (≤ 30 mA),
 - protection of persons against electric shock by indirect contact (≥ 300 mA),
 - protection of installations against the risk of fire (300 mA).

The **SI** type provides increased immunity from electrical interference and polluted or corrosive environments.



Catalogue numbers

Vigi iC60 add-on residual current devices						
Type	SI					Width in 9 mm modules
Product	Vigi iC60					
Auxiliaries	Auxiliaries					
2P 	Sensitivity Rating	25 A	10 mA	30 mA	300 mA	3
		63 A	A9W30225	A9W31225	-	4
			-	A9W31263	A9W35263	
3P 	Sensitivity Rating	25 A	10 mA	30 mA	300 mA	6
		63 A	-	A9W31325	-	7
			-	A9W31363	A9W35363	
4P 	Sensitivity Rating	25 A	10 mA	30 mA	300 mA	6
		63 A	-	A9W31425	-	7
			-	A9W31463	A9W35463	
Voltage rating (Ue)	2P	230 - 240 V				
	3P-4P	400 - 415 V				
Operating frequency	50/60 Hz					
Accessories	Module CA907000					

Protection Earth leakage protection

Vigi iC60 add-on residual current devices for iC60 double terminals (A, SI types)

Connection

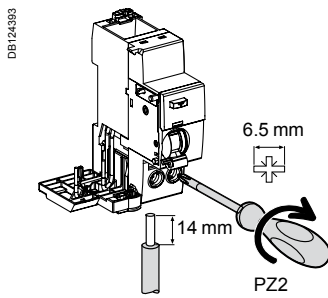

Type	Rating	Tightening torque	Copper cables	
			Rigid	Flexible or with ferrule
Vigi iC60	25 A	2 N.m	1 to 25 mm ²	1 to 16 mm ²
	63 A	3.5 N.m	1 to 35 mm ²	1 to 25 mm ²

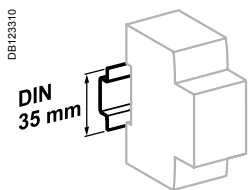

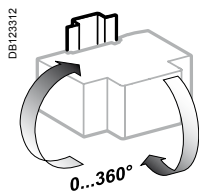

Clip on DIN rail 35 mm.

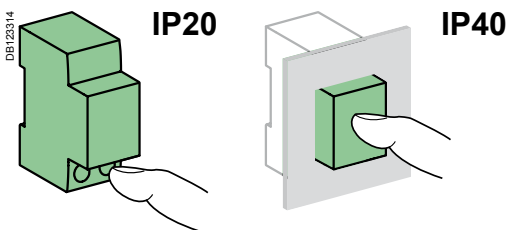

Indifferent position of installation.



Technical data

Main characteristics		
Insulation voltage (U _i)		500 V
Pollution degree		3
Rated impulse withstand voltage (U _{imp})		6 kV
According to IEC/EN 61009-1		
Surge current withstand (8/20 μs) without tripping	AC and A types (no selective)	250 Å
	AC, A types (selective \square)	3 kÅ
	SI type	3 kÅ
Behaviour in case of voltage drop		Residual current protection down to 0 V according to IEC/EN 61009-1 § 3.3.8
Additional characteristics		
Degree of protection	Device only	IP20
	Device in modular enclosure	IP40 Insulation class II
Operating temperature	AC type	-5°C to +60°C
	A and SI types 	-25°C to +60°C
Storage temperature		-40°C to +85°C

Protection
Earth leakage protection

Vigi iC60 add-on residual current devices for iC60 double terminals (A, SI types) (cont.)

Weight (g)

Add-on residual current devices	
Type	Vigi iC60
2P	165
3P	210
4P	245

Dimensions (mm)

Vigi iC60 25 A

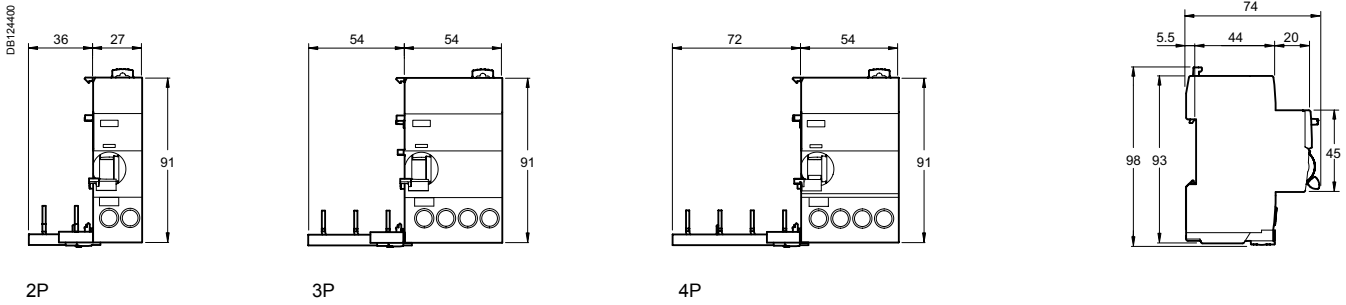

Vigi iC60 63 A

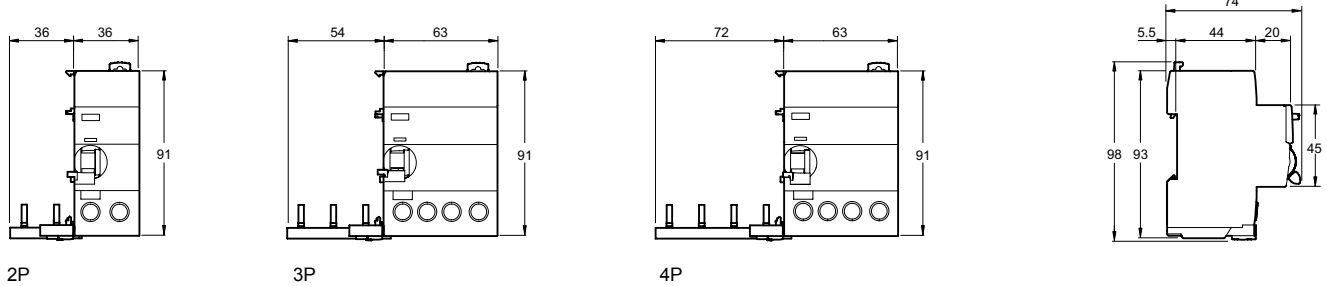

Protection
Earth leakage protection

Vigi iC60 add-on residual current devices for iC60 double terminals (A, SI types) (cont.)

DE124384



Association iC60N, H + Vigi iC60

iC60	Vigi iC60 25 A	Vigi iC60 63 A
0.5 A to 25 A	■	■
32 A - 40 A	NO	■
50 A - 63 A	NO	■

PB107416-60

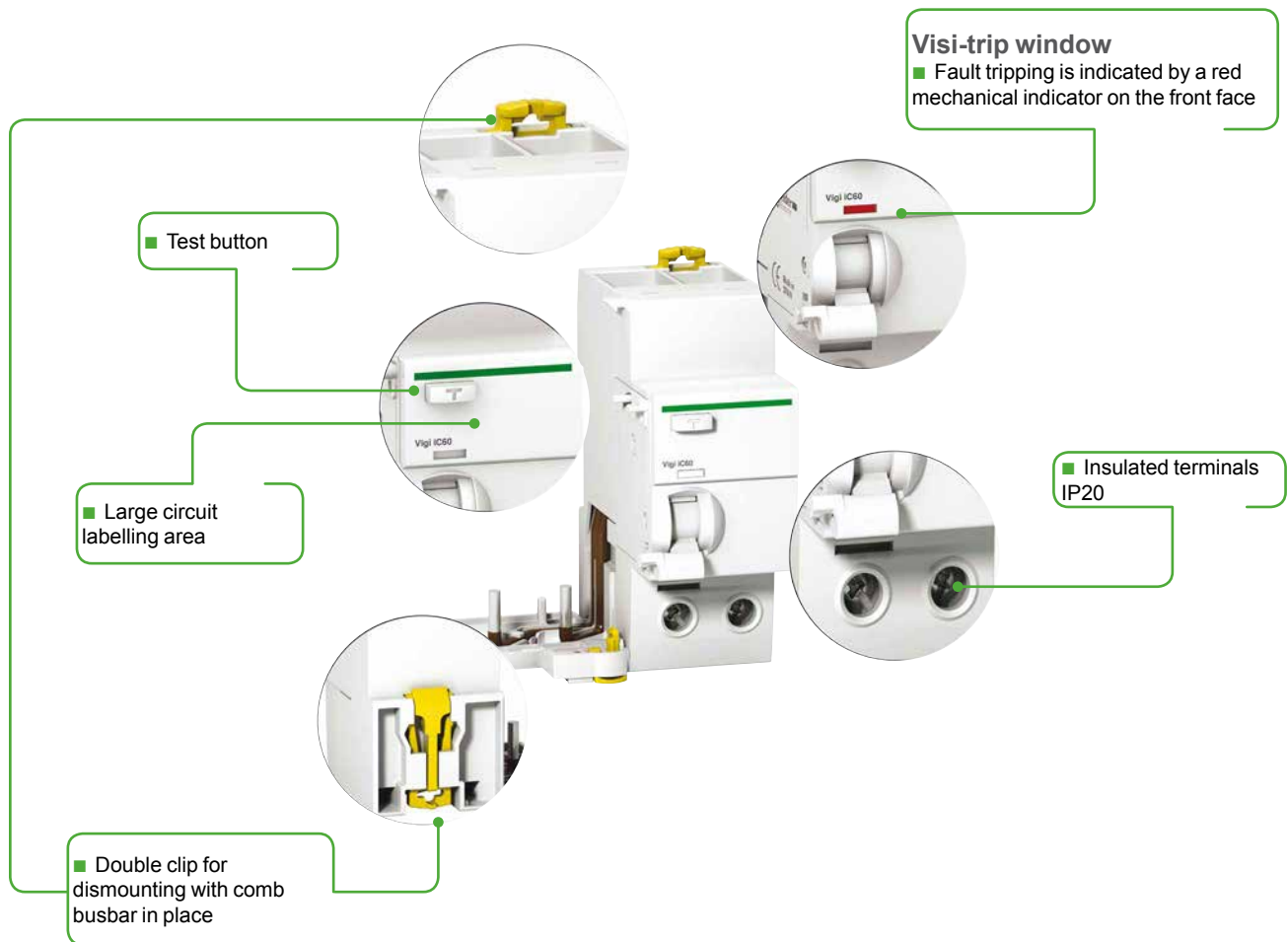

Type SI

The SI type provides increased immunity from electrical interference and polluted or corrosive environments.

Protection Earth leakage protection

Vigi C120 add-on residual current devices (type A)

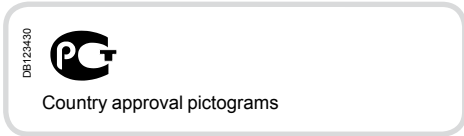

EN 61009

When a Vigi C120 device is combined with a C120 circuit breaker, it provides the following functions:

- protection of persons against electric shock by direct contact (30 mA),
- protection of persons against electric shock by indirect contact (≥ 300 mA),
- protection of installations against fire hazards (300 mA to 1000 mA).



2P













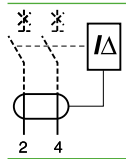

3P

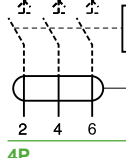

4P

Catalogue numbers

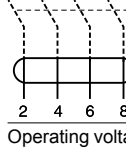
Vigi C120 add-on residual current devices								
Type		A 						Width in 9 mm modules
Product		Vigi C120						
Auxiliaries		Without auxiliary						
2P	Sensitivity	30 mA	300 mA	500 mA	300 mA 	500 mA 	1000 mA 	
		A9N18572	A9N18573	A9N18574	-	-	-	7
3P	Sensitivity	30 mA	300 mA	500 mA	300 mA 	500 mA 	1000 mA 	
		A9N18575	A9N18576	A9N18577	-	-	-	10
4P	Sensitivity	30 mA	300 mA	500 mA	300 mA 	500 mA 	1000 mA 	
		A9N18578	A9N18579	A9N18580	A9N18587	A9N18588	A9N18589	10
Operating voltage (Ue)	2P	230 - 240 V						
	3P-4P	400 - 415 V						
Operating frequency		50/60 Hz						
Accessories		Module CA907012 and CA907013						

Protection Earth leakage protection

Vigi C120 add-on residual current devices (type A-SI)

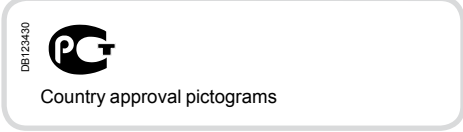

EN 61009

When a Vigi C120 device is combined with a C120 circuit breaker, it provides the following functions:

- protection of persons against electric shock by direct contact (30 mA),
- protection of persons against electric shock by indirect contact (≥ 300 mA),
- protection of installations against fire hazards (300 mA to 1000 mA).

Special feature of type A-SI :

They are appropriate for operating in environments with:

- high risk of nuisance tripping: frequent lightning strikes, IT system, presence of electronic ballasts, frequency converters, presence of switchgear incorporating lighting type interference filters, computer system, etc.
- blind sources:
 - presence of harmonics or high frequency rejections
 - presence of DC components: diodes, diode bridges, switch-mode power supplies, etc.
- protected against nuisance tripping caused by transient voltage surges (lightning strike, operation of switchgear on the network, etc.)

PE107924-30



2P

PE107925-30



3P

PE107926-30



4P

Catalogue numbers

Vigi C120 add-on residual current devices								
Type	A-SI						Width in 9 mm modules	
Product	Vigi C120							
Auxiliaries	Without auxiliary							
2P Sensitivity	30 mA A9N18591	300 mA A9N18592	500 mA -	300 mA A9N18556	1000 mA A9N18557		7	
3P Sensitivity	30 mA A9N18594	300 mA A9N18595	500 mA -	300 mA A9N18558	1000 mA A9N18559		10	
4P Sensitivity	30 mA A9N18597 A9N18554 ⁽¹⁾	300 mA A9N18598 A9N18555 ⁽¹⁾	500 mA A9N18599	300 mA A9N18560	1000 mA A9N18561		10	
Operating voltage (Ue)	2P	230 - 240 V						
	3P-4P	400 - 415 V						
Operating frequency	50 Hz							
Accessories	Module CA907012 and CA907013							

(1) specific offer for France

Protection

Earth leakage protection

Vigi C120 add-on residual current devices (types A and A-SI)

Connection

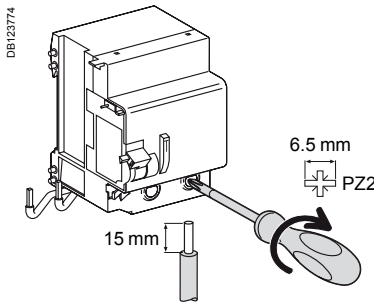

Type	Sensitivity	Tightening torque	Copper cables	
			Rigid	Flexible or with ferrule
Vigi C120	30...1000 mA	3.5 N.m	1 to 50 mm ²	1 to 35 mm ²

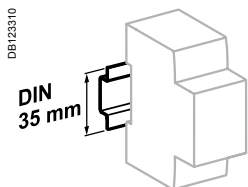

Clips onto 35 mm DIN rail.

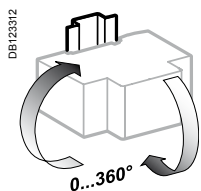

Any installation position.

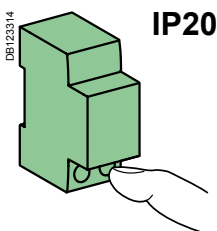

IP20

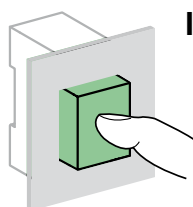

IP40

Technical data

Main characteristics

To IEC 60947-2

Insulation voltage (U _i)	500 V AC
Degree of pollution	3
Rated impulse withstand voltage (U _{imp})	6 kV

To EN 61009

Impulse current withstand (8/20 μs) without tripping	Types AC and A (non-selective ☒)	250 Å
	Types AC and A (selective ☒)	3 kÅ
	Types A-SI (non-selective ☒)	3 kÅ
	Types A-SI (selective ☒)	5 kÅ

Additional characteristics

Degree of protection	Device only	IP20
	Device in a modular enclosure	IP40
Operating temperature	Type AC	-5 °C to +60 °C
	Types A and A-SI	-25 °C to +60 °C
Storage temperature		-40 °C to +85 °C

Weight (g)

Add-on residual current devices

Type	Vigi C120
2P	325
3P	500
4P	580

Dimensions (mm)

C120 + Vigi C120

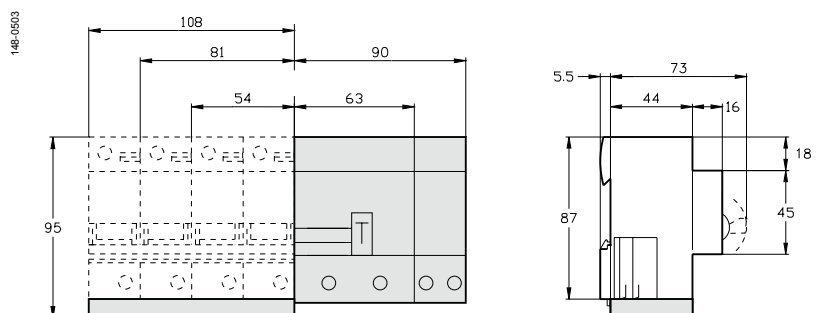

Protection

Earth leakage protection

Vigi C120 add-on residual current devices (types A and A-SI) (cont.)

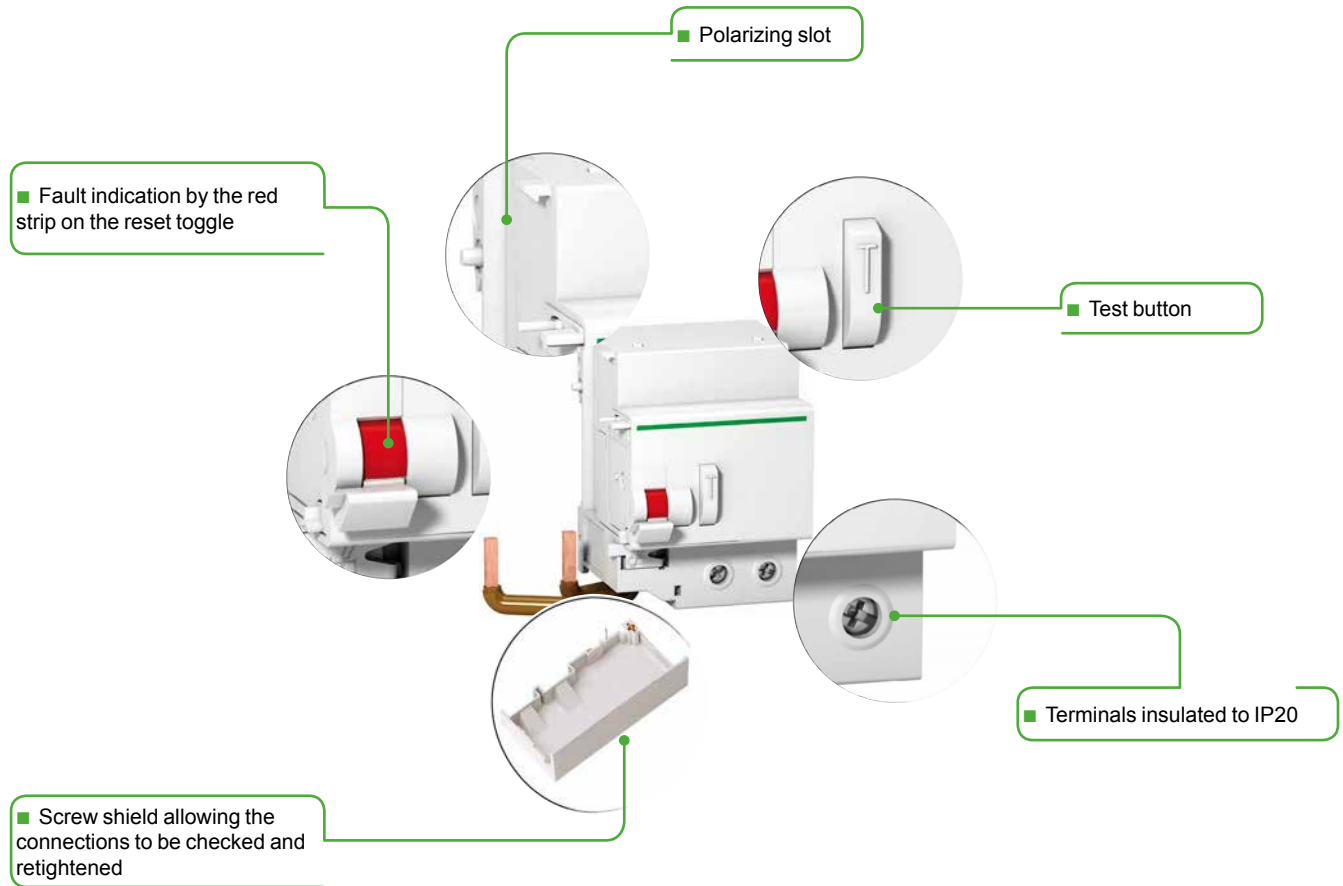

Type A-SI

The A-SI type provides increased immunity from electrical interference and polluted or corrosive environments.

Protection Earth leakage protection

Vigi NG125 add-on residual current devices (A type)

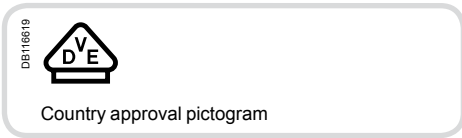

IEC/EN 61009-1

054383M-40

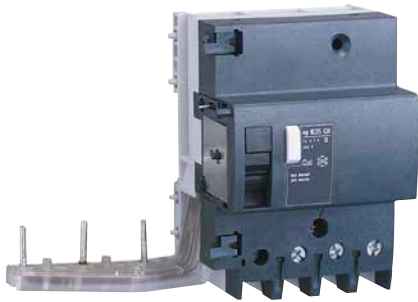

PB103988-40



- When it is combined with an NG125 circuit breaker, the Vigi NG125 add-on residual current device offers the following functions:
 - protection of persons against electric shocks by direct contact (30 mA),
 - protection of persons against electric shocks by indirect contact (≥ 300 mA),
 - protection of installations against fire risks (300 mA or 500 mA).

Catalogue numbers

Vigi NG125 add-on residual current devices									
Type	A							Width in 9 mm modules	
Product	Vigi NG125								
Auxiliaries	Module CM907005								
	Sensitivity	30 mA	300 mA	300 mA	1000 mA	300...1000 I/S	300...3000 I/S/R		
2P DB122462	Rating 63 A	19010 19008 (1)	19012 19009 (1)	19030	19031	-	-	5	
	Rating 125 A	19039	-	-	-	19044	19047 19055 (2)	11	
3P DB122463	Rating 63 A	19013	19014	19032	19033	-	-	9	
	Rating 125 A	19039	-	-	-	19044	19047 19055 (2)	11	
4P DB122464	Rating 63 A	19015	19016	19034	19035	-	-	9	
	Rating 125 A	19041	19042	-	-	19046	19049 19056 (2)	11	
Voltage rating (Ue)	230 - 240 V, 400 - 415 V Except: (1) 110...220 V and (2) 440...500 V								
Operating frequency	50/60 Hz								
Accessories	Module CM907006								

Protection Earth leakage protection Vigi NG125 add-on residual current devices (SI type)

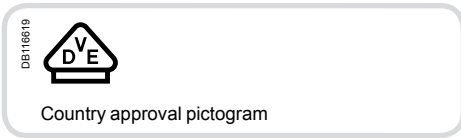

067484-140

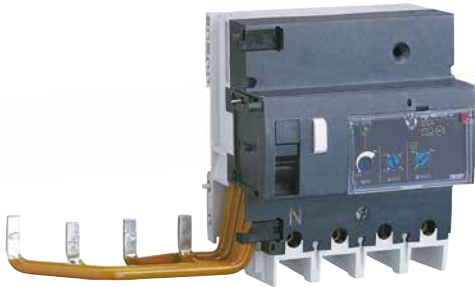

IEC/EN 61009-1

- When it is combined with an NG125 circuit breaker, the Vigi NG125 add-on residual current device offers the following functions:
 - protection of persons against electric shocks by direct contact (30 mA),
 - protection of persons against electric shocks by indirect contact (≥ 300 mA),
 - protection of installations against fire risks (300 mA or 500 mA).

SI types are appropriate for operating in environments with:

- High risk of nuisance tripping: frequent lightning strikes, IT system, presence of electronic ballasts, frequency converters, presence of switchgear incorporating lighting type interference filters, computer system, etc.
- Blind sources
 - presence of harmonics or high frequency rejections,
 - presence of DC components: diodes, diode bridges, switch-mode power supplies, etc.
- Protected against nuisance tripping caused by transient voltage surges (lightning strike, operation of switchgear on the network, etc.).

Catalogue numbers

Vigi NG125 add-on residual current devices					
Type	SI		Vigi NG125		Width in 9 mm modules
Product	Module CM907005				
Auxiliaries	Module CM907005				
3P	Sensitivity	30 mA	300...3000 I/S/R		
	Rating	125 A	19100	19106	11
4P	Sensitivity	30 mA	300...3000 I/S/R		
	Rating	125 A	19101	19107	11
Voltage rating (Ue)			230 - 240 V, 400 - 415 V		
Operating frequency			50/60 Hz		
Accessories			Module CM907006		

Protection
Earth leakage protection

Vigi NG125 add-on residual current devices
(A, SI types)

Connection

		Without accessories			With accessories	
Rating	Tightening torque	Copper cables			70 mm ² Al terminal	Screw-on connection for ring terminal
		Rigid	Flexible or with ferrule	Screw clamp terminal		
 DB123404	63 A	3.5 N.m	1.5 to 50 mm ²	1 to 35 mm ²	-	-
 DB123405	125 A	6 N.m	16 to 70 mm ²	10 to 50 mm ²	25 to 70 mm ²	2 x 35 mm ² 1 x 50 mm ²
 DB123406	Pre-alarm	1 N.m	2 x 2.5 mm ²	2 x 1.5 mm ²	2 x 1.5 mm ²	-

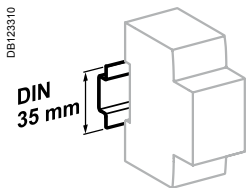

Clip on DIN rail 35 mm.

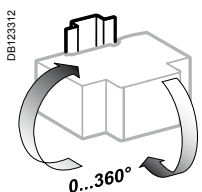

Indifferent position of installation.

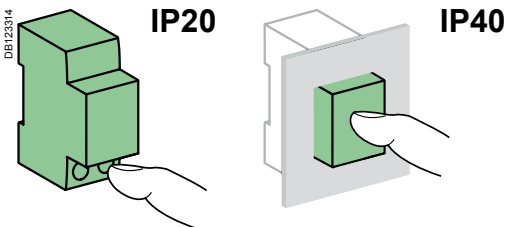

Technical data

Main characteristics		
Insulation voltage (U _i)		690 V
Pollution degree		3
Rated impulse withstand voltage (U _{imp})		8 kV
According to IEC/EN 61009-1		
Surge current withstand (8/20 μs) without tripping	Selective <input type="checkbox"/> or R	5 kA
	Instantaneous	3 kA
Behaviour in case of voltage drop		Residual current protection down to 0 V according to IEC/EN 61009-1 § 3.3.8
Additional characteristics		
Degree of protection	Device only	IP20
	Device in modular enclosure	IP40
Operating temperature	AC type	-5°C to +60°C
	A and SI types	-25°C to +60°C
Storage temperature		-40°C to +85°C
Additional characteristics		
Vigi 125 A and adjustable		
Plug-in auxiliaries	MXV	Remote tripping
	SDV	Indication of tripping upon earth fault
Adjustable Vigi		
Sensitivity adjustable by notch (IΔn)		300, 500, 1000, 3000 mA
Tripping time	Instantaneous	
	Selective <input type="checkbox"/>	60 ms
	Time-delayed	150 ms
Leakage current indication on 3P and 4P 300...3000 I/S/R (pre-alarm)		On front face by LED Remote, by potential-free normally-open contact 250 V - 1 A (low level) Threshold setting by potentiometer from 10 % to 50 % of IΔn
Disconnection essential for dielectric test		By integral pushbutton

Protection

Earth leakage protection

Vigi NG125 add-on residual current devices (A, SI types) (cont.)

Weight (g)

Add-on residual current devices			
Number of 9 mm modules	2P	3P	4P
5 modules	250	-	-
9 modules	-	410	450
11 modules	-	750	800

Dimensions (mm)

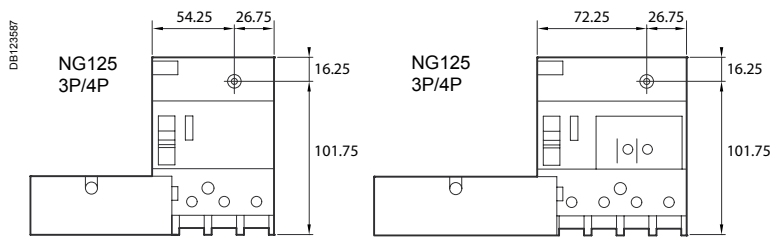
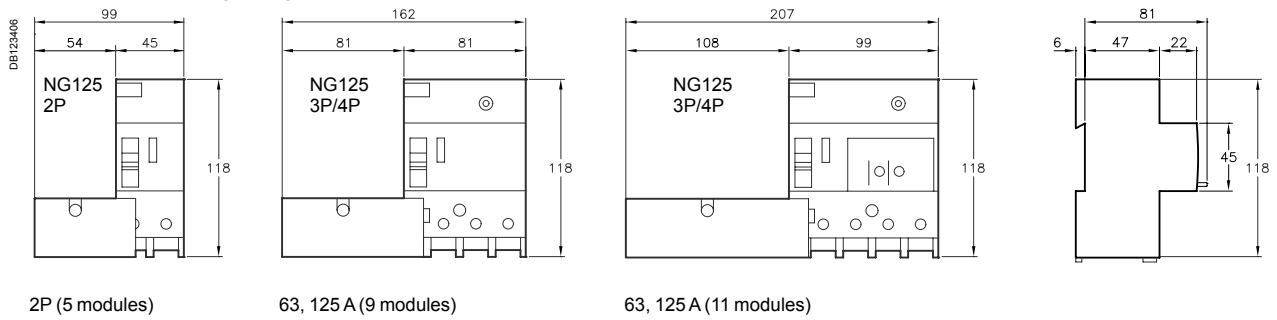

Spacing for mounting on panel

Protection

Earth leakage protection

Vigi NG125 add-on residual current devices (A, SI types) (cont.)

058341_SE-50



Association NG125 + Vigi NG125

	Vigi NG125 63 A	Vigi NG125 125 A
NG125 ≤ 63 A	■	NO
NG125 80...125 A*	NO	■

(*) No Vigi add-on residual current device for 2P circuit breakers of rating 80 A.

FB10446-40

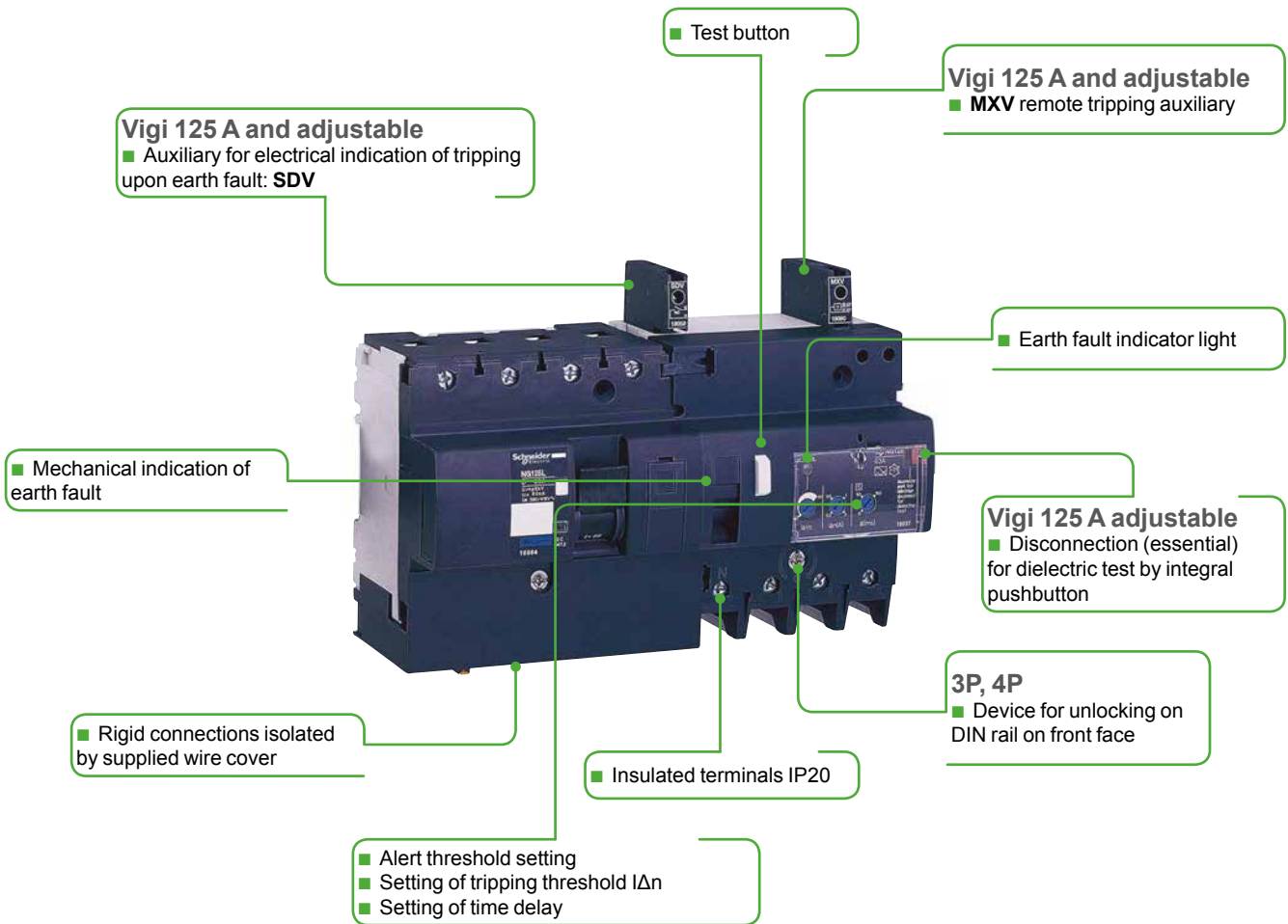

SI type

SI types are appropriate for operating in environments with:

- High risk of nuisance tripping: frequent lightning strikes, IT system, presence of electronic ballasts, frequency converters, presence of switchgear incorporating lighting type interference filters, computer system, etc.
- Blind sources
- presence of harmonics or high frequency rejections,
- presence of DC components: diodes, diode bridges, switch-mode power supplies, etc.
- Protected against nuisance tripping caused by transient voltage surges (lightning strike, operation of switchgear on the network, etc.).

Protection,
Earth leakage protection

Acti9 iCV40N residual current devices RCBO
6000 A

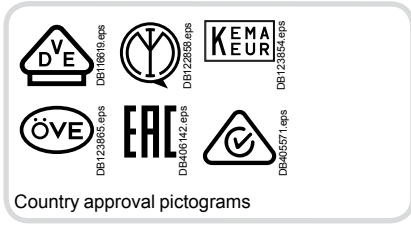

CEI/EN 61009-2-1

As per the above standard:
The residual current devices offers the following functions of earth leakage protection and circuit protection.

- Earth leakage protection:
 - protection of persons against electric shock by direct contact (≤ 30 mA),
 - protection of persons against electric shock by indirect contact (300 mA),
 - protection of installations against the risk of fire (300 mA).
- Circuit protection:
 - circuit protection against short-circuit currents,
 - circuit protection against overload currents,
 - disconnection.

A-SI type

The A-SI type provides increased immunity from electrical interference and polluted or corrosive environments.

Catalog numbers

Acti9 iCV40N RCBO - B curve							
Type	A						Width in 9-mm modules
Auxiliaries	Catalog module CA907002						
1P+N	Sensitivity	10 mA	30 mA	100 mA			
	Rating 6 A	-	A9DG3606	-	4		
	10 A	A9DGA610	A9DG3610	-			
	13 A	-	A9DG3613	-			
	16 A	A9DGA616	A9DG3616	-			
	20 A	-	-	-			
	25 A	-	-	-			
	32 A	-	-	A9DGB632			
40 A	-	-	A9DGB640				
3P+N	Sensitivity	10 mA			100 mA		
	Rating 10 A	-	A9DG3710		-	10	
	13 A	-	A9DG3713		-		
	16 A	-	A9DG3716		-		
Accessories	Catalog modules CA907001 and CA907015						
Comb busbars	Catalog module CA907026						
PowerTag energy sensors	Catalog modules CA907029 and CA908058						

Acti9 iCV40N RCBO - C curve								
Type	A					A-SI		Width in 9-mm modules
Auxiliaries	Catalog module CA907002							
1P+N	Sensitivity	10 mA	30 mA	100 mA	300 mA	30 mA	300 mA	
	Rating 6 A	-	A9DC3606	-	-	A9DF3606	A9DF7606	4
	10 A	A9DCA610	A9DC3610	-	-	A9DF3610	A9DF7610	
	13 A	-	A9DC3613	-	-	A9DC7613	A9DF3613	
	13 A type G	-	A9DCG613	-	-	-	-	
	16 A	A9DCA616	A9DC3616	-	-	A9DC7616	A9DF3616	A9DF7616
	20 A	-	A9DC3620	-	-	-	A9DF3620	A9DF7620
	25 A	-	A9DC3625	-	-	-	A9DF3625	A9DF7625
	32 A	-	A9DC3632	A9DCB632	-	-	A9DF3632	A9DF7632
40 A	-	A9DC3640	A9DCB640	-	-	A9DF3640	A9DF7640	
3P+N	Sensitivity	10 mA	30 mA	100 mA	300 mA	30 mA	300 mA	
	Rating 10 A	-	A9DC3710	-	-	A9DC7710	A9DF3710	10
	13 A	-	A9DC3713	-	-	-	A9DF3713	-
	16 A	-	A9DC3716	-	-	A9DC7716	A9DF3716	-
	20 A	-	A9DC3720	-	-	-	A9DF3720	-
	25 A	-	A9DC3725	-	-	-	A9DF3725	-
	32 A	-	A9DC3732	-	-	-	A9DF3732	-
40 A	-	A9DC3740	-	-	-	A9DF3740	-	
Accessories	Catalog modules CA907001 and CA907015							
Comb busbars	Catalog module CA907026							
PowerTag energy sensors	Catalog modules CA907029 and CA908058							

Protection, Earth leakage protection

Acti9 iCV40N residual current devices RCBO 6000 A

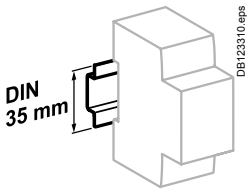

Clip on DIN rail 35 mm.

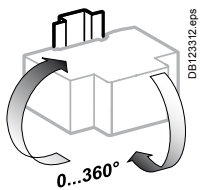

Indifferent position of installation.

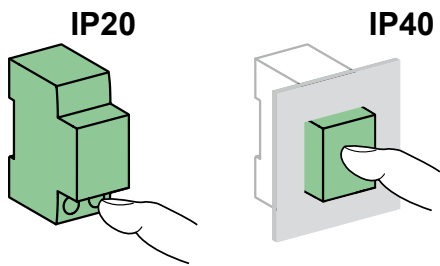

Dimensions (mm)

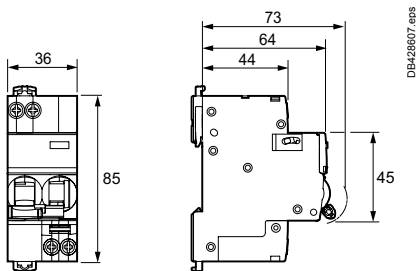

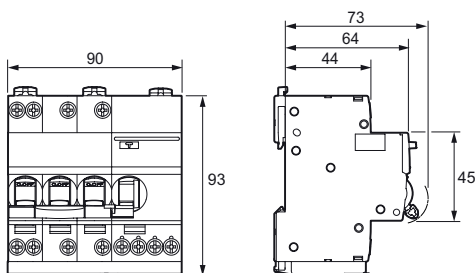

Residual current devices 1P+N



Residual current devices 3P+N

Technical data

Main characteristics			
Insulation voltage (Ui)	Phase-to-neutral		400 V
	Phase-to-phase		440 V
Voltage rating (Ue)	Phase-to-neutral		230 V
	Phase-to-phase		400 V
Operating frequency			50/60 Hz
According to EN 61009-2-1			
Rated impulse withstand voltage (Uimp)			4 kV
Magnetic tripping	B curve		3 to 5 In
	C curve		5 to 10 In
Operating temperature			30°C
Limitation class			3
Rated breaking capacity (Icn)			6000 A
Service breaking capacity (Ics)			100 % Icn
Rated residual breaking and making capacity (IΔm)	1P+N	IEC 61009-2-1	500 A
		EN 61009-2-1	4500 A
	3P+N	IEC/EN 61009-2-1	3000 A
8/20 μs impulse withstand without tripping	AC type		250 Å
	A type		250 Å
	A-SI type		3 kÅ
Pollution degree			3
Behaviour in case of voltage drop			Residual current protection down to 0 V according to NF/EN 61009-1 § 3.3.8
Additional characteristics			
Degree of protection (IEC 60529)	Device only		IP20
	Device in modular enclosure		IP40 Insulation class II
Endurance (O-C)	Electrical	≤ 25 A	20000 cycles
		≥ 32 A	10000 cycles
	Mechanical		20000 cycles
Operating temperature	AC type		-5°C to +60°C
	A, A-SI types		-25°C to +60°C
Storage temperature			-40°C to +85°C

Weight (g)

Residual current devices		
Type	Acti9 iCV40N RCBO	
1P+N		210
3P+N		500

Protection, Earth leakage protection

Acti9 iCV40H residual current devices RCBO 10000 A

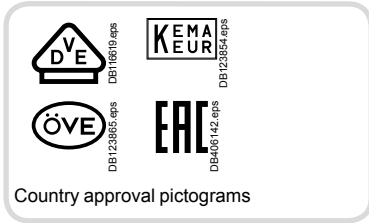

CEI/EN 61009-2-1

As per the above standard:
The residual current devices offers the following functions of earth leakage protection and circuit protection.

- Earth leakage protection:
 - protection of persons against electric shock by direct contact (30 mA),
 - protection of persons against electric shock by indirect contact (300 mA),
 - protection of installations against the risk of fire (300 mA).
- Circuit protection:
 - circuit protection against short-circuit currents,
 - circuit protection against overload currents,
 - disconnection.

A-SI type

The A-SI type provides increased immunity from electrical interference and polluted or corrosive environments.



Catalog numbers

Acti9 iCV40H RCBO - B curve					
Type	A		A-SI		Width in 9-mm modules
Auxiliaries	Catalog module CA907002				
1P+N	Sensitivity 30 mA				
	Rating	6 A	A9DG4606		4
		10 A	A9DG4610		
		16 A	A9DG4616		
		20 A	A9DG4620		
		25 A	A9DG4625		
		32 A	A9DG4632		
Accessories	Catalog modules CA907001 and CA907015				
Comb busbars	Catalog module CA907026				
PowerTag energy sensors	Catalog modules CA907029 and CA908058				

Catalog numbers

Acti9 iCV40H RCBO - C curve						
Type	A		A-SI		Width in 9-mm modules	
Auxiliaries	Catalog module CA907002					
1P+N	Sensitivity 30 mA		300 mA			
	Rating	6 A	A9DC4606	A9DC8606	A9DF4606	A9DF8606
		10 A	A9DC4610	A9DC8610	A9DF4610	A9DF8610
		16 A	A9DC4616	A9DC8616	A9DF4616	A9DF8616
		20 A	A9DC4620	A9DC8620	A9DF4620	A9DF8620
		25 A	A9DC4625	A9DC8625	A9DF4625	A9DF8625
		32 A	A9DC4632	A9DC8632	A9DF4632	A9DF8632
3P+N	Sensitivity 30 mA		300 mA			
	Rating	6 A	A9DC4706	-	-	-
		10 A	A9DC4710	-	-	-
		13 A	A9DC4713	-	-	-
		16 A	A9DC4716	-	-	-
		20 A	A9DC4720	-	-	-
		25 A	A9DC4725	-	-	-
	32 A	A9DC4732	-	-	-	
Accessories	Catalog modules CA907001 and CA907015					
Comb busbars	Catalog module CA907026					
PowerTag energy sensors	Catalog modules CA907029 and CA908058					

Protection,
Earth leakage protection

Acti9 iCV40H residual current devices RCBO
10000 A

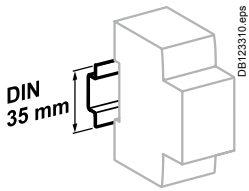

Clip on DIN rail 35 mm.

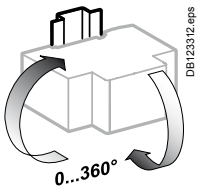

Indifferent position of installation.

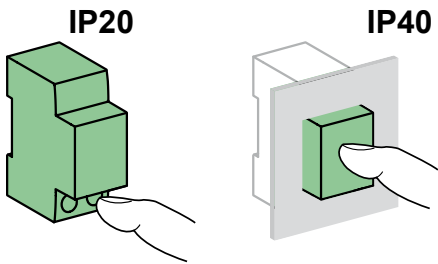

Dimensions (mm)

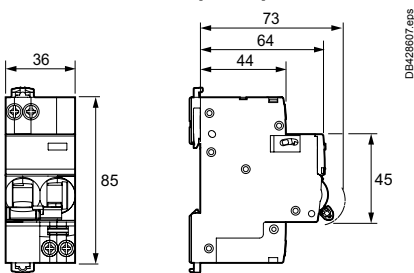

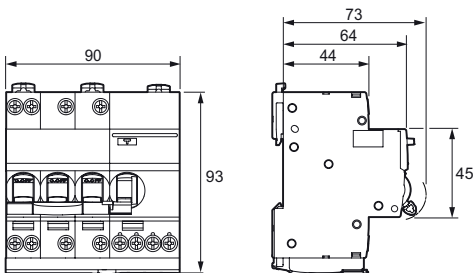

Residual current devices 1P+N



Residual current devices 3P+N

Technical data

Main characteristics			
Insulation voltage (U _i)	Phase-to-neutral	400 V	
	Phase-to-phase	440 V	
Voltage rating (U _e)	Phase-to-neutral	230 V	
	Phase-to-phase	400 V	
Operating frequency	50/60 Hz		
According to EN 61009-2-1			
Rated impulse withstand voltage (U _{imp})	4 kV		
Magnetic tripping	B curve	3 to 5 I _n	
	C curve	5 to 10 I _n	
Operating temperature	30°C		
Limitation class	3		
Rated breaking capacity (I _{cn})	10000 A		
Service breaking capacity (I _{cs})	75 % I _{cn}		
Rated residual breaking and making capacity (I _{Δm})	1P+N	IEC 61009-2-1	500 A
		EN 61009-2-1	4500 A
	3P+N	EC/EN 61009-2-1	3000 A
8/20 μs impulse withstand without tripping	AC type	250 A	
	A type	250 A	
	A-SI type	3 kA	
Pollution degree	3		
Behaviour in case of voltage drop			Residual current protection down to 0 V according to NF/EN 61009-1 § 3.3.8
Additional characteristics			
Degree of protection (IEC 60529)	Device only	IP20	
	Device in modular enclosure	IP40 Insulation class II	
Endurance (O-C)	Electrical	≤ 25 A	20000 cycles
		32 A	10000 cycles
Operating temperature	Mechanical	20000 cycles	
		AC type	-5°C to +60°C
	A, A-SI types	-25°C to +60°C	
			
Storage temperature	-40°C to +85°C		

Weight (g)

Residual current devices	
Type	Acti9 iCV40H RCBO
1P+N	210
3P+N	500

Protection, Earth leakage protection Acti9 iCV40 residual current devices RCBO

■ Automatic cable guiding in the correct position: terminals with guard

■ Reinforced cable pull-out strength: serrated terminals

■ Assembly and disassembly with comb busbar in place by operating toggle latches at the top and bottom of the products

■ Where there is a comb tooth, the connection of cables of cross section 16 mm² remains possible

■ Clear space to allow comb busbar installation

■ Insulated terminals IP20

Markings

■ Area for marking by 12 mm high label on the front panel

Markings

■ Area for 4 marking clips alongside the downstream terminal

VISI-TRIP window

■ Fault tripping is indicated by a red mechanical indicator on the front face



VISI-SAFE window

Positive contact indication

- A green strip on the toggle indicates full opening of all the poles
- Downstream maintenance operations can be carried out in better safety conditions
- Padlocking possible

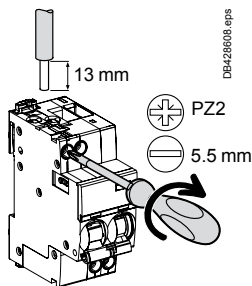
Connection



Type	Connection	Tightening torque	Comb busbar	Copper cables	
				Rigid	Flexible or with ferrule
Acti9 iCV40	Top	2 N.m	■	 1 to 16 mm ²	 1 to 10 mm ²
	Bottom		■		

- Connection by comb busbar or cables (as per EN 50027).
- Where there is a comb busbar tooth, the connection of cables of cross section 16 mm² remains possible.
- See Comb busbars Choice guide (CA908048).

Protection

Earth leakage protection

Residual current device iC60 RCBO

6000 A

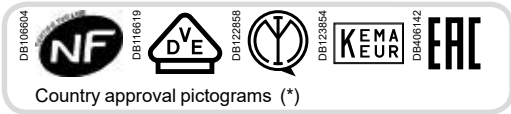

(*) Information to be supplied by the country.

IEC/EN 61009-1
IEC/EN 61009-2-1

As per the above standards:

The iC60 RCBO residual current device provides:

- protection of final circuits against overcurrents and short-circuits.
- protection for people against electric shocks by direct contacts.
- earth fault indication by a red mechanical indicator in front face.

The A-SI type provides increased immunity from electrical interference.



Catalogue numbers

iC60 RCBO 6000 400 V AC				
Type	Curve	A	Width in 9-mm modules	
3P 	Sensitivity (IΔn)	C	6	
		30 mA		
		10 A		A9D67310
		13 A		A9D67313
		16 A		A9D67316
		20 A		A9D67320
		25 A		A9D67325
32 A	A9D67332			
Voltage rating (Ue)		400 V CA		
Operating frequency		50 Hz		
Auxiliaries and accessories		Catalog module CA902045E		

iC60 RCBO 6000 400 V AC									
Type	Curve	AC		A			A-SI		Width in 9-mm modules
		C	300 mA	B	C	300 mA	B	C	
4P 	Sensitivity (IΔn)	30 mA	300 mA	30 mA	30 mA	300 mA	30 mA	30 mA	8
		10 A		A9D87410	A9D67410	A9D52410	A9D97410	A9D77410	
		13 A		A9D87413	A9D67413	-	A9D97413	A9D77413	
		16 A		A9D87416	A9D67416	A9D52416	A9D97416	A9D77416	
		20 A		A9D87420	A9D67420	A9D52420	A9D97420	A9D77420	
		25 A		A9D87425	A9D67425	A9D52425	A9D97425	A9D77425	
		32 A		A9D87432	A9D67432	A9D52432	A9D97432	A9D77432	
Voltage rating (Ue)		400 V CA							
Operating frequency		50 Hz							
Auxiliaries and accessories		Catalog module CA902045E							

Protection

Earth leakage protection

Residual current device iC60 RCBO

10000 A

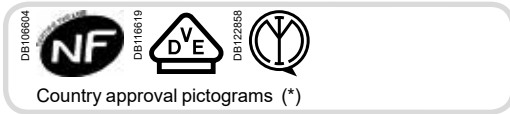

IEC/EN 61009-1
IEC/EN 61009-2-1

As per the above standards:
The iC60 RCBO residual current device provides:

- protection of final circuits against overcurrents and short-circuits.
- protection for people against electric shocks by direct contacts.
- earth fault indication by a red mechanical indicator in front face.

The A-SI type provides increased immunity from electrical interference.

(*) Information to be supplied by the country.



Catalogue numbers

iC60 RCBO 10000 230 V AC									
Type	AC	A			A-SI		Width in 9-mm modules		
Curve	C	B	C	B	C	B	C		
2P	Sensitivity (IΔn)	30 mA	300 mA	30 mA	30 mA	300 mA	30 mA	30 mA	
	Rating (In)			A9D37210	A9D17210	A9D54210	A9D47210	A9D27210	4
	10 A			A9D37213	A9D17213	-	A9D47213	A9D27213	
	13 A			A9D34215	A9D14215	-	-	-	
	15 A, NEK 400			A9D37216	A9D17216	A9D54216	A9D47216	A9D27216	
	16 A			A9D37220	A9D17220	A9D54220	A9D47220	A9D27220	
	20 A			A9D37225	A9D17225	A9D54225	A9D47225	A9D27225	
	25 A			A9D37232	A9D17232	A9D54232	A9D47232	A9D27232	
32 A									
Voltage rating (Ue)	230 V CA								
Operating frequency	50 Hz								
Auxiliaries and accessories	Catalog module CA902045E								

iC60 RCBO 10000 230 V AC			
Type	A	Width in 9-mm modules	
Curve	C		
3P	Sensitivity (IΔn)	30 mA	
	Rating (In)	A9D17310	6
	10 A	A9D17313	
	13 A	A9D17316	
	16 A	A9D17320	
	20 A	A9D17325	
	25 A	A9D17332	
32 A			
Voltage rating (Ue)	230 V CA		
Operating frequency	50 Hz		
Auxiliaries and accessories	Catalog module CA902045E		

Residual current device iC60 RCBO (cont.)

Connection

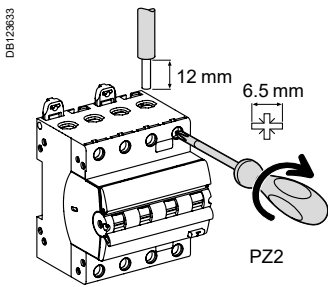

Rating	Tightening torque	Copper cables	
		Rigid	Flexible or with ferrule
10 to 32 A	2 N.m	1 to 35 mm ²	1 to 25 mm ²

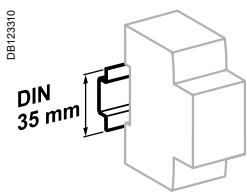

Clip on DIN rail 35 mm.

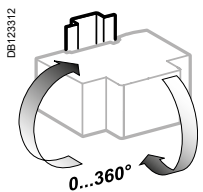

Indifferent position of installation.

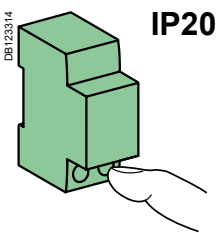

IP20

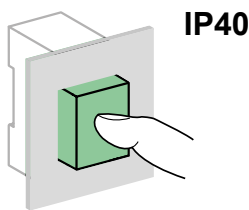

IP40

Dimensions (mm)

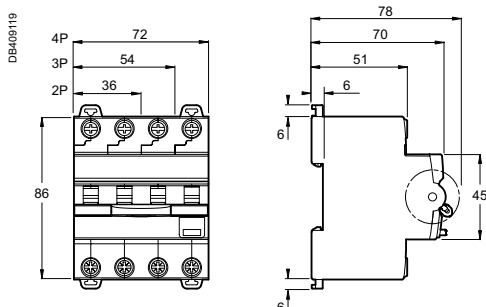

Caractéristiques techniques

Main characteristics	6000 A	10000 A
Insulation voltage (Ui)	500 V	
Rated impulse withstand voltage (Uimp)	4 kV	
Rated residual operating current (IΔn)	30 mA, 300 mA	
Earth leakage protection type	AC, A, A-SI	
Thermal tripping	Reference temperature	30°C
Magnetic tripping	Curve B	Between 3 and 5 In
	Curve C	Between 5 and 10 In
Limitation class	2P	3
	3P, 4P	1
Surge current withstand (8/20 μs) without tripping	AC Type	250 Å
	A Type	250 Å
	A-SI Type	3 kÅ
According to IEC/EN 61009-1 and IEC/EN 61009-2-1		
Rated breaking capacity (Icn)	6000 A	10000 A
Service breaking capacity (Ics)	1 x Icn	0,75 x Icn
Rated residual breaking and making capacity phase/earth (IΔm)	6000 A	6000 A
Behaviour in case of voltage drop		Residual current protection down to 0 V according to IEC/EN 61008-1 § 3.3.4
According to IEC/EN 60947-2		
Ultimate breaking capacity (Icu)	6 kA	15 kA
Service breaking capacity (Ics)	100 % of Icu	50 % of Icu
Additional characteristics		
Degree of protection	Device only	IP20
	Device in modular enclosure	IP40
Endurance (O-C)	Electrical	10,000 cycles
	Mechanical	20,000 cycles
Overvoltage category (IEC 60364)		III
Operating temperature		-25°C to +60°C
Storage temperature		-40°C to +70°C
Range of test button operating voltage	2P	-
	3P	195.5...253 V AC
	4P	195.5...253 V AC
Tropicalization		Treatment 2 (relative humidity 95 % to 55°C)

Weight (g)

Residual current device	
Type	iC60 RCBO
2P	234
3P	334
4P	445

Residual current device iC60 RCBO (cont.)

Tripping curves

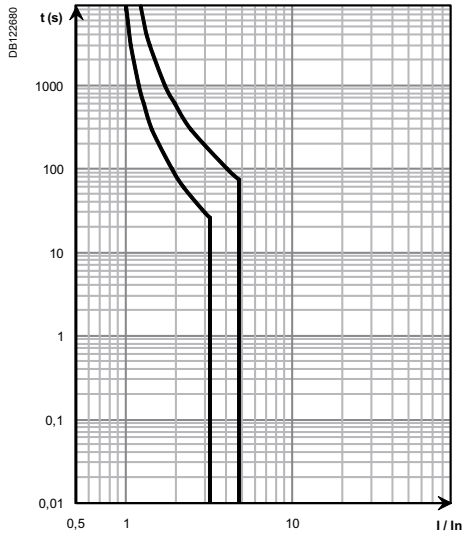

B curve

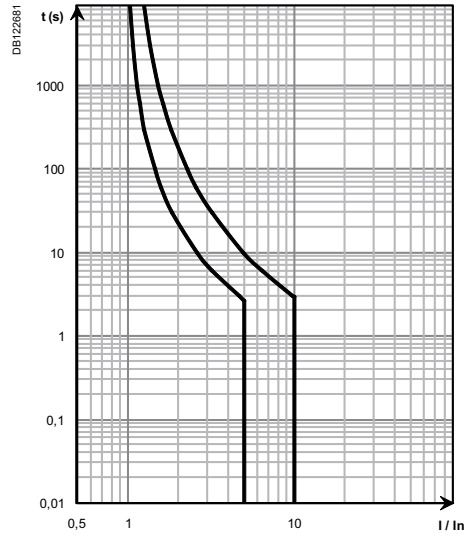

C curve

Peak limitation curves

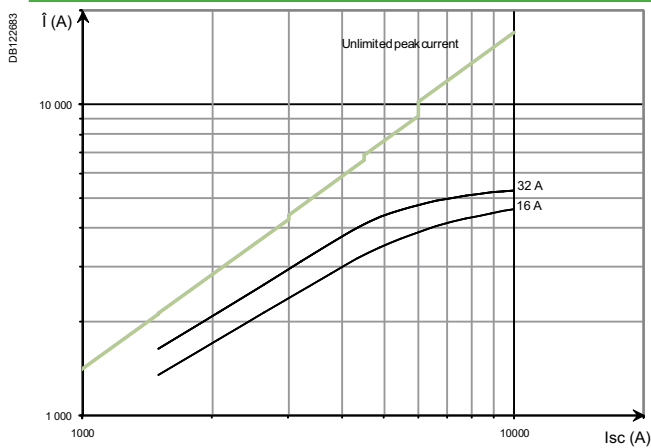

iC60 RCBO 10000 A - 2P/3P - 230 V

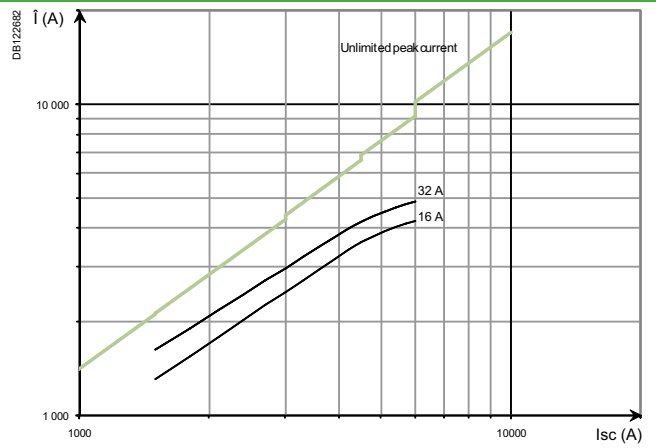

iC60 RCBO 6000 A - 3P/4P - 400 V

Energy curves

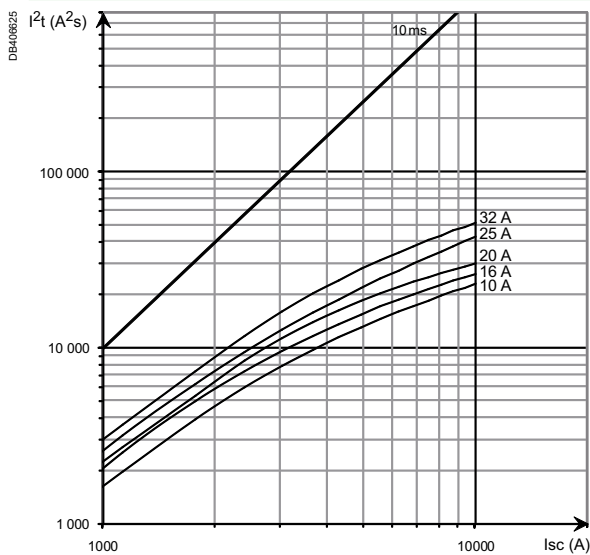

iC60 RCBO 10000 A - 2P/3P - 230 V

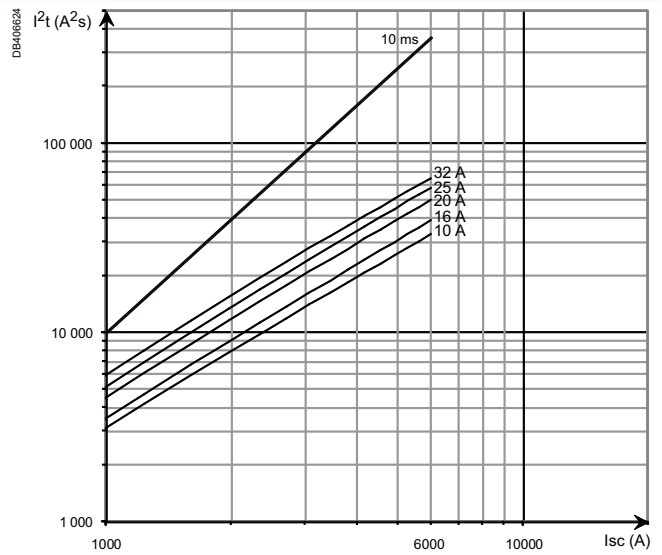

iC60 RCBO 6000 A - 3P/4P - 400 V

Protection

Earth leakage protection

Automatic recloser

REDs, REDtest



IMQ only for REDs, cat. no. 18264, 18265, 18266, 18267, 18268, 18269, 18687 and 18689

Country approval pictogram



REDs 2P

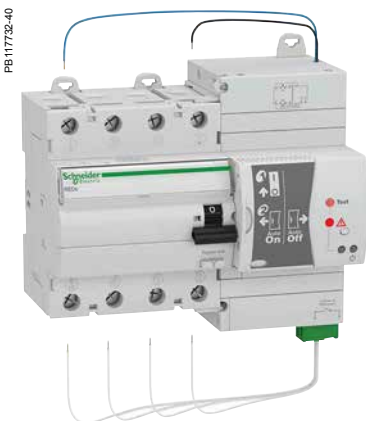

REDs 4P



REDtest

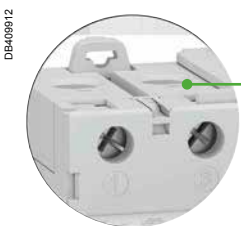

■ REDs 2P, 4P: supply from above or below

EN 50557

The REDs and the REDtest, **RE**sidual current **D**evice recloser, is made up of a residual current device and a recloser.

The **REDs** and **REDtest RESidual current Devices** offer the following functions:

- protection of people against direct and indirect contacts
- protection of installations against insulation faults
- disconnection of on-load electric circuits, already protected against overloads and short-circuits
- automatic restart after insulation monitoring of the downstream circuit.

REDtest provides the following additional functions:

- automatic and periodical test of the device, without breaking downstream circuit (REDtest).

Only used on TT and TN-S earthing grounding systems.

Residual current circuit breakers	2P	4P
Making and breaking capacity, rated residual current ($I\Delta m = I_m$)	630 A	630 A

Catalogue numbers

REDs residual current circuit breakers REDs

A type				Width in mod. of 9 mm
2P	Sensitivity	30 mA	300 mA	

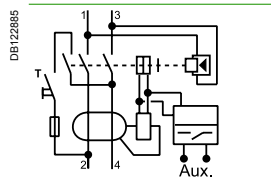

Rating	25 A	18687	18688	8
	40 A	18689	18690	
	63 A	18691	18692	

Voltage rating (Ue)	230 V		
Frequency rating	50Hz		

4P	Sensitivity	30 mA	300 mA	
Rating	25 A	18264	18265	14
	40 A	18266	18267	
	63 A	18268	18269	
	100 A	-	18270	

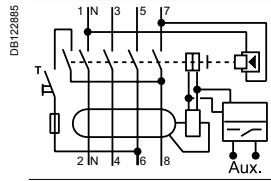

Voltage rating (Ue)	400 V		
Frequency rating	50 Hz		

REDtest residual current circuit breakers

A type				Width in mod. of 9 mm
2P	Sensitivity	30 mA		

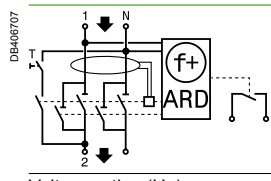

Rating	25 A	18280		10
	40 A	18281		

Voltage rating (Ue)	230 V		
Frequency rating	50 Hz		

Protection

Earth leakage protection

Automatic recloser

REDs, REDtest (cont.)

Coordination table, max short-circuit current (kA rms)

Circuit-breakers, fuse / A type REDs, REDtest coordination

Upstream		Circuit-breakers										Fuses			
Downstream		DPN	DPN N	iC60N / C120N				iC60H, L / C120H, L / NG125N, H, L				gG			
Products	Ratings (A)	0.5 to 40	0.5 to 40	0.5 to 25	32 - 40	50 - 63	80 - 100	0.5 to 25	32 - 40	50 - 63	80 - 100	gG 25	gG 40	gG 63	gG 100
REDs Type A 2P															
	25	6	10	10	-	-	-	10	-	-	-	10	-	-	-
	40	6	10	10	10	-	-	15	10	-	-	15	10	-	-
	63	-	-	10	10	10	-	15	15	10	-	25	15	10	-
REDs Type A 4P															
	25	6	10	10	-	-	-	10	-	-	-	10	-	-	-
	40	6	10	10	10	-	-	15	10	-	-	15	10	-	-
	63	-	-	10	10	10	-	15	10	10	-	25	15	10	-
	100	-	-	10	10	10	10	15	15	15	10	25	25	15	10
REDtest Type A 2P															
	25	6	6	6	-	-	-	6	-	-	-	6	-	-	-
	40	6	6	10	6	-	-	10	6	-	-	10	6	-	-

DB122893

		Circuit-breaker (MCB) or Fuse (FU)			
		≤ 25 A	≤ 40 A	≤ 63 A	≤ 100 A
REDs / REDtest	25 A	■	—	—	—
	40 A	■	■	—	—
REDs	63 A	■	■	■	—
	100 A	■	■	■	■

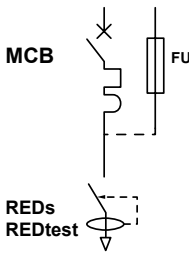

Operation

REDs

The REDs operates in the residual current device mode, without automatic restart, when the sliding cover is open, i.e. to the right in the Auto Off position (Fig. 1).

The automatic restart mode and the Autotest are activated, when the sliding cover is closed, i.e. to the left in the Auto On position (Fig. 2).

Test

! This is only possible in manual mode, i.e. sliding cover open in the Auto Off position. You can then manually test the device by pressing the Test key. The downstream installation is then temporarily broken. You must then manually reclose the RED by activating the O-I lever to power supply the downstream circuit.

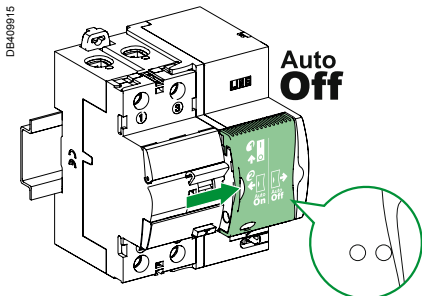

Fig. 1

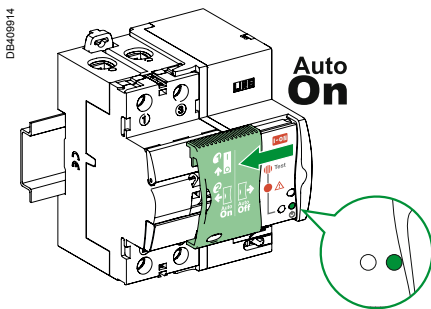

Fig. 2

REDtest

■ The REDtest carries out automatic testing of earth leakage protection every months.

The test consists in opening and reclosing the REDtest, during which time continuity of supply of the downstream installation is guaranteed.

Autotest: after checking installation insulation, the REDtest monitors its residual current device, without breaking the downstream power supply (bypass by bypass contact).

Protection
 Earth leakage protection
 Automatic recloser
REDs, REDtest (cont.)

Operation ON mode: temporary network fault
 REDs, REDtest

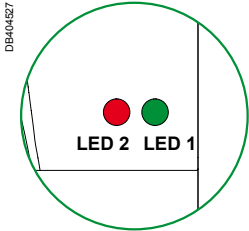

(*) Reclosing time:
 REDtest 2P: 10 s
 REDs 2P: 90 s
 REDs 4P: 10 s

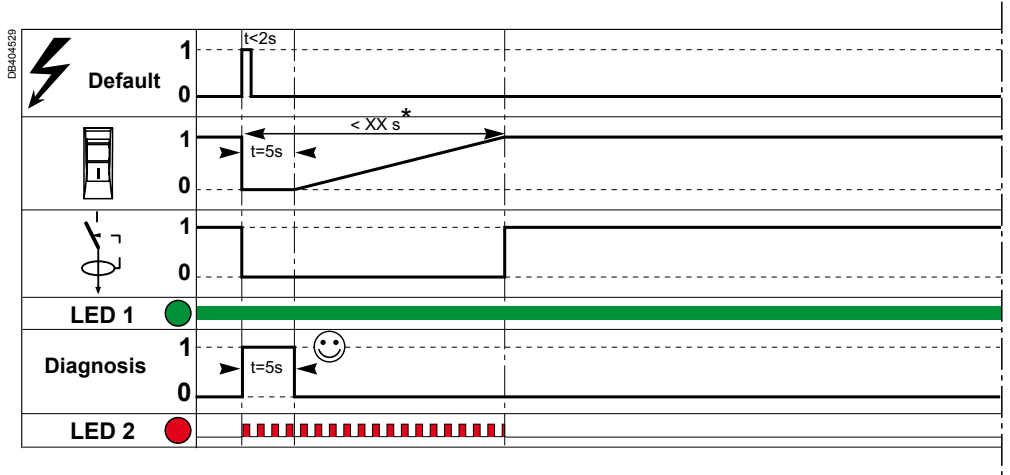

The built-in automatic recloser automatically recloses the residual current device after checking insulation of the downstream circuit.
 Rd: lower level of insulation resistance, if $R < R_d$ = no reclose
 Rdo: higher level of insulation resistance, if $R_d > R_{do}$ = reclose

Operation ON mode: long network fault

REDs

If the circuit is faulty, the switch is prohibited from reclosing. After a time delay of 2 minutes, the downstream circuit insulation is rechecked.

There are then two possibilities:

- the installation is still faulty (the resistance to earth is lower than Rd): in this case a new check will be carried out in 2 minutes.
- the fault was temporary and has disappeared (the resistance to earth is higher than Rdo): the recloser automatically recloses the REDs.

$I_{\Delta n}$	30 mA	300 mA
Rd	16 kΩ	5 kΩ
Rdo	8 kΩ	2.5 kΩ

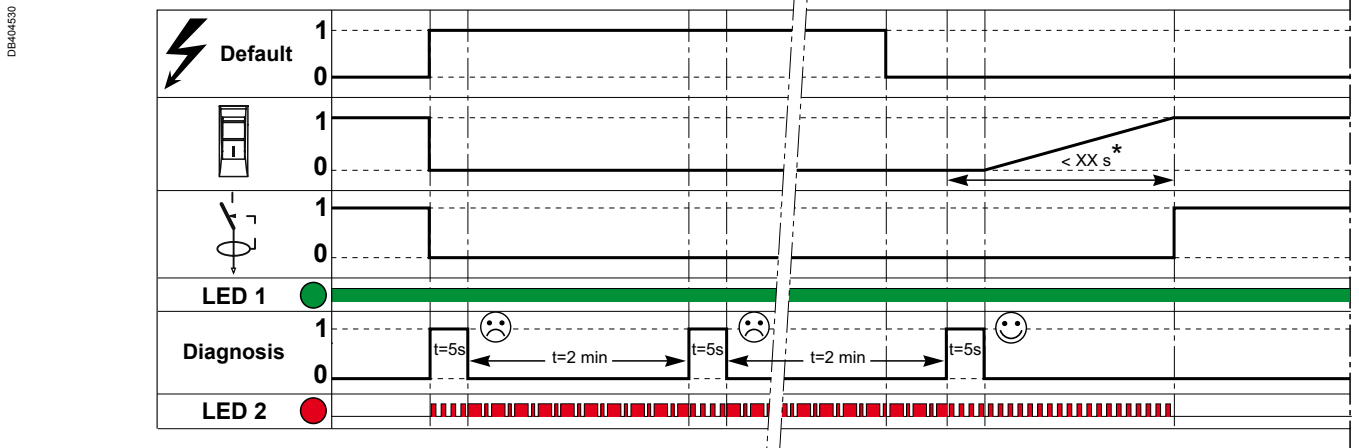

(*) Reclosing time:
 REDs 2P: 90 s
 REDs 4P: 10 s

Operation ON mode: long network fault (cont.)

REDtest

If the circuit is faulty for a length of time "greater than 5 seconds", the switch is prohibited from reclosing.

- The installation is faulty: the earth resistance is lower than R_d .

$I_{\Delta n}$	30 mA
R_d	70 k Ω
R_{do}	20 k Ω

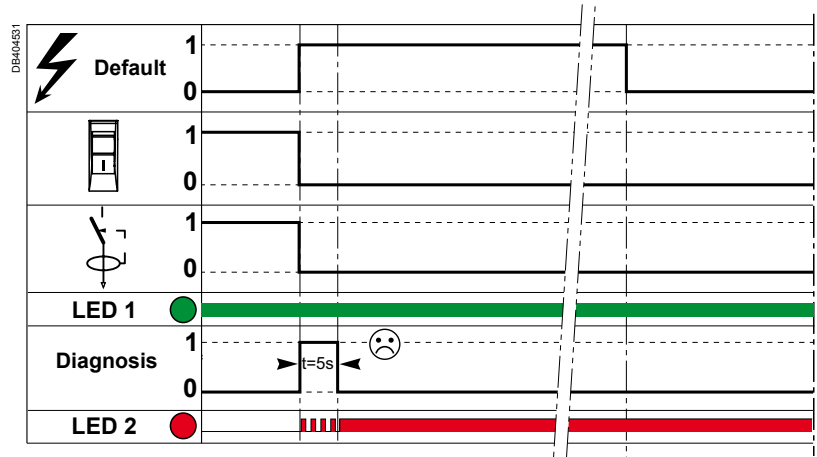

Connection

Type	Tightening torque	Copper cables	
		Rigid	Flexible or with ferrule
 PZ1 / PZ2	2 N.m	 35 mm ²	 35 mm ²
 + PZ0	0.4 N.m	2.5 mm ²	2.5 mm ²
 + PZ0	0.4 N.m	2.5 mm ²	2.5 mm ²
	0.5 N.m	2.5 mm ²	2.5 mm ²

Connection by tunnel terminal with guard

Protection

Earth leakage protection

Automatic recloser

REDs, REDtest (cont.)

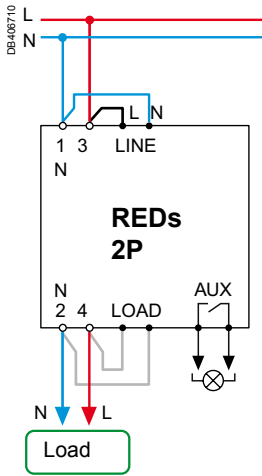

Wiring of non-polarized white wires

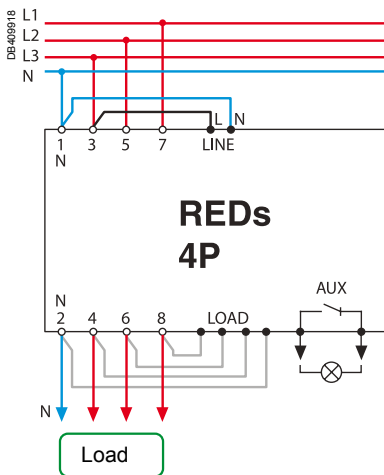
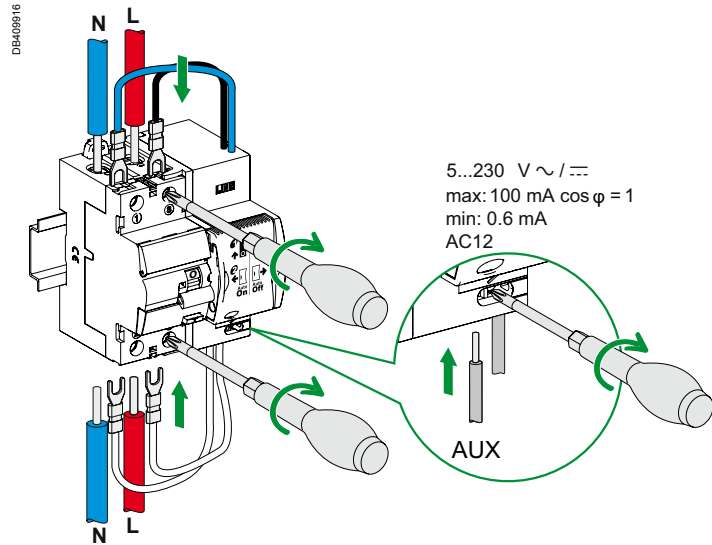

Wiring of non-polarized white wires

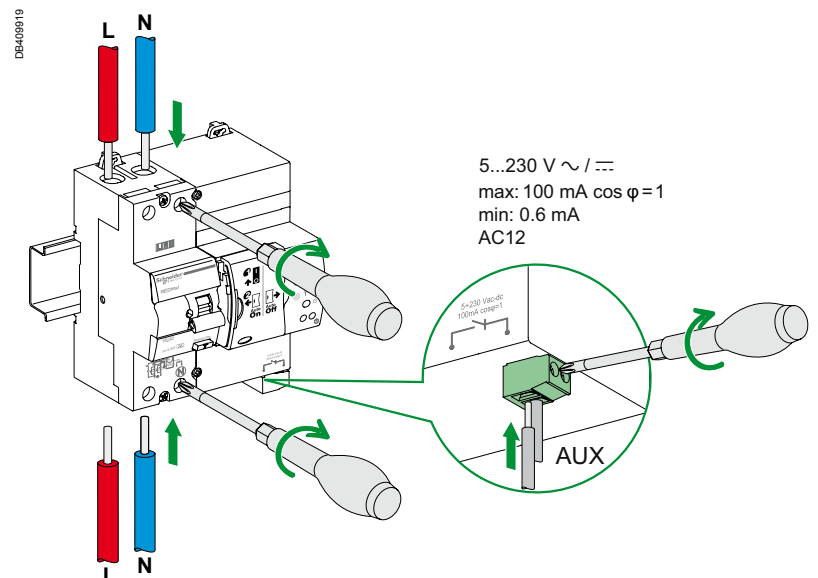
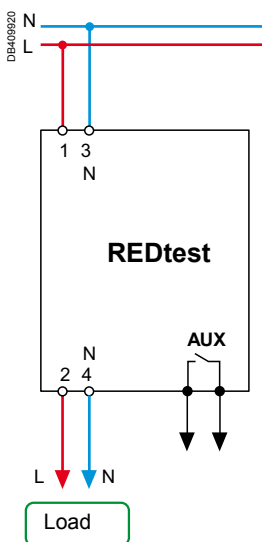
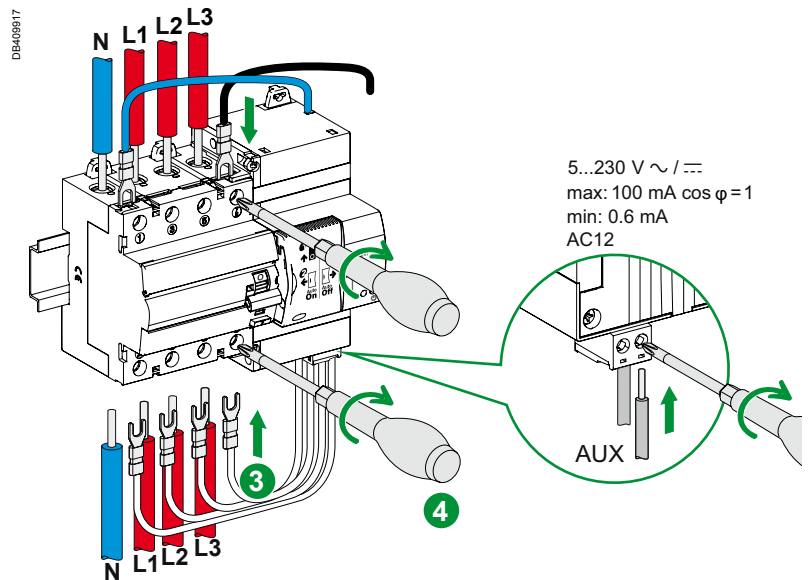

Protection

Earth leakage protection

Automatic recloser

REDs, REDtest (cont.)

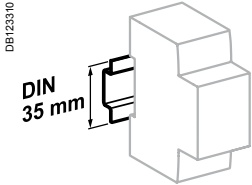

Clip on DIN rail 35 mm.

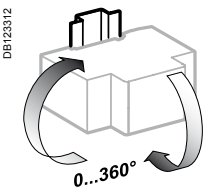

Indifferent position of installation.

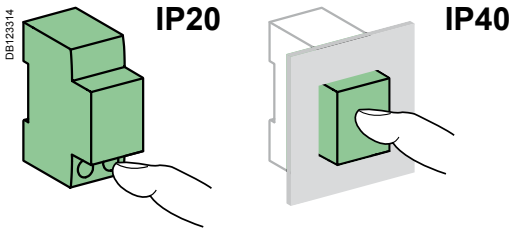

Technical data.

Main characteristics	2P		4P
Common technical data	REDtest	REDs	REDs
Earthing grounding systems	TT and TN-S only		
Impulse withstand voltage (U _{imp})	4 kV		
Insulation voltage (U _i)	500 V		
8/20 μs wave immunity level	250 A		
Tropicalization	Treatment 2 (relative humidity: 95 % at 55°C)		
Operating temperature	-5°C to +40°C		
Storage temperature	-20°C to +60°C		
Protection class	IP20 at terminals		
Additional characteristics			
Residual current device			
Tripping time	ΔI _n : ≤ 300 ms 5 ΔI _n : ≤ 40 ms		
Number of cycles (O-C)	1 000		4 000
Fixed sensitivity releases for all ratings	Instantaneous release		
Test button min operating voltage	195 V	100 V	170 V
Behaviour in case of voltage drop	Residual current protection down to 0 V according to IEC/EN 61008-1 § 3.3.4		
Recloser			
Max duration of a restart cycle	< 10 s	< 90 s	< 10 s
Maximum number of consecutive restart attempts (if no earth fault)	3		
Min interval between 2 closings	180 s		30 s
Insulation fault presence monitoring	Yes		
Insulation fault diagnosis	If fault: stopping of the restart cycle	If fault: diagnosis every 2 minutes with stopping of the restart cycle	
Stopping restart cycle if insulation fault present	Yes	Yes, during 15 minutes	
Not operating resistance to earth (R _d)	20 kΩ	8 kΩ (30 mA), 2.5 kΩ (300 mA)	
Operating resistance to earth (R _{do})	70 kΩ	16 kΩ (30 mA), 5 kΩ (300 mA)	
Power consumed by the electronics	8 VA	0 VA	
Indication			
Status indication	Mechanical: by O-I (open-closed) 2-position lever ■ Electrical: by 2 indicator lights on the front panel: □ left: red/yellow LED □ right: green LED Remote: by 1 built-in auxiliary contact		
Auxiliary contact			
Voltage rating (U _e)	5...230 V AC/DC		
Insulation voltage (U _i)	350 V		
Current rating (I _n)	Min: 0.6 mA Max: 100 mA, power factor = 1		
Utilization category	AC12		
Type	Configurable	NO or NC	Intermittent 1 Hz/30 s or NO or NC
Connection by tunnel terminal	Flexible or rigid cable: max 2.5 mm ²		

Protection
 Earth leakage protection
 Automatic recloser
REDs, REDtest (cont.)

Weight (g)

Reclosers	2P	4P
REDs	330	<ul style="list-style-type: none"> ■ 25/40 A: 630 ■ 63 A: 650 ■ 100 A: 650
REDtest	370	-

Dimensions (mm)

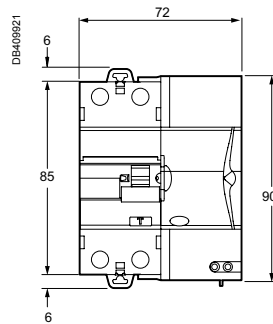

REDs 2P

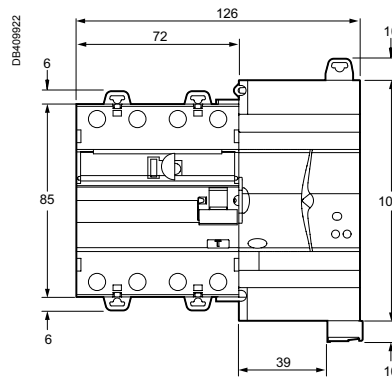

REDs 4P

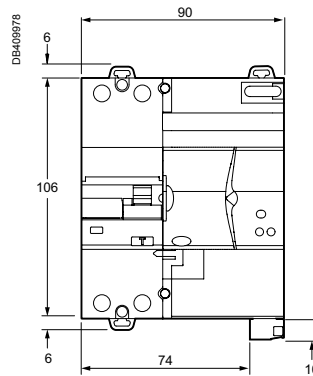

REDtest

Protection / Circuit protection

Arc fault detection circuit breaker iDPN N Arc



The iDPN N Arc is an arc fault detection device with protection against overload and short-circuit currents, which aims to reduce the risk of electrical fire.

By continuously analyzing a large number of electrical parameters, it detects the appearance of electric arcs that are responsible for starting fires. It isolates the circuit concerned which reduces flame appearance occurrence.

The European installation standard IEC 60364-4-42, recommends the use of AFDD to protect against arc fault in final circuit:

- in locations with sleeping accommodations (e.g., hotels, nursing homes, bedrooms in homes)
- in locations with risks of fire due to high quantities of flammable materials (e.g., barns, wood-working shops, stores of combustible materials)
- in locations with combustible constructional materials (e.g., wooden buildings)
- in fire propagating structures (e.g. high rise buildings)
- in locations where irreplaceable goods are housed (e.g., museums).

More specifically, the installation of iDPN N Arc is highly recommended to protect circuits with highest risk of fire, such as:

- protruding cables (risk of knocks)
- outside cables (greater risk of deterioration)
- unprotected cables in secluded areas (like storage rooms)
- aging, deteriorating wiring or wiring for which the connection boxes are inaccessible.

iDPN N Arc must not be installed on circuits requiring high level of continuity of service.

The iDPN N Arc is not compatible with ATEX regulations.

IEC 60898-1

Circuit breakers for the protection against the overload (residential and similar installations).

IEC/EN 62606

General requirements for arc detection devices.

- In addition to protection against overloads and short circuits, the iDPN N Arc monitors for electric arcs that occur in cables and connections, that may cause a fire. These arcs are the result of localised cable deterioration or loose connections.
- It is used for three types of situations that can result in a fire:
 - parallel arc: insulation problems between two live conductors that cause a resistive short-circuit, too weak to be detected by a circuit breaker and with no earth leakage to be detected by a residual current circuit breaker,
 - series arc: a damaged conductor or connection that causes part of the current to flow through its carbonised insulation due to a local rise in temperature,
 - overheating of electronic components in loads, when exposed to an overvoltage for several seconds.
- It combines the following functions:
 - circuit protection against overload and short-circuit currents (circuit breaker function),
 - protection against fire hazards by detection of abnormal electric arcs,
 - protection against load fire hazards due to slow overvoltages (network overvoltage),
 - fire hazard tripping indication via the front panel indicator,
 - device self-diagnostics via the test button,
 - positive contact indication (green strip).
- The iDPN N Arc should be installed in the place of the circuit's final protection device.

Catalogue numbers

iDPN N Arc 6000			
Arc Fault Detection Devices (AFDD) to IEC/EN 62606			Width in 9 mm modules
1P+N		B curve	C curve
	Rating (In)	6 A	A9FDB606
		10 A	A9FDB7610
		13 A	A9FDB7613
		16 A	A9FDB7616
		20 A	A9FDB620
		25 A	A9FDB625
Operating voltage	230 V AC		
Operating frequency	50 Hz		

Connection

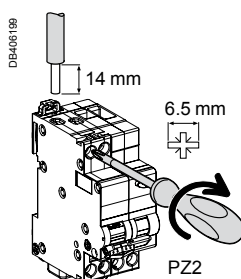

Tightening torque	Copper cables only	
	Rigid	Flexible or with ferrule
2 N.m	 1 x 1 to 16 mm ² 2 x 1 to 2.5 mm ²	 1 x 1 to 10 mm ² 2 x 1 to 2.5 mm ²

Arc fault detection circuit breaker iDPN N Arc (cont.)



FB110631-50



Test button
■ For device self-diagnostic

Positive contact indication
■ A green strip on the handle indicates that all the poles are open for insulation

Red square indicator
■ Fire hazard tripping indication via a "red" status indicator

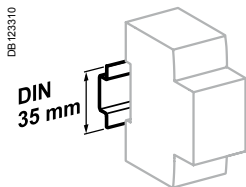

Clip on DIN rail 35 mm.

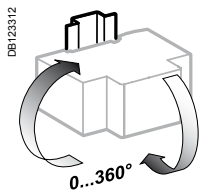

Indifferent position of installation.

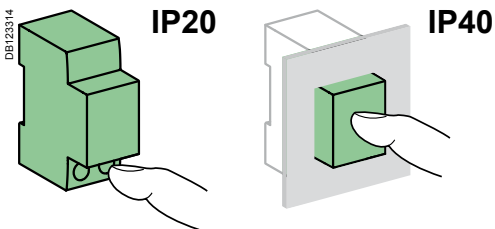

Technical data

Main characteristics						
Tripping time/arc current value with $U_n = 230$ V AC (to IEC/EN 62606)	Arc current	2.5 A	5 A	10 A	16 A	25 A
	Max. operating time	1 s	0.5 s	0.25 s	0.15 s	0.14 s
Overvoltage tripping time (neutral conductor break)		400 V AC, 200 ms				
Insulation voltage (U_i)		400 V AC				
Degree of pollution		2				
Rated impulse withstand voltage (U_{imp})		4 kV				
Overvoltage category		III				
Limitation class		3				
Thermal tripping	Reference temperature	30°C				
Magnetic tripping	Curve B	Between 3 and 5 I_n				
	Curve C	Between 5 and 10 I_n				
Rated breaking capacity (I_{cn})		6 000 A				
Additional characteristics						
Degree of protection	Device alone	IP20				
	Device in a modular enclosure	IP40 Insulation class II				
Endurance (O-C)	Electrical	≤ 20 A	20,000 cycles			
		25 A	10,000 cycles			
	Mechanical	20,000 cycles				
Operating temperature		-25°C to +60°C				
Storage temperature		-40°C to +85°C				
Tropicalization (to IEC/EN 62606)		Severity B (to IEC 60068-2-30) during 28 days				

Weight (g)

Arc fault detection circuit breaker	
Type	iDPN N Arc
1P+N	198

Dimensions (mm)

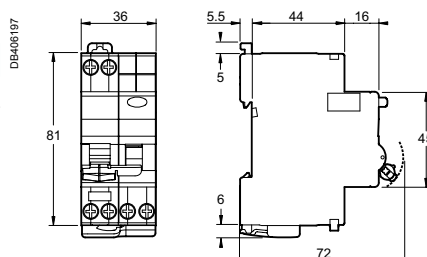

Protection

Load protection

iPRF1 12.5r/PRD1 35r/PRD1 25r/PRD1 Master Type 1 and 2 LV surge arresters

The Type 1 range of surge arresters meets the normative withstand capability of current wave type 10/350 μ s (8/20 μ s for Type 2 surge arresters).

It is suitable for use with TT, TN-S, TN-C and IT earthing connection systems (neutral point connection).

In addition, the PRD1 35r surge arrester covers the 400 V IT system.

iPRF1 12.5r and PRD1 surge arresters are fitted with a remote transfer contact to send "end-of-life indication" information.

PRD1 surge arresters are fitted with easy-to-replace withdrawable cartridges.

iPRF1 12.5r/PRD1 35r/PRD1 25r/PRD1 Master

The Type 1 surge arrester is recommended for electrical installations in the service sector and industrial buildings protected by a lightning conductor or by a meshed cage.

It protects electrical installations against direct lightning strikes.

It is used to conduct the direct lightning current, propagating from the earth conductor to the network conductors.

It must be installed with an upstream disconnection device, such as a fuse or circuit-breaker, whose breaking capacity must be at least equal to the maximum prospective short-circuit current at the installation point.

iPRF1 12.5r and PRD1 25r surge arresters also provide Type 2 protection and protect the electrical installation by finely clipping the lightning wave overvoltages.



iPRF1 12.5r (3P+N)

PRD1 35r (1P)



PRD1 25r (3P+N)



PRD1 Master (3P+N)

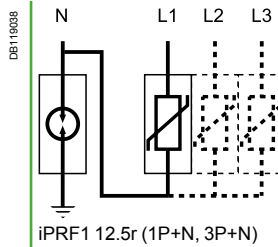

Type	Product solution	
------	------------------	--

Fixed surge arrester	1P+N	3P+N
----------------------	------	------

iPRF1 12.5r T1, T2	A9L16632	A9L16634
-----------------------	----------	----------

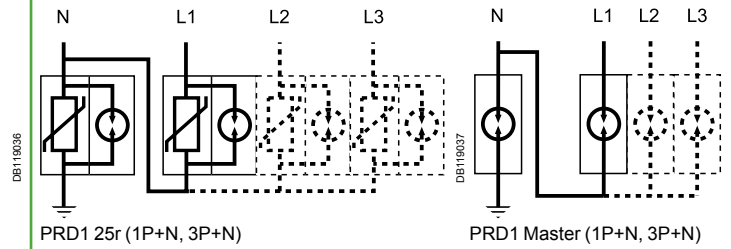

Cartridge surge arrester	1P+N	3P+N
--------------------------	------	------

PRD1 25r T1 + T2	16330	16332
---------------------	-------	-------

PRD1 Master T1	16361	16363
-------------------	-------	-------

PRD1 35r T1		
----------------	--	--

Protection
Load protection

iPRF1 12.5r/PRD1 35r/PRD1 25r/PRD1 Master
Type 1 and 2 LV surge arresters (cont.)

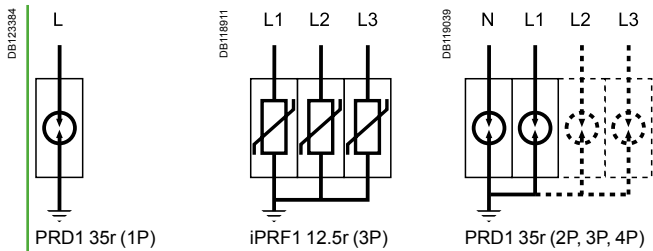

				Earthing system	Recommended accessory
1P	2P	3P	4P	TT, TN-S	
		A9L16633		TN-C	

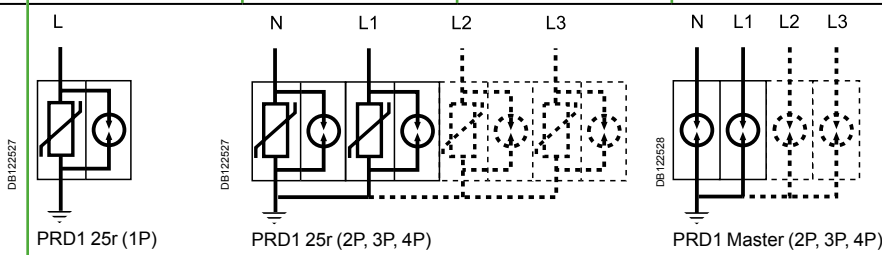

				Earthing system	Recommended accessory
1P	2P	3P	4P	TT, TN-S	
16329	2 x 16329		4 x 16329	TT, TN-C	
		16331		TN-C	
				TT, TN-S	
16360	2 x 16360		4 x 16360	TT, TN-C	
		16362		TN-C	
	2 x 16649			IT distributed neutral, TT, TN-S	16643
16649		3 x 16649		IT non-distributed neutral, TN-C	16644
			4 x 16649	IT distributed neutral	16645

iPRF1 12.5r/PRD1 35r/PRD1 25r/PRD1 Master Type 1 and 2 LV surge arresters (cont.)

Type	Nb. of poles	Width modules	I imp (kA) (10/350) Impulse current	I max (kA) (8/20) Maximum discharge current	In - kA Nominal discharge current	Up - kV Voltage protection level	Un - (V) Rated voltage network	Uc - V Maximum continuous operating voltage (L-N)/(N-PE)	Cat. no.
Fixed surge arrester		9 mm modules							
iPRF1 12.5r	Type 1 + 2								
	1P+N	4	12.5 (L-N)/50 (N-PE)	50	25	≤ 1.5	230	350/255	A9L16632
	3P	8	12.5	50	25	≤ 1.5	230/400	350	A9L16633
	3P+N	8	12.5 (L-N)/50 (N-PE)	50	25	≤ 1.5	230/400	350/255	A9L16634
Withdrawable surge arrester									
PRD1 25r	Type 1 + 2								
	1P	4	25	40	25	≤ 1.5	230	350	16329
	1P+N	8	25 (L-N)/100 (N-PE)	40	25	≤ 1.5	230	350/350	16330
	3P	12	25	40	25	≤ 1.5	230/400	350	16331
	3P+N	16	25 (L-N)/100 (N-PE)	40	25	≤ 1.5	230/400	350/350	16332
PRD1 Master	Type 1								
	1P	4	25	50	25	≤ 1.5	230	350	16360
	1P+N	8	25 (L-N)/100 (N-PE)	50	25	≤ 1.5/2.5	230	350/350	16361
	3P	12	25	50	25	≤ 1.5	230/400	350	16362
	3P+N	16	25 (L-N)/100 (N-PE)	50	25	≤ 1.5/2.5	230/400	350/350	16363
PRD1 35r	Type 1								
	1P	4	35	50	35	≤ 2.5	400/690 (TN) 400 (IT)	440	16649
Spare cartridge									
C1 Master-350	-	4	-	-	25	≤ 1.5	-	350	16314
C1 25-350	-	23 mm	-	-	25	≤ 1.5	-	350	16315
C2 40-350	-	12 mm	-	-	20	≤ 1.5	-	350	16316
C1 Neutral-350	-	4	-	-	-	-	-	350	16317
C1 35-440	-	4	-	-	35	≤ 2.5	-	440	16318

PE1042618-30



C1 Neutral-350

DB12370



Surge arresters	Spare cartridge		
	Phase		Neutral
	Type 1	Type 2	
PRD1 25r			
PRD1 25r 1P	16315	16316	-
PRD1 25r 1P+N	16315	16316	16317
PRD1 25r 3P	3 x 16315	3 x 16316	-
PRD1 25r 3P+N	3 x 16315	3 x 16316	16317
PRD1 Master			
PRD1 Master 1P	16314	-	-
PRD1 Master 1P+N	16314	-	16317
PRD1 Master 3P	3 x 16314	-	-
PRD1 Master 3P+N	3 x 16314	-	16317
PRD1 35r			
PRD1 35r 1P	1 x 16318	-	-
PRD1 35r 2P	2 x 16318	-	-
PRD1 35r 3P	3 x 16318	-	-
PRD1 35r 4P	4 x 16318	-	-

Accessories

Type	Number of poles (18 mm)	
Wiring comb busbars for 2 x 1P	4	16643
Wiring comb busbars for 3 x 1P	6	16644
Wiring comb busbars for 4 x 1P	8	16645
200 mm flexible cable	-	16646

iPRF1 12.5r/PRD1 35r/PRD1 25r/PRD1 Master Type 1 and 2 LV surge arresters (cont.)

Technical data

		iPRF1 12.5r	PRD1 35r	PRD1 25r	PRD1 Master
Operating frequency		50 Hz	50/60 Hz	50 Hz	50 Hz
Degree of protection	Front panel	IP40	IP40	IP40	IP40
	Terminals	IP20	IP20	IP20	IP20
	Impacts	IK05	IK05	IK05	IK05
Response time		≤ 25 ns	≤ 100 ns	≤ 25 ns	≤ 100 ns
Short circuit withstand (I _{scsr})		50 kA	50 kA	25 kA	50 kA
Temporary overvoltage withstand (U _T)	U _T (L-N)	335 V AC/5 s	580 V AC/5 s	415 V AC/5 s	415 V AC/5 s
	U _T (N-PE)	1200 V AC/200 ms	800 V AC/120 min	1200 V AC/200 ms	1200 V AC/200 ms
Temporary overvoltage Safe failure mode (U _T)	U _T (L-N)	440 V AC/120 min	1640 V AC/200 ms	440 V AC/120 min	440 V AC/120 min
Ground residual current (I _{PE})	I _{PE} (N-PE)	0.004 mA	≤ 0.005 mA	≤ 0.01 mA for 1P+N, 3P+N	≤ 0.01 mA for 1P+N, 3P+N
Follow current interrupting rating (I _f)	I _f (L-N)	-	50 kA	25 kA/264 V AC 3 kA/350 V AC	50 kA
	I _f (N-PE)	100 A	-	100 A	100 A
End-of-life indication		Green: correct operation Red: at end of life	White: correct operation Red: at end of life	White: correct operation Red: at end of life	White: correct operation Red: at end of life
	Remote notification	1.5 A/250 V AC	1 A/250 V AC ≤ 1 A/30 V DC	1 A/250 V AC ≤ 1 A/30 V DC	1 A/250 V AC ≤ 1 A/30 V DC
By tunnel terminal	Rigid cable	10...35 mm ²	16...35 mm ²	10...35 mm ²	10...35 mm ²
	Flexible cable	10...25 mm ²	10...25 mm ²	10...25 mm ²	10...25 mm ²
Operating temperature		-25°C to +60°C	-40°C to +80°C	-40°C to +80°C	-40°C to +80°C
Humidity range		5 % to 95 %	5 % to 95 %	5 % to 95 %	5 % to 95 %
Standards		IEC 61643-11: 2011 T1 , T2 EN 61643-11: 2012 Type 1 + Type 2	IEC 61643-11 T1 EN 61643-11 Type 1	IEC 61643-11: 2011 T1 , T2 EN 61643-11: 2012 Type 1 + Type 2	IEC 61643-11: 2011 T1 EN 61643-11: 2012 Type 1
Approvals		CE, EAC	CE	CE, KEMA-KEUR	CE, KEMA-KEUR

Choice of disconnector / surge arrester

Type	I imp: impulse current	Isc: prospective short-circuit current at the installation point				
		10 kA		15 kA	25 kA	36 kA
iPRF1 12.5r	12.5 kA	C120N 80 A curve C or Compact NSX100B 100 A *	C120H 80 A curve C or Compact NSX100B 100 A *	NG125N 80 A curve C or Compact NSX100B 100 A *	NG125H 80 A curve C or Compact NSX100F 100 A *	NG125L 80 A curve C or Compact NSX100N 100 A *
PRD1 35r	35 kA	Compact NSX160B 160 A			Compact NSX160F 160 A	Compact NSX160N 160 A
PRD1 25r	25 kA	Compact NSX100B 100 A			-	
PRD1 Master	25 kA	Compact NSX100B 100 A			Compact NSX100F 100 A	Compact NSX100N 100 A

(*) For lightning impulse current withstand

PR113736-90

PRD1 25r / PRD1 Master / PRD1 35r Reversible

■ The surge arrester base can be turned over to allow the phase/neutral/earth cables to enter through either the top or the bottom

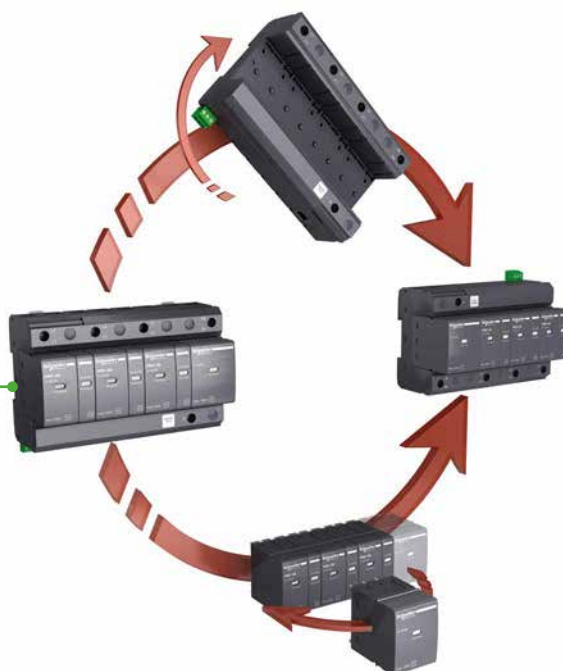

Protection
Load protection

iPRF1 12.5r/PRD1 35r/PRD1 25r/PRD1 Master
Type 1 and 2 LV surge arresters (cont.)

Dimensions (mm)

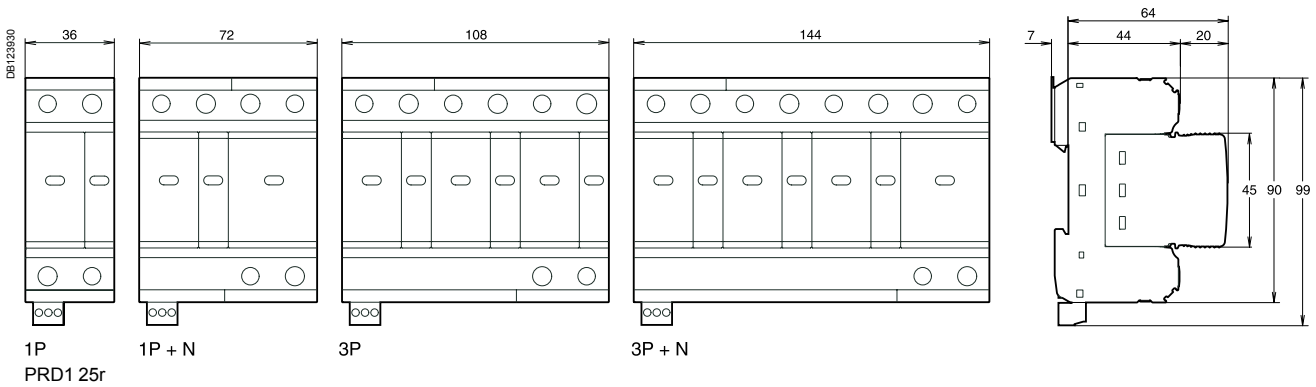
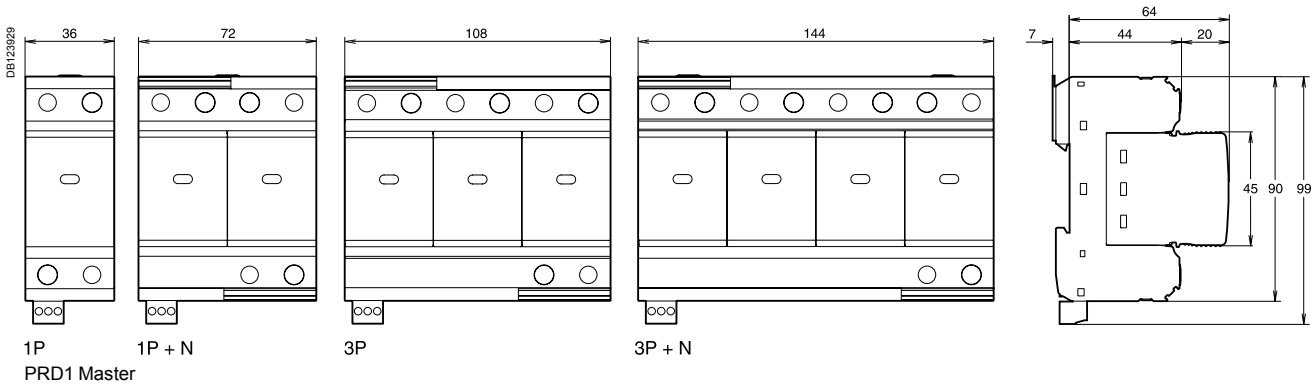
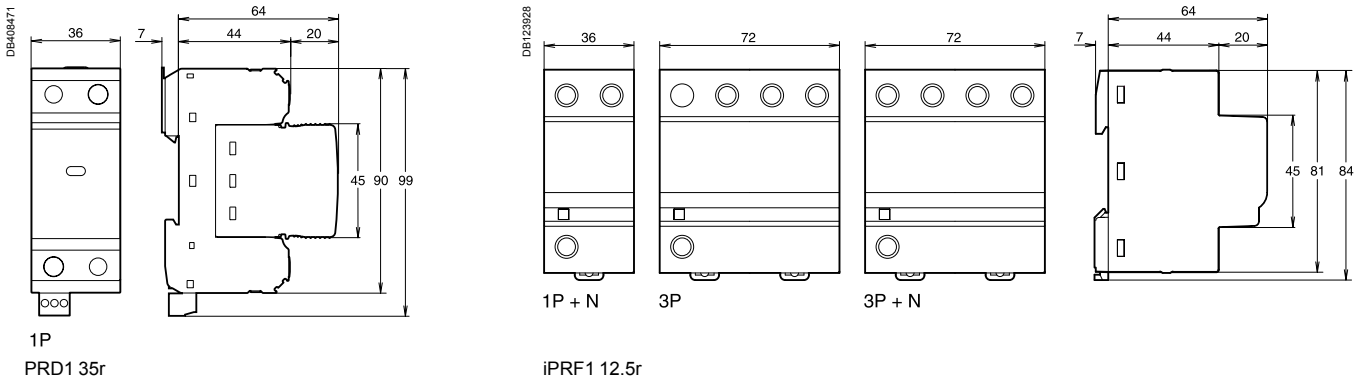

Weight (g)

Surge arresters				
Type	iPRF1 12,5r	PRD1 35r	PRD1 25r	PRD1 Master
1P	-	401	334	394
1P+N	290	-	725	774
3P	590	-	1010	1175
3P+N	590	-	1338	1535
Cartridge	Neutral	-	229	229
	Phase	-	-	242

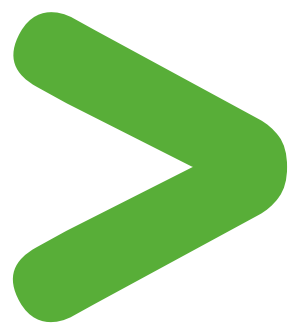

Protection Load protection

iPF surge arresters Type 2 or 3 LV surge arresters

The iPF multi-pole single-piece surge arrester range is adapted for earthing systems: TT, TN-S, TN-C.

Type 2 surge arresters are tested with a 8/20 μ s current wave.

Type 3 surge arresters are tested with a 12/50 μ s and 8/20 μ s combined wave.

Each surge arrester in the range has a specific application:

- **incoming protection (type 2):**
 - the iPF65(r) is recommended for a very high risk level (strongly exposed site)
 - the iPF40(r) is recommended for a high risk level
 - the iPF20 is recommended for a medium risk level
- **secondary protection (type 2 or 3):**
 - the iPF8 ensures secondary protection of loads to be protected and is placed in cascade with the incoming surge arresters. This surge arrester is required when the loads to be protected are at a distance of more than 10 m from the incoming surge arrester.

The iPF surge arresters with “r” indication have remote transfer of the information: “surge arrester to be replaced”.



1P+N.



3P+N.

Rated discharge current (I _{max}) / Nominal discharge current (I _n)	Type of protection		Network							
	Incoming	Secondary (type 2 or 3)	1P+N	3P+N	1P	2P	3P	4P		
65 kA / 20 kA										
Very high risk level	iPF65				A9L15683					
			A9L15684				A9L15584			
									A9L15581	
						A9L15685				
						A9L15586				
										A9L15585
40 kA / 15 kA										
High risk level	iPF40				A9L15686					
			A9L15687				A9L15587			
									A9L15582	
						A9L15690				
						A9L15688				
										A9L15590
								A9L15588		
20 kA / 5 kA										
Medium risk level	iPF20				A9L15691					
			A9L15692				A9L15592			
									A9L15597	
						A9L15693				
								A9L15593		
8 kA / 2.5 kA										
Secondary protection: placed near the loads to be protected when they are at a distance of more than 10 m from the incoming surge arrester		iPF8								

Surge arrester/circuit breaker association	
Type of surge arrester	Associated circuit breaker
iPF65	Curve C 50 A
iPF40	Curve C 40 A
iPF20	Curve C 25 A
iPF8	Curve C 20 A

Protection

Load protection

iPF surge arresters

Type 2 or 3 LV surge arresters (cont.)

	Earthing system	Transfer	Surge arrester name	Width in mod. of 9 mm	Up - (kV) Voltage protection level			Un - (V) Rated voltage network	Uc - (V) Maximum continuous operating voltage		
					CM*		DM*		CM*		DM*
					L/±	N/±	L/N		L/±	N/±	L/N
iPF65											
	TT & TN		iPF65 1P	2	≤ 1.5	-	-	230	340	-	-
	TT & TN-S		iPF65 1P+N	4	-	≤ 1.5	≤ 1.5		-	260	340
	TN-C		iPF65 2P		≤ 1.5	≤ 1.5	-		340	340	-
	TN-C		iPF65 3P	8	≤ 1.5	-	-	230/400	340	-	-
	TT & TN-S	■	iPF65r 3P+N		-	≤ 1.5	≤ 1.5		-	260	340
	TT & TN-S		iPF65 3P+N		-	≤ 1.5	≤ 1.5		-	260	340
	TN-C	■	iPF65r 4P		≤ 1.5	≤ 1.5	-		340	340	-
iPF40											
	TT & TN		iPF40 1P	2	≤ 1.5	-	-	230	340	-	-
	TT & TN-S		iPF40 1P+N	4	-	≤ 1.5	≤ 1.5		-	260	340
	TN-C		iPF40 2P		≤ 1.5	≤ 1.5	-		340	340	-
	TN-C		iPF40 3P	8	≤ 1.5	-	-	230/400	340	-	-
	TT & TN-S	■	iPF40r 3P+N		-	≤ 1.5	≤ 1.5		-	260	340
	TT & TN-S		iPF40 3P+N		-	≤ 1.5	≤ 1.5		-	260	340
	TN-C	■	iPF40r 4P		≤ 1.5	≤ 1.5	-		340	340	-
	TN-C		iPF40 4P		≤ 1.5	≤ 1.5	-		340	340	-
iPF20											
	TT & TN		iPF20 1P	2	≤ 1.1	-	-	230	340	-	-
	TT & TN-S		iPF20 1P+N	4	-	≤ 1.5	≤ 1.1		-	260	340
	TN-C		iPF20 2P		≤ 1.1	≤ 1.1	-		340	340	-
	TN-C		iPF20 3P	8	≤ 1.1	-	-	230/400	340	-	-
	TT & TN-S		iPF20 3P+N		-	≤ 1.5	≤ 1.1		-	260	340
	TN-C		iPF20 4P		≤ 1.1	≤ 1.1	-		340	340	-
iPF8 (1) Type 2 / Type 3											
	TT & TN		iPF8 1P	2	≤ 1 / ≤ 1.1	-	-	230	340	-	-
	TT & TN-S		iPF8 1P+N	4	-	≤ 1.5 / ≤ 1.2	≤ 1 / ≤ 1.1		-	260	340
	TN-C		iPF8 2P		≤ 1 / ≤ 1.1	≤ 1 / ≤ 1.1	-		340	340	-
	TN-C		iPF8 3P	8	≤ 1 / ≤ 1.1	-	-	230/400	340	-	-
	TT & TN-S		iPF8 3P+N		-	≤ 1.5 / ≤ 1.2	≤ 1 / ≤ 1.1		-	260	340
	TN-C		iPF8 4P		≤ 1 / ≤ 1.1	≤ 1 / ≤ 1.1	-		340	340	-

* **CM**: common mode (phase to earth and neutral to earth). * **DM**: differential mode (phase to neutral). (1) **Uoc**: combined waveform voltage: 10 kV.

Protection
Load protection

iPF surge arresters

Type 2 or 3 LV surge arresters (cont.)

Connection

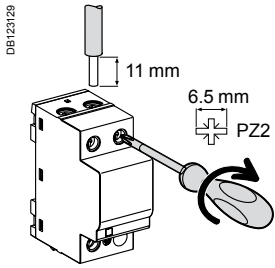

Type	Tightening torque	Copper cables	
		Rigid	Flexible or with ferrule
iPF	3.5 N.m	25 mm ² max.	16 mm ² max.

Technical data

Main characteristics		
Operating frequency	50/60 Hz	
Operating voltage (Ue)	230/400 V AC	
Permanent operating current (Ic)	< 1 mA	
Response time	< 25 ns	
End of life indication: by green/red indicator light	Green	In operation
	Red	At end of life
End of life remote indication	By contact NO, NC 250 V / 0.25 A	
Additional characteristics		
Operating temperature	-25°C to +60°C	
Type of connection terminals	Tunnel terminals, 2.5 to 35 mm ²	
Standards	IEC 61643-1 <u>T2</u> and EN 61643-11 Type 2	

Weight (g)

Surge arrester	
Type	iPF
1P	125
2P	210
3P	335
4P	420

Dimensions (mm)

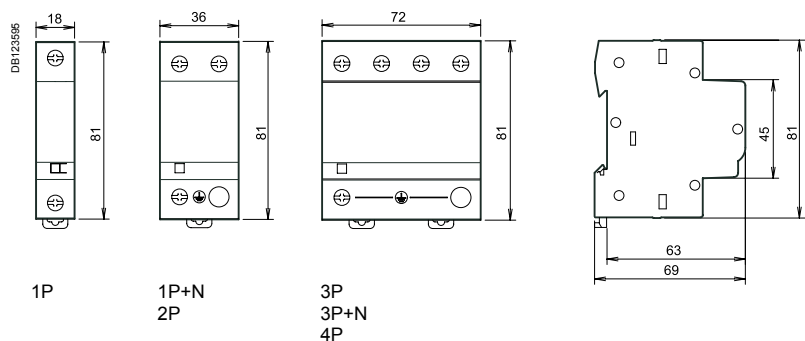

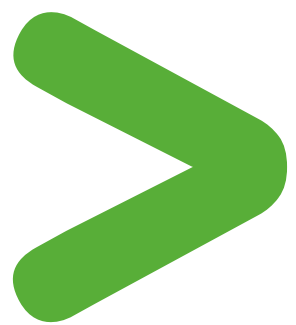

Protection

Load protection

iPRD surge arresters

Type 2 or 3 LV withdrawable surge arresters



iPRD withdrawable surge arresters allow quick replacement of damaged cartridges.
 Type 2 surge arresters are tested with a 8/20 µs current wave.
 Type 3 surge arresters are tested with a 1.2/50 µs and 8/20 µs combined wave.

Each surge arrester in the range has a specific application:

- **incoming protection (type 2):**
 - the iPRD65r is recommended for a very high risk level (strongly exposed site)
 - the iPRD40(r) is recommended for a high risk level
 - the iPRD20(r) is recommended for a medium risk level
- **secondary protection (type 2 or 3):**
 - the iPRD8(r) ensures secondary protection of loads to be protected and is placed in cascade with the incoming surge arresters. This surge arrester is required when the loads to be protected are at a distance of more than 10 m from the incoming surge arrester.

The iPRD surge arresters with “r” indication have remote transfer of the information: “cartridge to be replaced”.

Catalogue number iPRD surge arresters



2P



4P

Rated discharge current (Imax)	Nominal discharge current (In)	Type of protection		Network								
		Incoming	Secondary	1P+N	3P+N	1P	2P	3P	4P			
iPRD65												
65 kA Very high risk level (strongly exposed site)	20 kA	iPRD65				A9L65101						
						A9L65121						
				A9L65501			A9L65201					
								A9L65301				
								A9L65321				
						A9L65601						A9L65401
iPRD40												
40 kA High risk level	15 kA	iPRD40				A9L40101						
						A9L40100						
				A9L40501								
				A9L40500			A9L40201					
							A9L40200					
								A9L40301				
								A9L40321				
								A9L40300				
						A9L40601						A9L40401
						A9L40600						A9L40421
								A9L40400				
iPRD20												
20 kA Medium risk level	5 kA	iPRD20				A9L20100						
				A9L20501								
				A9L20500								
							A9L20200					
								A9L20300				
								A9L20321				
						A9L20601						A9L20400
						A9L20600						A9L20421
iPRD8												
8 kA Secondary protection: placed near the loads to be protected when they are at a distance of more than 10 m from the incoming surge arrester	2.5 kA	iPRD8				A9L08100						
				A9L08501								
				A9L08500								
							A9L08200					
								A9L08300				
								A9L08321				
						A9L08601						A9L08400
						A9L08600						A9L08421

Protection

Load protection

iPRD surge arresters

Type 2 or 3 LV withdrawable surge arresters (cont.)



Cartridge

Spare cartridges iPRD

Type	Spare cartridges for	Cat. no
iPRD 65-350	iPRD65r	A9L65102
iPRD 40-350	iPRD40, iPRD40r	A9L40102
iPRD 20-350	iPRD20, iPRD20r	A9L20102
iPRD 8-350	iPRD8, iPRD8r	A9L08102
iPRD Neutral	All products (1P+N, 3P+N)	A9L00002

Spare cartridges iPRD IT

Type	Spare cartridges for	Cat. no
C 65-460	iPRD65r IT	A9L65122
C 40-460	iPRD40r IT	A9L40122
C 20-460	iPRD20r IT	A9L20122
C 8-460	iPRD8r IT	A9L08122

	Earthing system	Transfer	Surge arrester name	Width in mod. of 9 mm	Up - (kV) Voltage protection level			Un - (V) Rated voltage network	Uc - (V) Maximum continuous operating voltage		
					CM*		DM*		CM*		DM*
					L/±	N/±			L/N	L/±	
iPRD65											
A9L65101	TT & TN	■	iPRD65r 1P	2	≤ 1.5	-	-	230	350	-	-
A9L65121	IT	■	iPRD65r 1P IT		≤ 2.3	-	-		460	-	-
A9L65501	TT & TN-S	■	iPRD65r 1P+N	4	-	≤ 1.4	≤ 1.5		-	260	350
A9L65201	TN-C-S	■	iPRD65r 2P		≤ 1.5	≤ 1.5	-		350	350	-
A9L65301	TN-C	■	iPRD65r 3P	6	≤ 1.5	-	-	230/400	350	-	-
A9L65321	IT	■	iPRD65r 3P IT		≤ 2.3	-	-		460	-	-
A9L65601	TT & TN-S	■	iPRD65r 3P+N	8	-	≤ 1.4	≤ 1.5		-	260	350
A9L65401	TN-C-S	■	iPRD65r 4P		≤ 1.5	≤ 1.5	-		350	350	-
iPRD40											
A9L40101	TT & TN	■	iPRD40r 1P	2	≤ 1.6	-	-	230	350	-	-
A9L40100	TT & TN		iPRD40 1P		≤ 1.6	-	-		350	-	-
A9L40501	TT & TN-S	■	iPRD40r 1P+N	4	-	≤ 1.4	≤ 1.6		-	260	350
A9L40500	TT & TN-S		iPRD40 1P+N		-	≤ 1.4	≤ 1.6		-	260	350
A9L40201	TN-C-S	■	iPRD40r 2P		≤ 1.6	≤ 1.6	-		350	350	-
A9L40200	TN-C-S		iPRD40 2P		≤ 1.6	≤ 1.6	-		350	350	-
A9L40301	TN-C	■	iPRD40r 3P	6	≤ 1.6	-	-	230/400	350	-	-
A9L40321	IT	■	iPRD40r 3P IT		≤ 2.2	-	-		460	-	-
A9L40300	TN-C		iPRD40 3P		≤ 1.6	-	-		350	-	-
A9L40601	TT & TN-S	■	iPRD40r 3P+N	8	-	≤ 1.4	≤ 1.6		-	260	350
A9L40600	TT & TN-S		iPRD40 3P+N		-	≤ 1.4	≤ 1.6		-	260	350
A9L40401	TN-C-S	■	iPRD40r 4P		≤ 1.6	≤ 1.6	-		350	350	-
A9L40421	IT	■	iPRD40r 4P IT		≤ 2.2	≤ 2.2	-		460	-	-
A9L40400	TN-C-S		iPRD40 4P		≤ 1.6	≤ 1.6	-		350	350	-
iPRD20											
A9L20100	TT & TN		iPRD20 1P	2	≤ 1.2	-	-	230	350	-	-
A9L20501	TT & TN-S	■	iPRD20r 1P+N	4	-	≤ 1.4	≤ 1.2		-	260	350
A9L20500	TT & TN-S		iPRD20 1P+N		-	≤ 1.4	≤ 1.2		-	260	350
A9L20200	TN-C-S		iPRD20 2P		≤ 1.2	≤ 1.2	-		350	350	-
A9L20300	TN-C		iPRD20 3P	6	≤ 1.2	-	-	230/400	350	-	-
A9L20321	IT	■	iPRD20r 3P IT		≤ 1.8	-	-		460	-	-
A9L20601	TT & TN-S	■	iPRD20r 3P+N	8	-	≤ 1.4	≤ 1.2		-	260	350
A9L20600	TT & TN-S		iPRD20 3P+N		-	≤ 1.4	≤ 1.2		-	260	350
A9L20400	TN-C-S		iPRD20 4P		≤ 1.2	≤ 1.2	-		350	350	-
A9L20421	IT	■	iPRD20r 4P IT		≤ 1.8	≤ 1.8	-		460	-	-
iPRD8 (1)											
Type 2 / Type 3 (1)											
A9L08100	TT & TN		iPRD8 1P	2	≤ 1.2	-	-	230	350	-	-
A9L08501	TT & TN-S	■	iPRD8r 1P+N	4	-	≤ 1.4	≤ 1.2		-	260	350
A9L08500	TT & TN-S		iPRD8 1P+N		-	≤ 1.4	≤ 1.2		-	260	350
A9L08200	TN-C-S		iPRD8 2P		≤ 1.2	≤ 1.2	-		350	350	-
A9L08300	TN-C		iPRD8 3P	6	≤ 1.2	-	-	230/400	350	-	-
A9L08321	IT	■	iPRD8r 3P IT		≤ 1.6 / ≤ 1.8	-	-		460	-	-
A9L08601	TT & TN-S	■	iPRD8r 3P+N	8	-	≤ 1.4	≤ 1.2		-	260	350
A9L08600	TT & TN-S		iPRD8 3P+N		-	≤ 1.4	≤ 1.2		-	260	350
A9L08400	TN-C-S		iPRD8 4P		≤ 1.2	≤ 1.2	-		350	350	-
A9L08421	IT	■	iPRD8r 4P IT		≤ 1.6 / ≤ 1.8	≤ 1.6 / ≤ 1.8	-		460	-	-

* **CM**: common mode (phase to earth and neutral to earth). * **DM**: differential mode (phase to neutral). (1) **Uoc**: combined waveform voltage: 10 kV.

Protection
Load protection

iPRD surge arresters

Type 2 or 3 LV withdrawable surge arresters

Connection iPRD surge arresters

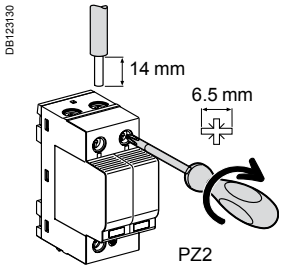

Type	Tightening torque	Copper cables	
		Rigid	Flexible or with ferrule
iPRD	3.5 N.m	2.5 to 25 mm ²	4 to 16 mm ²

Technical data iPRD surge arresters

Main characteristics	iPRD	iPRD IT
Operating frequency	50/60 Hz	
Operating voltage (U _e)	230/400 V AC ±10 %	
Permanent operating current (I _c)	< 1 mA	
Response time	< 25 ns	
Short circuit current rating (I _{sc})	50 kA (50 Hz)	-
Short circuit current rating (I _{sc}), case of double fault	-	5 kA (50 Hz)
Temporary overvoltage withstand (U _T)	U _T (L-N) 442 V AC / 120 min	337 V AC / 5 s 337 V AC / 5 s
Temporary overvoltage	U _T (N-PE) 1200 V AC / 200 ms	- 1455 V AC / 200 ms
Safe failure mode (U _T)	U _T (L-PE) 1455 V AC / 200 ms	- 1455 V AC / 200 ms
Ground residual current (I _{PE})	I _{PE} (L-PE) 600 µA for 1P, 2P, 3P, 4P	-
	I _{PE} (N-PE) 3 µA for 1P+N, 3P+N	-
Satisfactory operation indication:	White	In operation
by mechanical indicator	Red	Cartridge must be replaced
Remote indication of satisfactory operation		By contact NO, NC 250 V / 0.25 A

Additional characteristics		
Degree of protection (IEC 60529)	Device only Device in modular enclosure	IP20 (built-in) IP40
Operating temperature	-25°C to +60°C	
Storage temperature	-40°C to +85°C	
Humidity range	5 % to 95 %	
Type of connection terminals	Tunnel terminals, 2.5 to 35 mm ²	
Standards	IEC 61643-11: 2011 <u>T2</u> , <u>T3</u> and EN 61643-11: 2012 Type 2, Type 3	

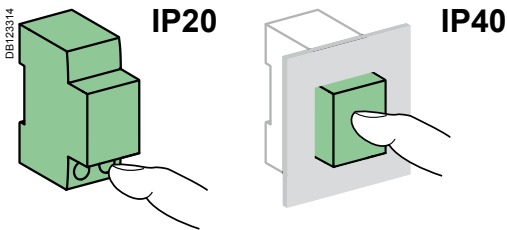

Surge arrester/circuit breaker association

Surge arrester	Associated circuit breaker		
	iPRD		iPRD IT
	I _{sc} ≤ 25 kA	I _{sc} ≤ 50 kA	I _{sc} (IT 400 V AC) ≤ 5 kA
iPRD65	Curve C 50 A	Curve C 63 A	Curve C 25 A
iPRD40	Curve C 40 A	Curve C 63 A	Curve C 20 A
iPRD20	Curve C 20 A	Curve C 63 A	Curve C 10 A
iPRD8	Curve C 10 A	Curve C 63 A	Curve C 10 A

iPRD dimensions (mm)

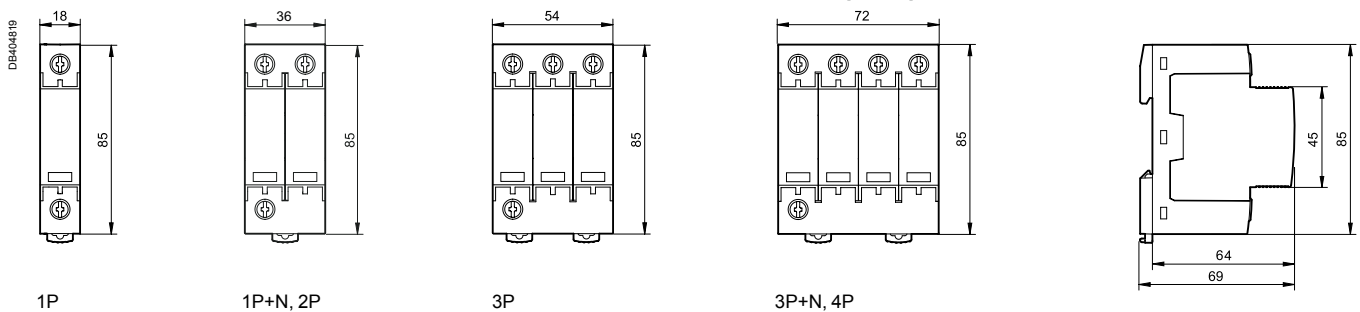

Weight (g)

Surge arrester	
Type	iPRD
1P	119
1P+N, 2P	220
3P	340
3P+N, 4P	450

Protection

Load protection

iPRD surge arresters

Type 2 or 3 LV withdrawable surge arresters (cont.)

iPRD surge arresters

PB110281-80

Satisfactory operation indication
 ■ By mechanical indicator
 □ white: operating
 □ red: cartridge must be replaced



Connection iPRD surge arrester with its short circuit disconnecter

TT / TN-S

Power supply through the top
 Connection with cables

PB110289-50



Surge arrester iPRD 3P+N + iC60N 3P+N

Reversible
 ■ The surge arrester base can be turned over to allow the phase/neutral/earth cables to enter through either the top or the bottom

TT / TN-S

Power supply through the bottom
 Connection with comb busbar

PB110783-50



Surge arrester iPRD 3P+N + iC60N 3P+N

IT/TNC-S with neutral

Power supply through the top
 Connection with comb busbar

PB110287-50



Surge arrester iPRD 4P + iC60N 4P

IT/TNC-S with neutral

Power supply through the bottom
 Connection with comb busbar

PB110784-50



Surge arrester iPRD 4P + iC60N 4P

Protection Load protection iPRC, iPRI surge arresters

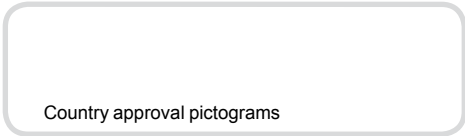

Protection against overvoltages related to lightning strikes.



Analogue telephone line protection: the iPRC surge arrester wired in series to the private installation input protects the telephones, the PABX, the modems (including ADSL), etc.

Protection for 2 low-current lines without common potential or 4 lines with common reference potential: the iPRI protects the measuring instrument and PLC "sensor" inputs and the DC power supply inputs up to 53 V and AC power supply inputs up to 37 V. The input current must not exceed 300 mA.

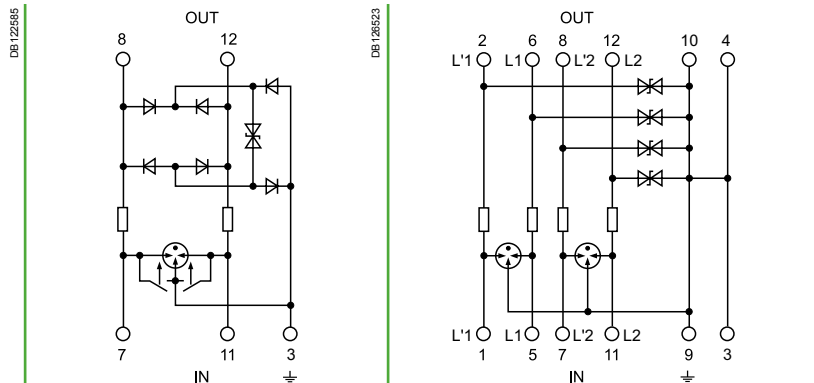

Line L1	Cables 7-8	Line L1	Cables 5-6
Line L2	Cables 11-12	Line L2	Cables 11-12
-	-	Line L'1	Cables 1-2
-	-	Line L'2	Cables 7-8
⊕	Cable 3	⊕	Cables 3-4-9-10
IN	Ligne side	IN	Ligne side
OUT	Protected side	OUT	Protected side

Catalogue numbers

Surge arresters	iPRC	iPRI
Mains voltage (Un)	<130 V AC	48 V DC
Analogue telephone system	■	-
Telephone transmitter	■	-
Digital telephone system	-	■
Automation network	-	■
VLV load power supply (12...48 V)	-	■
xDSL compatibility	■	-
Cat. no..	A9L16337	A9L16339
Width in 9 mm modules	2	2

Diagrams

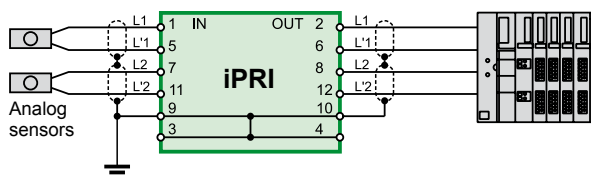
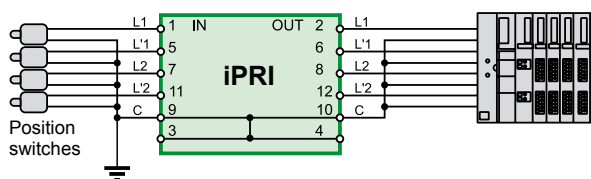
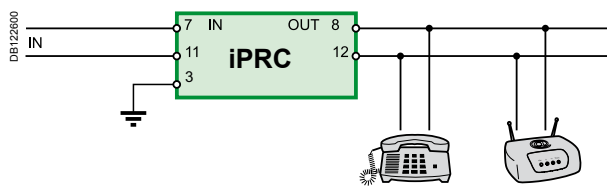

iPRC, iPRI surge arresters (cont.)

Connection

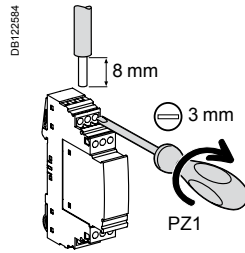

Tightening torque	Copper cables	
	Rigid	Flexible or with ferrule
0.8 N.m	0.2 to 4 mm ²	0.2 to 2,5 mm ²

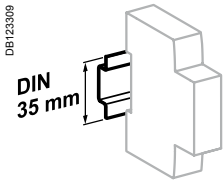

Clip on DIN rail 35 mm.

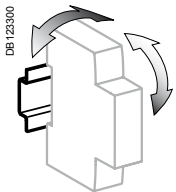

± 30° vertical.

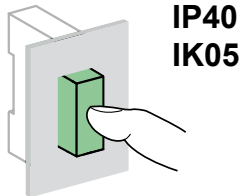
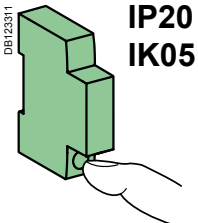

Technical data

Main characteristics			
		iPRC	iPRI
Number of protected lines		2	2
Test category	IEC/EN	C1, C2, C3, D1, B2	C1, C2, C3, D1, B2
Maximum continuous voltage (Uc)		180 V DC, 130 V AC	53 V DC, 37 V AC
Limitation voltage (Up)		300 V	70 V
Rated discharge current (8/20) (In)		10 kA	10 kA
Maximum discharge current (8/20) (Imax)		18 kA	10 kA
Response time		< 500 ns	≤ 1 ns
Nominal impulse current		100 A	70 A
Rated current (I _N)		450 mA (up to 45°C)	300 mA (up to 45°C)
Series resistor		2.2 Ω	4.7 Ω
End-of-life information by		Loss of dialling tone	Loss of transmission
Additional characteristics			
Degree of protection	Device only	IP20	IP20
	Device in modular enclosure	IP40	IP40
	IK	05	05
Operating temperature		-25°C to +60°C	-25°C to +60°C
Storage temperature		-40°C to +85°C	-40°C to +85°C

Weight (g)

Surge arresters		
Type	iPRC	iPRI
	25	65

Dimensions (mm)

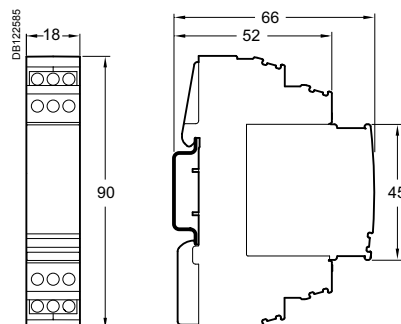

Protection

Load protection

Acti9 iPRE surge arrester

Surge arrester for Ethernet RJ45 sockets



Country approval pictograms

Fine surge protection of Ethernet line Cat. 6



iPRE

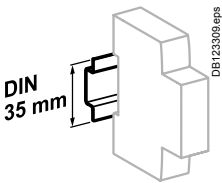

Clip on DIN rail 35 mm.

Weight (g)

Surge arresters	
Type	Acti9 iPRE
	105

Dimensions (mm)

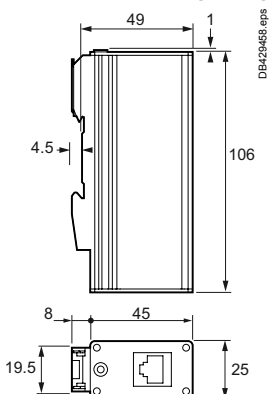

IEC/EN 61643-21

As per the above standard:

iPRE Ethernet line protection

The Acti9 iPRE RJ45 surge arrester protects the Internet line for residential, buildings and industry applications.

Telecommunication equipment are very exposed to lightning overvoltages as they often have long cables which behave like antennas to such surge lightnings and electrostatic discharges created by switching transients in buildings. The interfaces operate with low signal levels at high frequencies. This makes them particularly sensitive to surge voltages and can lead to the destruction of IT systems.

Short response times are essential to quickly limit the surge voltages without deteriorating signal quality. Wired in series to the private installation input, it allows better data exchange between computers and peripheral devices.

- Acti9 iPRE is suitable for category 5 & 6 Ethernet cabling system, high speed data networks up to 250 MHz.
- Acti9 iPRE is delivered with an earthing cable which provides protective grounding in computer rooms.
- Acti9 iPRE is DIN rail mounted.
- RJ45 system-specific connection.

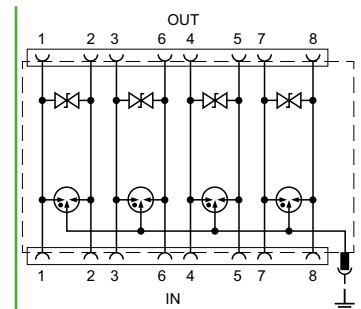

IN	Line side
OUT	Protected side

Catalog number

Surge arresters	Acti9 iPRE
Catalog number	A9L16441

Technical data

Main characteristics	
	Acti9 iPRE
Connections (input - output)	RJ45/RJ45
Test category	IEC/EN C1, C2, D1
Maximum continuous operating voltage (Uc)	6.5 V DC
Voltage protection level at In Line-Line (Up)	35 V
Voltage protection level at In Line-Ground	500 V
Rated discharge current (8/20 μs) (In)	2.5 kA
Maximum discharge current (8/20 μs) (Imax)	10 kA
Nominal impulse current (10/350 μs) (Iimp)	1 kA
Rated load current (I _L)	300 mA (up to 45°C)
Response time	1 ns
Insertion attenuation at 250 MHz	3 db
End-of-life information by	Loss of transmission
Additional characteristics	
Degree of protection (IEC 60529)	IP20
Operating temperature	-40°C to +70°C
Storage temperature	-40°C to +70°C

Protection / Load protection

iPRD PV-DC surge arresters

Withdrawable surge arresters type 2 for photovoltaic applications

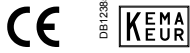

Country approval pictograms

UTE C 61740-51 T2
EN 50539-11: 2013 T2



iPRD 40r 800PV

iPRD PV-DC direct current surge arresters are designed to protect against overvoltages due to a lightning strike: of the "DC" input to the inverter and of photovoltaic panels.

It should be installed in a switchboard inside the building. If the switchboard is located outside, it must be weatherproof.

Withdrawable iPRD PV-DC surge arresters allow damaged cartridges to be replaced quickly.

The surge arrester base can be turned over to allow the phase/neutral/earth cables to enter through either the top or the bottom

They offer remote reporting of the "cartridge must be changed" message.

Catalogue numbers

Internal diagram	I_{Total} (kA) Total discharge current	I_n (kA) Nominal discharge current	U_p (kV) Protection level L+/-, L-/-, L+/L-	U_{CPV} (V) ⁽¹⁾ Maximum continuous operating voltage L+/-, L-/-, L+/L-	Width in module of 9 mm	Cat. no.
<p>iPRD 40r 800PV</p>	40	15	3	800	6	A9L40271
<p>iPRD 40r 1000PV</p>	40	15	3.9	1000	6	A9L40281

(1) $U_{cpv} \geq 1.2 \times U_{oc\ stc}$ ($U_{oc\ stc}$: maximum no-load voltage of the photovoltaic generator "photovoltaic module manufacturer's data")



Replacement cartridges

Replacement cartridges

Type	Replacement cartridges for	Cat. no.
C 40-800PV	iPRD 40r 800PV	A9L40172
C 40-1000PV	iPRD 40r 1000PV	A9L40182

iPRD PV-DC surge arresters

Withdrawable surge arresters type 2 for photovoltaic applications (cont.)

Connection

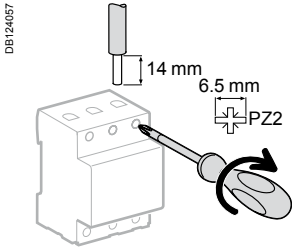

Type	Tightening torque	Copper cables	
		Rigid	Flexible or with ferrule
iPRD PV-DC	3.5 N.m	2.5 to 25 mm ²	2.5 to 16 mm ²

Depending on the distance between the "generator" part and the "conversion" part, it may be necessary to install two surge arresters or more, to ensure protection of each of the two parts.

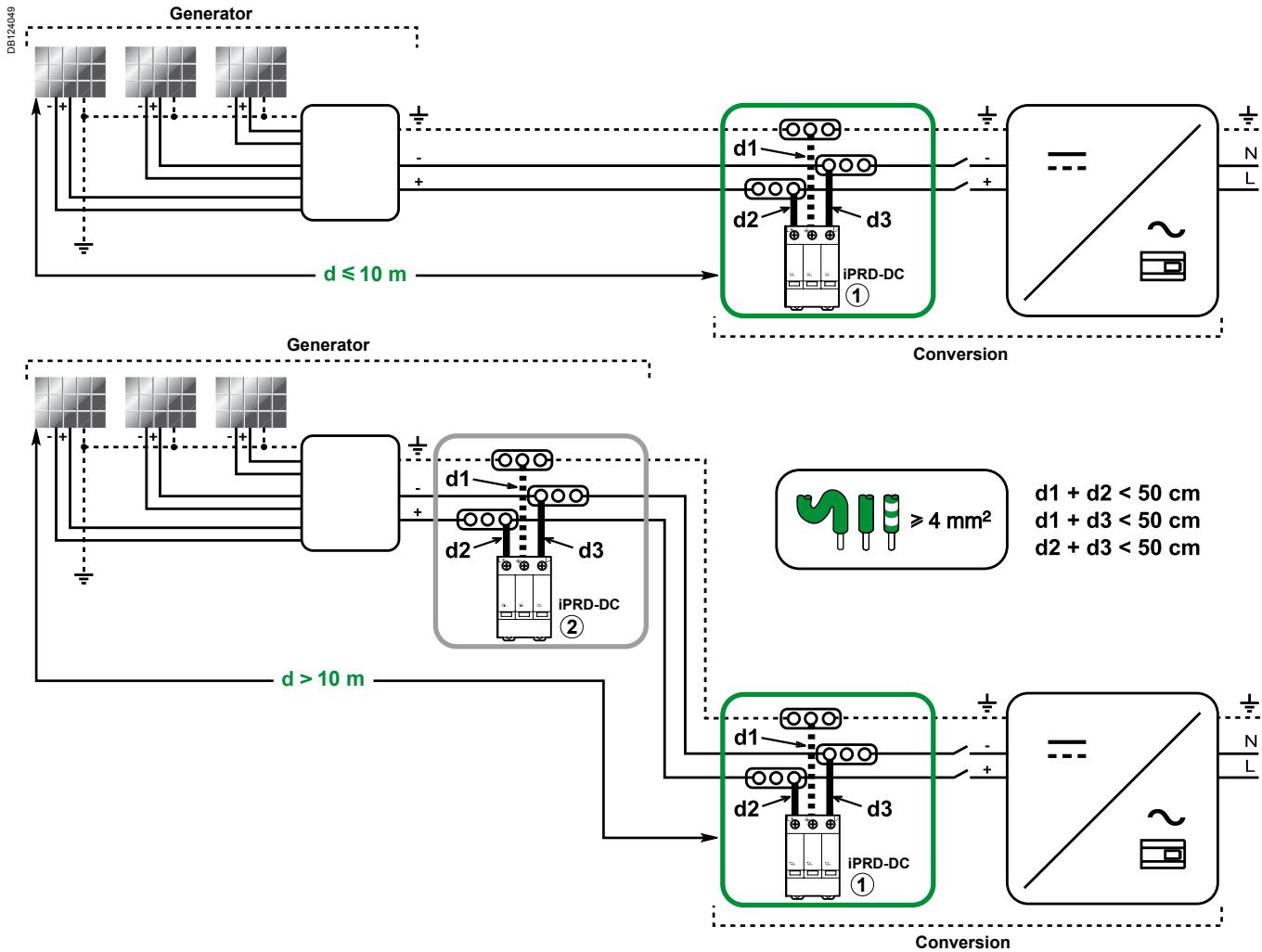

iPRD PV-DC surge arresters

Withdrawable surge arresters type 2 for photovoltaic applications

Application diagram

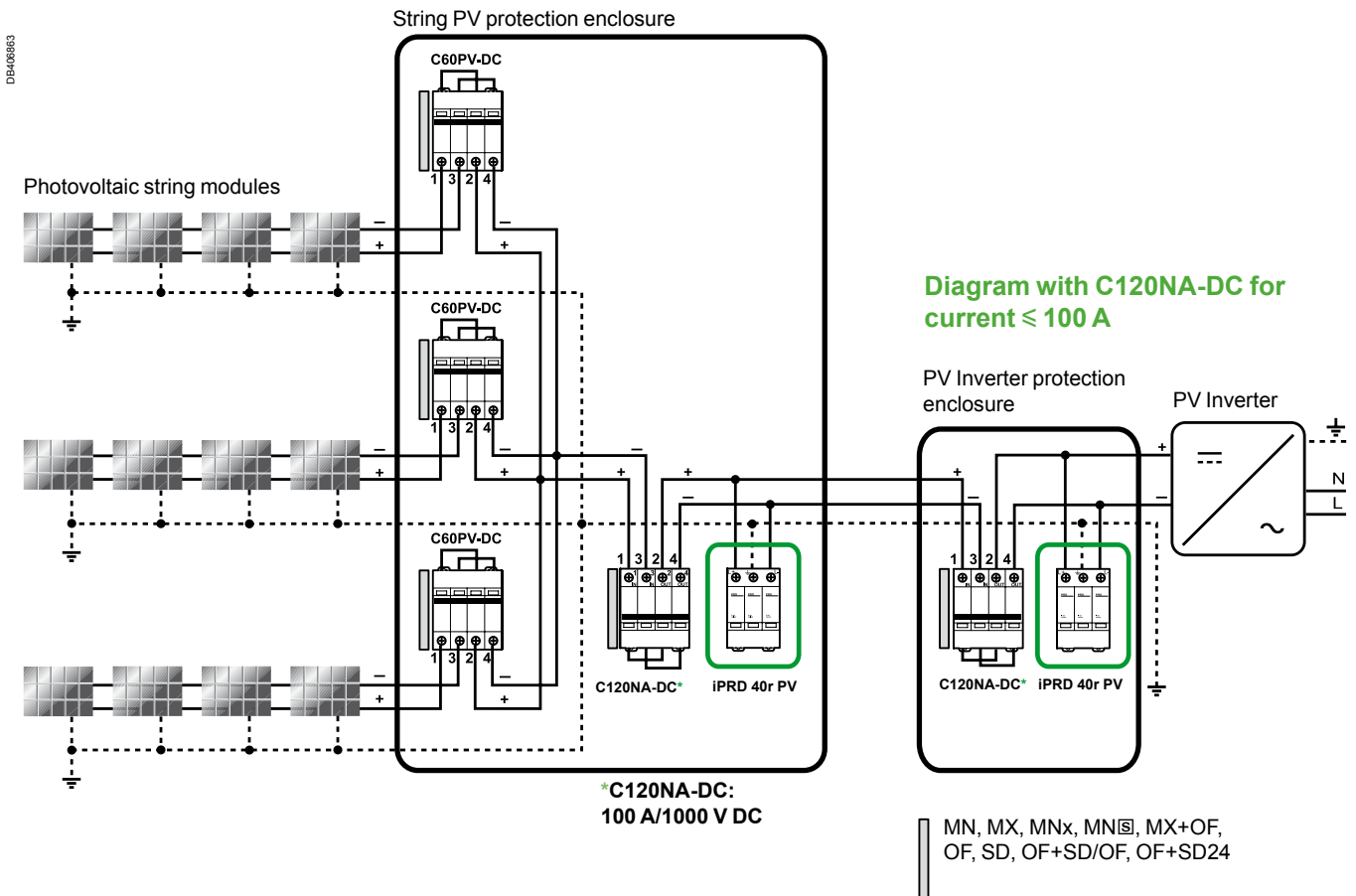

DE400863

Protection / Load protection

iPRD PV-DC surge arresters

Withdrawable surge arresters type 2 for photovoltaic applications

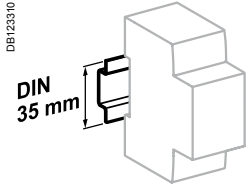

Clip on DIN rail 35 mm.

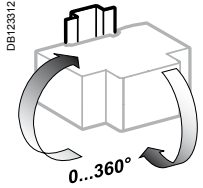

Indifferent position of installation.

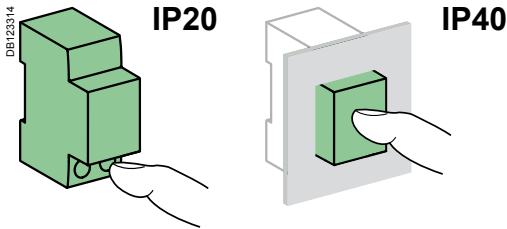

Technical data

Main characteristics			
Type of network	Isolated direct current		
Maximum continuous operating voltage (U_{CPV})	iPRD 40r 800PV	800 V	
	iPRD 40r 1000PV	1000 V	
Response time	< 25 ns		
Permanent operating current (I_c)	< 1 mA		
Short circuit current (I_{SCPV})	200 A		
Type of surge arresters	Type 2		
Ground residual current	I_{PE} (AC)	600 μ A	
	I_{PE} (DC)	60 μ A	
End-of-life indication mode	Circuit opened by integrated thermal disconnecter		
Additional characteristics			
Degree of protection (IEC 60529)	Device only	IP20	
	Device in modular enclosure	IP40	
	Chocs	IK03	
Satisfactory operation indication	By the cartridges	White	Operational
		Red	Cartridge must be replaced
		By the NO/NC remote indication contact 250 V AC / 0.25 A	
Operating temperature	-25°C to +60°C		
Storage temperature	-40°C to +85°C		
Humidity range	5 % to 95 %		
Standards	UTE C 61740-51 T2 EN 50539-11: 2013 T2		

Weight (g)

Surge arresters	
Type	Weight (g)
iPRD 40r 800PV	400
iPRD 40r 1000PV	400

Dimensions (mm)

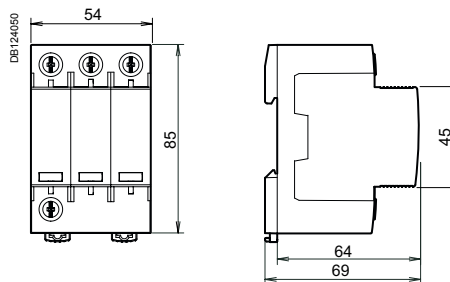

Control Local control iSW switches



IEC/EN 60947-3 As per the above standard:

The switch-disconnectors combine the following functions:

- Control (opening and closing of circuits under load).

iOF auxiliary

- Mounted on the left, it indicates the "open" or "closed" position of the switch and has a normally open (NO) or normally closed (NC) contact.



Catalog numbers

40 to 125 A iSW switch-disconnectors				
Type				Width in 9 mm modules
1P				
	Rating	Voltage (Ue)		2
	40 A	240 V AC	A9S65140	
	63 A	240 V AC	A9S65163	
	100 A	240 V AC	A9S65191	
125 A	240 V AC	A9S65192		
2P				
	Rating	Voltage (Ue)		4
	40 A	415 V AC	A9S65240	
	63 A	415 V AC	A9S65263	
	100 A	415 V AC	A9S65291	
125 A	415 V AC	A9S65292		
3P				
	Rating	Voltage (Ue)		6
	40 A	415 V AC	A9S65340	
	63 A	415 V AC	A9S65363	
	100 A	415 V AC	A9S65391	
125 A	415 V AC	A9S65392		
4P				
	Rating	Voltage (Ue)		8
	40 A	415 V AC	A9S65440	
	63 A	415 V AC	A9S65463	
	100 A	415 V AC	A9S65491	
125 A	415 V AC	A9S65492		
Operating frequency		50/60 Hz		
Accessories		Catalog modules CA907000 and CA907001		



Auxiliary			
Type			Width in 9 mm modules
iOF			1
	Voltage (Ue)		
	240...415 V AC	A9A26924	
	24...130 V DC		

Control

Local control

iSW switches (cont.)



Dimensions (mm)

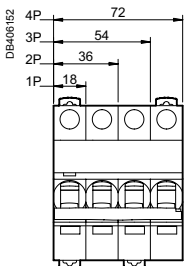

iSW

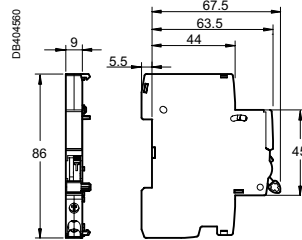
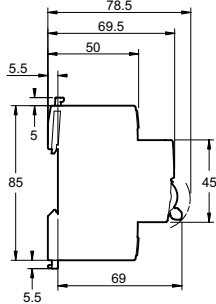

iOF

Control Local control iSW switches (cont.)

Connection

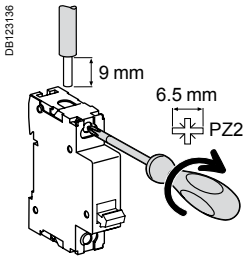

Type	Rating	Tightening torque	Copper cables	
			Rigid	Flexible or with ferrule
iSW	40 to 125 A	3.5 N.m	 $\leq 50 \text{ mm}^2$	 $\leq 35 \text{ mm}^2$

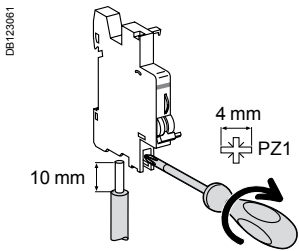

Type	Tightening torque	Copper cables		Multi-cables terminal	
		Rigid	Flexible	Rigid cables	Cables with ferrule
iOF	1 N.m	 1 to 4 mm ²	 0.5 to 2.5 mm ²	 2 x 2.5 mm ²	 2 x 1.5 mm ²

Technical data

Main characteristics			
Insulation voltage (Ui)	500 V AC		
Pollution degree	3		
Power circuit			
Rated impulse withstand voltage (Uimp)	6 kV		
Operating category	AC - 22 A		
Permissible rated short-time withstand current (Icw)	1500 A		
Conditional rated short-circuit current (Inc)	10 kA according to IEC 60947-3		
Rated short-circuit closing current (Icm)	5 kA		
Direct current use			
	iSW 40/63 A		
Operating category	DC-22A		
Voltage rating (Ue)	48 V DC		
	110 V DC with 2 poles in series		
Additional characteristics			
Degree of protection	Device only	IP20	
	Device in modular enclosure	IP40	
Endurance (O-C)	Mechanical	Insulation class II	
		20,000 cycles	
		40 A - 63 A	15,000 cycles
		80 A - 100 A	10,000 cycles
	125 A	2 500 cycles	
Operating temperature	-25°C to +60°C		
Storage temperature	-40°C to +85°C		
Tropicalization	Treatment 2 (relative humidity 95% at 55°C)		

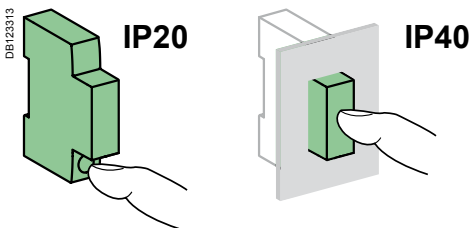

iOF characteristics		
Rated voltage (Ue)	240...415 V AC	
	24...130 V DC	
Operating frequency	50/60 Hz	
Operating current	24 V DC	6 A
	48 V DC	2 A
	60 V DC	1.5 A
	130 V DC	1 A
	240 V AC	6 A
	415 V AC	3 A
Number of contacts	1 NO/NC	
Operating temperature	-35°C to +70°C	
Storage temperature	-40°C to +85°C	

Protection Switch up to 125 A NG125NA switches (cont.)

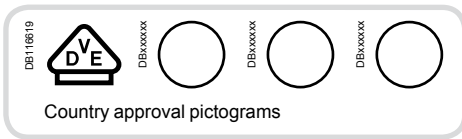

IEC/EN 60947-3

- The NG125NA is a switch-disconnector with free tripping for making and breaking under load.
- It is especially suitable for the modular enclosure incoming feeder with remote breaking (e.g. emergency cutoff).

066908N_SE-2011-35



NG125NA 3P

066909N_SE-2011-35



NG125NA 4P

Catalogue numbers

NG125NA switch		
Type	3P	3P+N
Auxiliaries	Remote indication and tripping, module CM907005	
Rating (In)	Quality label (1)	
63 A	18889	18893
80 A	18890	18894
100 A	18891	18895
125 A	18892	18896
Width in 9 mm modules	9	12
Accessories	Module CM907006	

(1) Information to be supplied by the country concerned.

Protection Switch up to 125 A NG125NA switches (cont.)

Connection

Rating	Tightening torque	Without accessories			With accessories				
		Copper cables			70 mm ² Al terminal	Screw-on connection for ring terminal	Small ring terminal	Multi-cable terminal	
		Rigid	Flexible or with ferrule					Rigid cables	Flexible cables
		DB122945	DB122946	DB123410	DB123488	DB118789	DB118789	DB118787	
63 A	3.5 N.m	1.5 to 50 mm ²	1.5 to 35 mm ²	-	-	-	-	3 x 16 mm ²	3 x 10 mm ²
80 to 125 A	6 N.m	16 to 70 mm ²	10 to 50 mm ²	25 to 70 mm ²	2 x 35 mm ² 1 x 50 mm ²	1 x 70 mm ²			

■ For rating ≥ 80 A: upstream voltage taps for each pole, by 6.35 mm Fast-on terminal.

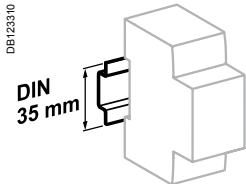

Clips onto 35 mm DIN rail.

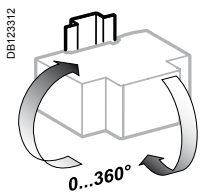

Any installation position.

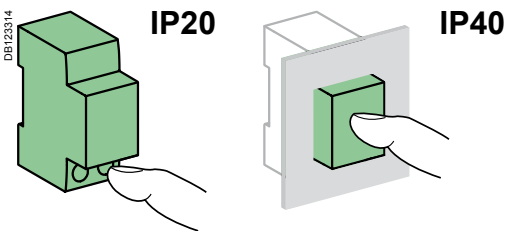

Technical data

Main characteristics			
According to IEC/EN 60947-3			
Max. voltage rating (Ue)	500 V AC		
Insulation voltage (Ui)	690 V AC		
Degree of pollution	3		
Rated impulse withstand voltage (Uimp)	8 kV		
Short time withstand current (50 ms) Icw	1.5 kA		
Rated short-circuit closing current (Icm)	2 kA		
Utilization category	AC22A/B - AC23B		
Additional characteristics			
Degree of protection	Device only	IP20	
	Device in modular enclosure	IP40	
Endurance (O-C)		Category A	Category B
Electrical (except AC20 and DC20)	≤ 100 A	1500 cycles	300 cycles
	125 A	1000 cycles	200 cycles
Mechanical		20,000 cycles	
Operating temperature		-30°C to +70°C	
Storage temperature		-40°C to +70°C	
Tropicalization (IEC 60068-1)		Treatment 2 (relative humidity of 95% at 55°C)	

Protection
 Switch up to 125 A
 NG125NA switches (cont.)

Weight (g)

Switch	
Type	NG125NA
3P	720
4P	960

Dimensions (mm)

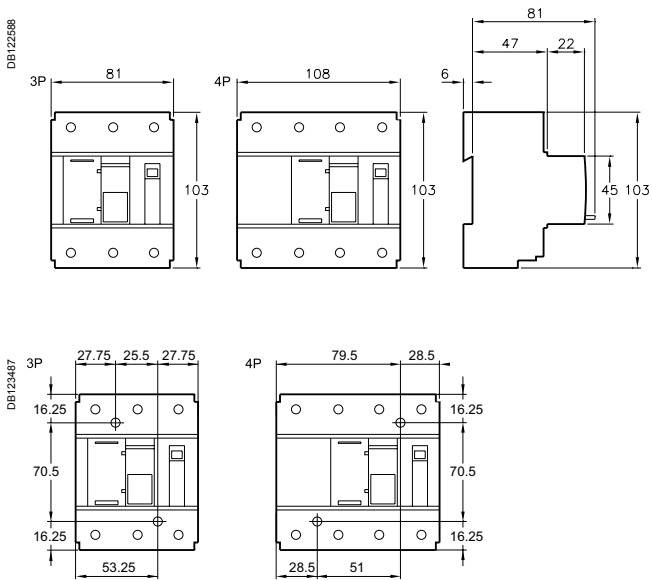

Spacing for mounting on panel

Protection Switch up to 125 A NG125NA switches (cont.)

056909N_SE-2011-90

DB123493



- For rating ≥ 80 A**
- Voltage taps:
 - auxiliaries power supply
 - measurement
 - emergency stop
 - remote reporting



- Cable strength:
 - ribbed cage
 - terminal depth
 - tightening by Allen hex key (NG125 ≥ 80 A)

- Integrated padlocking device

- Test button to check satisfactory operation of the tripping mechanism



- Pull-out strength:
 - metallic lock

- Impact and vibration resistance:
 - high-strength enclosure
 - IK 05

- Central manual control, 3 positions:
 - ON
 - tripped on fault
 - open

- Circuit breaker tripped indicator

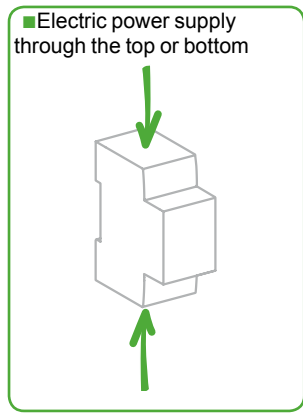

- Positive contact indication:
 - suitability for isolation in the industrial sector to IEC/EN 60947-3;
 - the presence of the green strip guarantees that the contacts open physically and allows work to be carried out safely on the downstream circuit.

- Longer product service life due to:
 - good overvoltage withstand capacity;
 - high limitation performances;
 - fast closure independent of the speed of actuation of the toggle.

Protection

Circuit protection / Earth leakage protection

Accessories and auxiliaries for iC40, iCV40

Connection accessories

See module CA907001

7	Screw-on connection for ring terminal	27053
8	Comb busbar	See module CA907026

Mounting accessories

See module CA907001

9	Padlocking device	A9A26970
19	Padlocking devices (left)	A9A26380
	(right)	A9A26381(1)
10	Clip-on terminal markers	See module CA907001

(1) only for iC40

Security accessories

See module CA907001

11	9 mm spacer	A9A27062
----	-------------	----------

Spare part

See module CA907001

12	Locking clip	A9A27052
----	--------------	----------

Electrical auxiliaries

See module CA907002

Indication		
2	iSD fault indicating contact	A9A26927
3	iOF open/close auxiliary contact	A9A26924
4	iOF/SD+OF auxiliary contact (OF+SD or OF+OF)	See module CA907002
5	iOF+SD24 auxiliary contact	See module CA907002

Tripping devices

1	iMN undervoltage release or iMNs undervoltage release delayed or iMNx undervoltage release with external feeding or shunt release iMX, iMX+OF overvoltage release iMSU	See module CA907002
---	--	---------------------

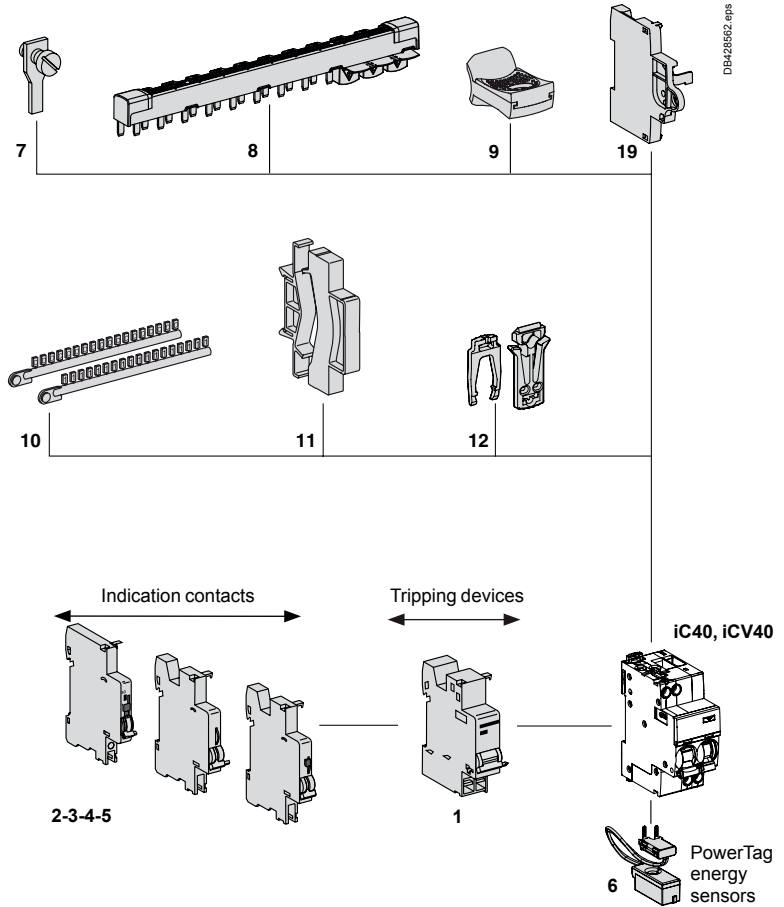

Note Tripping devices must be installed first.
 If two tripping devices: the iMN must be installed first
 Indication auxiliaries: respect specified position for SD functions.

PowerTag energy sensors

6	Energy sensors PowerTag A9 P63	See module CA907029
---	--------------------------------	---------------------

Assembly rule

The mounting order and the number for the various auxiliaries must be complied with.

The tripping auxiliaries (iMN, iMX, iMSU...) must be mounted first **1** as close as possible to the main device.

Then at the left, the indicating auxiliaries (iOF, iSD...) must be mounted **2** then **3**, complying with the following association table.

Indicating auxiliaries		Tripping auxiliaries		Device
3	+ 2	+ 1		
1 (iOF/SD+OF or iOF+SD24 or iSD)	1 iOF/SD+OF	1 (iMN, iMNs, iMNx or iMX, iMX+OF or iMSU)	iC40, iCV40	
1 iOF	1 (iSD or iOF or iOF/SD+OF)	2 (iMN, iMNs, iMNx or iMX, iMX+OF or iMSU)		
-	1 iOF+SD24	2 (iMN, iMNs, iMNx or iMX, iMX+OF or iMSU)		
-	-	3 iMSU		
1 iSD	1 iSD	1 (iMN, iMNs, iMNx or iMX, iMX+OF or iMSU)		

Protection

Circuit protection / Earth leakage protection

Accessories and auxiliaries iID40

Connection accessories

See module CA907001

7	Screw-on connection for ring terminal	27053
8	Comb busbar	See module CA907026
13	Multi-cable terminal	See module CA907001
14	Al terminal	27060

Mounting accessories

See module CA907001

9	Padlocking device	A9A26970
19	Padlocking device (left)	A9A26380
10	Clip-on terminal markers	See module CA907001

Security accessories

See module CA907001

11	9 mm spacer	A9A27062
15	Interpole barrier	See module CA907001
16	Screw shield	See module CA907001
17	Terminal shield	See module CA907001

Spare parts

See module CA907001

12	Locking clip	A9A27052
18	Flap	See module CA907001

Electrical auxiliaries

See module CA907002

Signalisation		
2	iSD fault indicating contact	A9A26927
3	iOF open/close auxiliary contact	A9A26924
4	iOF/SD+OF auxiliary contact (OF+SD or OF+OF)	See module CA907002
5	iOF+SD24 auxiliary contact	See module CA907002

Déclencheurs		
1	iMN undervoltage release or iMNs undervoltage release delayed or iMNx undervoltage release with external feeding or shunt release iMX, iMX+OF overvoltage release iMSU	See module CA907002

PowerTag energy sensors		
6	Energy sensors PowerTag A9 P63	See module CA907029

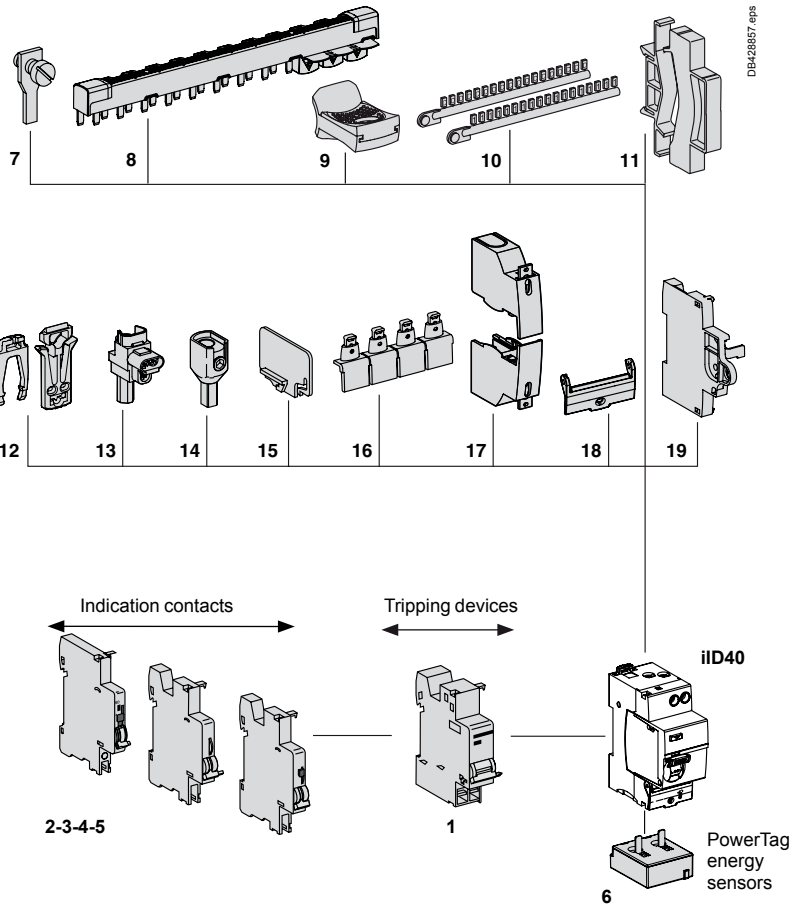

Note Tripping devices must be installed first.
 If two tripping devices: the iMN must be installed first
 Indication auxiliaries: respect specified position for SD functions.

Assembly rule

The mounting order and the number for the various auxiliaries must be complied with. The tripping auxiliaries iMN, iMX, iMSU... must be mounted first **1** as close as possible to the main device. Then at the left, the indicating auxiliaries (iOF, iSD...) must be mounted **2** then **3**, complying with the following association table.

Indicating auxiliaries		Tripping auxiliaries	Device
3	+	+	
1 (iOF/SD+OF or iOF+SD24 or iSD)	2	1 (iMN, iMNs, iMNx or iMX, iMX+OF or iMSU)	iID40
1 iOF	1 (iSD or iOF or iOF/SD+OF)	2 (iMN, iMNs, iMNx or iMX, iMX+OF or iMSU)	
-	1 iOF+SD24	2 (iMN, iMNs, iMNx or iMX, iMX+OF or iMSU)	
-	-	3 iMSU	
1 iSD	1 iSD	1 (iMN, iMNs, iMNx or iMX, iMX+OF or iMSU)	

Protection

Circuit protection / Earth leakage protection

Accessorisation / Auxiliarisation iC60, iLD, Vigi iC60, iSW-NA

Connection accessories

See module CA907001

9	Splitter blocks Linergy FM	See module	LIN022
	Linergy DX	See module	LIN003
10	50 mm ² Al terminal		27060
11	Screw-on connection for ring terminal		27053
12	Multi-cables terminal	4 parts	19091
		3 parts	19096
13	Comb busbar	See modules	CA907026, CA907027

Mounting accessories

See module CA907001

14	Sealable terminal shields for top and bottom connection	1P (set of 2)	A9A26975
		2P (set of 2)	A9A26976
		3P	1P + 2P
		4P	2P + 2P
15	Interpole barrier (set of 10)		A9A27001
16	Screw shields 4P (set of 20)		A9A26981
16"	Screw shields Vigi iC60 (set of 12)		A9A26982
17	Clip-on terminal markers	See module	CA907001
18	9 mm spacer		A9A27062
19	Padlocking device (set of 10)		A9A26970
20	Plug-in base		A9A27003
21	Rotary handle	Black handle	A9A27005
		Red handle	A9A27006
		No handle	A9A27008

Electrical auxiliaries

See module CA907002

Indication		
4	iOF/SD+OF auxiliary contact (OF+SD or OF+OF combination switch)	A9A26929
5	iSD fault indicating contact	A9A26927
6	iOF open/close auxiliary contact	A9A26924
7	iOF+SD24 auxiliary contact	See module CA907002

Control		
8	iMDU voltage matching auxiliary	A9C18195

Tripping devices		
2	iMN undervoltage release or iMNs undervoltage release delayed or iMNx undervoltage release with external feeding	See module CA907002
3	Shunt release iMX, iMX+OF overvoltage release iMSU	See module CA907002

PowerTag energy sensors		
22	Energy sensors PowerTag A9 M63, F63	See module CA907029

Vigi iC60

1	Vigi iC60 add-on residual current device	See module	CA902005
	Double terminals Vigi iC60 add-on residual current device	See module	CA902019

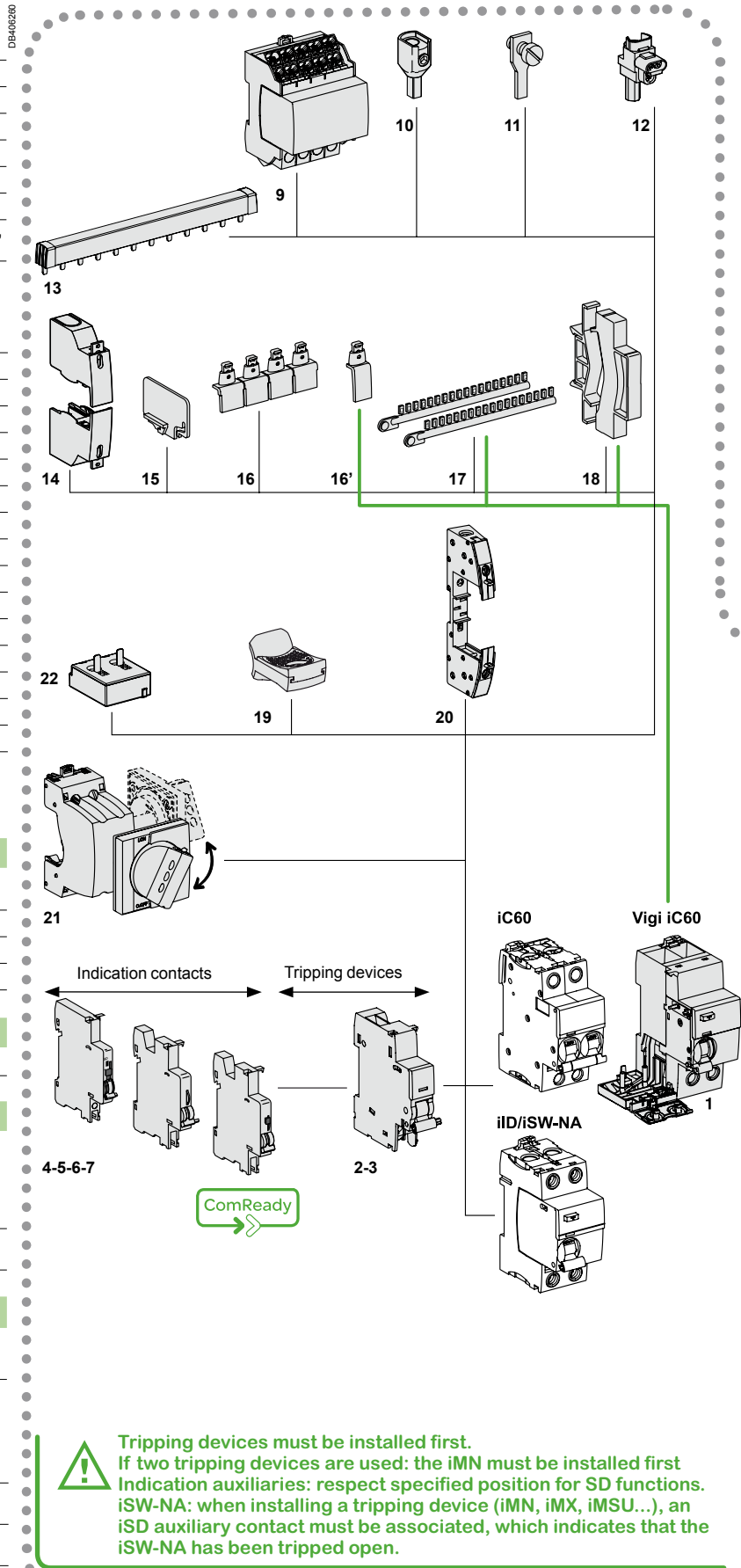

Tripping devices must be installed first.
 If two tripping devices are used: the iMN must be installed first
 Indication auxiliaries: respect specified position for SD functions.
 iSW-NA: when installing a tripping device (iMN, iMX, iMSU...), an iSD auxiliary contact must be associated, which indicates that the iSW-NA has been tripped open.

Protection

Circuit protection / Earth leakage protection

Accessorisation / Auxiliarisation iC60, iID, Vigi iC60, iSW-NA (cont.)

Assembly rule

The mounting order and the number for the various auxiliaries must be complied with.

The tripping auxiliaries (iMN, iMX, iMSU...) should be mounted first **1** as close as possible to the main device.

Then at the left, the indicating auxiliaries (iOF, iSD) should be mounted **2** then **3** complying with the following association table.

Indicating auxiliaries 3	+ 2	Tripping auxiliaries + 1	Remote control	Device	Vigi iC60
1 (iOF/SD+OF or iOF+SD24 or iSD)	1 iOF/SD+OF	1 (iMN, iMNs, iMNx or iMX, iMX+OF or iMSU)	-	iC60, iID, iSW-NA	Vigi iC60
1 iOF	1 (iSD or iOF or iOF/SD+OF)	2 (iMN, iMNs, iMNx or iMX, iMX+OF or iMSU)			
-	1 iOF+SD24	2 (iMN, iMNs, iMNx or iMX, iMX+OF or iMSU)			
-	-	3 iMSU			
1 iSD	1 iSD	1 (iMN, iMNs, iMNx or iMX, iMX+OF or iMSU)	ARA, RCA	iC60	Vigi iC60
-	1 (iSD or iOF or iOF/SD+OF or iOF+SD24)	1 (iMN, iMNs, iMNx or iMX, iMX+OF or iMSU)			
1 iOF	1 (iSD or iOF or iOF/SD+OF)	-			
-	1 (iSD or iOF or iOF/SD+OF or iOF+SD24)	1 (iMN, iMNs, iMNx or iMX, iMX+OF or iMSU) maxi	ARA	iID	-
1 iOF	1 (iSD or iOF or iOF/SD+OF)	-			

DB-04784

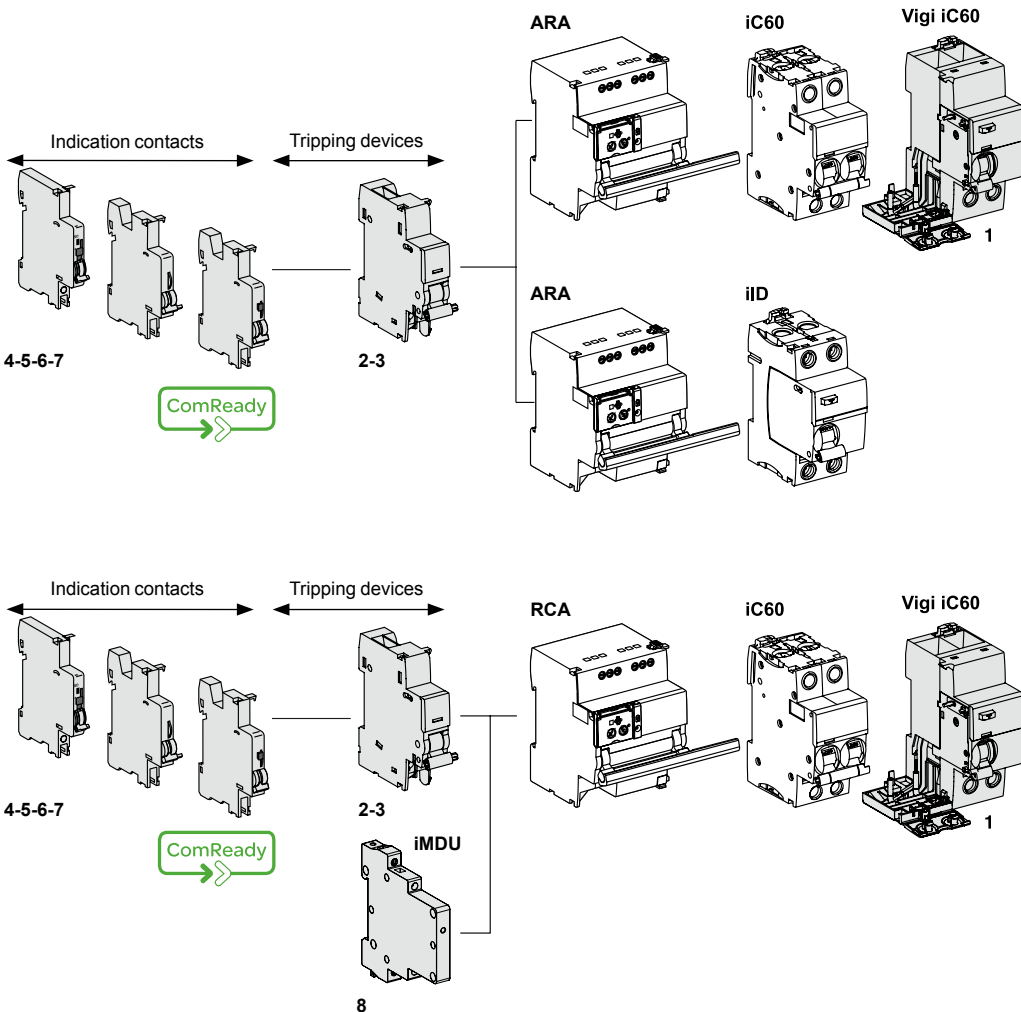

Protection

Circuit protection / Earth leakage protection

Accessorisation / Auxiliarisation Reflex iC60

Connection accessories

See module CA907001

3	Splitter blocks	Linergy FM	See module	LIN022
		Linergy DX	See module	LIN003
4	50 mm ² Al terminal			27060
5	Screw-on connection for ring terminal			27053
6	Multi-cables terminal	4 parts		19091
		3 parts		19096
7	Comb busbar		See modules	CA907026, CA907027

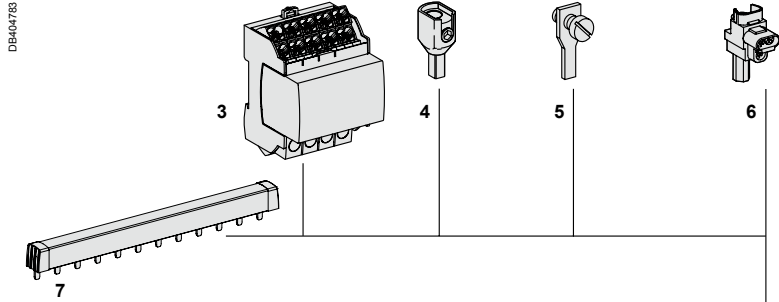

Mounting accessories

See module CA907001

8	Sealable terminal shields for top and bottom connection	1P (set of 2)	A9A26975
		2P (set of 2)	A9A26976
		3P	1P + 2P
		4P	2P + 2P
9	Interpole barrier	(set of 10)	A9A27001
10	Screw shields	4P (set of 20)	A9A26981
11	Clip-on terminal markers		See module CA907001
12	9 mm spacer		A9A27062
13	Padlocking device	(set of 10)	A9A26970

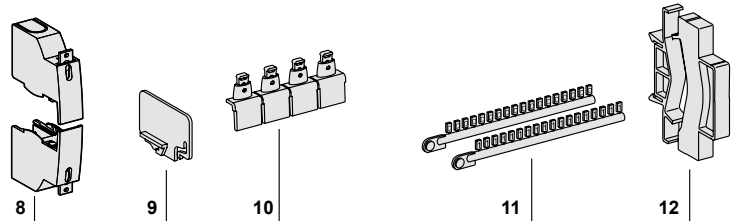

Electrical auxiliary

See module CA907002

Control

2	iMDU voltage matching auxiliary	A9C18195
---	---------------------------------	----------

iMDU

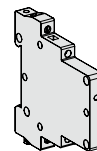

2

Reflex iC60

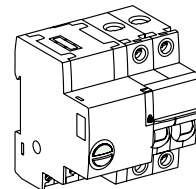

Vigi iC60

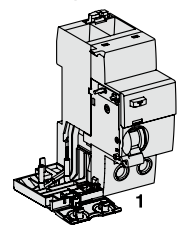

1

Vigi iC60

See module CA907005

1	Vigi iC60 add-on residual current device	See module	CA902005
---	--	------------	----------

Accessorisation / Auxiliarisation iSW

Connection accessories

See module CA907001

2	Splitter blocks	Linergy FM	See module	LIN022
		Linergy DX	See module	LIN003
3	50 mm ² Al terminal			27060
4	Screw-on connection for ring terminal			27053
5	Multi-cables terminal	4 parts		19091
		3 parts		19096
6	Comb busbar		See modules	CA907026, CA907027

DB44785

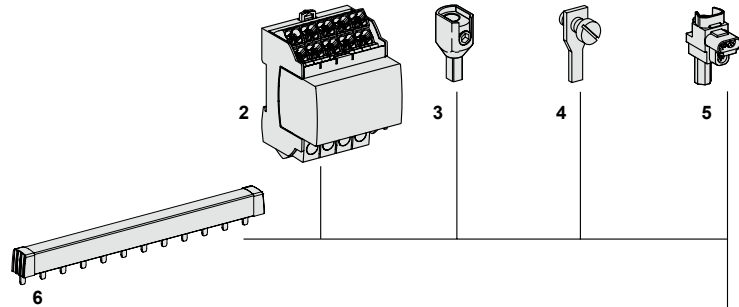

Mounting accessories

See module CA907001

7	Sealable terminal shields for top and bottom connection	1P (set of 2)	A9A26975
		2P (set of 2)	A9A26976
		3P	1P + 2P
		4P	2P + 2P
8	Interpole barrier	(set of 10)	A9A27001
9	Clip-on terminal markers		See module CA907001
10	9 mm spacer		A9A27062
11	Padlocking device	(set of 10)	A9A26970
12	Plug-in base		A9A27003
13	Rotary handle	Black handle	A9A27005
		Red handle	A9A27006
		No handle	A9A27008

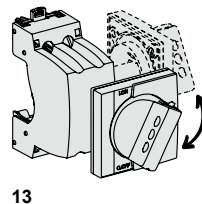
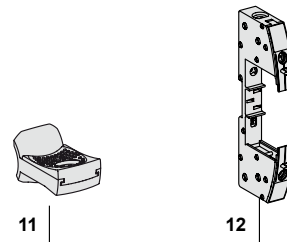
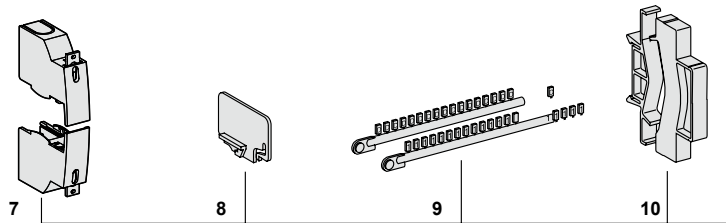

13

Electrical auxiliaries

See module CA907002

Indication

1	iOF open/close auxiliary contact	A9A26924
---	----------------------------------	----------

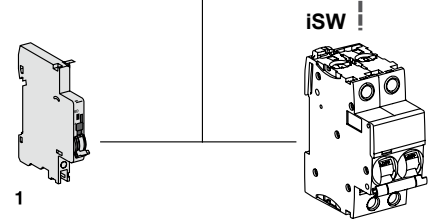

iSW

1

Protection

Circuit protection / Earth leakage protection

Accessories and Auxiliaries for C120, Vigi C120 devices

Connection accessories

See module CA907012

7	Multi-cable terminal	4 parts	19091
		3 parts	19096
8	Screw-on connection for ring terminal	8 parts	27053
9	Terminal for rear connector		18528
10	50 mm ² Al terminal		27060
11	Comb busbar	See module	LIN001

Mounting accessories

See module CA907012

12	Sealable terminal shields for top and bottom connection	1P (set of 2)	18526
13	Interpole barrier	(set of 10)	27001
14	Screw shields	4P (set of 2)	18527
15	Clip-on terminal markers	See module	CA907012
16	9 mm spacer		A9N27062
17	Padlocking device		27145
18	Plug-in base ⁽¹⁾		26997
19	Rotary handle	Removable extended handle	27047
		Fixed handle	27048
		Operating sub-assembly ⁽²⁾	27046

(1) For 1P, centreline between two rows: 200 mm
 (2) A complete rotary handle consists of a circuit-breaker operating sub-assembly, cat. no. 27046, a handle cat. no. 27047 or a handle cat. no. 27048.

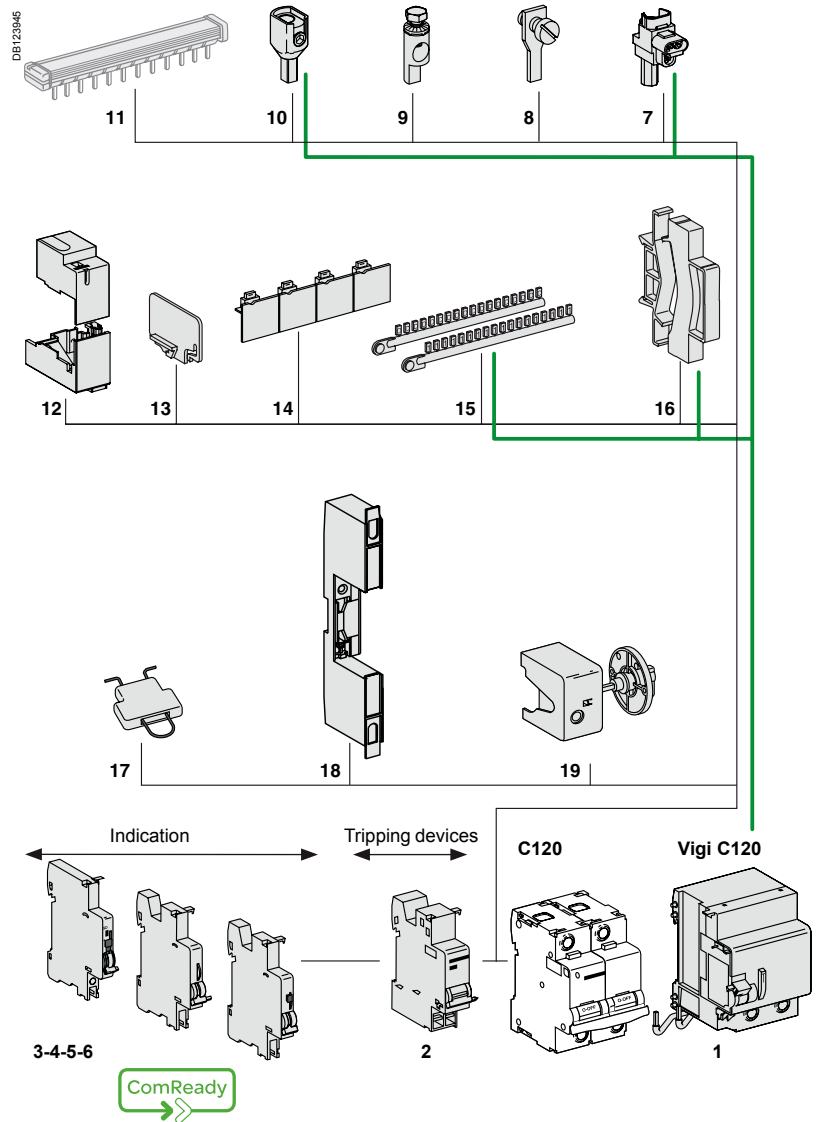

Electrical auxiliaries

See module CA907008

Indication		
3	SD fault indicating contact	A9N26927
4	OF+SD24 auxiliary contact	A9N26899
5	OF open/close auxiliary contact	A9N26924
6	OF+SD/OF auxiliary contact (OF+SD or OF+OF combination switch)	A9N26929

Tripping		
2	MN, MNx, MN \square undervoltage release, MSU overvoltage release or MX, MX + OF shunt release	See module CA907008

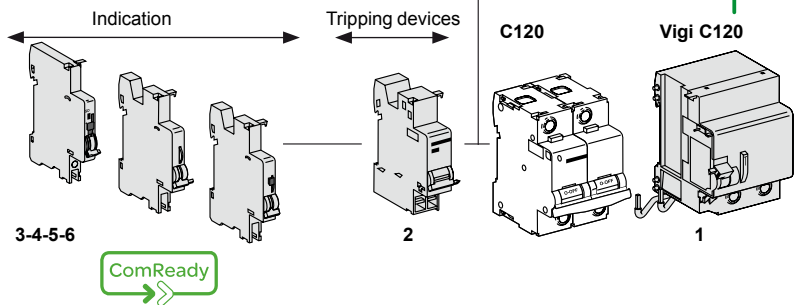

⚠ Tripping devices must be installed first.
If two tripping devices are used: the MN must be installed first
Indication auxiliaries: respect specified position for SD functions.

Vigi C120

See module CA902016

1	Vigi C120 add-on residual current device	See module CA902016
---	--	---------------------

Assembly rule

The mounting order and the number for the various auxiliaries must be complied with. The tripping auxiliaries MN, MX, MSU... should be mounted first **1** as close as possible to the main device. Then at the left, the indicating auxiliaries (OF, SD) should be mounted **2** then **3** complying with the following association table.

Indicating auxiliaries		Tripping auxiliaries		Device	Vigi C120
3	+ 2	+ 1			
1 (OF+SD/OF or OF+SD24)	1 OF+SD/OF	1 (MN, MNx, MN \square or MX, MX+OF or MSU)	C120	Vigi C120	
1 OF	1 (OF+SD/OF or SD or OF)	2 (MN, MNx, MN \square or MX, MX+OF or MSU)			
-	1 OF+SD24	2 (MN, MNx, MN \square or MX, MX+OF or MSU)			
-	-	3 MSU			

Protection

Circuit protection / Earth leakage protection

Accessories and Auxiliaries for C120NA-DC devices

Connection accessories

See module CA907012

6	50 mm ² Al terminal	27060
7	Terminal for rear connector	18528
8	Screw-on connection for ring terminal	8 parts 27053
9	Multi-cable terminal	4 parts 19091
		3 parts 19096

Mounting accessories

See module CA907012

10	Sealable terminal shields for top and bottom connection	1P (set of 2)	18526
11	Interpole barrier	(set of 10)	27001
12	Screw shields	4P (set of 2)	18527
13	Clip-on terminal markers	See module	CA907012
14	9 mm spacer		A9N27062
15	Padlocking device		27145
16	Rotary handle	Removable extended handle	27047
		Fixed handle	27048
		Operating sub-assembly ⁽¹⁾	27046

(1) A complete rotary handle consists of a circuit-breaker operating sub-assembly, cat. no. 27046, a handle cat. no. 27047 or a handle cat. no. 27048.

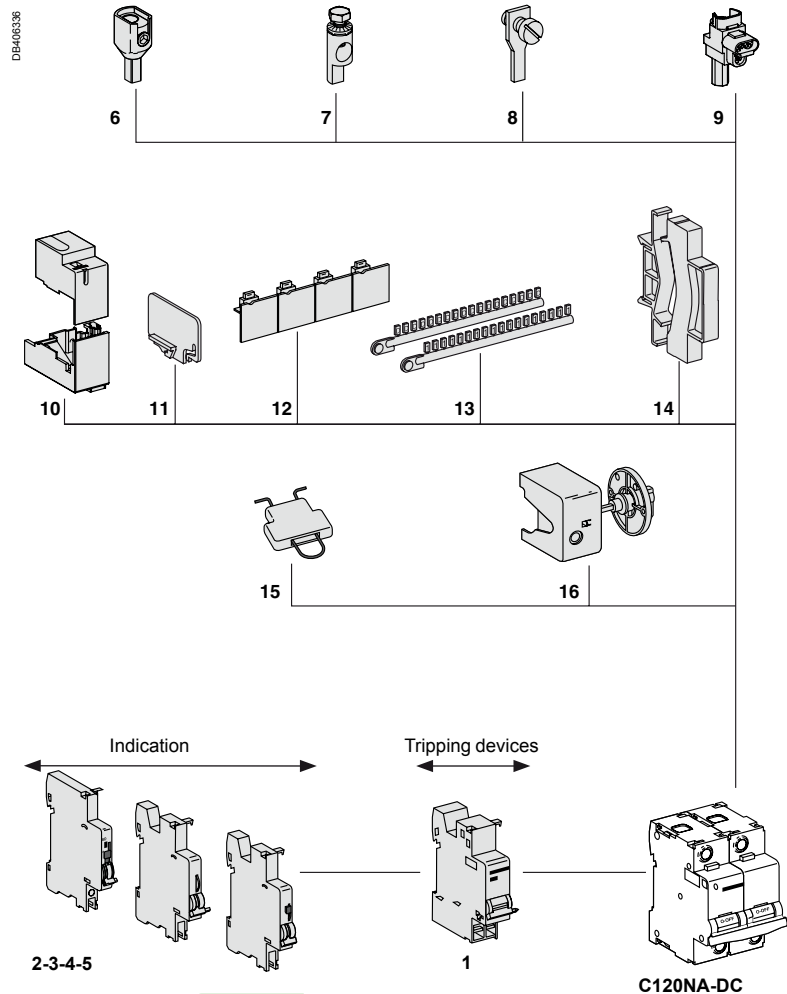

Electrical auxiliaries

See module CA907008

Indication		
2	SD fault indicating contact	A9N26927
3	OF+SD24 auxiliary contact	A9N26899
4	OF open/close auxiliary contact	A9N26924
5	OF+SD/OF auxiliary contact (OF+SD or OF+OF combination switch)	A9N26929

Tripping		
1	MN, MNx, MN [⊗] undervoltage release or MX, MX + OF shunt release	See module CA907008



⚠ Tripping devices must be installed first. If two tripping devices are used: the MN must be installed first
Indication auxiliaries: respect specified position for SD functions.

Assembly rule

The mounting order and the number for the various auxiliaries must be complied with.

The tripping auxiliaries (MN, MX...) should be mounted first **1** as close as possible to the main device.

Then at the left, the indicating auxiliaries (OF, SD) should be mounted **2** then **3** complying with the following association table.

Indicating auxiliaries 3		Indicating auxiliaries + 2		Indicating auxiliaries + 1		Device
1 (OF+SD/OF or OF+SD24)	1 OF+SD/OF	1 (MN, MNx, MN [⊗] or MX, MX+OF)		C120NA-DC		
1 OF	1 (OF+SD/OF or SD or OF)	2 (MN, MNx, MN [⊗] or MX, MX+OF)				
-	1 OF+SD24	2 (MN, MNx, MN [⊗] or MX, MX+OF)				

Protection Circuit protection

Accessories and Auxiliaries for C60 devices

Connection accessories

See module CA907012

6	Insulated connector	See module	LIN001
7	Comb busbar	See module	LIN001
8	50 mm ² Al terminal		27060
9	Ring tongue terminal screw connection		27053
10	Ring tongue terminal connections kit Ø 5 mm, (upstream/downstream)		17400
11	Insulated distribution terminal	4 parts 3 parts	19091 19096

DB406488

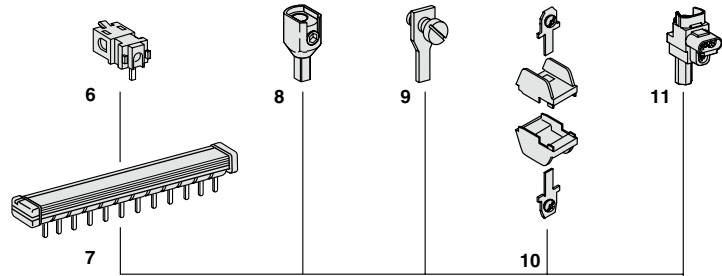

Mounting accessories

See module CA907012

12	Sealable terminal shield	See module	CA907012
13	Inter-pole barrier		27001
14	Rotary handle		
	Switching sub-assembly		27046
	Disconnectable handle		27047
	Fixed handle		27048
15	Screw shield	See module	26981
16	Padlocking accessory (to be locked in the "open" position)		26970
17	Spacer		A9N27062
18	Plug-in base		26996
19	Marker strip	See module	CA907012

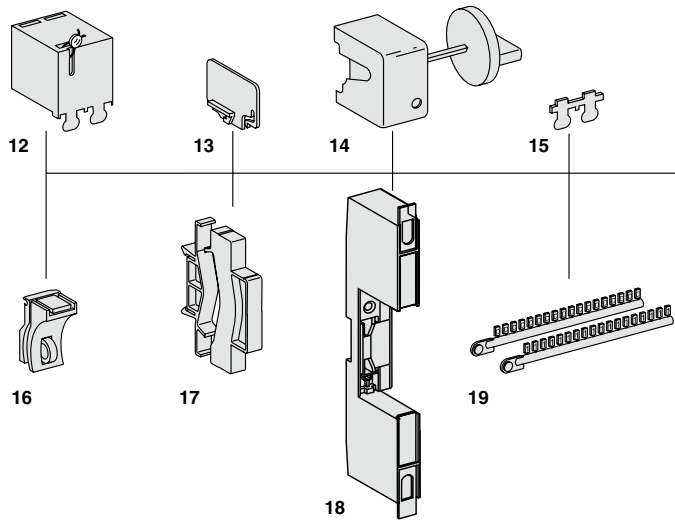

(1) A complete rotary handle consists of a circuit-breaker operating sub-assembly, cat. no. 27046, a handle cat. no. 27047 or a handle cat. no. 27048.

Electrical auxiliaries

See module CA907008

Indication		
2	SD fault indicating contact	A9N26927
3	OF+SD24 auxiliary contact	A9N26899
4	OF open/close auxiliary contact	A9N26924
5	OF+SD/OF auxiliary contact (OF+SD or OF+OF combination switch)	A9N26929

Tripping		
1	MN, MNx, MN [⊗] undervoltage release, MSU overvoltage release or MX, MX + OF shunt release	See module CA907008

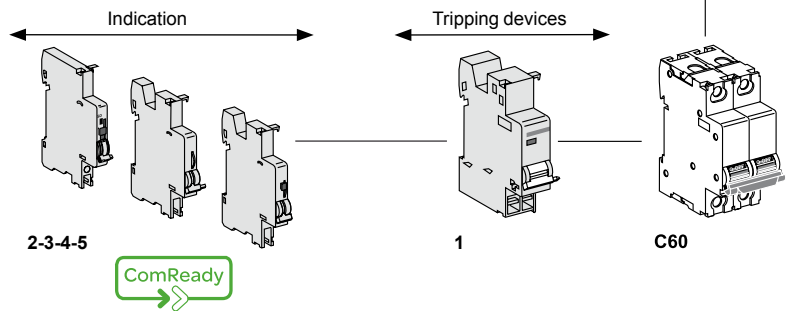

Tripping devices must be installed first.
If two tripping devices are used: the MN must be installed first
Indication auxiliaries: respect specified position for SD functions.

Assembly rule

The mounting order and the number for the various auxiliaries must be complied with.

The tripping auxiliaries (MN, MX...) should be mounted first **1** as close as possible to the main device.

Then at the left, the indicating auxiliaries (OF, SD) should be mounted **2** then **3** complying with the following association table.

Indicating auxiliaries 3		Indicating auxiliaries 2		Indicating auxiliaries 1		Device
1 (OF+SD/OF or OF+SD24)	1 OF+SD/OF	1 (MN, MNx, MN [⊗] or MX, MX+OF or MSU)				
1 OF	1 (OF+SD/OF or SD or OF)	2 (MN, MNx, MN [⊗] or MX, MX+OF or MSU)				
-	1 OF+SD24	2 (MN, MNx, MN [⊗] or MX, MX+OF or MSU)				
-	-	3 MSU				

Protection

Earth leakage protection

Accessories and Auxiliaries for ID devices

Connection accessories

See module CA907012

7	Insulated connector	See module	LIN001
8	Comb busbar	See module	LIN001
9	50 mm ² Al terminal		27060
10	Ring tongue terminal screw connection		27053
11	Ring tongue terminal connections kit Ø 5 mm, (upstream/downstream)		17400
12	Insulated distribution terminal	4 parts	19091
		3 parts	19096

Mounting accessories

See module CA907012

13	Sealable terminal shield	See module	CA907012
14	Inter-pole barrier		27001
15	Screw shield		26981
16	Padlocking accessory (to be locked in the "open" position)		26970
17	Spacer		A9N27062
18	Plug-in base		26996
19	Marker strip	See module	CA907012

Electrical auxiliaries

See module CA907008

Indication		
1	OF.S auxiliary contact	A9N26923
3	SD fault indicating contact	A9N26927
4	OF+SD24 auxiliary contact	A9N26899
5	OF open/close auxiliary contact	A9N26924
6	OF+SD/OF auxiliary contact (OF+SD or OF+OF combination switch)	A9N26929

Tripping		
2	MN, MNx, MN [⊗] undervoltage release, MSU overvoltage release or MX, MX + OF shunt release	See module CA907008

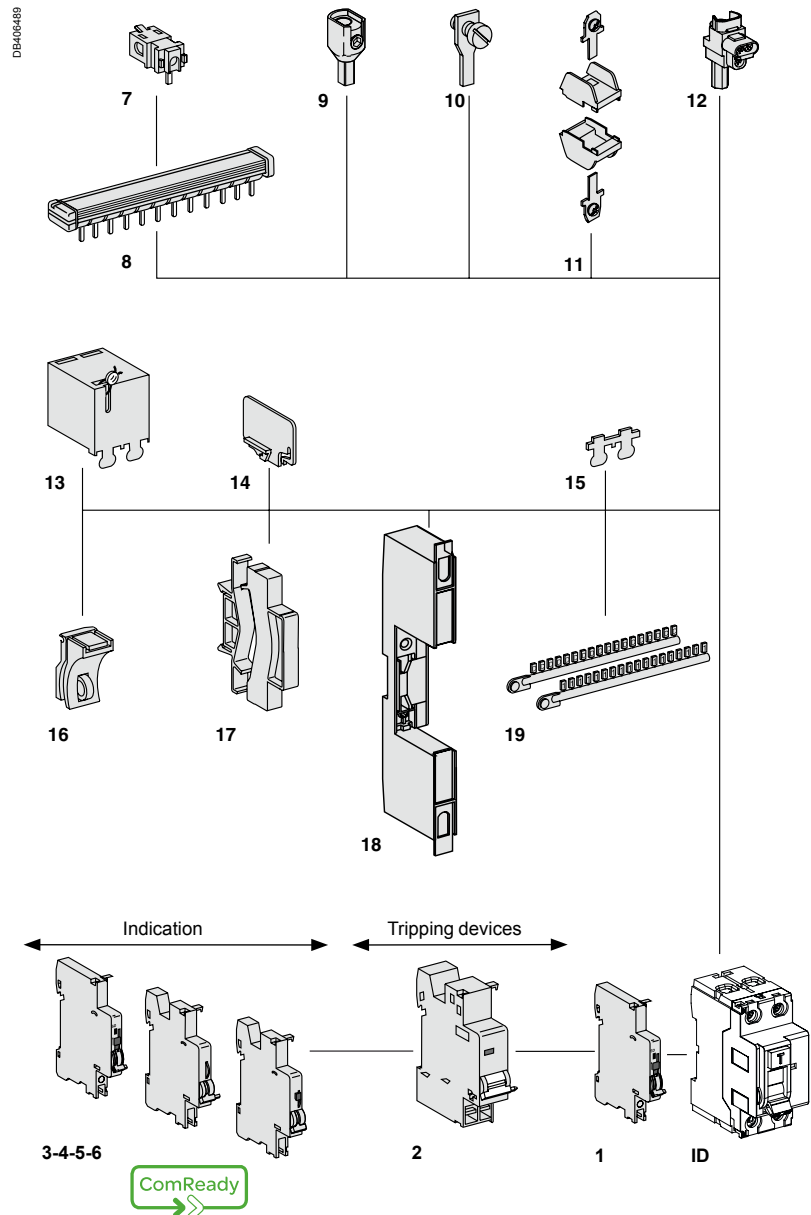

! Tripping devices must be installed first.
If two tripping devices are used: the MN must be installed first
Indication auxiliaries: respect specified position for SD functions.

Assembly rule

The mounting order and the number for the various auxiliaries must be complied with.

The tripping auxiliaries MN, MX...) should be mounted first **1** as close as possible to the main device.

Then at the left, the indicating auxiliaries (OF, SD) should be mounted **2** then **3** complying with the following association table.

Indicating auxiliaries 3		Indicating auxiliaries 2		Indicating auxiliaries 1		Device
-		1 (OF+SD/OF or OF or OF+SD24)		2 (MN, MNx, MN [⊗] or MX, MX+OF or MSU)		
1 OF		1 OF		1 (MN, MNx, MN [⊗] or MX, MX+OF or MSU)		

Protection

Circuit protection / Earth leakage protection

Accessories and Auxiliaries for C60H-DC devices

Connection accessories

See module CA907012

7	Insulated connector	See module LIN001
8	Comb busbar	See module LIN001
9	50 mm ² Al terminal	27060
10	Ring tongue terminal screw connection	27053
11	Ring tongue terminal connections kit Ø 5 mm, (upstream/downstream)	17400
12	Insulated distribution terminal	4 parts 19091 3 parts 19096

DB12415

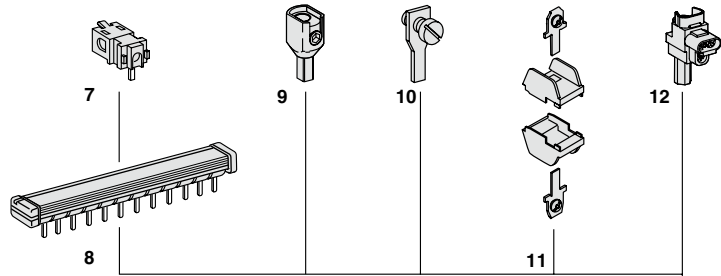

Mounting accessories

See module CA907012

13	Sealable terminal shield	See module CA907012
14	Inter-pole barrier	27001
15	Rotary handle	
	Switching sub-assembly	27046
	Disconnectable handle	27047
	Fixed handle	27048
16	Screw shield	See module CA907012
17	Padlocking accessory (to be locked in the "open" position)	26970
18	Spacer	A9N27062
19	Plug-in base	26996
20	Marker strip	See module CA907012

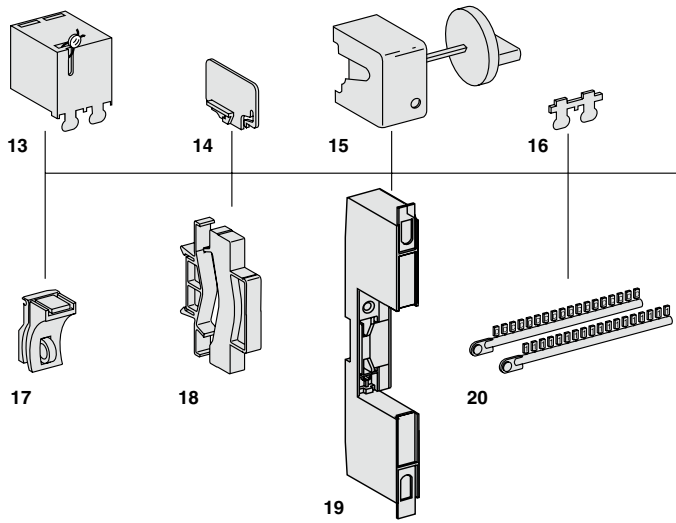

(1) A complete rotary handle consists of a circuit-breaker operating sub-assembly, cat. no. 27046, a handle cat. no. 27047 or a handle cat. no. 27048.

Electrical auxiliaries

See module CA907008

Indication		
3	SD fault indicating switch	A9N26927
4	OF+SD24 auxiliary contact	A9N26899
5	OF open/closed contact	A9N26924
6	OF+SD/OF auxiliary contact (OF+SD or OF+OF combination switch)	A9N26929

Tripping		
1	MN, MNx, MN \square undervoltage release	See module CA907008
2	MX, MX + OF shunt release	See module CA907008

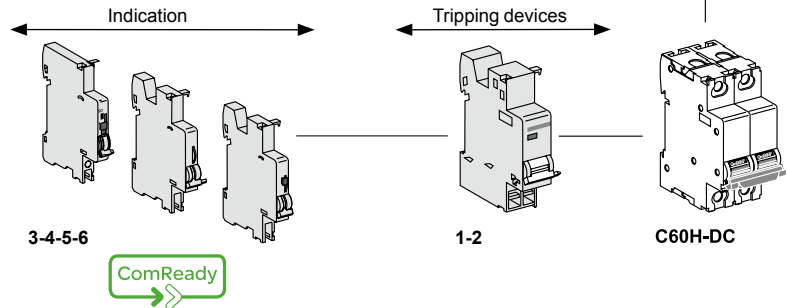

Tripping devices must be installed first.
If two tripping devices are used: the MN must be installed first
Indication auxiliaries: respect specified position for SD functions.

Assembly rule

The mounting order and the number for the various auxiliaries must be complied with.

The tripping auxiliaries MN, MX...) should be mounted first **1** as close as possible to the main device.

Then at the left, the indicating auxiliaries (OF, SD) should be mounted **2** then **3** complying with the following association table.

Indicating auxiliaries 3		Indicating auxiliaries 2		Indicating auxiliaries 1		Device
1 (OF+SD/OF or OF+SD24)		+	1 (OF+SD/OF	1 (MN, MNx, MN \square or MX, MX+OF)		
1 OF			1 (OF+SD/OF or SD or OF)	2 (MN, MNx, MN \square or MX, MX+OF)		
-			1 OF+SD24	2 (MN, MNx, MN \square or MX, MX+OF)		

Accessories and Auxiliaries for iSW devices

Connection accessories

See module CA907012

1	Insulated connector	See module LIN001
2	Comb busbar	See module LIN001
3	50 mm ² Al terminal	27060
4	Ring tongue terminal screw connection	27053
5	Ring tongue terminal connections kit Ø 5 mm, (upstream/downstream)	17400
6	Insulated distribution terminal	4 parts 19091 3 parts 19096

iSW 40...125 A

DB124188

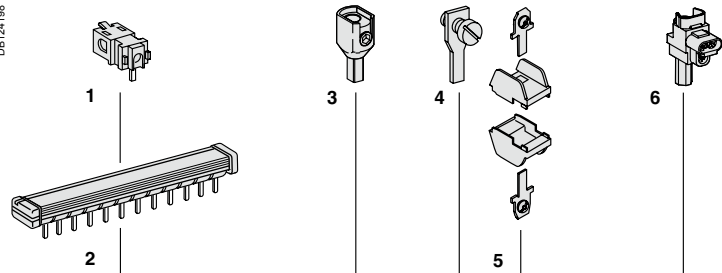

Mounting accessories

See module CA907012

7	Sealable terminal shield	See module CA907012
8	Inter-pole barrier	27001
9	Rotary handle	
	Switching sub-assembly	27046
	Disconnectable handle	27047
	Fixed handle	27048
10	Screw shield	See module CA907012
11	Padlocking accessory (to be locked in the "open" position)	26970
12	Spacer	A9N27062
13	Plug-in base	26996

(1) A complete rotary handle consists of a circuit-breaker operating sub-assembly, cat. no. 27046, a handle cat. no. 27047 or a handle cat. no. 27048.

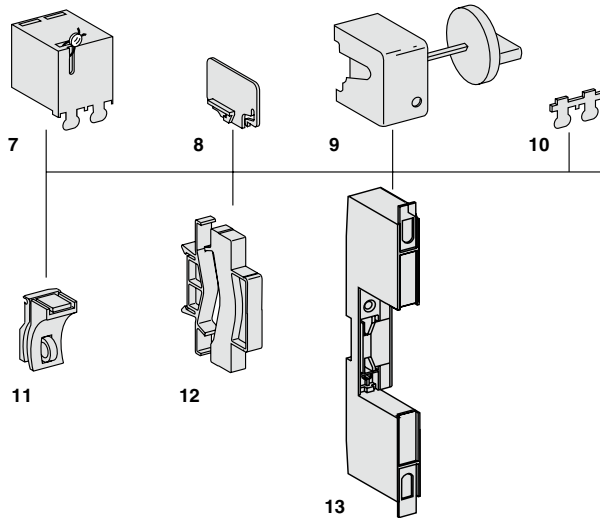

Electrical auxiliary

See module iSW CA904005

Indication	
14	OF iSW open/closed contact A9A15096

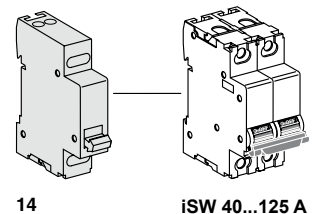

iSW 20...32 A

DB40267

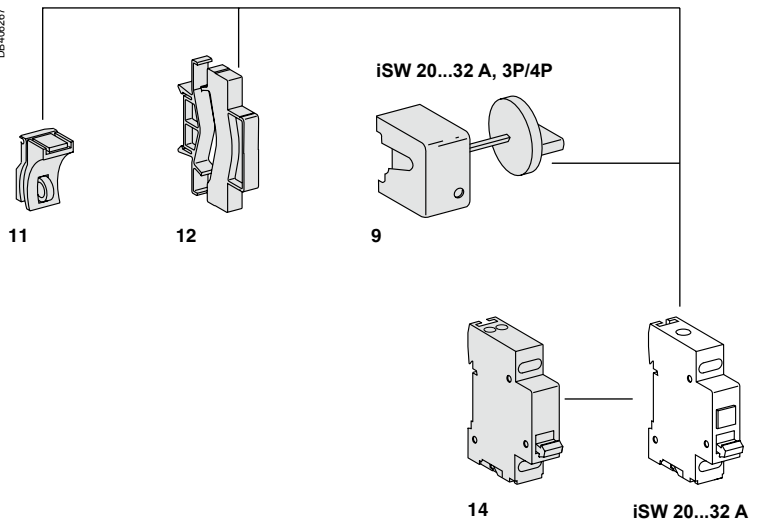

Protection Circuit protection

Accessories and Auxiliaries for SW60-DC, C60NA-DC, C60PV-DC devices

Connection accessories

See module CA907012

7	50 mm ² Al terminal	27060
8	Ring tongue terminal screw connection	27053
9	Insulated distribution terminal	19091
	3 parts	19096

Mounting accessories

See module CA907012

10	Inter-pole barrier	27001
11	Screw shield	26981
12	Padlocking accessory (to be locked in the "open" position)	26970
13	Spacer	A9N27062
14	Marker strip	See module CA907012

Electrical auxiliaries

See module CA907008

Indication		
3	SD fault indicating switch	A9N26927
4	OF+SD24 auxiliary contact	A9N26899
5	OF open/closed contact	A9N26924
6	OF+SD/OF auxiliary contact (OF+SD or OF+OF combination switch)	A9N26929

Tripping		
1	MN, MNx, MN \square undervoltage release	See module CA907008
2	MX, MX + OF shunt release	See module CA907008

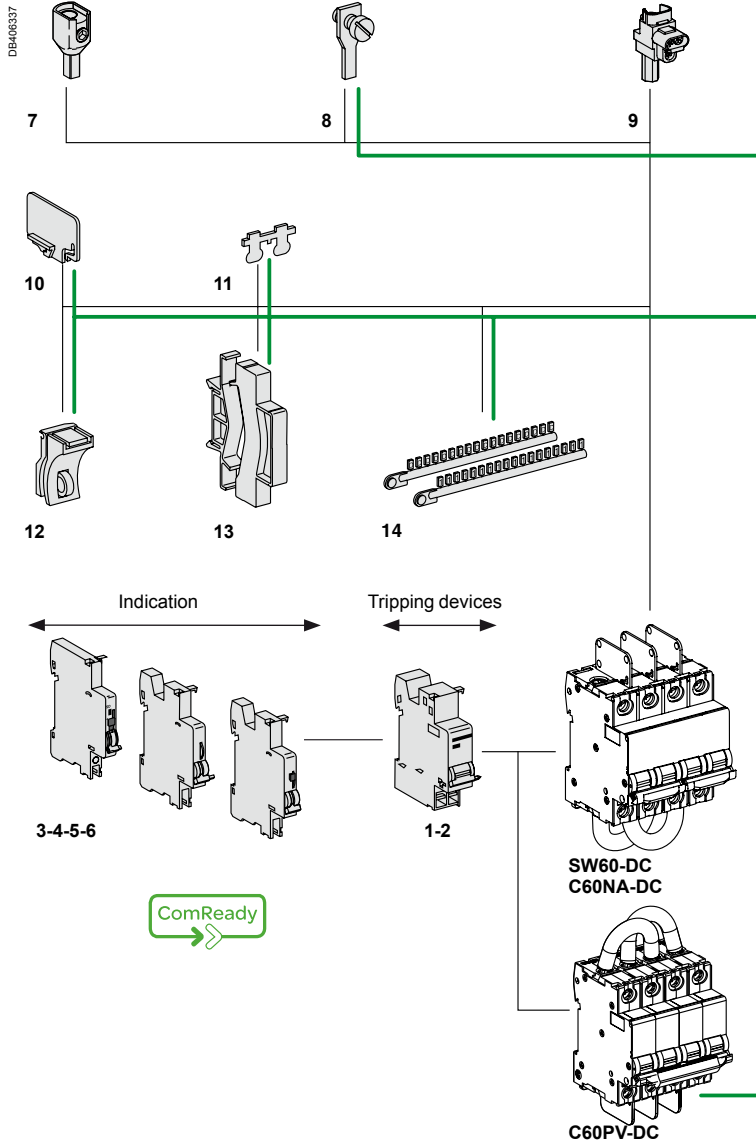

Tripping devices must be installed first.
If two tripping devices are used: the MN must be installed first
Indication auxiliaries: respect specified position for SD functions.

Assembly rule

The mounting order and the number for the various auxiliaries must be complied with.

The tripping auxiliaries MN, MX...) should be mounted first **1** as close as possible to the main device.

Then at the left, the indicating auxiliaries (OF, SD) should be mounted **2** then **3** complying with the following association table.

Indicating auxiliaries 3		Indicating auxiliaries 2		Indicating auxiliaries 1		Device
1 (OF+SD/OF or OF+SD24)	1 OF+SD/OF	1 (MN, MNx, MN \square or MX, MX+OF)				
1 OF	1 (OF+SD/OF or SD or OF)	2 (MN, MNx, MN \square or MX, MX+OF)				
-	1 OF+SD24	2 (MN, MNx, MN \square or MX, MX+OF)				

Protection

Circuit protection / Earth leakage protection

Accessories and auxiliaries for NG125 devices

Connection

6	Comb busbar	see cat. no.	CA907026, CA907027
7	Splitter blocks	Lineryg DX 125 A	see cat. no. LIN003
8	70 mm ² Al terminal		19095
9	Multi-cable terminal	4 parts	19091
		3 parts	19096
10	Screw-on connection for ring	125 A (pack of 4)	19093
11	Small ring terminal	(pack of 4)	19094

DB 123425

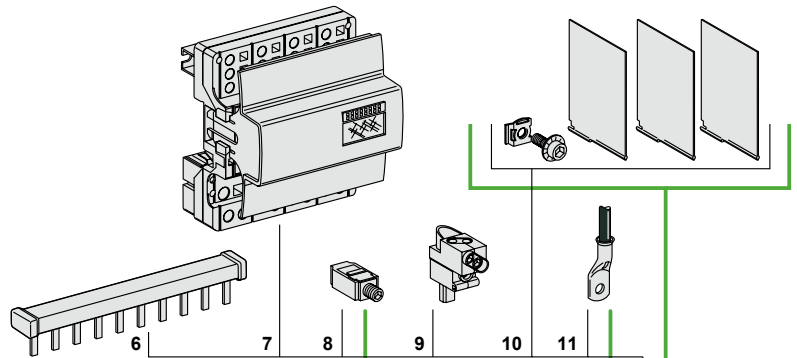

Mounting accessories

12	Sealable terminal shield (upstream/downstream)	1P	19080
		2P	19081
		3P	19082
		4P	19083
13	Residual current device terminal shield (upstream of circuit breaker / downstream of Vigi device)	63 A 2P	19074
		3P	19075
		3P adjustable	19077
		4P	19076
		4P adjustable	19078
14	Circuit breaker screw shield	125 A 3P	19077
		4P	19078
		1P (pack of 10)	19084
		2P	19085
15	Rotary handle	3P	19086
		4P	19087
		Extended standard Black	19088
		Extended safety Red handle, yellow	19089
16	Padlocking device	Direct standard Black	19092
		Direct safety Red handle, yellow background	19097
17	White toggle	(pack of 10)	19099

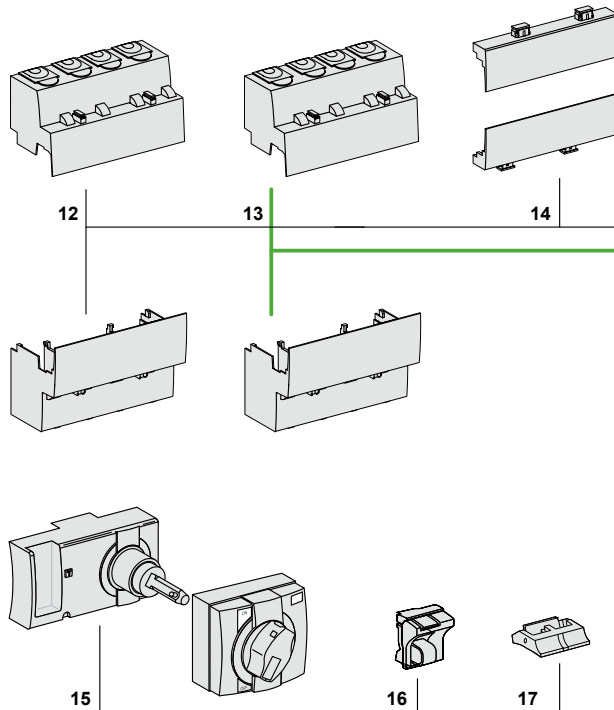

Electrical auxiliaries

Indication		
3	Fault indicating auxiliary contact OF+SD	19072
	Open/closed auxiliary contact OF+OF	19071

Tripping devices		
2	Undervoltage release MN or undervoltage release with external power supply MNx	see cat. no. CM907005
	Shunt release MX+OF	see cat. no. CM907005



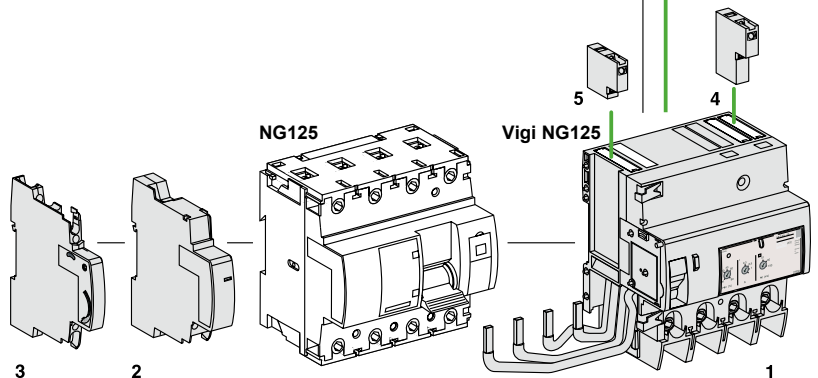

Vigi NG125

1	Vigi NG125 add-on residual current device	see cat. no. CM902008
4	MXV	see cat. no. CM907005
5	SDV	see cat. no. CM907005



Circuit protection / Earth leakage protection





Accessories for iC60, iID, iC40, iCV40, iID40, iSW-NA, Reflex iC60, RCA, iSW

Mounting						
Accessories	Rotary handle			Plug-in base	Padlocking device	
						
						
Function	<p>Front or side-mounted control</p> <ul style="list-style-type: none"> ■ Degree of protection: IP55 rotary handle ■ Installation: <ul style="list-style-type: none"> □ the control mechanism is mounted on the device □ the rotary handle is fixed to the front or side of the enclosure ■ Front-mounted (on door or faceplate) ■ Prevents the door from opening when the device is in the ON position (can be deactivated) ■ Can be padlocked when the device is in the "open" position (can be padlocked with the device in the "closed" position subject to adaptation) ■ Can be locked by padlock of (dia. 5 to 8 mm), not supplied with the device ■ Pushbutton: iID test available in the front face of the rotary handle 			<ul style="list-style-type: none"> ■ The Laser Square tool brings the accuracy to align the breaker and the rotary handle 	<p>Allows a breaker to be removed or replaced quickly, without handling the connections</p> <ul style="list-style-type: none"> ■ Degree of protection: IP20 ■ Consists of: <ul style="list-style-type: none"> □ a base to be fastened on a rail (or panel) □ 2 "blades" to be fastened in the device's terminals ■ Connection: tunnel terminals for cable up to 35 mm² rigid, 25 mm² flexible, ■ Installation: <ul style="list-style-type: none"> □ in universal enclosure □ on horizontal rail ■ Height: 178 mm ■ Not compatible with Vigi iC60 and auxiliaries ■ Can be locked by padlock of (dia. 6 mm), not supplied with the device 	<p>Used to padlock a breaker in open or closed position</p> <ul style="list-style-type: none"> ■ Padlock diameter: 3 to 6 mm ■ Sealable (max. diameter: 1.2 mm) ■ Locking in ON position does not prevent tripping of the breaker in the event of faults ■ Suitable for IEC/EN 60947-2 compliant disconnection
Catalogue numbers	A9A27005	A9A27006	A9A27008	GVAPL01	A9A27003 (1 per pole)	A9A26970
	Operating sub-assembly					
	+	+				
	Black handle	Red handle	No handle			
Set of	1	1	1	1	1	10
Suitability						
iC60	■ 2P, 3P, 4P					■
iSW	■ 2P, 3P, 4P					■
iC60 + Vigi iC60	■ 2P, 3P, 4P					■
iID	■				■ ≤ 63 A	■
iC40, iC40 XA	-					■
iCV40, iCV40 XA	-					■
iDPN Vigi	-					■
iID40	-					■
Reflex iC60 or RCA+iC60 or ARA+iC60	-					■
ARA+iID	-					■
iSW-NA	■				■ ≤ 63 A	■

Protection

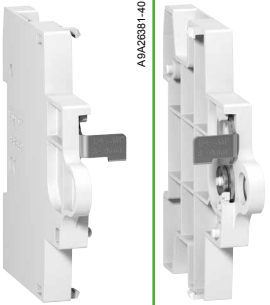
Circuit protection / Earth leakage protection

Accessories for iC60, iID, iC40, iCV40, iID40, iSW-NA, Reflex iC60, RCA, iSW (cont.)



			Spare part			
			Wall mounting	Locking clips	Flap	
Side					2P	4P
A9A26380-40	A9A26381-40	PE104492-15	A9A27052-25	A9A27056-15	A9A27057-15	
						
<p>Can be used to padlock a breaker in open position</p> <ul style="list-style-type: none"> Attached directly to the circuit breaker, it cannot be lost Padlock diameter: 6 mm 		<p>Can be used for wall mounted installation of any 18 mm DIN rail devices</p> <ul style="list-style-type: none"> Degree of protection: IP40 Sealable: (max. diameter: 1.5 mm) 	<p>Top and bottom locking clips for monoconnect product</p>	<p>Indication flap of connection direction</p>		
A9A26380	A9A26381	15359	A9A27052	A9A27056	A9A27057	
Left-hand mounting	Right-hand mounting					
1	1	1	10	1	1	
■	■	■ All products up to 18 mm	■	-	-	-
-	-	■ Except ICT	-	-	-	-
-	-		-	-	-	-
■	-		-	-	-	-
■	■ (1)		■	-	-	-
■	-		■	-	-	-
-	-		-	-	-	-
■	-		■	■	■	■
-	-		-	-	-	-
-	-		-	-	-	-
-	-		-	-	-	-

(1) iC40 XA compatible only with bottom screw connections.

Protection

Circuit protection / Earth leakage protection





Accessories for iC60, iID, iC40, iCV40, iID40, iDPN Vigi, iSW-NA, Reflex iC60, RCA, ARA, iSW (cont.)

Security						
Accessories	Screw shield		Terminal shield		Inter-pole barrier	Spacer
 PB104489-14	 PB104489-14	 PB104489-14	 PB104489-14	 PB104502-35	 PB104503-35	 PB104484-30
	 PB104484-30					
Function						
	Prevents any contact with the connecting screws <ul style="list-style-type: none"> Upgrades degree of protection to IP20D Sealable, max. diameter 1.2 mm 		Prevents any contact with the terminals <ul style="list-style-type: none"> Upgrades degree of protection to IP20D Sealable, max. diameter 1.2 mm Set of two, for power supply and output terminals For 3 poles: A9A26975 + A9A26976 For 4 poles: 2 X A9A26976 		Enhances insulation between connections: cables, terminals, lugs, etc	<ul style="list-style-type: none"> Used to: <ul style="list-style-type: none"> complete rows separate devices. Width: 1 x 9 mm module Allows cable routing from one row to another, (above and below), up to 6 mm²
Catalogue numbers	A9A26982	A9A26981	A9A26975	A9A26976	A9A27001	A9A27062
Set of	12 x 1 pole	20 x 4 poles (splittable)	2 x 1 pole	2 x 2 poles	10	5
Suitability						
iC60	-	■	■	■	■	■
iSW	-	-	■	■	■	■
Vigi iC60	■	-	-	-	-	■
Vigi iC40, Vigi iCG40	-	-	-	-	-	■
iID	-	■	-	■	■	■
iC40, iC40 XA	-	-	-	-	-	■
iCV40, iCV40 XA	-	-	-	-	-	■
iDPN Vigi	-	-	-	-	-	■
iID40	-	■ (2)	-	■ (2)	■ only on power supply terminals (bottom)	■
Reflex iC60 or RCA+iC60 or ARA+iC60	-	■	■	■	■	■
ARA+iID	-	■	-	■	■	■
iSW-NA	-	■	-	■	■	■

(2) compatible only with power supply terminals (bottom), having removed the indication flap of connection direction.

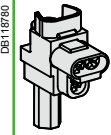
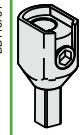
Circuit protection / Earth leakage protection

Accessories for iC60, iID, iC40, iCV40, iID40, iSW-NA, Reflex iC60, RCA, iSW (cont.)

		Connection			
Accessories		Multi-cable terminal		50 mm ² Al terminal	Screw-on connection for ring terminal
					
Function		For 3 copper cables: ■ Rigid up to 16 mm ² ■ Flexible up to 10 mm ²		For aluminium cables from 16 to 50 mm ²	For lug tipped cables, front or rear mounting
					
Catalogue numbers	19091	19096		27060	27053
Set of	4	3		1	8
Suitability					
iC60 ≤ 25 A Reflex iC60 ≤ 25 A	–	–		–	■
iC60 >25 A Reflex iC60 40 A, iSW	■	■		■	■
Vigi iC60	–	–		–	–
iID	■	■		■	■
iC40, iC40 XA	–	–		–	■ (3)
iCV40, iCV40 XA	–	–		–	■ (4)
iDPN Vigi	–	–		–	■
iID40	■ only on power supply terminals (bottom)	■ only on power supply terminals (bottom)		■ only on power supply terminals (bottom)	■
iSW-NA	■	■		■	■
Tightening torque	2 N.m			10 N.m	2 N.m
Length stripping	11 mm			13 mm	–
Tools to use	Dia. 5 mm or PZ2			Hc 1/5" or 5 mm	Dia. 5mm

(3) only with screw connections.

(4) only with screw connections on MCB side and on Vigi side for iCV40 1P+N.

Marking

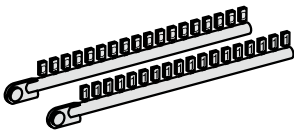
Accessories		Clip-on terminal markers					
							
		Used for connection identificatio					
Catalogue numbers	0 : AB1-R0 1 : AB1-R1 2 : AB1-R2 3 : AB1-R3 4 : AB1-R4	5 : AB1-R5 6 : AB1-R6 7 : AB1-R7 8 : AB1-R8 9 : AB1-R9	A : AB1-GA B : AB1-GB C : AB1-GC D : AB1-GD E : AB1-GE F : AB1-GF G : AB1-GG H : AB1-GH I : AB1-GI	J : AB1-GJ K : AB1-GK L : AB1-GL M : AB1-GM N : AB1-GN O : AB1-GO P : AB1-GP Q : AB1-GQ R : AB1-GR	S : AB1-GS T : AB1-GT U : AB1-GU V : AB1-GV W : AB1-GW X : AB1-GX Y : AB1-GY Z : AB1-GZ	+ : AB1-R12 - : AB1-R13 Blank: AB1-RV	
Set of	250						

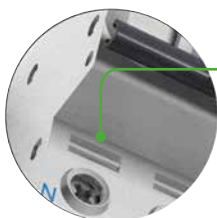

■ 4 markers max. per zone

Protection

Circuit protection / Earth leakage protection

Accessories for iC60, iID, iC40, iCV40, iID40, iSW-NA, Reflex iC60, RCA, iSW (cont.)

Dimensions (mm)

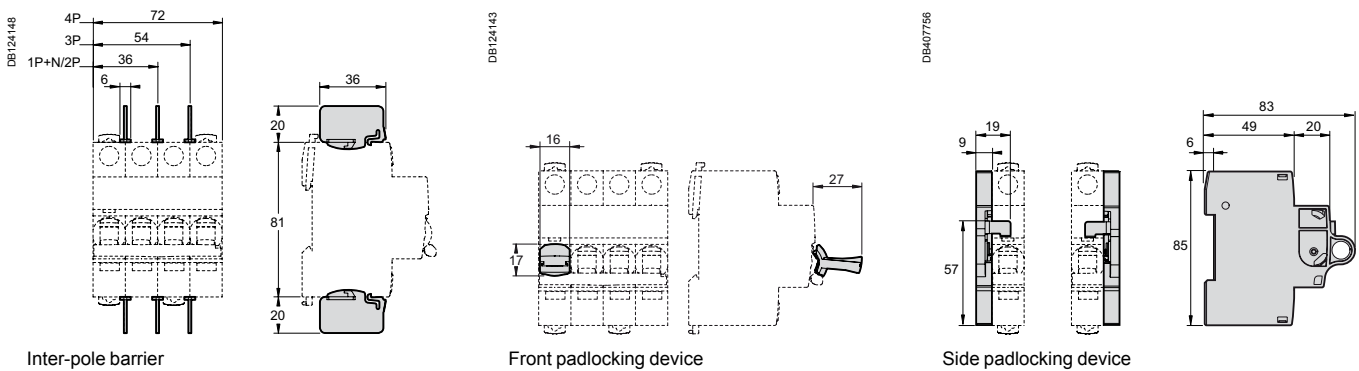
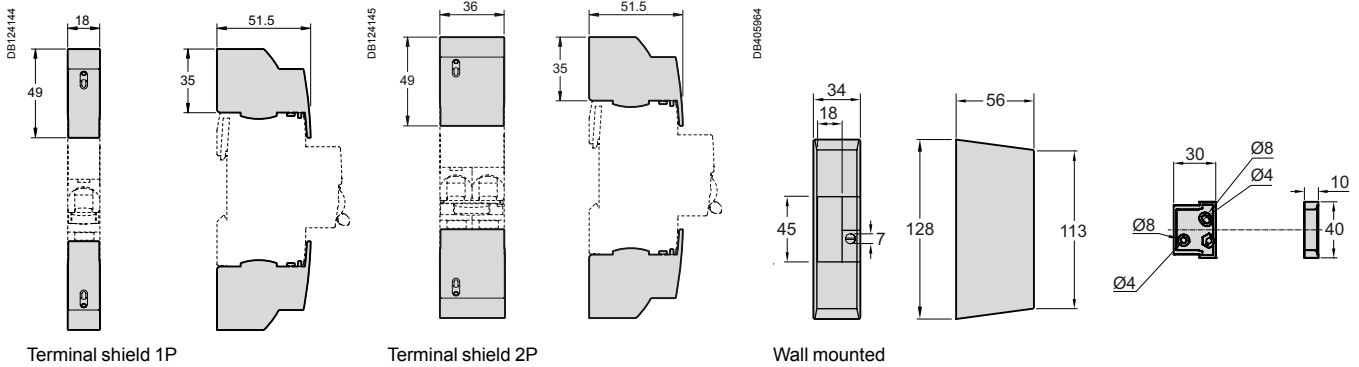
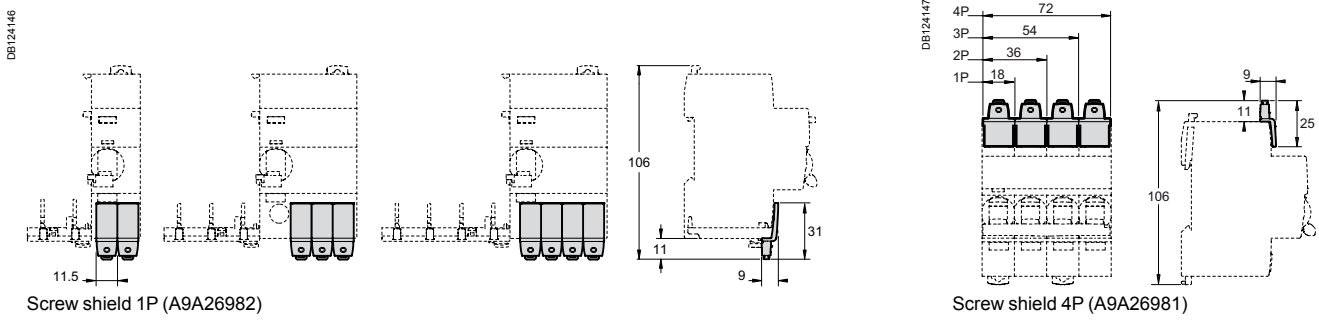
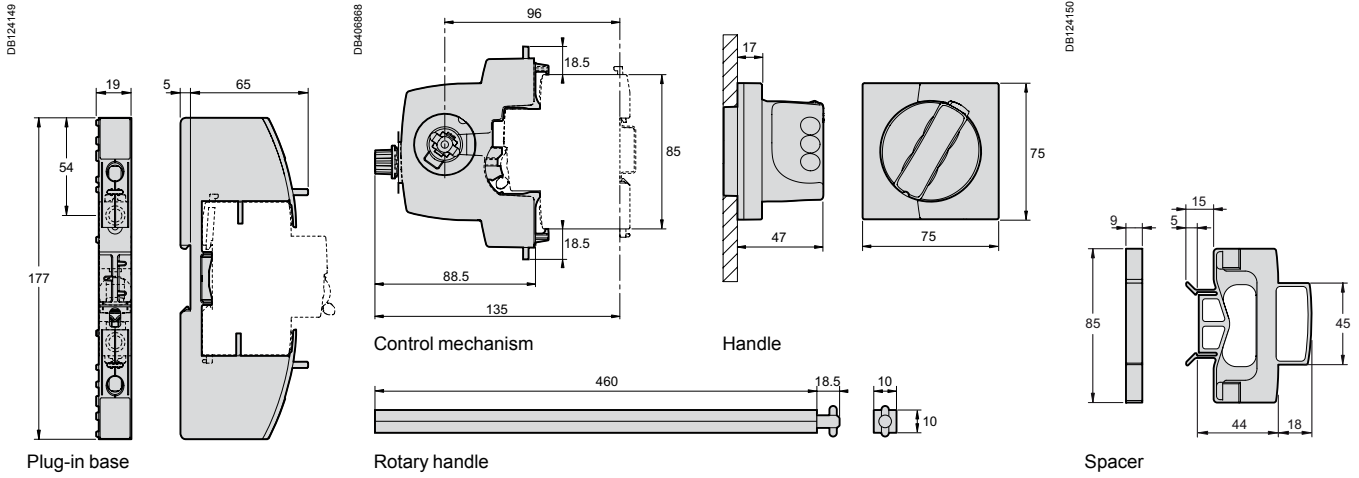

Protection

Circuit protection / Earth leakage protection

Accessories for iC60, iID, iC40, iCV40, iID40, iSW-NA, Reflex iC60, RCA, iSW (cont.)

Rotary handle installation

Dimensions (mm)

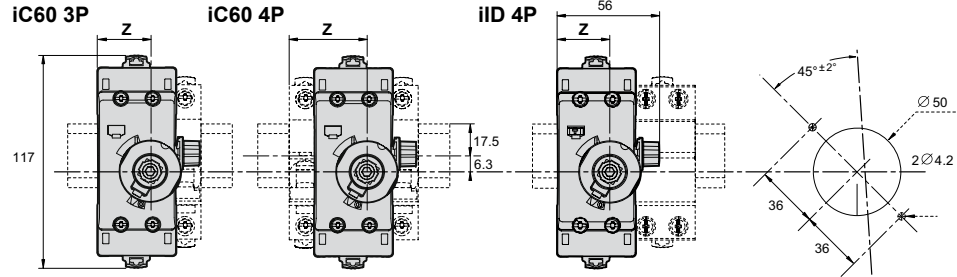
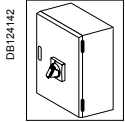

iC60	Z (mm)
2P	25.3
2P + Vigi	25.3
3P	25.3
3P + Vigi	43
4P	43
4P + Vigi	43

iID	Z (mm)
2P	25.3
4P	25.3

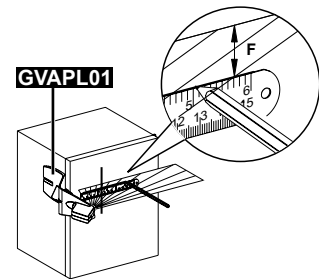
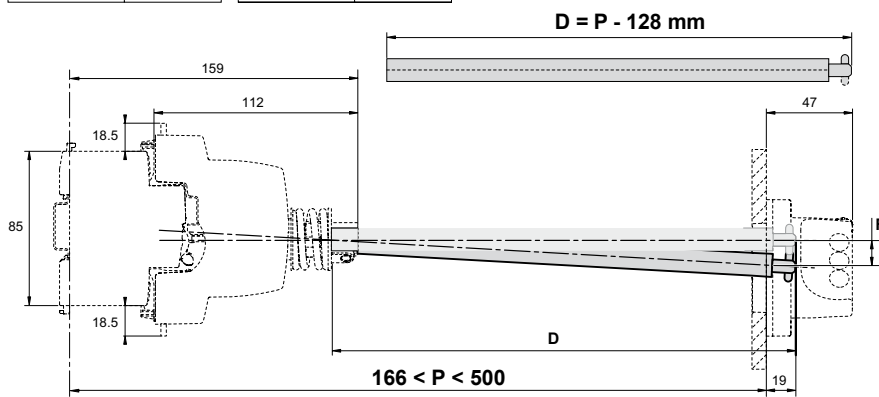

P (mm)	F (mm)
300	5
500	11

Rotary handle: front mounted control

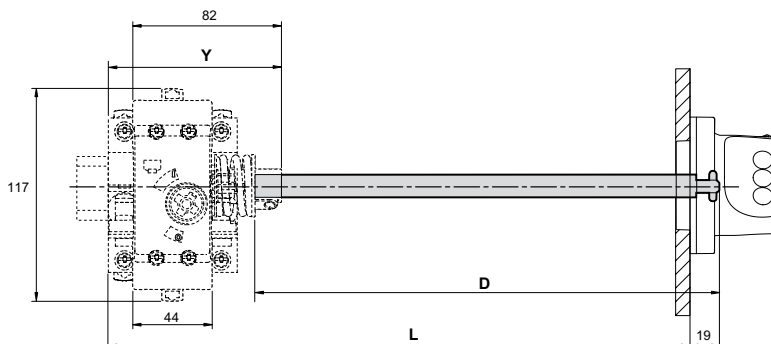
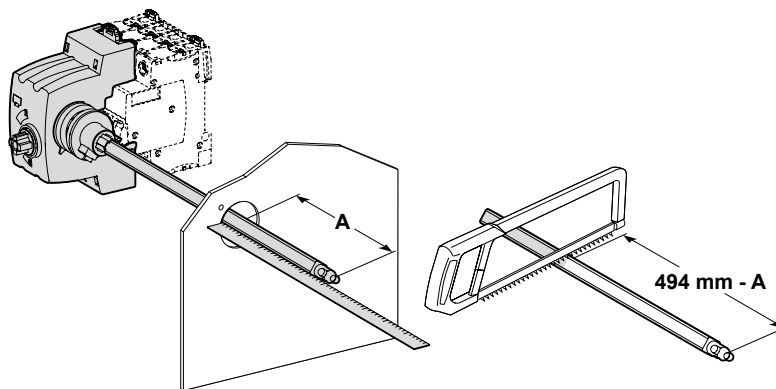
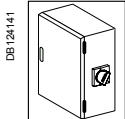

iC60	X (mm)	Y (mm)
2P	44.5	76.8
2P + Vigi	44.5	76.8
3P	44.5	76.8
3P + Vigi	62	94.5
4P	62	94.5
4P + Vigi	62	94.5

iID/iSW-NA	X (mm)	Y (mm)
2P	44.5	76.8
4P	44.5	76.8



Rotary handle: side mounted control

Accessories for C60, C120, C60H-DC, SW60-DC, C60NA-DC, C60PV-DC, ID, iSW devices

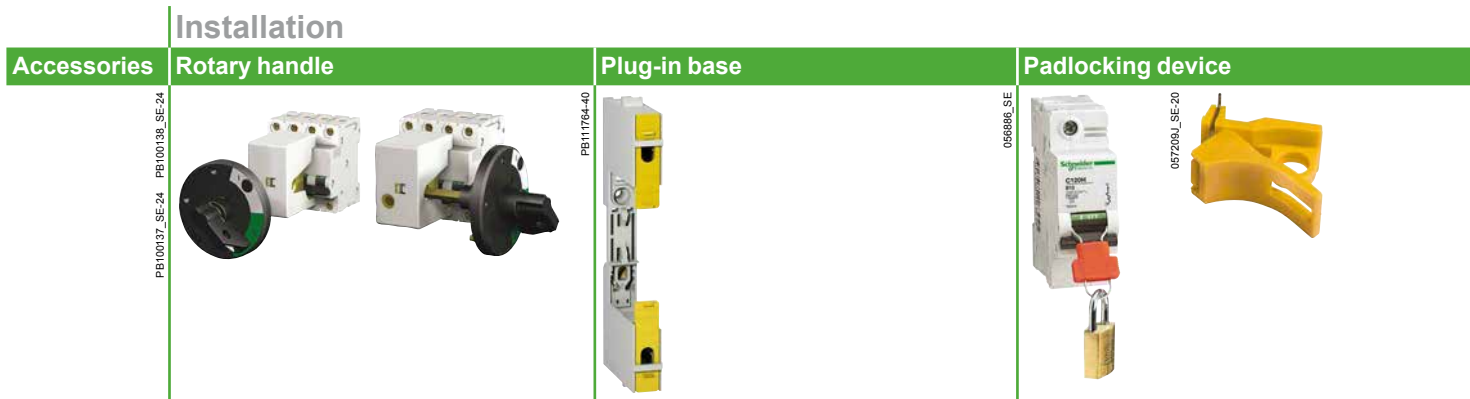





Function								
	<p>Front or side control of 2, 3 and 4-pole circuit breakers</p> <ul style="list-style-type: none"> Degree of protection: IP40 A complete rotary handle consists of: <ul style="list-style-type: none"> a circuit-breaker operating sub-assembly, cat. no. 27046, a handle cat. no. 27047 or a handle cat. no. 27048 Installation: <ul style="list-style-type: none"> the circuit-breaker operating sub-assembly cat. no. 27046 is fixed to the circuit breaker the removable handle cat. no. 27047 is mounted on the removable front panel or on the enclosure door the fixed handle cat. no. 27048 is fixed to the front or side panel of the enclosure 			<p>Allows a circuit breaker to be quickly removed or replaced, without touching the connections</p> <ul style="list-style-type: none"> Degree of protection: IP20 It consists of: <ul style="list-style-type: none"> a base to be fixed to a rail (or panel) 2 "blades" to be fixed in the device terminals Connection: tunnel terminals for cables up to 50 mm² (rigid) or 35 mm² (flexible) Installation: <ul style="list-style-type: none"> on backplate on a horizontal rail Centreline between two rows: 200 mm Only on the circuit breaker, without a Vigi device or auxiliary Padlocking option (8 mm dia. padlock not supplied) 		<p>Used to padlock a circuit breaker in the "open" or "closed" position</p> <ul style="list-style-type: none"> Diameter of the padlock: 8 mm max. Locking in the ON position does not prevent the circuit breaker from tripping in the event of a fault Isolation: in conformity with IEC/EN 60947-2. 		
Cat. numbers	27047 Removable extended handle	27048 Fixed handle	27046 Operating sub-assembly	26996 (1 per pole)	26997 (1 per pole)	27145	26970	
Set of	1	1	1	1	1	4	2	









Suitable for the following devices:

C60	<ul style="list-style-type: none"> 2P, 3P, 4P 						
C120, C120NA-DC	<ul style="list-style-type: none"> 2P, 3P, 4P 				<ul style="list-style-type: none"> ≤ 63 A 		
C120 + Vigi C120	<ul style="list-style-type: none"> 2P, 3P, 4P 						
DPN, DPN Vigi	<ul style="list-style-type: none"> 3P, 4P 						
C60H-DC	<ul style="list-style-type: none"> 2P 						
SW60-DC, C60NA-DC, C60PV-DC							
ID				<ul style="list-style-type: none"> ≤ 63 A 			
iSW	<ul style="list-style-type: none"> iSW ≥ 4 modules of 9 mm 			<ul style="list-style-type: none"> iSW 40 to 63 A 			

Accessories for C60, C120, C60H-DC, SW60-DC, C60NA-DC, C60PV-DC, ID, iSW devices (cont.)

Safety							
Accessories	Screw shield		Terminal shield		Interpole barrier	Spacer	
							
	056870_SE-33	PE124114	056889_SE-38		DE123898	PE104485-35	
Function	Prevents all contact with the fixing screws <ul style="list-style-type: none"> The degree of protection becomes IP40 Sealable, max. diameter 1.2 mm Dividable 		Prevents all contact with the terminals <ul style="list-style-type: none"> Degree of protection becomes IP40 Sealable, max. diameter 1.2 mm 		Improves the insulation between the connections: cables, terminals, lugs, etc.		<ul style="list-style-type: none"> Used to: <ul style="list-style-type: none"> complete the rows separate the devices Width: 1 x 9 mm module Allows that 2 cables are routed from one row to another (above and below), up to 6 mm²
			<ul style="list-style-type: none"> 1P 1P 2P 3P: 1 x 26975 + 1 x 26976 4P: 2 x 26976 				
Cat. numbers	18527	26981	18526	26975	26976	27001	A9N27062
Set of	2 (4P dividable)		2 (for upstream/downstream terminal)		10	1	
Suitable for the following devices:							
C60	-	■	-	■	■	■	■
C120, C120NA-DC	■	-	■	-	-	■	■
Vigi C120	-	-	-	-	-	-	■
DPN, DPN Vigi	-	-	-	-	-	-	■
C60H-DC	-	■	-	■	■	■	■
SW60-DC, C60NA-DC, C60PV-DC	-	■	-	-	-	■	■
ID	-	■	-	■	■	■	■
iSW	-	■ iSW 40 to 125 A	-	■ iSW 40 to 125 A	■ iSW 40 to 125 A	■ iSW 40 to 125 A	■

Accessories for C60, C120, C60H-DC, SW60-DC, C60NA-DC, C60PV-DC, ID, iSW devices (cont.)

		Connection				
Accessories	Multi-cable terminal	50 mm ² Al terminal	Screw-on connection for ring terminal	Connection kit for ring terminals	Terminal for rear connector	
						
Function		For 3 copper cables: ■ Rigid up to 16 mm ² ■ Flexible up to 10 mm ²	For 16 to 50 mm² aluminium cables	For lug tipped cables, front or rear mounting	For terminal up to 63 A, front or rear access (screw Ø 5 mm) ■ It incorporates a "conductive" part and an "insulating" part which ensures the phase-to-phase clearance	For cable up to 50 mm² or by terminal ■ Supplied with a 1P terminal shield
						
Cat. numbers	19091	19096	27060	27053	17400	18528
Set of	4	3	1	8	2	2
Suitable for the following devices:						
C60 ≤ 25 A	–	–	–	■	■	–
C60 > 25 A	■	■	■	■	■	–
C120, C120NA-DC	■	■	■	■	–	■
Vigi C120	–	–	–	–	–	–
DPN, DPN Vigi	–	–	–	■	–	–
C60H-DC, ID	■	■	■	■	■	–
iSW 40 to 125 A	–	–	–	–	–	–
SW60-DC, C60NA-DC	■	■	■	■	–	–
C60PV-DC	–	–	–	■	–	–
Tightening torque	2 N.m		10 N.m	2 N.m		–
Stripping length	11 mm		13 mm	–		–
Tools to be used	Diameter 5 mm or PZ2		Hc 1/5" or 5 mm	Diameter 5 mm		13 mm spanner

		Identification	
Accessories	Clip-on terminal marker strip		
			
Function		For connection identification	
Cat. numbers		0: AB1-R0 1: AB1-R1 2: AB1-R2 3: AB1-R3 4: AB1-R4 5: AB1-R5 6: AB1-R6 7: AB1-R7 8: AB1-R8 9: AB1-R9	A: AB1-GA B: AB1-GB C: AB1-GC D: AB1-GD E: AB1-GE F: AB1-GF G: AB1-GG H: AB1-GH I: AB1-GI J: AB1-GJ
		K: AB1-GK L: AB1-GL M: AB1-GM N: AB1-GN O: AB1-GO P: AB1-GP Q: AB1-GQ R: AB1-GR S: AB1-GS T: AB1-GT	U: AB1-GU V: AB1-GV W: AB1-GW X: AB1-GX Y: AB1-GY Z: AB1-GZ +: AB1-R12 -: AB1-R13 Blank : AB1-RV
Set of	250		
Suitable for the following devices:			
C60, ID	■ 4 markers max. per pole		
C120, C120NA-DC	■ 4 markers max. per pole		
Vigi C120	■ 4 markers max. per device		
DPN, DPN Vigi	■ 4 markers max. per pole		
C60H-DC, SW60-DC, C60NA-DC, C60PV-DC	■ 4 markers max. per pole		

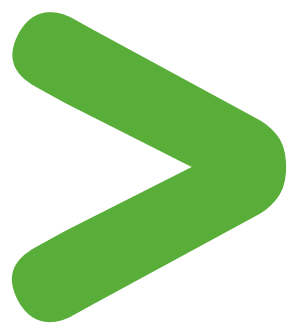

Protection

Circuit protection

Earth leakage protection

Accessories for NG125 devices

		Mounting			
Accessories	Rotary handle		Toggle	Padlocking device	
Function					
	Extended rotary handle <ul style="list-style-type: none"> Degree of protection: rotary button IP55 Front installation: Prevents door opening when the circuit breaker is in position O Keeps disconnection Padlocking possible when the device is in position O Padlock diameter: 3 to 6 mm 		Direct rotary handle <ul style="list-style-type: none"> Front installation Keeps disconnection Padlocking possible when the device is in position O Padlock diameter: 3 to 6 mm 		White toggle <ul style="list-style-type: none"> Allows visual distinction of a switchboard incoming device
			<ul style="list-style-type: none"> Two versions: <ul style="list-style-type: none"> standard black red handle and yellow front plate for machine tool control 		Allows padlocking: <ul style="list-style-type: none"> In position I or O of NG125 1P or 2P circuit breakers In position I of NG125 3P or 4P circuit breakers or switches Padlock: dia. 5 to 8 mm (not supplied) <p>Note: NG125 3P/4P circuit breakers and switches are provided with padlocking in position O (disconnected) as original equipment.</p>
Catalogue numbers	19088 Extended standard black	19089 Extended safety	19092 Direct standard black	19097 Direct safety red handle yellow background	19099 White toggle
Pack of	1		1	1	10
Suitable for the following devices:					
NG125	<ul style="list-style-type: none"> 3P, 4P 				<ul style="list-style-type: none"> 3P, 4P
Vigi NG125	-		-	-	-

		Connection			
Accessories	Multi-cable terminal	70 mm ² Al terminal	Screw-on connection for ring terminal	Small ring terminal	
Function					
	For 3 copper cables: <ul style="list-style-type: none"> Rigid up to 16 mm² Flexible up to 10 mm² 	For single rigid aluminium cables from 25 to 70 mm²	Installation: <ul style="list-style-type: none"> Upstream or downstream Connection ratings 80 to 125 A: <ul style="list-style-type: none"> copper terminal: <ul style="list-style-type: none"> flexible cable up to 35 mm² rigid cable up to 50 mm² bars: 16 x 3 mm, 15 x 4 mm, 16 x 4 mm small ring terminal Phase-to-phase insulation voltage: U_i = 1000 V 	Connection ratings 80 to 125 A: <ul style="list-style-type: none"> Flexible copper cable: 50 mm² Rigid copper cable: 70 mm² 	
Cat. nos.	19091	19096	19095	19093	19094
Pack of	4	3	4	4	4
NG125			<ul style="list-style-type: none"> 3P, 3P+N, 4P: 80, 100, 125 A 	<ul style="list-style-type: none"> 80, 100, 125 A 	<ul style="list-style-type: none"> 80, 100, 125 A
Vigi NG125	-	-	<ul style="list-style-type: none"> 125 A 	<ul style="list-style-type: none"> 125 A 	<ul style="list-style-type: none"> 125 A
Tightening torque	2 N.m		6 N.m	6 N.m	6 N.m
Stripping length	11 mm		-	-	-
Tools to be used	Diameter 5 mm or PZ2		Hc 4 mm	Hc 4 mm	-

Protection

Circuit protection

Earth leakage protection

Accessories for NG125 devices (cont.)

Safety

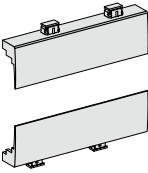
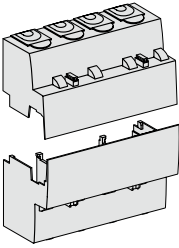
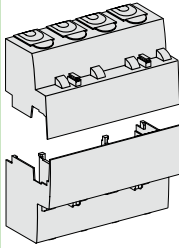
Accessories	Screw shield				Circuit breaker terminal shield				RCD terminal shield						
															
Function	<ul style="list-style-type: none"> ■ Prevents any contact with the connection screws ■ Protection against direct contact: <ul style="list-style-type: none"> □ IP40: on front panel □ IP20: at the connection level ■ Class II in steel or plastic enclosures ■ Sealing possible (max. diameter: 1.2 mm). 				<ul style="list-style-type: none"> ■ Prevents any contact with the terminals ■ Installation: mounted upstream and downstream of circuit breaker ■ Phase-to-phase insulation voltage $U_i = 1000\text{ V}$ ■ Protection against direct contact IP40 ■ Class II in steel or plastic enclosures (up to 440 V) ■ Sealing possible (max. diameter: 1.2 mm) 				<ul style="list-style-type: none"> ■ Installation: is mounted upstream of the circuit breaker and downstream of the Vigi device ■ Phase-to-phase insulation voltage $U_i = 1000\text{ V}$ ■ Protection against direct contact: IP40 ■ Class II in steel or plastic enclosures (up to 440 V) ■ Sealing possible (max. diameter: 1.2 mm) 						
	1P	2P	3P	4P	1P	2P	3P	4P	63 A				125 A		
									2P	3P	3P adjustable	4P	4P adjustable	3P	4P
Catalogue numbers	19084	19085	19086	19087	19080	19081	19082	19083	19074	19075	19077	19076	19078	19077	19078
Pack of	10				Set of 1 upstream / 1 downstream				Set of 1 upstream / 1 downstream						
Suitable for the following devices:															
NG125	■				■				■						
Vigi NG125	-				-				■						

Acti9 VDIS vertical distribution blocks 125 A



A9XPK707



A9XPK714

IEC/EN 60947-7-1

IEC/EN 61439-2

As per the above standards:



Description

- 4P distribution blocks with quick connections.
- Designed for both rigid cables and flexible cables with or without ferrules.
- Push-in technology.
- Optimised installation in Pragma 24 (surface mounting), Resi9 24 (surface mounting), Prisma G and Prisma Pack.
- Only two versions to cover all configurations.

Technical data

	4P	4P
Number of poles	4P	4P
Operating current at 40°C (Ie)	125 A	125 A
Operating voltage (Ue)	250/440 V AC	250/440 V AC
Operating frequency	50/60 Hz	50/60 Hz
Rated insulation voltage (Ui)	500 V AC	500 V AC
Rated impulse withstand voltage (Uimp)	6 kV	6 kV
Rated peak withstand current at 20 ms (Ipk)	20 kA	20 kA
Rated conditional short-circuit current withstand (Isc)	Up to breaking capacity of Schneider Electric outgoing circuit breakers, Acti9 iC60 and Acti9 iC40, even when reinforced by cascading implementation	
Pollution degree	3	3
Degree of protection	IPxxB	IPxxB
Total connection capacity at outgoing terminals	7 for each phase 12 for neutral	14 for each phase 24 for neutral
Weight (g)	1140	2040
Catalog numbers	A9XPK707	A9XPK714

Accessories

Type	Accessory	Spare parts
		
Designation	Prisma vertical mounting accessories	Locking clips for Pragma installation
Set of	4	10
Catalog numbers	A9XPKV04	A9XPKL10

Dimensions (mm)

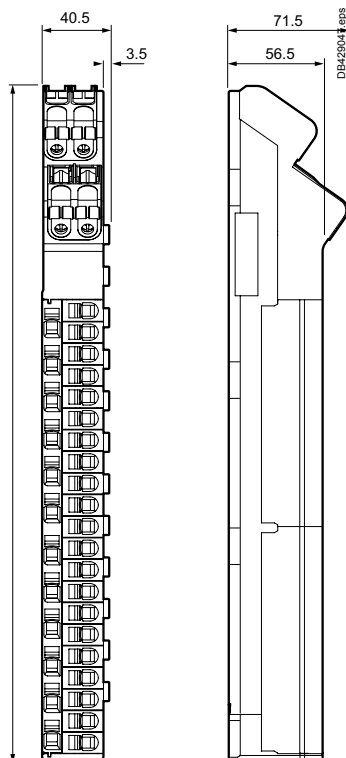

A9XPK707: 408

A9XPK714: 680

Selection Guide

Mounting type	A9XPK707		A9XPK714	
	Direct	with A9XPKV04 accessory	Direct	with A9XPKV04 accessory
Pragma 24, surface mounted enclosures				
1, 2, 3 rows	-	-	-	-
4, 5 rows	■	-	-	-
6 rows	■	-	■	-
Resi9 24, surface mounted enclosures				
3 rows	-	-	-	-
4, 5 rows	■	-	-	-
6 rows	■	-	■	-
Prisma G				
< 12 modules	-	-	-	-
≥ 12 and < 18 modules	-	■	-	-
≥ 18 modules	-	■	-	■
Prisma Pack				
< 4 rows	-	-	-	-
≥ 4 and < 6 rows	-	■	-	-
≥ 6 rows	-	■	-	■

Acti9 VDIS vertical distribution blocks 125 A

Advantages

- High reliability of cabling thanks to spring terminals.
- Fast and simplified distribution thanks to a direct and frontal access to head of groups and groups of devices.
- Space release on Din Rail thanks to side installation.
- Time saving thanks to screwless and push-in technology.
- Easy phase balancing.
- Easy extensions and modifications.
- Numerous Ph+N load connections.

Power supply

- Four-poles tunnel terminals with screw clamping
- Cable per connection point:
 - flexible from 10 to 35 mm²
 - flexible with insulated ferrule from 10 to 35 mm²
 - stranded from 10 to 35 mm²

Distribution connections

- Connection to spring terminals through the front
- A single cable per connection point:
 - rigid from 1.5 to 10 mm²
 - stranded from 4 to 16 mm²
 - flexible from 1.5 to 16 mm²
 - flexible with ferrule from 1.5 to 16 mm²
- Push-in spring for toolless connection for both rigid and flexible cables with ferrules
- Maintenance free
- Connections:
 - A9XPK707: 7 per phase, 12 neutral
 - A9XPK714: 14 per phase, 24 neutral

Installation

- Clip-on directly in Pragma supports, locking clips included
- Clip-on in Prisma vertical mounting accessories A9XPKV04

Stripping length

- Rigid or flexible

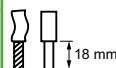

Flexible with ferrule

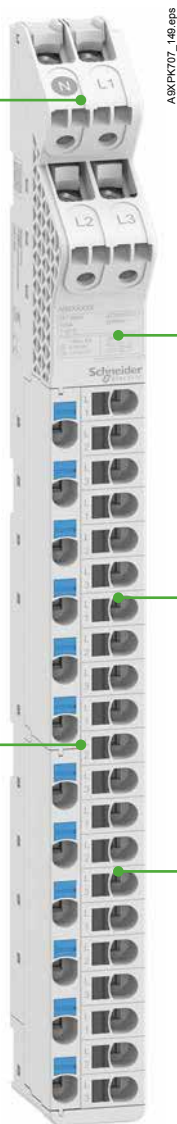

Horizontal comb busbars 18 mm modules for Acti9: iC60



Acti9 iC60, iK60					
18 mm poles, cuttable					
Number of poles	1P	1P+N	3P	4P	3 (N+P)
Type	L1, ...	NL, ...	L1L2L3, ...	NL1L2L3, ...	NL1NL2NL3, ...
Set of	1	1	1	1	1
Catalogue numbers					
6 modules of 18 mm	A9XPH106	A9XPH206 (*)	A9XPH306	-	-
8 modules of 18 mm	-	A9XPH208 (*)	-	A9XPH408	-
9 modules of 18 mm	-	-	A9XPH309	-	-
10 modules of 18 mm	-	A9XPH210 (*)	-	-	-
12 modules of 18 mm	A9XPH112	A9XPH212 (*)	A9XPH312	A9XPH412	A9XPH512
16 modules of 18 mm	-	-	A9XPH316	A9XPH416	-
18 modules of 18 mm	-	A9XPH218 (*)	A9XPH318	-	A9XPH518
20 modules of 18 mm	-	-	A9XPH320	-	-
24 modules of 18 mm	A9XPH124	A9XPH224 (*)	A9XPH324	A9XPH424	A9XPH524
57 modules of 18 mm	A9XPH157	A9XPH257 (*)	A9XPH357	A9XPH457	A9XPH557

(*) **CAUTION**
INCOMPATIBILITY BETWEEN TWO-POLE COMB BUSBARS AND FOUR-POLE DEVICES
 - Never connect a two-pole busbar to a four-pole device, as this will result in a multi-phase bolted short circuit.
 - Always check that the head of group circuit breaker is in good working condition before connecting a comb busbar.
Failure to follow these instructions can result in injury or equipment damage.

Technical data	
Operating current (Ie) at 40°C	100 A
Short circuit current (Isc)	Compatible with the breaking capacity of Schneider Electric circuit breakers
Rated insulation voltage (Ui)	500 V AC
Operating voltage (Ue)	415 V AC
Pollution degree	3
Fire resistance IEC 60695-2-1	Self-extinguishing at 960°C 30 secondes
Color	RAL9003

Horizontal comb busbars 18 mm modules for Acti9: iC60



Cuttable comb busbars, 18 mm modules, with 9 mm auxiliary					
Aux+1P	Aux+2P	Aux+3P	Aux+4P	3 (Aux+1P)	3 (Aux+N+1P)
AuxL 1, ...	AuxL 1L2, ...	AuxL 1L2L3, ...	AuxNL 1L2L3, ...	AuxL 1AuxL2AuxL3, ...	AuxNL 1AuxNL2AuxNL3, ...
1	1	1	1	1	1
-	-	-	-	-	-
-	-	-	-	-	-
-	-	-	-	-	-
-	-	-	-	-	-
-	-	-	-	-	-
-	-	-	-	-	-
-	-	-	-	-	-
-	-	-	-	-	-
-	-	-	-	-	-
A9XAH157	A9XAH257	A9XAH357	A9XAH457	A9XAH657	A9XAH557



Accessories						
Number of poles	1P Aux+1P	1P+N Aux+2P	3P Aux+3P 3 (Aux+1P)	4P/3 (N+P) Aux+4P 3 (Aux+N+1P)	-	-
	End-pieces				Tooth covers	Connectors
	Lateral end-pieces providing IP20 protection				Insulate teeth that have been left free	Monoconnect Comb busbar power supply. Horizontal in-comer on each side. For 35 mm ² cable. Tightening torque 4 N.m
Set of	10	10	10	10	20	4
Catalogue numbers	A9XPE110	A9XPE210	A9XPE310	A9XPE410	A9XPT920	A9XPCM04

Complementary technical information

Horizontal comb busbars 18 mm modules for Acti9: iC60 + Vigī iC60



IEC 60947-7-1, IEC 61439-2



Acti9 Vigī iC60 1P+N	18 mm poles, cuttable	
Number of poles	3 (N+P)	
Type	NL1NL2NL3, ...	NL1NL2NL3, ...
Set of	1	1
Rating of Vigī	25 A	40 A - 63 A
Catalogue numbers		
21 modules of 18 mm	A9XPF521	-
24 modules of 18 mm	-	A9XPF524

Technical data	
Operating current at (Ie) 40°C	100 A
Short circuit current (Isc)	Compatible with the breaking capacity of Schneider Electric circuit breakers
Rated insulation voltage (Ui)	500 V AC
Operating voltage (Ue)	415 V AC
Pollution degree	3
Fire resistance IEC 60 695-2-1	Self-extinguishing at 960°C 30 secondes
Color	RAL9003



End-pieces
■ insulate end of comb busbar

Accessories			
Number of poles	3 (N+P)	-	-
	End-pieces	Tooth covers	Connectors
	Lateral end-pieces providing IP20 protection	Insulate teeth that have been left free	Monoconnect Comb busbar power supply. Horizontal in-comer on each side. For 35 mm ² cable. Tightening torque 4 N.m
Set of	10	20	4
Catalogue numbers	A9XPE410	A9XPT920	A9XPCM04

Horizontal comb busbars 9 mm modules for Acti9: iC40, iCV40, Vigi iC40



IEC 61439-1

Acti9 iC40, iC40 XA, iCV40, iCV40 XA, iDPN, iDPN Vigi, Vigi iC40, Vigi iCG40		9 mm poles, cuttable					
Number of poles		1P+N			3 (N+P)		
Number of 18 mm modules		12	24	48	12	24	48
Supplied accessories	Tooth covers (for 3 modules of 18 mm)	1	2	-	1	2	-
	End-pieces	4	4	-	4	4	-
Catalogue numbers		A9XPC612 (*)	A9XPC624 (*)	A9XPC648 (*)	A9XPC712	A9XPC724	A9XPC748

(*) **CAUTION**
INCOMPATIBILITY BETWEEN TWO-POLE COMB BUSBARS AND FOUR-POLE DEVICES
 - Never connect a two-pole comb busbar to a four-pole device, as this will result in a multi-phase bolted short circuit.
 - Always check that the head of group circuit breaker is in good working condition before connecting a comb busbar.
Failure to follow these instructions can result in injury or equipment damage.

Acti9 iC40, iC40 XA, iCV40, iCV40 XA, iDPN, iDPN Vigi, Vigi iC40, Vigi iCG40	With 9 mm auxiliary			
Number of poles	Aux+N+1P	3 (Aux+N+1P)	Aux+N+1P+Vigi	3 (Aux+N+1P+Vigi)
Number of 18 mm modules	48	48	48	48
Catalogue numbers	A9XPA648	A9XPA748	A9XPV648	A9XPV748

Technical data		
Operating current at 40°C	(Ie)	80 A
Short circuit current	(Isc)	Compatible with the breaking capacity of Acti9 Schneider Electric circuit breakers
Rated insulation voltage	(Ui)	400 V AC (Ph/N) - 440 V AC (Ph/Ph)
Operating voltage	(Ue)	230 V AC (Ph/N) - 400 V AC (Ph/Ph)
Degree of protection		IP20
Pollution degree		3
Fire resistance IEC 60695-2-1		Self-extinguishing at 960°C 30 secondes
Color		RAL 9003

Complementary technical information

Horizontal comb busbars 9 mm modules for Acti9: iC40, iCV40, Vigi iC40 (cont.)

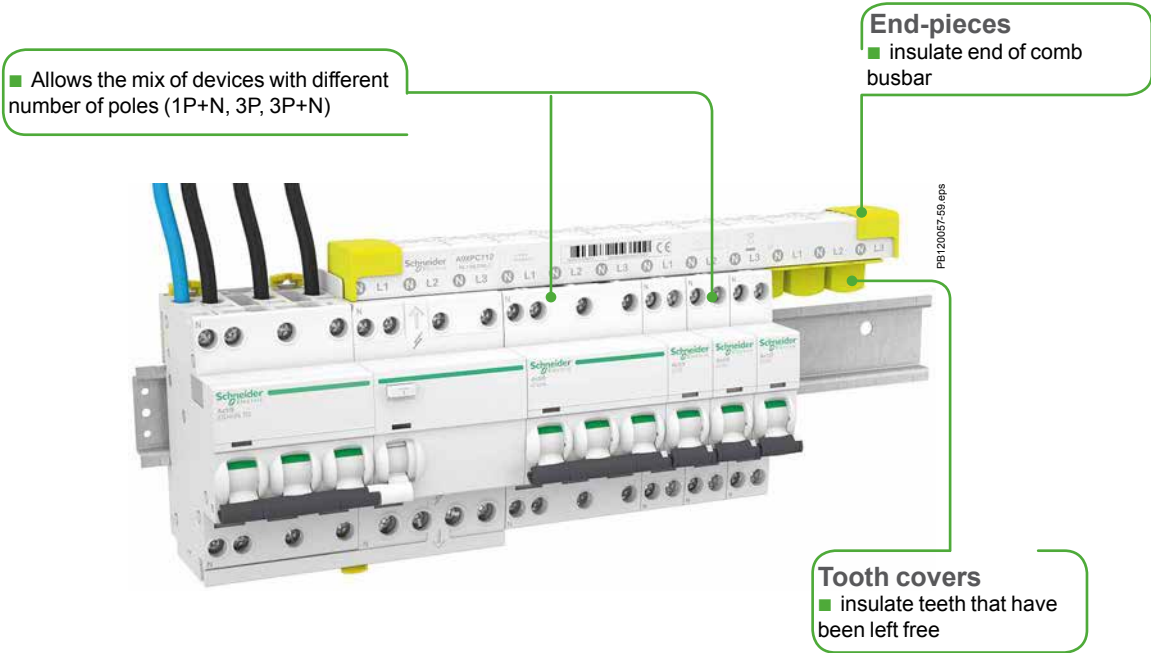

Accessories				
Number of poles	1P+N	3 (N+P)		
	End-pieces		Tooth covers (3 x 18 mm modules)	Connectors
Set of	40	40	12	4
Catalogue numbers	A9X21094	A9X21095	A9X21096	A9XPCM04

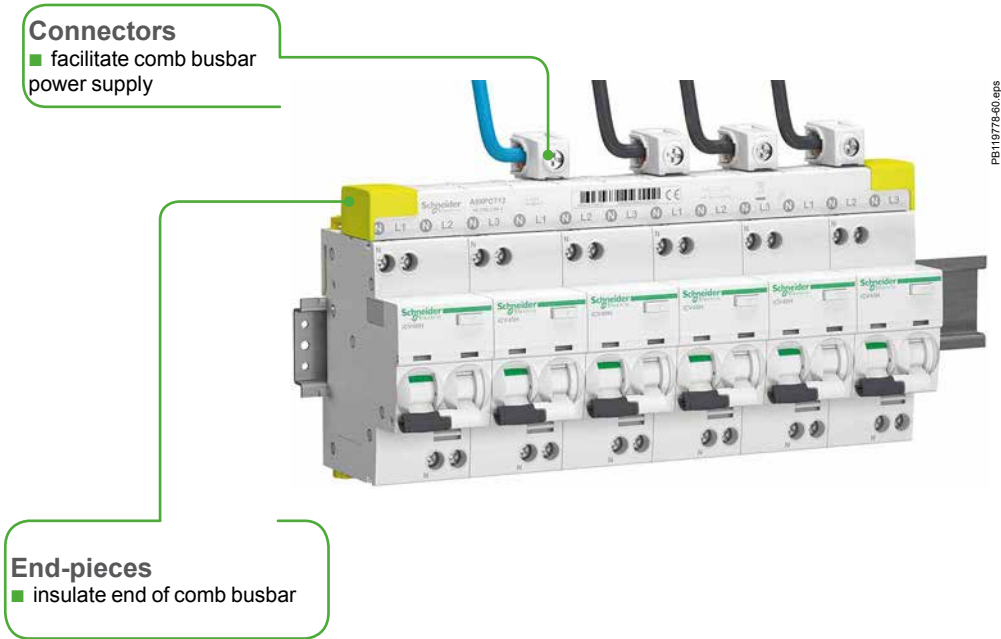

Horizontal comb busbars with integrated connectors, 9 mm modules for Acti9: iC40, iCV40



Acti9 iC40, iC40 XA, iCV40, iCV40 XA		9 mm poles, cuttable				
Number of poles	1P+N			3 (N+P)		
	 N L			 N L1 N L2 N L3		
Number of 18 mm modules	6	12	24	12	24	
Supplied accessories	Tooth covers (for 3 modules of 18 mm)					
	-	1	2	1	2	
	End-pieces					
	4	4	4	4	4	
Catalogue numbers	A9XPP606 (*)	A9XPP612 (*)	A9XPP624 (*)	A9XPP712	A9XPP724	

(*) **CAUTION**
INCOMPATIBILITY BETWEEN TWO-POLE COMB BUSBARS AND FOUR-POLE DEVICES
 - Never connect a two-pole comb busbar to a four-pole device, as this will result in a multi-phase bolted short circuit.
 - Always check that the head of group circuit breaker is in good working condition before connecting a comb busbar.
Failure to follow these instructions can result in injury or equipment damage.

Technical data		
Operating current at 40°C	(Ie)	63 A
Short circuit current	(Isc)	Compatible with the breaking capacity of Acti9 Schneider Electric circuit breakers
Rated insulation voltage	(Ui)	400 V AC (Ph/N) - 440 V AC (Ph/Ph)
Operating voltage	(Ue)	230 V AC (Ph/N) - 400 V AC (Ph/Ph)
Degree of protection		IP20
Pollution degree		3
Fire resistance IEC 60695-2-1		Self-extinguishing at 960°C 30 secondes
Color		RAL 9003

Complementary technical information

Horizontal comb busbars with integrated connectors, 9 mm modules for Acti9: iC40, iCV40 (cont.)

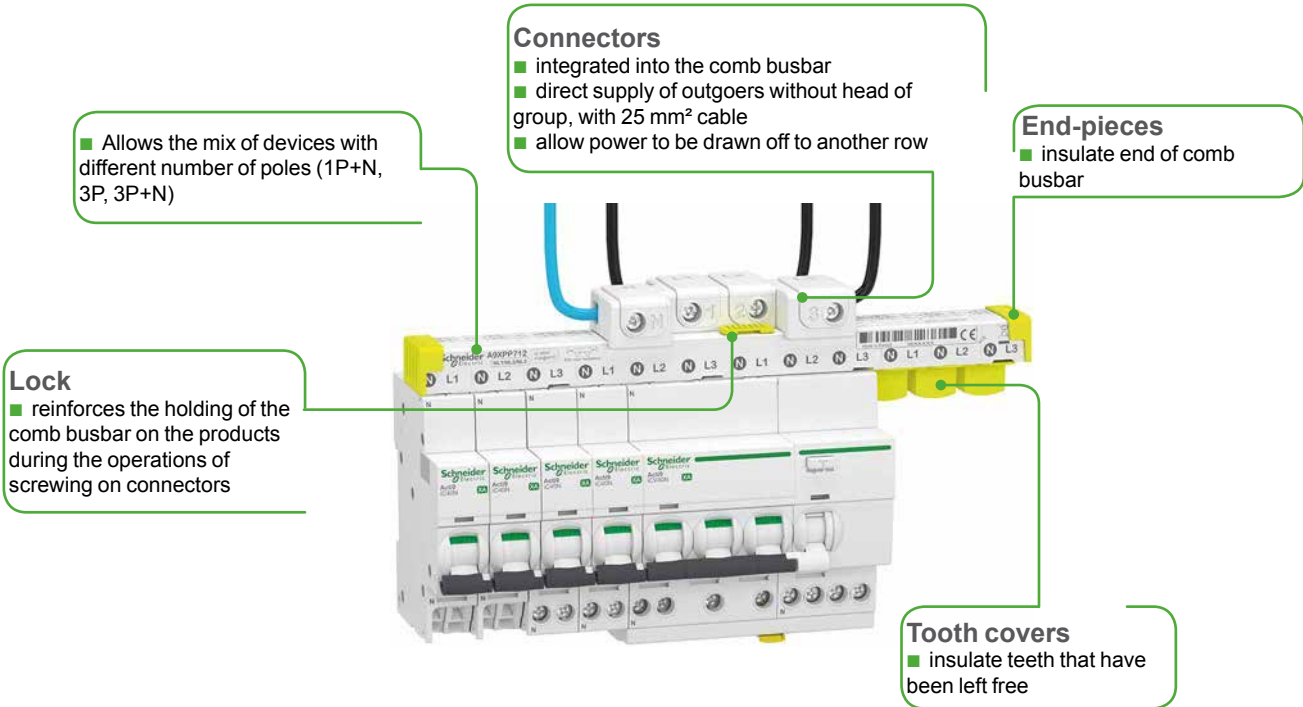

Accessories			
Number of poles	1P+N	3 (N+P)	
	End-pieces		Tooth covers (3 x 18 mm modules)
Set of	40	40	12
Catalogue numbers	A9X21094	A9X21095	A9X21096

Horizontal comb busbars 9 mm modules for Acti9: iCT

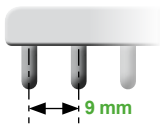

IEC 61439-1



Acti9 iCT		9 mm poles, cuttable	
Number of poles		Head of group 4P + 3 (N+P)	
Number of 18 mm modules		12	
Supplied accessories		1	
Tooth covers (for 3 modules of 18 mm)			
End-pieces		4	
Catalogue numbers		A9XCT712	

Technical data		
Operating current at 40°C	(Ie)	80 A
Short circuit current	(Isc)	Compatible with the breaking capacity of Acti9 Schneider Electric circuit breakers
Rated insulation voltage	(Ui)	400 V AC (Ph/N) - 440 V AC (Ph/Ph)
Operating voltage	(Ue)	230 V AC (Ph/N) - 400 V AC (Ph/Ph)
Degree of protection		IP20
Pollution degree		3
Fire resistance IEC 60695-2-1		Self-extinguishing at 960°C 30 secondes
Color		RAL 9003

Complementary technical information

Horizontal comb busbars 9 mm modules for Acti9: iCT (cont.)

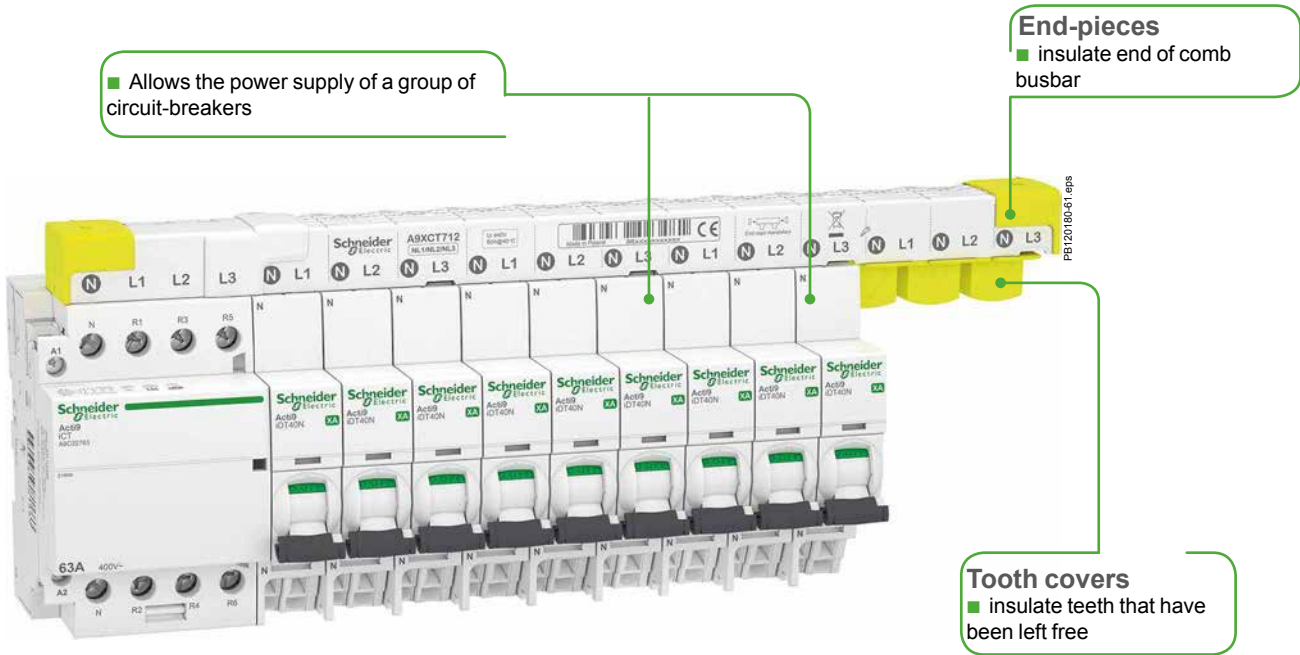

Accessories		
Number of poles	3 (N+P)	
		
	End-pieces	Tooth covers (3 x 18 mm modules)
Set of	40	12
Catalogue numbers	A9X21095	A9X21096



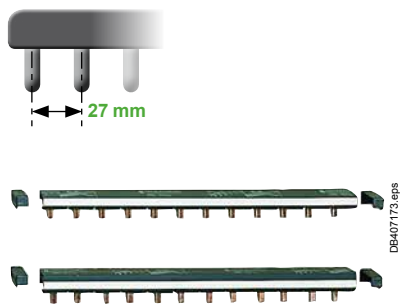

Complementary technical information

Horizontal comb busbars 27 mm modules for C120, NG125



IEC 60664-1



C120, NG125		27 mm poles, cuttable			
Number of poles	1P	2P	3P	4P	
	 L1	 L1 L2	 L1 L2 L3	 N L1 L2 L3	
Number of 27 mm modules	16	16	15	16	
Set of	1				
Catalogue numbers	14811	14812	14813	14814	

Technical data		
Operating current at 40°C (Ie)	125 A	
Short circuit current (Isc)	Compatible with the breaking capacity of Schneider Electric circuit breakers	
Rated insulation voltage (Ui)	620 V AC	
Operating voltage (Ue)	500 V AC	
Pollution degree	3	
Fire resistance IEC 60695-2-1	Self-extinguishing at 960°C 30 secondes	
Color	RAL 7016 (anthracite grey)	

Power supply
 ■ directly in the circuit breaker terminals



End-pieces
 ■ insulate end of comb busbar

Tooth covers
 ■ insulate teeth that have been left free

Accessories	
Number of poles	1P, 2P, 3P, 4P
	
	Tooth covers Insulate teeth that have been left free
Set of	20
Catalogue numbers	14818

Comb busbar assembly recommendation

Acti9

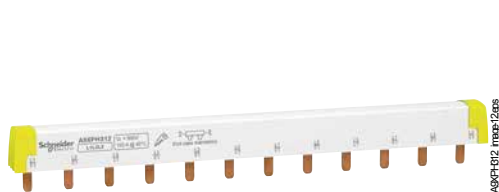

Cutting to length

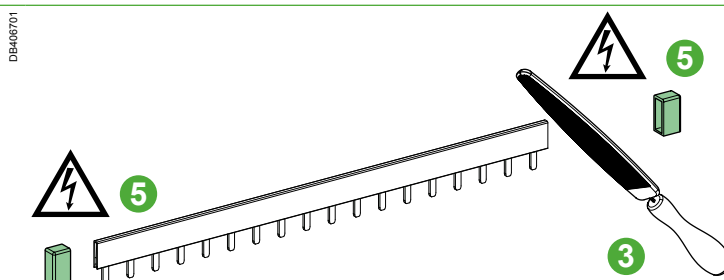
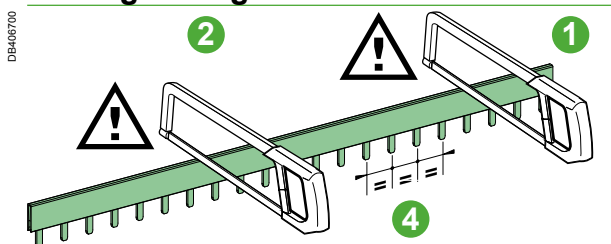

1- Cut perpendicularly (no angle > 10°) to the desired length using a circular miter saw for cutting metals.
 2- Maintain the direction of cutting from left to right.
 If this recommendation is not complied with, the copper busbar holding system is no longer active.

3- It is recommended to deburr after cutting.
 4- Check the regularity of the teeth spacing. Do not extract the copper terminals.
5- Mandatory end-pieces after cutting the comb busbar.

Direct power supply

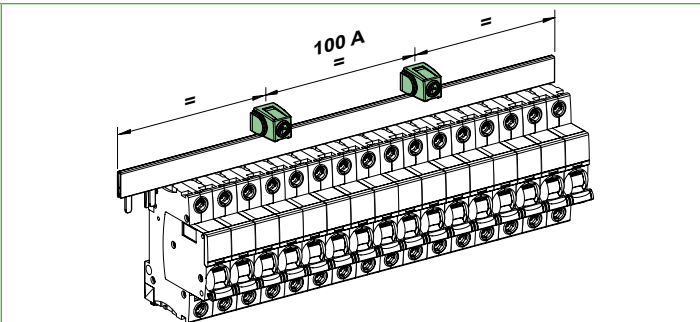
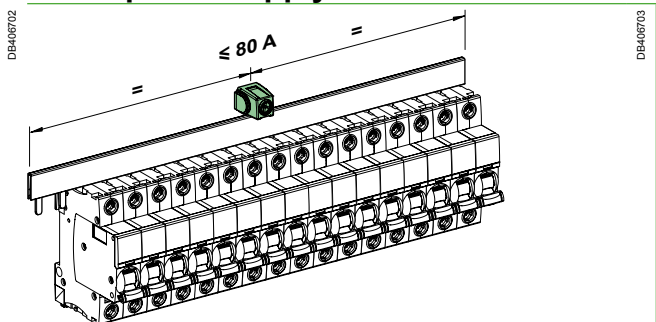

- Power supply ≤ 80 A by 1 connection point.
- Preferably choose the center of the comb busbar.

- 100 A power supply by 2 connection points mandatory.

Power supply by iID "group feeder" ≤ 80 A

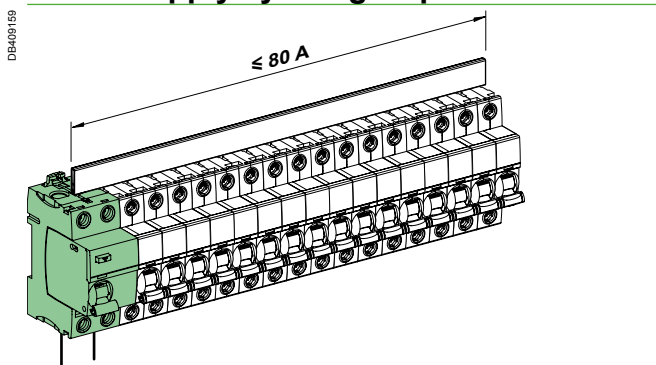

- RCCB "group feeder" ≤ 80 A: direct power supply by the RCCB.

Comb busbar assembly recommendation

Acti9 (cont.)

General

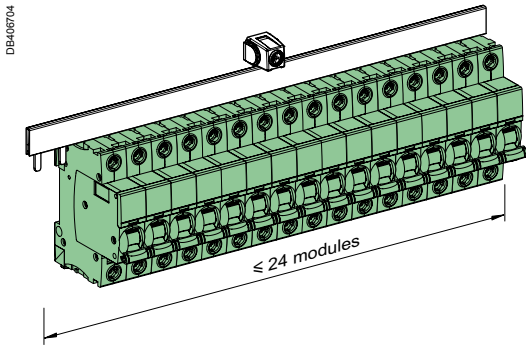

■ The quantity of products is not infinite, after 24 modules it is not possible to guarantee assembly.

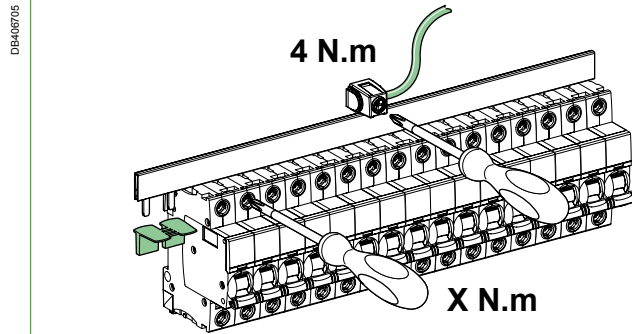

- Tightening to the recommended torque.
- Avoid tinning on the cable terminations, since tin has high resistivity.
- The comb teeth left unassigned should be isolated with tooth-cover end-pieces.

Plug-in base

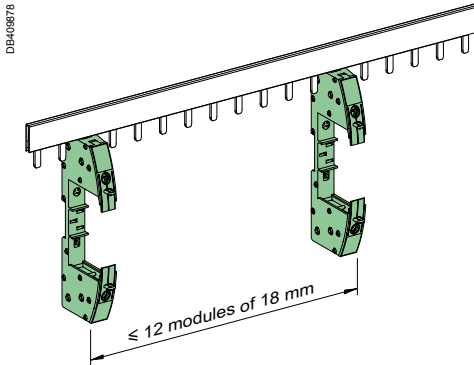

■ Special case: plug-in base (Cat. no. A9A27003), ≤ 12 x 18 mm modules.

Choice guide

Connection to the top
Circuit breakers iC60: 1P and 3P

Circuit breakers iC60 1P		
Type: L, ...	Number of 18 mm modules	Cat. no.
	6	A9XPH106
	12	A9XPH112
	24	A9XPH124
	57	A9XPH157

Circuit breakers iC60 1P or 3P (3 phases)		
Type: L1L2L3, ...	Number of 18 mm modules	Cat. no.
	6	A9XPH306
	9	A9XPH309
	12	A9XPH312
	16	A9XPH316
	18	A9XPH318
	24	A9XPH324
	57	A9XPH357



Circuit breakers iC60 1P + Auxiliaries 9 mm		
Type: L, ...	Number of 18 mm modules	Cat. no.
	57	A9XAH157

Circuit breakers iC60 1P + Auxiliaries 9 mm		
Type: AuxL1AuxL2AuxL3, ...	Number of 18 mm modules	Cat. no.
	57	A9XAH657

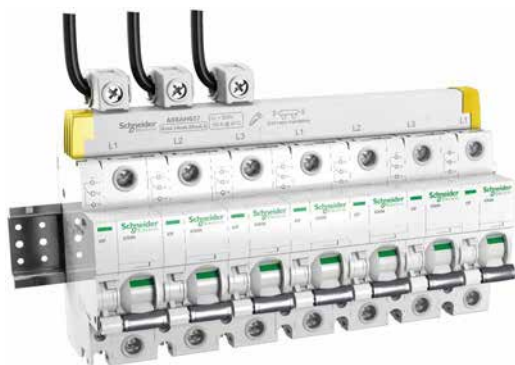

Complementary technical information

Choice guide

Connection to the top Circuit breakers iC60: 1P and 3P (cont.)

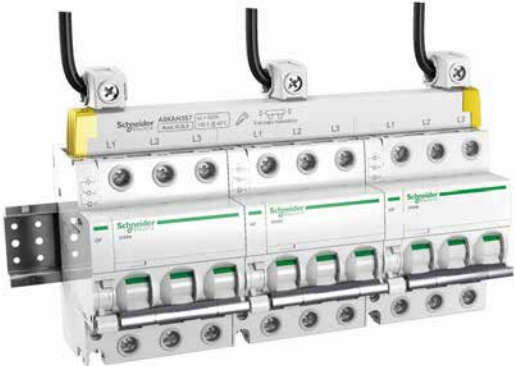

Circuit breakers iC60 3P with Auxiliaries 9 mm			
Type: AuxL1L2L3, ...	Number of 18 mm modules	Cat. no.	
	57	A9XAH357	

Choice guide

Connection to the top

Circuit breakers iC60: 1P+N, 2P and 4P

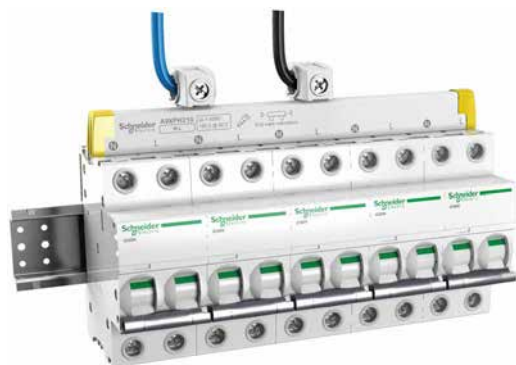

PB117804-47.eps

(*) **CAUTION**
INCOMPATIBILITY BETWEEN 1P+N COMB BUSBARS AND 3P+N DEVICES
 - Never connect a 1P+N comb busbar to a 3P+N device, as this will result in a multi-phase bolted short circuit.
 - Always check that the head of group circuit breaker is in good working condition before connecting a comb busbar.
Failure to follow these instructions can result in injury or equipment damage.

Circuit breakers 1P+N, 2P

Type: NL, ...	Number of 18 mm modules	Cat. no.
	6	A9XPH206 (*)
	8	A9XPH208 (*)
	10	A9XPH210 (*)
	12	A9XPH212 (*)
	18	A9XPH218 (*)
	24	A9XPH224 (*)
	57	A9XPH257 (*)

Circuit breakers 1P+N (Neutral + 3 phases)

Type: NL1NL2NL3, ...	Number of 18 mm modules	Cat. no.
	12	A9XPH512
	18	A9XPH518
	24	A9XPH524
	57	A9XPH557



PB117805-48.eps



Montage ATHENA 01.jpg

RCCB 3P+N + circuit breakers iC60 1P+N

Type: NL1L2L3NL1NL2NL3, ...	Number of 18 mm modules	Cat. no.
	10	A9XPH810
	12	A9XPH812
	14	A9XPH814
	16	A9XPH816

Circuit breakers 2P + Auxiliaries 9 mm (Aux + Neutral + Phase)

Type: AuxL1L2, ...	Number of 18 mm modules	Cat. no.
	57	A9XAH257



PB117821-37.eps

Choice guide

Connection to the top

Circuit breakers iC60: 1P+N, 2P and 4P (cont.)

Circuit breakers 1P+N + Auxiliaries 9 mm (Aux + Neutral + 3 phases)

Type: AuxNL1AuxNL2AuxNL3, ...	Number of 18 mm modules	Cat. no.
	57	A9XAH557

Circuit breakers 1P+N + Vigi iC60 25 A

Type: NL1NL2NL3, ...	Number of 18 mm modules	Cat. no.
	21	A9XPF521



PB117806-27.eps

Circuit breakers 1P+N + Vigi iC60 40 or 63 A

Type: NL1NL2NL3, ...	Number of 18 mm modules	Cat. no.
	24	A9XPF524



PB117807-30.eps

Circuit breakers 1P+N + Vigi iC60 25 A + Auxiliaries 9 mm

Type: AuxNL1AuxNL2AuxNL3, ...	Number of 18 mm modules	Cat. no.
	24	A9XPF524



PB117808-29.eps

Choice guide

Connection to the top

Circuit breakers iC60: 1P+N, 2P and 4P (cont.)



Circuit breakers 3P+N			
Type: NL1L2L3, ...		Number of 18 mm modules	Cat. no.
		8	A9XPH408
		12	A9XPH412
		16	A9XPH416
		24	A9XPH424
		57	A9XPH457

Circuit breakers 3P+N + Auxiliaries 9 mm			
Type: AuxNL1L2L3, ...		Number of 18 mm modules	Cat. no.
		57	A9XAH457

Circuit breakers 3P+N + Vigti iC60 25 A (3 modules) + 2 spacers			
Type: NL1L2L3, ...		Number of 18 mm modules	Cat. no.
		12	A9XPH412
		24	A9XPH424
		57	A9XPH457

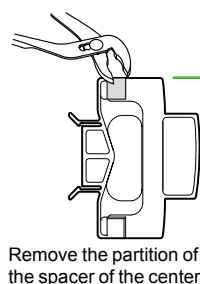

Circuit breakers 3P+N + Vigti iC60 40 or 63 A (3.5 modules) + 1 spacer			
Type: NL1L2L3, ...		Number of 18 mm modules	Cat. no.
		12	A9XPH412
		24	A9XPH424
		57	A9XPH457

Choice guide

Connection to the top - Circuit breakers

Acti9 iC40, iCV40, Vigi iC40

(*) **CAUTION**
INCOMPATIBILITY BETWEEN 1P+N COMB BUSBARS AND 3P+N DEVICES
 - Never connect a 1P+N comb busbar to a 3P+N device, as this will result in a multi-phase bolted short circuit.
 - Always check that the head of group circuit breaker is in good working condition before connecting a comb busbar.
Failure to follow these instructions can result in injury or equipment damage.

Circuit breakers iC40, iC40 XA, iDPN 1P+N		
Type: NL, ...	No. of 18 mm modules	Cat. no.
	12	A9XPC612 (*)
	24	A9XPC624 (*)
	48	A9XPC648 (*)

Circuit breakers iCV40, iCV40 XA, iDPN Vigi, Vigi iC40, Vigi iCG40 1P+N		
Type: NL, ...	No. of 18 mm modules	Cat. no.
	12	A9XPC612 (*)
	24	A9XPC624 (*)
	48	A9XPC648 (*)

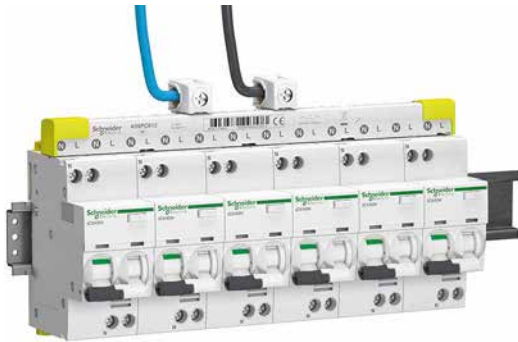

Circuit breakers iC40, iC40 XA, iDPN 1P+N with comb busbar 3P+N		
Type: NL1L2L3, ...	No. of 18 mm modules	Cat. no.
	12	A9XPC712
	24	A9XPC724
	48	A9XPC748

Circuit breakers iCV40, iCV40 XA, iDPN Vigi, Vigi iC40, Vigi iCG40 1P+N with comb busbar 3P+N		
Type: NL1L2L3, ...	No. of 18 mm modules	Cat. no.
	12	A9XPC712
	24	A9XPC724
	48	A9XPC748

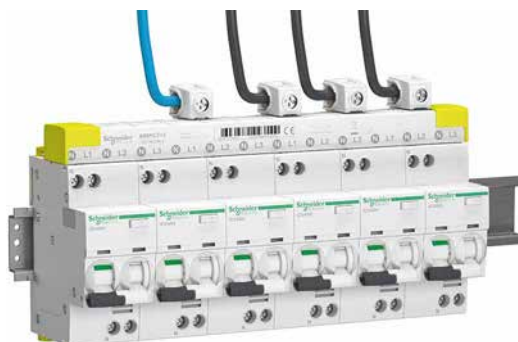

Choice guide

Connection to the top - Circuit breakers

Acti9 iC40, iCV40

(*) **CAUTION**

INCOMPATIBILITY BETWEEN 1P+N COMB BUSBARS AND 3P+N DEVICES

- Never connect a 1P+N comb busbar to a 3P+N device, as this will result in a multi-phase bolted short circuit.
- Always check that the head of group circuit breaker is in good working condition before connecting a comb busbar.

Failure to follow these instructions can result in injury or equipment damage.

Circuit breakers iC40, iC40 XA, iDPN 1P+N		
Type: NL, ... with integrated connectors	No. of 18 mm modules	Cat. no.
	6	A9XPP606 (*)
	12	A9XPP612 (*)
	24	A9XPP624 (*)

Circuit breakers iCV40, iCV40 XA, iDPN Vigi, Vigi iC40, Vigi iCG40 1P+N		
Type: NL, ... with integrated connectors	No. of 18 mm modules	Cat. no.
	6	A9XPP606 (*)
	12	A9XPP612 (*)
	24	A9XPP624 (*)

Circuit breakers iC40, iC40 XA, iDPN 1P+N with comb busbar 3P+N		
Type: NL1L2L3, ... with integrated connectors	No. of 18 mm modules	Cat. no.
	12	A9XPP712
	24	A9XPP724

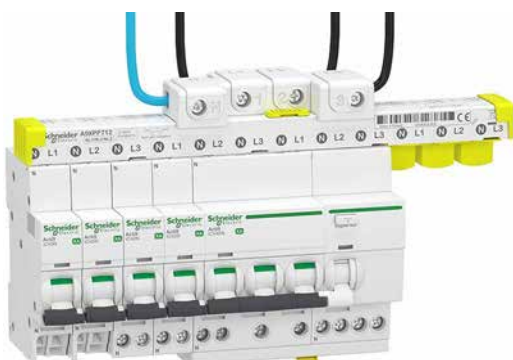

PB120220-53.eps

Circuit breakers iCV40, iCV40 XA, iDPN Vigi, Vigi iC40, Vigi iCG40 1P+N with comb busbar 3P+N		
Type: NL1L2L3, ... with integrated connectors	No. of 18 mm modules	Cat. no.
	12	A9XPP712
	24	A9XPP724

Choice guide

Connection to the top - Circuit breakers

Acti9 iC40, iCV40, Vigi iC40 (cont.)



Circuit breakers iC40, iC40 XA, iDPN 1P+N + Auxiliaries 9 mm		
Type: AuxNL, ...	No. of 18 mm modules	Cat. no.
	48	A9XPA648

Circuit breakers iC40, iC40 XA, iDPN 1P+N with comb busbar 3P+N + Auxiliaries 9 mm		
Type: AuxNL1AuxNL2AuxNL3, ...	No. of 18 mm modules	Cat. no.
	48	A9XPA748

Circuit breakers iCV40, iCV40 XA, (iC40+Vigi), (iC40 XA+Vigi), (iDPN+Vigi), Vigi iC40, Vigi iCG40 1P+N + Auxiliaries 9 mm		
Type: AuxNL, ...	No. of 18 mm modules	Cat. no.
	48	A9XPV648

Circuit breakers iCV40, iCV40 XA, (iC40+Vigi), (iC40 XA+Vigi), (iDPN+Vigi), Vigi iC40, Vigi iCG40 1P+N with comb busbar 3P+N + Auxiliaries 9 mm		
Type: AuxNL1AuxNL2AuxNL3, ...	No. of 18 mm modules	Cat. no.
	48	A9XPV748

Choice guide

Connection to the top

Circuit breakers C120 and NG125

Circuit breakers C120 or NG125 1P		
Type: L, ...	Number of 27 mm modules	Cat. no.
	16	14811

Circuit breakers C120 or NG125 2P		
Type: L1L2, ...	Number of 27 mm modules	Cat. no.
	16	14812

Circuit breakers C120 or NG125 3P		
Type: L1L2L3, ...	Number of 27 mm modules	Cat. no.
	15	14813



Circuit breakers C120 or NG125 4P		
Type: NL1L2L3, ...	Number of 27 mm modules	Cat. no.
	16	14814

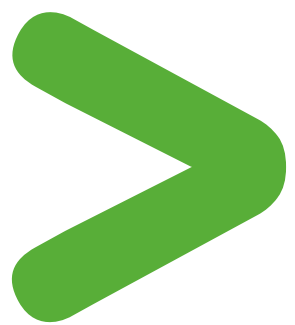

Biconnect horizontal comb busbars 18 mm modules

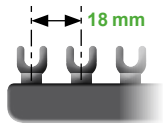

IEC 60664-1



Acti9 K60 biconnect	18 mm poles, cuttable					
Number of poles	1P			2P		
Type	L1,...			L1L2,...		
Set of	1			1		
Number of 18 mm modules	12	18	57	12	18	57
Catalogue numbers	R9XFH112	R9XFH118	R9XFH157	R9XFH212	R9XFH218	R9XFH257



Technical data	
Operating current at 40°C (Ie)	63 A
Cross section	10 mm ²
Short circuit current (Isc)	Compatible with the breaking capacity of Schneider Electric circuit breakers
Rated insulation voltage (Ui)	500 V AC
Operating voltage (Ue) L/N	230 V AC
	L/L
	400 V AC
Pollution degree	3
Fire resistance IEC 695-2-1	Self-extinguishing at 960°C 30 secondes
Color	RAL 9003

End-pieces
 ■ essential to ensure the correctly comb busbars insulation





Tooth covers
 ■ Insulate teeth that have been left free

Biconnect horizontal comb busbars 18 mm modules (cont.)

3P						4P			Head of group + 3 (N+P)	3 (N+P)															
L1 L2 L3 						N L1 L2 L3 				N L1 N L2 N L3 															
L1L2L3,...						NL1L2L3,...			NL1L2L3 / NL1NL2NL3,...	NL1NL2NL3,...															
1						1			1	1															
6		9		11		12		18		57		12		18		57									
R9XFH306		R9XFH309		R9XFH311		R9XFH312		R9XFH318		R9XFH357		R9XFH412		R9XFH418		R9XFH457		R9XFH518G		R9XFH512		R9XFH518		R9XFH557	

Accessories

Number of poles	1P	2P	3P	4P	
		 R9XE210-20 apps			 R9XT20-20 apps
	End-pieces				Tooth covers
Set of	10				20
Catalogue numbers	R9XE110	R9XE210	R9XE310	R9XE410	R9XT20

Complementary technical information

Horizontal comb busbars 18 mm modules for Acti9: iC60



Acti9 iC60	18 mm poles, cuttable				
Number of poles	1P	1 (N+P)	3P	4P	3 (N+P)
	L1	N L1	L1 L2 L3	N L1 L2 L3	N L1 N L2 N L3
Type	L1,...	NL1,...	L1L2L3,...	NL1L2L3,...	NL1NL2NL3,...
Set of	1	1	1	1	1
Catalogue numbers					
6 modules of 18 mm	A9XPH106	A9XPH206	A9XPH306	-	-
8 modules of 18 mm	-	A9XPH208	-	A9XPH408	-
9 modules of 18 mm	-	-	A9XPH309	-	-
10 modules of 18 mm	-	A9XPH210	-	-	-
11 modules of 18 mm	-	-	A9XPH311	-	-
12 modules of 18 mm	A9XPH112	A9XPH212	A9XPH312	A9XPH412	A9XPH512
16 modules of 18 mm	-	-	A9XPH316	A9XPH416	-
18 modules of 18 mm	-	A9XPH218	A9XPH318	-	A9XPH518
20 modules of 18 mm	-	-	A9XPH320	-	-
24 modules of 18 mm	A9XPH124	A9XPH224	A9XPH324	A9XPH424	A9XPH524
57 modules of 18 mm	A9XPH157	A9XPH257	A9XPH357	A9XPH457	A9XPH557

Technical data

Operating current at 40°C (Ie)	100 A
Cross section	16 mm ²
Short circuit current (Isc)	Compatible with the breaking capacity of Schneider Electric circuit breakers
Rated insulation voltage (Ui)	500 V AC
Operating voltage (Ue)	415 V AC
Pollution degree	3
Fire resistance IEC 695-2-1	Self-extinguishing at 960°C 30 secondes
Color	RAL 9003

End-pieces
 ■ essential to ensure the correctly comb busbars insulation



Tooth covers
 ■ Insulate teeth that have been left free

Accessories

Number of poles	1P Aux+1P	2P Aux+2P	3P Aux+3P 3 (Aux+1P)	4P Aux+4P 3 (Aux+N+1P)		
	End-pieces				Tooth covers	
	Lateral end-pieces providing IP20 protection				Insulate teeth that have been left free	
					Connectors	
					Double terminal	
					Comb busbar power supply. Horizontal in-comer on each side. For 35 mm ² cable. Tightening torque 4 N.m	
Set of	10	10	10	10	20	4
Catalogue numbers	A9XPE110	A9XPE210	A9XPE310	A9XPE410	A9XPT920	A9XPCD04

Horizontal comb busbars 18 mm modules for Acti9: iC60 (cont.)



Cuttable comb busbars, 18 mm modules, with 9 mm auxiliary					
Aux+1P	Aux+2P	Aux+3P	Aux+4P	3 (Aux+1P)	3 (Aux+N+1P)
AuxL1,...	AuxL1L2,...	AuxL1L2L3,...	AuxNL1L2L3,...	AuxL1AuxL2AuxL3,...	AuxNL1AuxNL2AuxNL3,...
1	1	1	1	1	1
-	-	-	-	-	-
-	-	-	-	-	-
-	-	-	-	-	-
-	-	-	-	-	-
-	-	-	-	-	-
-	-	-	-	-	-
-	-	-	-	-	-
-	-	-	-	-	-
-	-	-	-	-	-
A9XAH157	A9XAH257	A9XAH357	A9XAH457	A9XAH657	A9XAH557

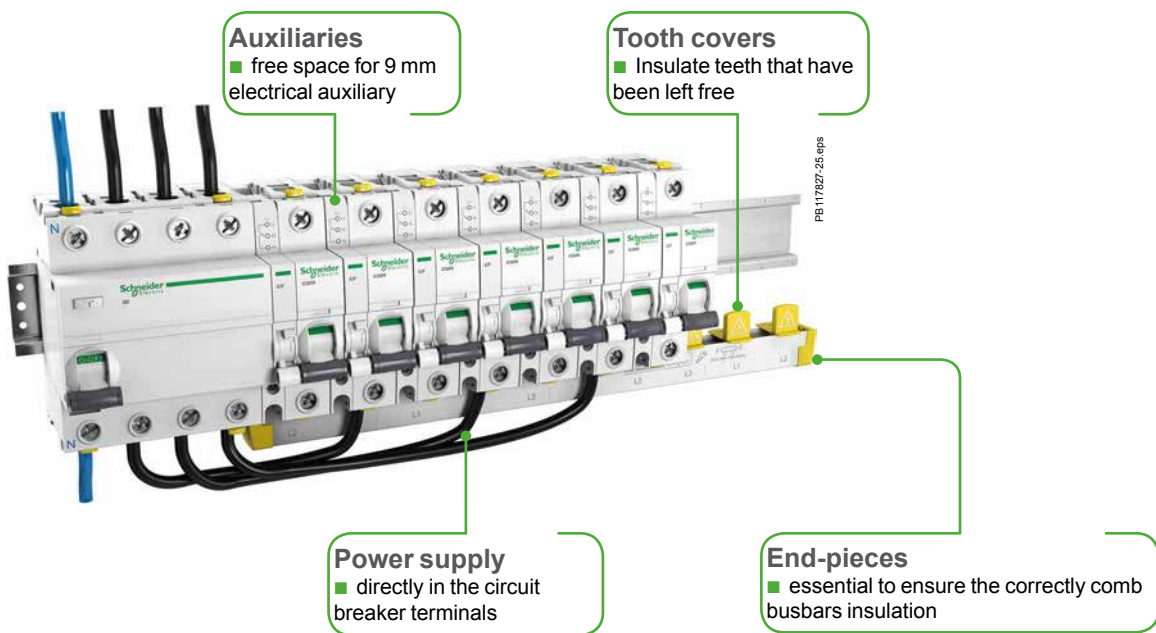

Complementary technical information

Horizontal comb busbars 18 mm modules for Acti9: iLD

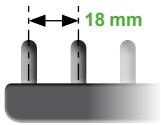

IEC 60947-7-1, IEC 61439-1



Acti9 iLD		18 mm poles, iLD 4P / iC60 1P+N				
Number of poles	Head of group + 3 (N+P)					
Type	NL1L2L3 / NL1NL2NL3,...					
Set of	1					
Number of 18 mm modules	10	12	14	16	22	
Cat. no.	A9XPH810	A9XPH812	A9XPH814	A9XPH816	A9XPH822	

Technical data		
Operating current at 40°C	(Ie)	80 A
Cross section		16 mm ²
Short circuit current	(Isc)	Compatible with the breaking capacity of Schneider Electric circuit breakers
Rated insulation voltage	(Ui)	500 V AC
Operating voltage	(Ue)	230 V AC (Ph/N) / 400 V AC (Ph/Ph)
Rated impulse withstand voltage	(Uimp)	6 kV
Degree of protection IEC 60529		IP20
Pollution degree		3
Fire resistance IEC 695-2-1		Self-extinguishing at 960°C 30 secondes
Colour		RAL 9003

End-pieces
 ■ essential to ensure the correctly comb busbars insulation



PB117829-24.eps

Accessories		
	End-pieces	Tooth covers
Use	Lateral end-pieces providing IP20 protection mounted on each side of the comb busbar	Insulate teeth that have been left free
Set of	10	20
Cat. no.	A9XPE410	A9XPT920

Complementary technical information

Horizontal comb busbars 27 mm modules for C120, NG125

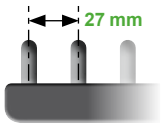

IEC 60664-1



C120, NG125		27 mm poles, cuttable			
Number of poles	1P	2P	3P	4P	
	L1	L1 L2	L1 L2 L3	N L1 L2 L3	
Type	L1,...	L1L2,...	L1L2L3,...	NL1L2L3,...	
Set of	1				
Number of 27 mm modules	16	16	15	16	
Catalogue numbers	14811	14812	14813	14814	

Technical data	
Operating current at 40°C (Ie)	125 A
Short circuit current (Isc)	Compatible with the breaking capacity of Schneider Electric circuit breakers
Rated insulation voltage (Ui)	620 V AC
Operating voltage (Ue)	500 V AC
Degree of protection	3
Fire resistance IEC 695-2-1	Self-extinguishing at 960°C 30 secondes
Color	RAL 7016 (anthracite grey)



End-pieces
 ■ essential to ensure the correctly comb busbars insulation

Power supply
 ■ directly in the circuit breaker terminals

Tooth covers
 ■ Insulate teeth that have been left free

Accessories	
Number of poles	1P, 2P, 3P, 4P
	Tooth covers Insulate teeth that have been left free
Set of	20
Catalogue numbers	14818

IEC 60947-7-1, IEC 61439-2



Description

- Downstream circuits are connected from the front, to spring terminals.
- Contact pressure automatically adapts to the size of the conductor.
- Contacts are insensitive to vibrations and thermal variations.
- Only one cable (flexible or rigid) can be inserted per terminal.

Quick distribution blocks



Number of poles		4P, incomers from top	4P, incomers from bottom
Rated operational current at 40 °C (Ie)		63 A	63 A
Rated conditional short-circuit current of an assembly (Isc)		The reinforced breaking capacity due to cascading in circuit breaker combinations is maintained. The worst-case situations have been tested.	The reinforced breaking capacity due to cascading in circuit breaker combinations is maintained. The worst-case situations have been tested.
Rated insulation voltage (Ui)		500 V AC	500 V AC
Rated operational voltage (Ue)		440 V AC	440 V AC
Rated impulse withstand voltage (Uimp)		6 kV	6 kV
Rated short-time withstand current (Icw)		-	-
Rated operational frequency		50/60 Hz	50/60 Hz
Degree of protection		IPxxB	IPxxB
Incoming terminals		1 tunnel terminal 25 ² /phase	1 tunnel terminal 25 ² /phase
Total connection capacity, outgoing terminals		24 connections: 4 x 6 ² /phase 12 x 6 ² /neutral	24 connections: 4 x 6 ² /phase 12 x 6 ² /neutral
Dimensions (H x W x D)		96.5 x 72 x 62 8 x 9 mm pitch	96.5 x 72 x 62 8 x 9 mm pitch
Installation		Clipped onto a DIN rail	Clipped onto a DIN rail
Other			
Standard for installation inside Prisma		IEC 61439-2	IEC 61439-2
Glow-wire 60695-2-11		960 °C	960 °C
Degree of pollution		3	3
References		04040	04041

Accessories

References	-	-
-------------------	---	---

Advantages

- A reliable electrical connection, no maintenance required (tightness guaranteed over time).
- Quick connection.
- Easy phase balancing.
- Ease of rewiring if the switchboard is expanded or modified.

4P		1P	
			
125 A	160 A	160 A	
20 kA/60 ms max according to IEC 61439-1	20 kA/60 ms max according to IEC 61439-1	32 kA	
750 V AC	750 V AC	750 V AC	
690 V AC	690 V AC	690 V AC	
8 kV	8 kV	8 kV	
4.5 kA rms/1 s	4.5 kA rms/1 s		
50/60 Hz	50/60 Hz	50/60 Hz	
IPxxB	IPxxB	IPxxB	
1 tunnel terminal 35 ² /phase	1 tunnel terminal 35 ² /phase	1 tunnel terminal 70 ² /phase	
52 connections: 7 x 4 ² /phase 3 x 6 ² /phase 2 x 10 ² /phase 1 x 16 ² /phase (screw terminal)	52 connections: 7 x 4 ² /phase 3 x 6 ² /phase 2 x 10 ² /phase 1 x 16 ² /phase (screw terminal)	6 connections: 6 x 16 ² /phase	
127 x 108 x 48 8 x 9 mm pitch	127 x 108 x 48 8 x 9 mm pitch	95 x 36 x 70 4 x 9 mm pitch	
Screwed to plain or slotted backplate or onto DIN rail	Screwed to plain or slotted backplate or onto DIN rail	Onto DIN rail	
Possible to combine 2 terminal blocks (2 nd terminal block supplied from enclosed terminals in the 1 st , I _{max} of 2 nd terminal block: 80 A)	Possible to combine 2 terminal blocks (2 nd terminal block supplied from enclosed terminals in the 1 st , I _{max} of 2 nd terminal block: 80 A)		
IEC 61439-2	IEC 61439-2	IEC 61439-2	
960 °C	960 °C	960 °C	
3	3	3	
04045	04046	04031	

125 A flexible connectors (4)		Copper spacer (batch of 4)
04047	-	04037

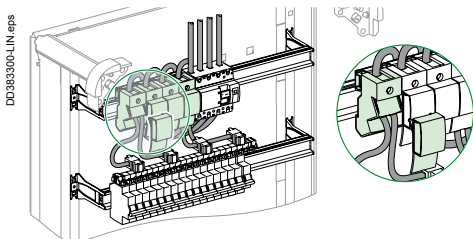
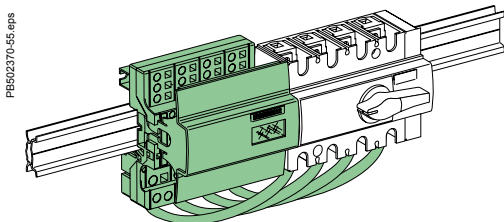

IEC 60947-7-1, IEC 61439-2



Description

- Distribution over full rows of modular devices.
- The distribution block is generally supplied by busbars in enclosures and cubicles.
- Easy phase balancing.
- Mix of devices and functions in the same row.
- Installation ≥ 160 A: clipped onto the back of a modular rail or screwed onto a solid or pre-slotted plate.

Distribution blocks

Number of poles		4P	4P	
		63 A	80 A	
Rated peak withstand current (Ipk)		15 kA	15 kA	
Rated conditional short-circuit current of an assembly (Isc)		The cascading reinforced breaking capacity when combining circuit breakers is maintained. The worst-case scenarios have been tested. The characteristics are exactly right for the connected devices. Circuit breakers and switches still have their temperature derating curves, and their whole performance is maintained.		
Rated insulation voltage (Ui)		500 V AC	500 V AC	
Rated operational voltage (Ue)		440 V AC	440 V AC	
Rated impulse withstand voltage (Uimp)		6 kV	6 kV	
Maximum current (Imax)		-	-	
Rated operational frequency		50/60 Hz		
Degree of protection		IPxxB		
Lenght	In 9 mm modules	24	48	
	In 18 mm modules	12	24	
Upstream connection capacity		Tunnel terminals for cables up to 25 mm ²		
Downstream connection capacity, cable to be used without ferrules	Max. 4 mm ²	Phase	2	7
		Neutral	4	13
	Max. 6 mm ²	Phase	2	2
		Neutral	4	4
Max. 10 mm ²	Phasesw	-	-	
	Neutral	-	-	
Accessories included	Pre-stripped copper connections	10 of 4 mm ² + 6 of 6 mm ² (L = 100 mm)		
	Protective cover			
	Screws and nuts			
References		04008	04004	

Installation

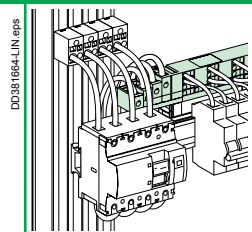

Clipped onto the back of a modular rail, or screw fixing

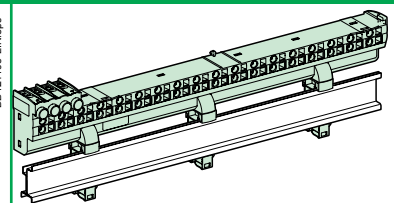



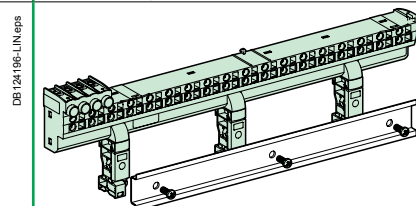

Clipped onto the back of a modular rail, or screw fixing

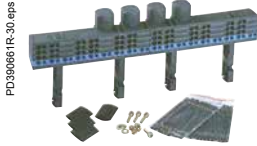



Can be mounted in Pragma Evolution enclosures and in Prisma Pack 160

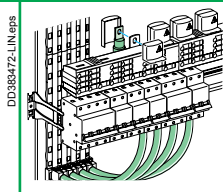
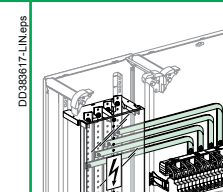
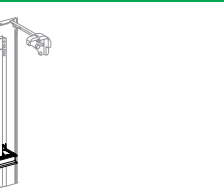

4P	2P	3P	4P	4P
				
160 A 27 kÅ	200 A 25 kÅ	200 A 25 kÅ	200 A 30 kÅ	200 A 27 kÅ
The cascading reinforced breaking capacity when combining circuit breakers is maintained. The worst-case scenarios have been tested.				
750 V AC	750 V AC	750 V AC	750 V AC	750 V AC
690 V AC	690 V AC	690 V AC	690 V AC	690 V AC
8 kV	8 kV	8 kV	8 kV	8 kV
50 A for feeder for 10 mm ² cable/63 A for feeder for 2 cables of 10 mm ²				
50/60 Hz				
IPxxB				
24	48			72
12	24			36
Direct on directing pads by 50 mm ² cables or by 20 x 3 flexible bar with a prefabricated connection from busbar				
-	-			
-	-			
6	12			
6	18			
20 of 4 mm ² + 6 of 6 mm ² (L = 100 mm)				
For pads (IPxxB)				
For pads				
04018	04012	04013	04014	04026

Connections to the distribution block

				
4P 200 A connection (supplied with fixing accessories)	4P 200 A connection (supplied with fixing accessories)	4P 200 A connection (supplied with fixing accessories)	4P 160 A connection for Linergy FM 1/2 row	
Allows power supply from	Linergy BW busbar	Linergy BS sheathed busbar	Linergy BS rear busbar	Switchgear
References	04021	04024	04029	04030

Spare parts

	
4 covers for 160/200 A Linergy FM rows	
Reference	01202

Linergy DS

Screw distribution blocks



IEC/EN 60947-7-1, IEC/EN 61439-1 & 2

Description

- Single-pole or four-pole distribution block that can be installed on a standard DIN rail or on a mounting plate.
- Compatible with Prisma G and P, Pragma, Mini Pragma and Resbo series switchboards.
- Incomers and feeders are connected to screw terminals that accept rigid or flexible cables with ferrule.
- Optional: additional neutral terminal strip for four-pole distribution block.

Advantages

- Simplified power supply for main incomers.
- Easy phase balancing.
- Easy, effortless cabling due to excellent accessibility.
- Visible cabling.
- Insulation between phases.
- The single-pole distribution blocks are adjacent and bridgeable via the second incoming hole for parallel connection.

Screw distribution blocks

Number of poles	1P			4P
				
Rated operational current	125 A	160 A	250 A	100 A
Total connections capacity	10	13	14	4 x 7
Terminal capacity				
Diameter	2 x Ø 9.5 mm	2 x Ø 12 mm	1 x Ø 15.3 mm	2 x Ø 7.5 mm
	2 x Ø 7.5 mm	3 x Ø 7.5 mm	1 x Ø 10 mm	5 x Ø 5.5 mm
	6 x Ø 5.8 mm	8 x Ø 5.8 mm	4 x Ø 6 mm	-
	-	-	8 x Ø 7.5 mm	-
Rated peak withstand current (I _{pk} /60 ms)	25 kÅ	36 kÅ	60 kÅ	14 kÅ
	(I _{pk} /6 ms)	-	-	24 kÅ
Rated short-time withstand current (I _{cs}) (IEC/EN 60947-7-1)	4.2 kA rms/1 s	8.4 kA rms/1 s	14.4 kA rms/1 s	3 kA rms/1 s
Width (number of 9 mm pitches)	3	4	5	8
Dimension (H x W x D)	85 x 27 x 50.5	85 x 36 x 50.5	85 x 45 x 50.5	100 x 71 x 50.5
Weight (g)	125	163	239	210
Neutral terminal strip (optional)	-	-	-	LGYN1007
References	LGY112510	LGY116013	LGY125014	LGY410028

Linergy distribution systems

Distribution blocks

Linergy DS

Screw distribution blocks

DB40805_1.eps



On LGY412560 and LGY416048 references.
Input cabling facilitated by side terminals.

Technical data

Common characteristics

To IEC/EN 60947-7-1 and IEC/EN 61439-1 & 2

Rated insulation voltage (Ui)	500 V AC
Rated operational voltage (Ue)	230 V AC (Ph/N) 440 V AC (Ph/Ph)
Rated impulse withstand voltage (Uimp)	8 kV
Rated conditional short-circuit current of an assembly	Up to the breaking capacity of Schneider Electric feeder circuit breakers, even in cascading configuration
Network frequency	50/60 Hz
Pollution degree	3
Overvoltage category	III

Additional technical characteristics

Reference temperature	40 °C
Operating temperature	-25 °C to 55 °C
Dielectric withstand (IEC/EN 60947-1)	2500 V AC

			Neutral terminal strip			
125 A		160 A	100 A	125 A		
4 x 12	4 x 15	4 x 12	7	12		15
1 x Ø 9 mm	1 x Ø 9.5 mm	1 x Ø 12 mm	2 x Ø 7.5 mm	1 x Ø 9 mm		1 x Ø 9.5 mm
7 x Ø 7.5 mm	3 x Ø 8.5 mm	3 x Ø 9 mm	5 x Ø 5.5 mm	7 x Ø 7.5 mm		3 x Ø 8.5 mm
4 x Ø 6.5 mm	11 x Ø 6.5 mm	8 x Ø 7.5 mm	-	4 x Ø 6.5 mm		11 x Ø 6.5 mm
-	-	-	-	-		-
18 kA	18 kA	22 kA	-	-		-
26 kA	28 kA	36 kA	-	-		-
4.2 kA rms/1 s	4.2 kA rms/1 s	8.4 kA rms/1 s	-	-		-
14	20	18	7	14		17
100 x 126 x 50.5	100 x 162 x 50.5	100 x 174 x 50.5	20 x 70 x 35	20 x 125 x 35		20 x 155 x 35
390	559	567	63	111		149
LGYN12512	LGYN12515	LGYN12512	-	-		-
LGY412548	LGY412560	LGY416048	LGYN1007	LGYN12512		LGYN12515

Terminal technical data

Type	PZ2 screw							
Diameter	Ø 5.5 mm	Ø 5.8 mm	Ø 6 mm	Ø 6.5 mm	Ø 7.5 mm	Ø 8.5 mm	Ø 9 mm	Ø 9.5 mm
Section rigid cable	1.5 to 16 mm ²	1.5 to 16 mm ²	1.5 to 16 mm ²	1.5 to 16 mm ²	2.5 to 25 mm ²	6 to 35 mm ²	10 to 35 mm ²	10 to 35 mm ²
Section flexible cable or with ferrule	1.5 to 10 mm ²	1.5 to 10 mm ²	1.5 to 10 mm ²	1.5 to 10 mm ²	1.5 to 16 mm ²	4 to 25 mm ²	4 to 25 mm ²	6 to 35 mm ²
Tightening torque	2 N.m	2 N.m	2 N.m	2 N.m	2 N.m	2 N.m	2.5 N.m	2.5 N.m
Type	Hc screw							
Diameter	Ø 9.5 mm	Ø 10 mm	Ø 12 mm		Ø 15.3 mm			
Section rigid cable	10 to 35 mm ²	1.5 to 50 mm ²	25 to 70 mm ²		35 to 120 mm ²			
Section flexible cable or with ferrule	6 to 35 mm ²	1.5 to 35 mm ²	16 to 50 mm ²		25 to 95 mm ²			
Tightening torque	8 N.m	4 N.m	1P: 9 N.m	4P: 5 N.m	14 N.m			

Linergy distribution systems

Distribution blocks

Linergy DS

Dimensions

Dimensions (mm)

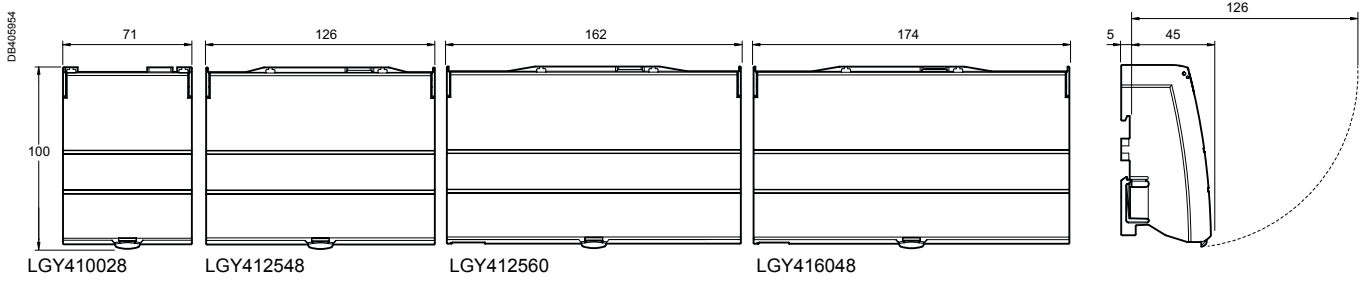
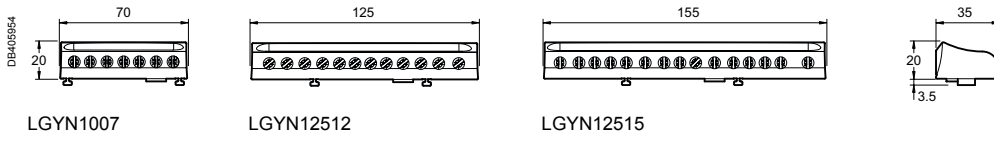
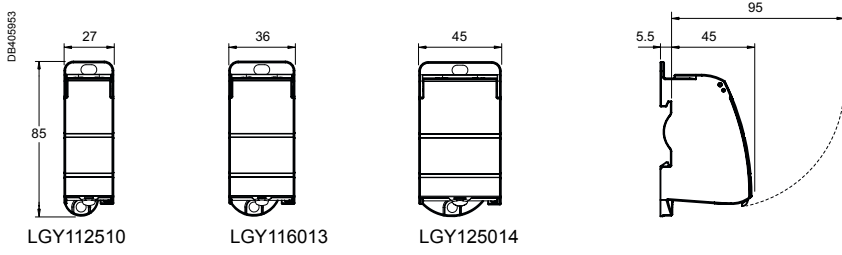



Country approval pictograms



A9XMWD20-41 eps

A9XMWD20

Ethernet connection concentrator (Modbus TCP/IP) for wireless devices with data display web pages.

The associated PowerTag energy sensors allow alarms to be managed via email for terminal loads, and energy, power, current and voltage to be measured accurately in real time.

The associated PowerTag Control modules are designed to monitor a circuit and notify wirelessly to the concentrator the information status of a contact (OF, SD, CT or TL position indication...).

The entire system can easily be installed in existing LV equipments using Multi9/Acti9/Compact NSX type circuit breakers.

Data transmitted:

- Total and partial energy.
- Active power, apparent power, phase-to-phase and phase-to-neutral voltage.
- Currents I1, I2, I3.
- Power factor (cos phi).
- Voltage loss and overload information.
- Control order to a circuit.
- Information status of a contact.

Functions

Acti9 PowerTag Link permits:

- Concentration of PowerTag (covered ranges Acti9 iC40/iC60, Multi9 and Compact NSX) wireless energy sensor data.
- Ethernet connection via the RJ45 port.
- Load monitoring:
 - alarm sent by the energy sensor in the event of a voltage loss,
 - pre-alarms on predefined thresholds (50 %, 80 %) or customized thresholds (thresholds on currents, power, voltages and cumulative energies),
 - load running time counter,
 - power synthesis (kW).
- Alarm management on current/voltage/load level thresholds by e-mail.
- Send control orders to PowerTag Control output to operate a load remotely.
- Collect status of contact from PowerTag Control input.
- Display of alarms and pre-alarms on Acti9 PowerTag Link embedded web pages.
- Easy integration into system with Com'X 200, Com'X 510 and other Schneider Electric software and third-party Building Management Systems (BMS) thanks to EcoStruxure Power Commission report in pdf format. This report provides dynamically all the Modbus registers and associated meanings for an easy integration into the system.
- Remote metering capability using the Acti9 PowerTag Link monitoring page.

Installation

- On DIN rail (width 54 mm).
- 230 V AC power supply.

Testing and start-up

- Pairing of wireless devices must be performed via the EcoStruxure Power Commission software, freely available by downloading.
- The software makes it possible, in particular, to attribute to each circuit a name, a use and the current rating (useful for alarms).

Catalog numbers



Acti9 PowerTag Link

Type		Width in 9-mm modules
Ethernet concentrator (Modbus TCP/IP) up to 20 wireless devices	A9XMWD20	6
Ethernet concentrator (Modbus TCP/IP) up to 100 wireless devices	A9XMWD100	



Commissioning software: EcoStruxure Power Commission (*)

- Configuration and communication test of wireless devices
- Editing of a complete test report (pdf) with the Modbus communication registers for easy integration into a supervision system
- Windows XP, Windows 7, Windows 8 and Windows 10 compatible
- Downloadable from: https://www.schneider-electric.com/ww/en/download/document/Ecoreach_Installer

(*): new name of Ecoreach software



Acti9 PowerTag Link

Compatible products

Circuit breakers and switches:

- Acti9, Multi9, DT60
 - Compact NSX
- See catalog module CA908058



PE11998B-40.eps

PowerTag Energy sensor



LV434821_image-2-80.eps

Acti9 PowerTag Link

- Installation on DIN rail
- 230 V AC power supply



ABXMXD20-34.eps

Ethernet

Ethernet connector
■ 100 Base T - RJ45



ABXMC1D5-27.eps

PowerTag Control I/O module

Wireless communication

- No wiring required
- Up to 100 sensors connected

Technical characteristics

Main characteristics

Supply voltage	Us	110/230 V AC ± 20 %, 2 A
Frequency		50/60 Hz
Power consumption		5 VA
Communication interface		Ethernet 10/100 BASE-T, Cable length ≤ 100 m Cat.6 STP
Wireless communication		Up to 100 PowerTag sensors
Integrated connection type		DHCP client (Ethernet port)
Local indication	Product state	Green, orange and red LED
	Ethernet state (LAN ST)	Green, orange and red LED
Overvoltage category		III
Radio-frequency communication ISM band 2.4 GHz		2.4 GHz to 2.4835 GHz
Degree of protection (IEC 60068-2-30)	Device only	IP20
	Device in modular enclosure	IP40 Insulation class II
Fire resistance		650°C, 30 s
Environment		In compliance with the RoHS directive REACH Regulations

Additional characteristics

Operating temperature		-25°C to +60°C
Storage temperature		-40°C to +85°C
Pollution degree		2
Tropicalization (IEC 60068-2-30)		Treatment 2 (relative humidity of 93 % at 40°C)
Operating altitude		0 to 2000 m
Electromagnetic compatibility	Reference standards	
	Immunity	EN 55035
	Emissions	EN 55032
	Electromagnetic compatibility and Radio spectrum Matters (ERM)	EN 300328 EN 301489-1 EN 301489-17

Weight (g)

Acti9 PowerTag Link

Type

Acti9 PowerTag Link	133
---------------------	-----

Dimensions (mm)

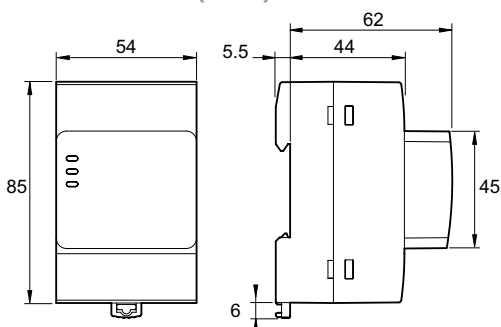

Acti9 PowerTag Link

Acti9 PowerTag Link C



Country approval pictograms



Acti9 PowerTag Link C

Functions

Acti9 PowerTag Link C is a concentrator that connects the switchboard to the Facility Expert SB smartphone app. It permits:

- Load monitoring with PowerTag wireless energy sensors:
 - load state monitoring,
 - energy measurement.
- Temperature monitoring with PowerTag Ambient for Temperature.
- Sending of control orders to PowerTag Control output to operate a load remotely.
- Collection of status of contact from PowerTag Control input.
- Maximum of 20 wireless devices connected.

Configuration, testing and setup

- Connected devices are configured and communication is tested via the "mySchneider Electrician eSetup" app.

Catalog numbers

Acti9 PowerTag Link C		
Type	Set of	
Acti9 PowerTag Link C	1	A9XELC10

Connectable devices

PowerTag A9 M63, P63, F63

Type	Mounting	Cat. no.	M63 for Acti9 and Multi9 Monoconnect	P63 for Acti 9 and Multi9 Phase/Neutral	F63 for other products
1P+wire	Top or bottom	A9MEM1520	-	-	-
1P+N	Top	A9MEM1521	-	A9MEM1561	-
	Bottom	A9MEM1522	-	A9MEM1562	-
	Top or bottom	-	-	-	A9MEM1560
1P+N RCBO	Bottom	-	-	A9MEM1563	-
3P	Top or Bottom	A9MEM1540	-	-	-
		A9MEM1543	-	-	-
3P+N	Top	A9MEM1541	-	A9MEM1571	-
	Bottom	A9MEM1542	-	A9MEM1572	-
	Top or bottom	-	-	-	A9MEM1570

PowerTag Control

Type	Cat. no.
IO 230V	A9XMC1D3

PowerTag Ambient for Temperature

Type	Cat. no.
Temperature	A9XST114

PowerTag NSX

Type	Description	Cat. no.
3P	250 A	LV434020
	630 A	LV434022
3P+N	250 A	LV434021
	630 A	LV434023



PowerTag A9 M63 1P+W (A9MEM1520)



PowerTag A9 M63 3P (A9MEM1540)



PowerTag A9 F63 3P+N (A9MEM1570)



PowerTag A9 P63 1P+N (A9MEM1562)



PowerTag C IO 230V (A9XMC1D3)



PowerTag Ambient for Temperature (A9XST114)



PowerTag NSX (LV434020)



PowerTag NSX (LV434023)

Note: for additional information and list of Schneider Electric compatible devices, refer to the selection guide CA908058E.



Example of an installation with PowerTag compatible A9XELC10

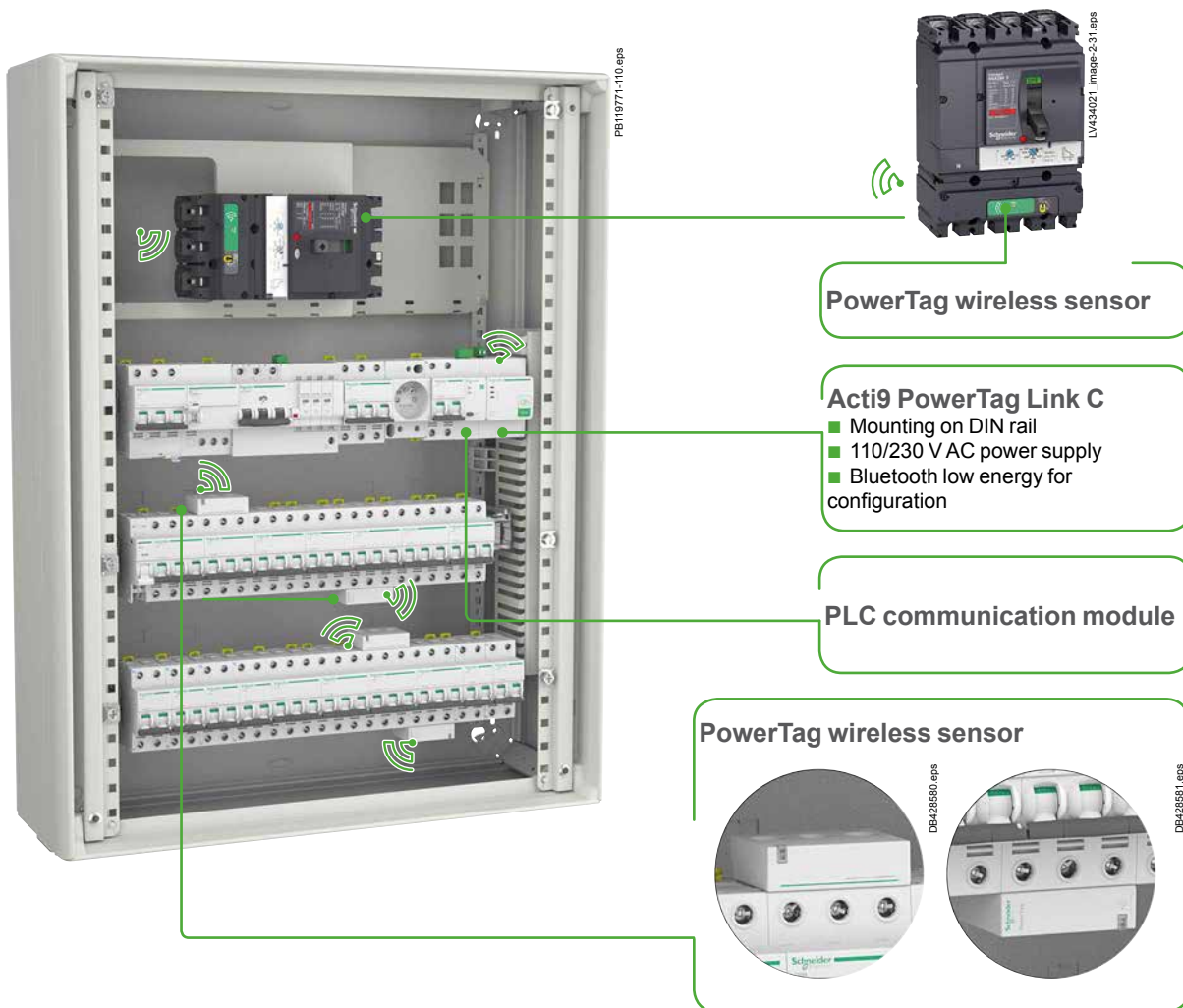
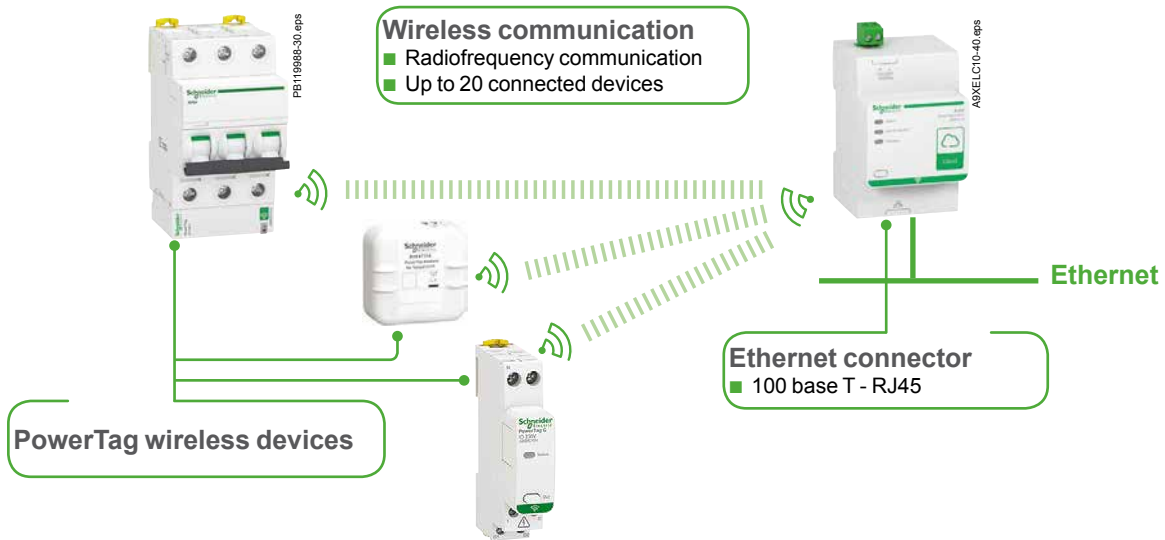



3 options for connecting Acti9 PowerTag Link C to an Internet router

Direct RJ45

Ethernet cable

- 1 Acti9 PowerTag Link C
- 2 Ethernet cable
- 3 Internet router

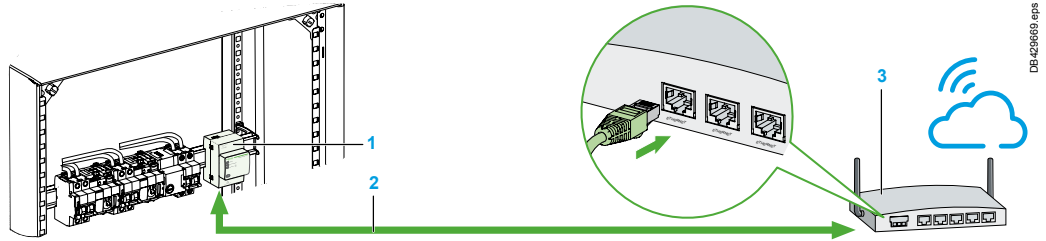

DE429669.eps

Wifi router

- 1 Acti9 PowerTag Link C
- 2 Ethernet cable
- 3 Wifi router
- 4 Internet router

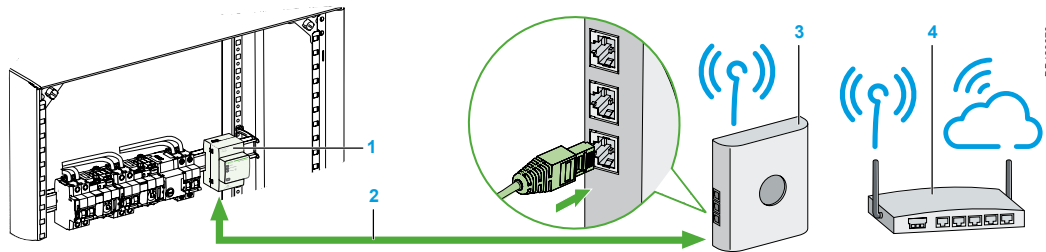

DB429670.eps

Power Line Carrier (PLC)

PLC with 2 PLC plugs

- 1 Acti9 PowerTag Link C
- 2 Ethernet cable
- 3 PLC adapter
- 4 Internet router

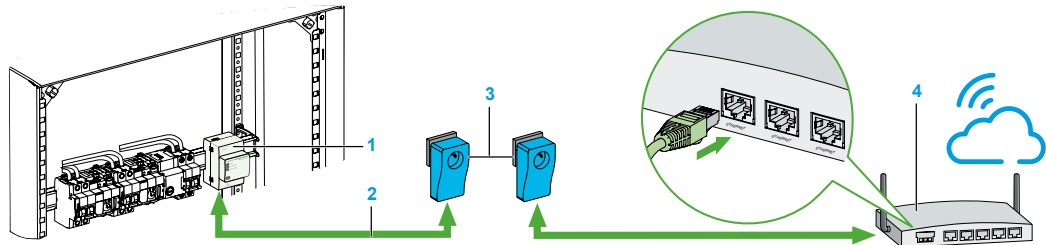

DB429671.eps

PLC with 1 PLC DIN rail adapter and 1 PLC plug



EER31700_image-38.eps

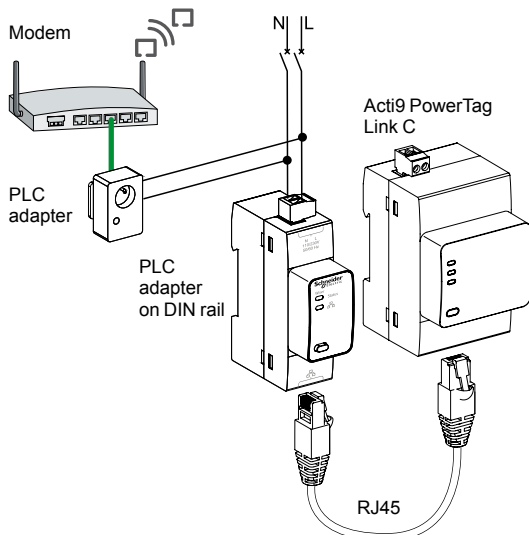

DE429445_Modifie.eps

Type	Cat. no.
PLC adapter on DIN rail	EER31710

Acti9 PowerTag Link C (continued)



Technical characteristics

Power supply		
Rated		<ul style="list-style-type: none"> ■ 110/230 V AC ± 15% ■ Non-isolated with protection against voltage reversals to -28.8 V---
Maximum input current		1.5 A
Voltage limit		19.2...28.8 V--- with ripple
Maximum inrush current		3 A
Overvoltage category		OVC III
No-load consumption		100 mA
Environmental characteristics		
Temperature	Operating (horizontal)	-25°C...+60°C
	Storage	-40°C...+85°C
Tropicalization		Treatment 2 (relative humidity: 93 % at 40°C)
Resistance to voltage dips		10 ms, class 3 as per IEC 61000-4-29
Degree of protection	Front panel	IP40
	Box	IP20
Degree of pollution		2
Compliance with SELV specifications		Yes
Altitude	Operating	0...2000 m
	Storage	0...3000 m
Vibration resistance	As per IEC 60068-2-6	1 g / ± 3.5 mm - 5 Hz to 300 Hz - 10 cycles
Shock resistance	As per IEC 60068-2-27	15 g / 11 ms
Immunity to electrostatic discharge	As per IEC 61000-4-2	<ul style="list-style-type: none"> ■ Air: 8 kV ■ Contact: 4 kV
Immunity to radiated magnetic fields	As per IEC 61000-4-3	10 V/m - 80 MHz to 3 GHz
Immunity to fast transients	As per IEC 61000-4-4	<ul style="list-style-type: none"> ■ 1 kV for Ethernet communication ■ 2 kV for 24 V--- power supply - 5 kHz - 100 kHz
Immunity to conducted magnetic fields	As per IEC 61000-4-6	10 V from 150 kHz to 80 MHz
Immunity to magnetic fields at mains frequency	As per IEC 61000-4-8	<ul style="list-style-type: none"> ■ 30 A/m continuous ■ 100 A/m pulsed
Resistance to corrosive atmospheres	As per IEC 60721-3-3	Level 3C2 on H ₂ S / SO ₂ / NO ₂ / Cl ₂
Fire resistance	For live parts	At 960°C 30 s / 30 s as per IEC 60 695-2-10 and IEC 60 695-2-11
	For other parts	At 650°C 30 s / 30 s as per IEC 60 695-2-10 and IEC 60 695-2-11
Salt spray mist	As per IEC 60068-2-52	Severity 2
Environment		In compliance with RoHS directives
Overvoltage	As per IEC 61000-4-5	<ul style="list-style-type: none"> ■ Power supply: 0.5 kV ■ Ethernet: 1 kV
Conducted emissions	IEC 61131-2, CISPR	Class A: (0.15 to 30 MHz)
Radiated emissions	IEC 61131-2, CISPR	Class A: (30 to 1000 MHz)
Mean time between failures		More than 1 M hours
Additional characteristics		
Mounting position		Horizontal or vertical
Ethernet characteristics		
Type of interface module		Ethernet
Transmission	Ethernet	<ul style="list-style-type: none"> ■ Transfer rate: 10/100 Mbit/s ■ Medium: straight shielded cable, STP or S/FTP, Cat 5e or 6, RJ45 connector
Turnaround time		1 ms
Maximum cable length		100 m
Type of bus connector		RJ45 (shielded)
Number of Ethernet ports		1
Radiofrequency characteristics		
Radio communication ISM band		2.4 to 2.4835 GHz
Number of channels		11 to 26 (IEEE 802.15.4)
Equivalent isotropically radiated power (EIRP)		0 dBm
Number of radiofrequency devices		Up to 20 PowerTag energy sensors
RF standard		ETSI / EN 300328 v2.1.1 ETSI / EN 301489-17 v3.2.0

Monitoring and measurement for small business

Acti9 PowerTag Link C (continued)



Dimensions (mm)

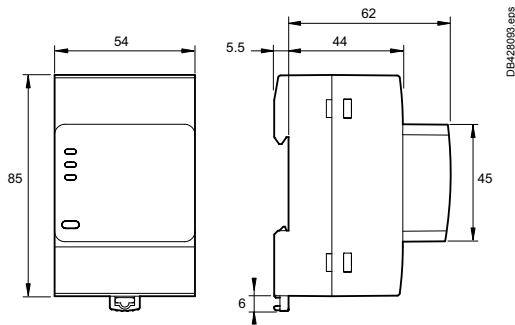

Acti9 PowerTag Link C

Weight (g)

Smartlink	
Type	
Acti9 PowerTag Link C	133

Connection

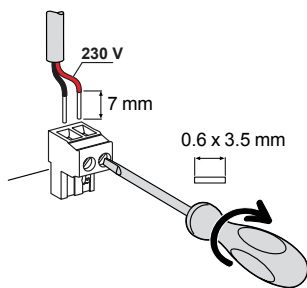

Terminal	Tightening torque	Copper cables		
		Rigid	Flexible	Flexible with ferrule
DB428033.eps		DB122845.eps	DB122853.eps	DB122854.eps
Power supply connector	0.8 Nm	0.2 to 1.5 mm ²	0.2 to 1.5 mm ²	0.2 to 1.5 mm ²

Installation

- On DIN rail (width 54 mm).
- 230 V AC power supply.



Country approval pictograms



Acti9 Smartlink EL B

PB113286-modifie-66.eps



PB107797-44.eps

Functions

Acti9 Smartlink EL B is a gateway that connects the switchboard to the Facility Expert SB smartphone app.

■ Circuit breakers, residual current circuit breakers, residual current devices:

- open/closed state,
- tripped state.

■ Contactors, impulse relays:

- opening control,
- closing control,
- open/closed state.

■ RCA remote control:

- reset control after tripping,
- open/closed state,
- tripped state.

■ Pulse power meters:

- number of pulses recorded,
- pulse value setting (e.g. kWh).

■ Analogue sensors:

- temperature sensor,
- humidity sensor,
- CO₂ detector,
- etc.

When Acti9 Smartlink EL B is switched on and the Internet connection is available, communication automatically adjusts to Ethernet (Cloud) communication parameters.



DB428885-70.eps

Configuration, testing and setup

■ Connected devices are configured and communication and cabling are tested via the "mySchneider Electrician eSetup" app.



Acti9 Smartlink EL B

PB113286-modif1e-66.eps

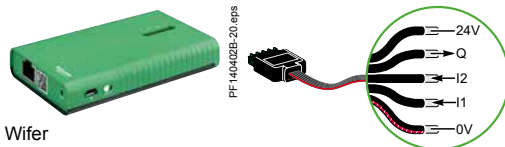

Wifer

A9XCAU06

DB428089.eps



24 V DC power supply

ABL8MEM24003-30.eps

Catalog numbers

Smartlink			
Type		Set of	
Acti9 Smartlink EL B		1	A9XELC08
Supplied with	Connector for 4-pin analogue input	1	
	24 V DC power supply connector	1	
	Mounting kit	1	A9XMFA04
Mounting kit	DIN rail (4 feet, 4 straps, 4 adapters)	1	A9XMFA04
	Back panel (2 angle brackets)	1	A9XMBP02
	Pragma and Kaedra mounting (see table below)	1	A9XMVA01
	Accessories		
Wifer, wifi adapter for setup if no wifi available		1	TCSEGWB13FA0
Prefabricated cables			
With 2 connectors	100 mm	6	A9XCAS06
	160 mm	6	A9XCAM06
	450 mm	6	A9XCAH06
	870 mm	6	A9XCAL06
With 1 connector	870 mm	6	A9XCAU06
	4000 mm	1	A9XCAC01
Connectors	5-pin connectors (Ti24)	12	A9XC2412
	24 V DC power supply		
	With iATL, iACT or RCA	1	ABL8MEM24012
	Without iATL, iACT or RCA	1	ABL8MEM24003

Connectable devices

With Ti24 interface		
Type	Cat. no.	Description
iACT24	A9C15924	Low-level control and indication auxiliary for iCT contactors
iATL24	A9C15424	Low-level control and indication auxiliary for iTL impulse relays
iOF+SD24	A9A26897	Low-level indication auxiliary for iC60, iID, ARA, RCA, iSW-NA
	A9A26898	
	A9N26899	
RCA	See module CA904011	Remote control with Ti24 interface
Without Ti24 interface		
Power meters with pulse output e.g. iEM2000T		
Impulse meters complying with the IEC 62053-21 standard		
With analogue outputs		
Temperature and humidity sensors with 0-10 V or 4-20 mA output		
CO ₂ detectors with 0-10 V or 4-20 mA output		

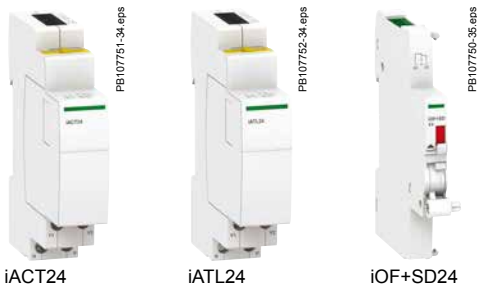

iACT24

iATL24

iOF+SD24



RCA



iEM3110



iEM2000T

Example of an installation

24 modules min.

150 mm min.

1 analogue input channel
■ Example: temperature sensor connection

24 V DC power supply

Prefabricated cables
■ For devices **without** Ti24 interface

Input I1

Input I2

Prefabricated cables
■ For devices **with** Ti24 interface
■ Simplified and faster cabling

Ti24 connector
7 input/output channels
Input protected against voltage reversals
Output protected by current limitation

- Pin 1: 0 V
- Pin 2: I1 Input 1
- Pin 3: I2 Input 2
- Pin 4: Q output
- Pin 5: +24 V DC

24 V DC power supply connector
Input protected against voltage reversals

- Pin 1: 0 V
- Pin 2: +24 V DC

Ethernet + Cloud connector
100 base T - RJ45



Analogue connector
2 configurable input points
0-10 V or 4-20 mA

- Pin 1: 0 V
- Pin 2: AI1 Input 1
- Pin 3: AI2 Input 2
- Pin 4: +24 V DC

Status indication
■ Indication of the operation of the communication system and the status of Smartlink EL B

Not used

Options for connecting Acti9 Smartlink EL B to an Internet router

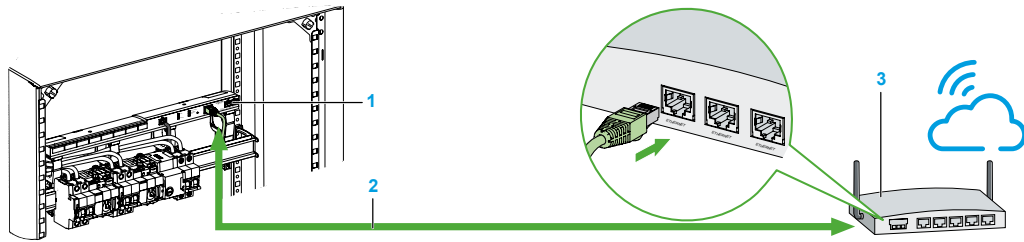

DB428446.eps

RJ45 Ethernet cable

- 1 Acti9 Smartlink EL B
- 2 Ethernet cable
- 3 Internet router

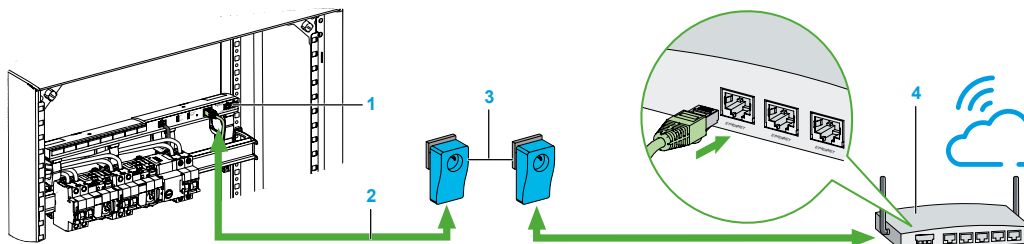

PLC

- 1 Acti9 Smartlink EL B
- 2 Ethernet cable
- 3 PLC adapter
- 4 Internet router

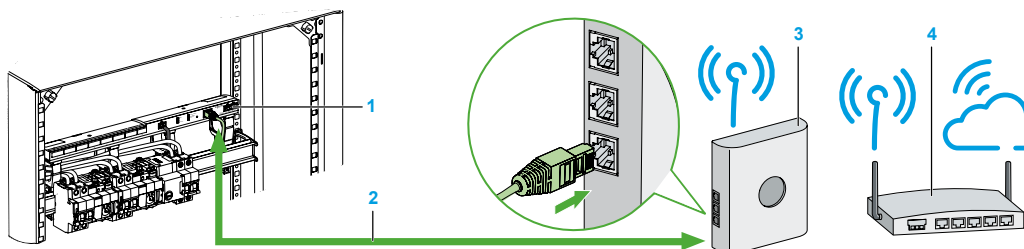

Wifi router

- 1 Acti9 Smartlink EL B
- 2 Ethernet cable
- 3 Wifi router
- 4 Internet router

Option for connecting a PLC module to a switchboard using a DIN adapter

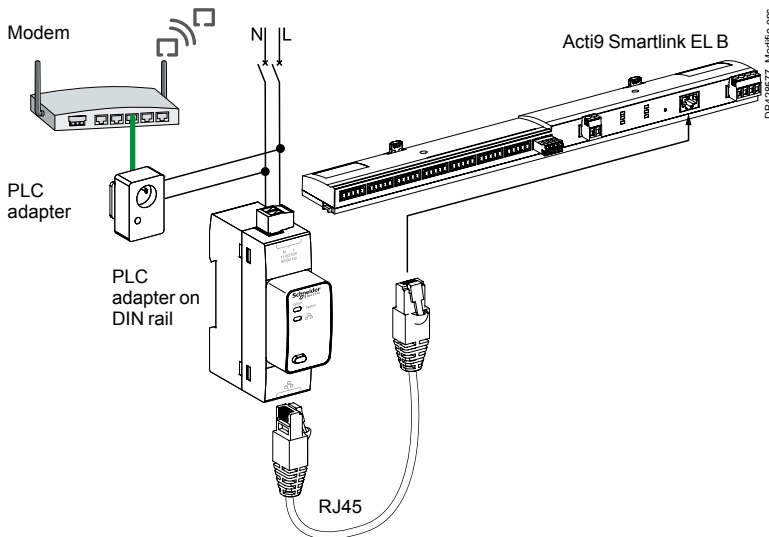

DB428377_Modfile.eps



EER31710_image-38.eps

Type	Cat. no.
PLC adapter on DIN rail	EER31710

Acti9 Smartlink EL B (continued)

Technical characteristics

Power supply		
Rated		24 V DC \pm 20%
Maximum input current		1.5 A
Maximum inrush current		3 A
Overvoltage category		OVC II
No-load consumption		110 mA
Meter		
Capacity		2 ³² pulses per input
Digital input characteristics		
Number of channels		7 x 2-input channels Device with TI24 interface: 1 channel, 2 inputs used Device without TI 24 interface: (power meter, impulse meter) 1 input used
Type of input		Current collector Type 1, IEC 61131-2
Maximum cable length		500 m
Rated voltage		24 V DC
Voltage limits		24 V DC \pm 20%
Rated current		2.5 mA
Maximum current		5 mA
Filtering time	State 1	2 ms
	State 0	2 ms
Isolation		No isolation between channels
Voltage reversal protection		Yes
Analogue input characteristics		
Number		2
Type		Separate configuration for each input: 0-10 V or 4-20 mA
Measuring accuracy		1/100 full scale
Resolution		12 bits
Acquisition time		500 ms
Isolation		No isolation between channels
Power supply		0-24 V DC
Type of cable		Shielded twisted pair
Maximum cable length		30 m
Protection		Short-circuit protection
Output characteristics		
Number of output channels		7
Type of output		24 V DC - 0.1 A current source
Maximum cable length		500 m
Rated voltage	Voltage	24 V DC
	Maximum current	100 mA
Filtering time	State 1	2 ms
	State 0	2 ms
Voltage drop (voltage at state 1)		1 V max
Maximum inrush current		500 mA
Leakage current		0.1 mA
Overvoltage protection		33 V DC

Technical characteristics (continued)

Environmental characteristics		
Temperature	Operating	-25°C...+60°C (if vertical mounting, limited to 50°C)
	Storage	-40°C...+80°C
Tropicalization		Treatment 2 (relative humidity: 93 % at 40°C)
Resistance to voltage dips		10 ms, class 3 as per IEC 61000-4-29
Degree of protection		IP20
Degree of pollution		3
Altitude	Operating	0...2000 m
Vibration resistance	As per IEC 60068-2-6	1 g / ± 3.5 mm - 5 Hz to 300 Hz - 10 cycles
Shock resistance	As per IEC 60068-2-2-7	15 g / 11 ms
Immunity to electrostatic discharge	As per IEC 61000-4-2	<ul style="list-style-type: none"> ■ Air: 8 kV ■ Contact: 4 kV
Immunity to radiated magnetic fields	As per IEC 61000-4-3	10 V/m - 80 MHz to 3 GHz
Immunity to fast transients	As per IEC 61000-4-4	<ul style="list-style-type: none"> ■ 1 kV for inputs/outputs ■ 1 kV for the communication bus ■ 2 kV for 24 V DC power supply - 5 kHz - 100 kHz
Immunity to conducted magnetic fields	As per IEC 61000-4-6	10 V from 150 kHz to 80 MHz
Immunity to magnetic fields at mains frequency	As per IEC 61000-4-8	30 A/m
Resistance to corrosive atmospheres	As per IEC 60721-3-3	Level 3C2 on H ₂ S / SO ₂ / NO ₂ / Cl ₂
Fire resistance	For live parts	At 960°C 30 s / 30 s as per IEC 60 695-2-10
	For other parts	At 650°C 30 s / 30 s as per IEC 60 695-2-10
Salt spray mist	As per IEC 60068-2-52	Severity 2
Environment		In compliance with RoHS directives
Additional characteristics		
Memory backup period		10 years
Prefabricated cable characteristics		
Dielectric strength		1 kV / 5 min
Minimum draw-out resistance		20 N
Ethernet characteristics		
Link		10/100 Mbit/s Ethernet
Turnaround time		1 ms
Maximum cable length		100 m
Type of bus connector		RJ45 (shielded)
Number of Ethernet ports		1

Dimensions (mm)

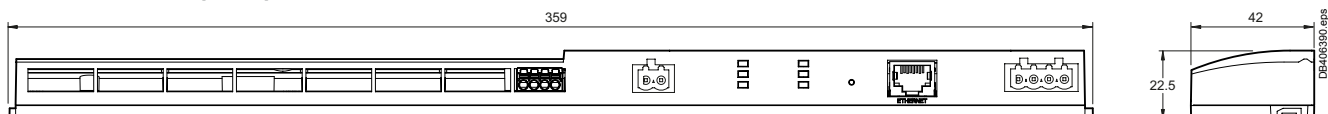

Acti9 Smartlink EL B

Weight (g)

Smartlink

Type

Acti9 Smartlink EL B	180
----------------------	-----

Connection

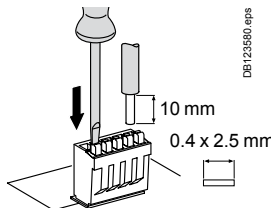
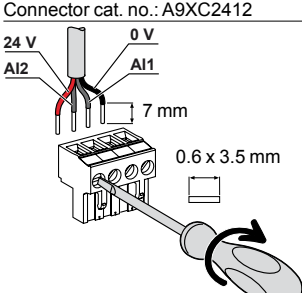
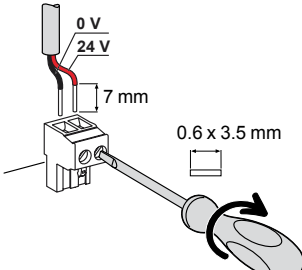
	Terminal	Tightening torque	Copper cables		
			Rigid	Flexible	Flexible with ferrule
 <p>Connector cat. no.: A9XC2412</p>	Ti24 interface	Spring-loaded terminals	0.5 to 1.5 mm ²	0.5 to 1.5 mm ²	-
	Analogue connector	0.8 Nm	0.1 to 1.5 mm ²	0.1 to 1.5 mm ²	0.1 to 1.5 mm ²
	Power supply connector	0.8 Nm	0.2 to 1.5 mm ²	0.2 to 1.5 mm ²	0.2 to 1.5 mm ²

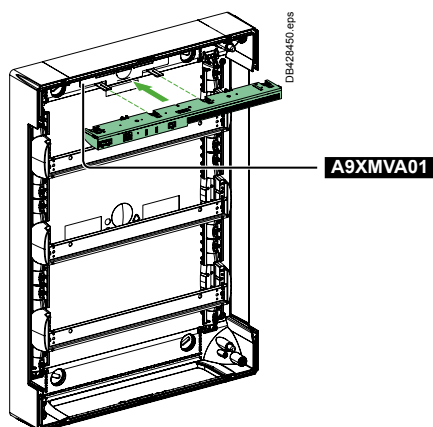

Pragma enclosure horizontal mounting

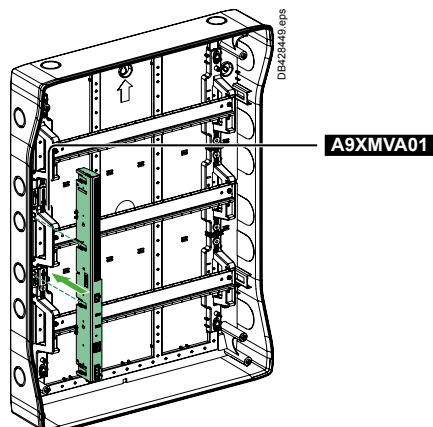

Kaedra enclosure vertical mounting

Installation

- Horizontal mounting in switchboards by fitting behind the DIN rail using mounting kit **A9XMFA04**:
 - width 24 modules per row,
 - minimum spacing between rails 150 mm.
- Mounting in Pragma and Kaedra enclosures with mounting kit **A9XMVA01** (see table below).

Installation in Kaedra and Pragma enclosures	Kit A9XMVA01	
	Vertical	Horizontal
Kaedra		
13M 3R	☑	
18M 3R	☑	
18M 1R, 2R, 3R, 4R		☑
Pragma		
13M 3R,4R	☑	
18M 3R,4R	☑	
18M 1R, 2R, 3R, 4R		☑
24M 1R, 2R		☑
24M 3R, 4R, 5R, 6R	☑	☑



CE

Country approval pictograms

PB107797-47



DB404502

ComReady



IEC/EN 61131-2

The Acti9 Smartlink SI B is an open system that remotely measures, balances, monitors and controls final distribution.

It is designed to fit into tertiary building projects and integrates perfectly in a Building Management System or an Energy Management System.

It consists of:

- a Modbus Slave version (Acti9 Smartlink Modbus)
- a Modbus Master version (Acti9 Smartlink SI B) with the following functions: radio hub, Modbus gateway and embedded web server: this provides web pages for configuring the system, and real-time monitoring of values (status of circuit breakers, energy meters, alarms and monitoring and control). These modules transmit data to a PLC or monitoring system.

The system supports

- Alarm monitoring on current, voltage, power factor, tripping, power, consumption thresholds and their transmission by email.
- Monitoring and control via web pages of loads, energy and power by zone and by usage.
- Single access point for a full analysis of the status of switchboard power distribution (measurements, protection status, temperature, consumption, alarms, control and monitoring).

Functions

Transmission of data collected by Acti9 switchgear assemblies

- Circuit breakers, residual current circuit breakers and residual current devices:
 - open/closed state, tripped state,
 - number of opening/closing cycles,
 - number of tripping actions.
- Contactors, impulse relays, Reflex iC60:
 - opening and closing control,
 - open/closed state,
 - number of opening/closing cycles,
 - total period of operation of the load (device closed).
- Remote controlled circuit breaker/Reflex iC60:
 - opening control ,
 - closing control ,
 - contactor open/closed state,
 - circuit breaker open/closed state,
 - number of opening/closing cycles,
 - total period of operation of the load.
- Pulse meters (energy, water, gas, etc.):
 - number of pulses recorded,
 - pulse value setting (default: 10 Wh),
 - total consumption recorded,
 - possibility of resetting energy meters.
- Digital inputs/outputs.

Acti9 Smartlink SI B



DB429005

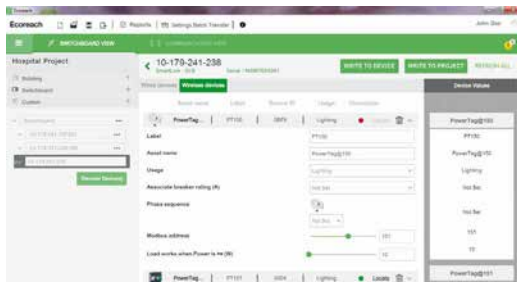

Functions (cont.)

Transmission of additional data collected by Acti9 Smartlink SI B

- Power meters (Modbus slaves).
- Analog sensors:
 - CO₂ sensor,
 - light sensor,
 - humidity sensor,
 - temperature sensor,
 - any 0..10 V or 4..20 mA compatible sensor.
- PowerTag wireless-communication energy sensors (Compact NSX, Acti9 iC60, iC40, DT60, DT40 ranges):
 - total and partial energy,
 - active power, phase-to-phase voltage, phase-to-neutral,
 - currents I1, I2, I3,
 - power factor,
 - voltage loss and overload information.
- Load monitoring:
 - alarm sent by the sensor in the event of a voltage loss,
 - pre-alarms on predefined thresholds (50 %, 80 %) or customized thresholds (thresholds on currents, power, voltages and cumulative energies),
 - load running time counter.
- Alarm management on current/voltage/load level thresholds by e-mail.
- Display of alarms and pre-alarms on Acti9 Smartlink SI B embedded web pages.
- Easy integration into any upper system using Com'X 210, Com'X 510 and other Schneider Electric software and third-party Building Management Systems (BMS's) thanks to the EcoStruxure Power Commission report in pdf format. A report provides dynamically all the Modbus registers and associated meanings for an easy integration into the system.
- Remote metering capability using the Acti9 Smartlink SI B monitoring page.

All the data are stored in memory: number of cycles, consumption, period of operation, even in the event of a power interruption.

Acti9 Smartlink can also exchange data with any device having 24 V DC digital inputs/outputs (e.g. low-level contacts 29452 for position of the Compact NSX). No configuration of the products connected to the Ti24 channels is required.

At power up, Acti9 Smartlink Modbus adapts automatically to the communication parameters of the Modbus master (PLC, supervisor, etc.).

Installation

- Assembly in switchboards:
 - width 24 modules per row,
 - minimum spacing between rails 150 mm.
- Mounting on:
 - DIN rail with mounting kit **A9XMFA04**,
 - Linergy FM 80 A, with bolts provided,
 - Linergy FM 200 A, with mounting kit **A9XM2B04**,
 - back of enclosure with mounting kit **A9XMBP02**,
- Installation in Pragma and Kaedra enclosures with mounting kit **A9XMVA01**.

Test

- The communication and cabling test on the connected devices can be performed using the EcoStruxure Power Commission software.

DB-405140

Commissioning software: EcoStruxure Power Commission (*)

- Configuration and communication test of wired and wireless devices 
- Editing of a complete test report (pdf) with the Modbus communication registers for easy integration into a supervision system
- Windows XP, Windows 7, Windows 8 and Windows 10 compatible
- Downloadable from:
https://www.schneider-electric.com/ww/en/download/document/Ecoreach_Installer

(*): new name of Ecoreach software



Acti9 Smartlink SI B



Acti9 Smartlink Modbus

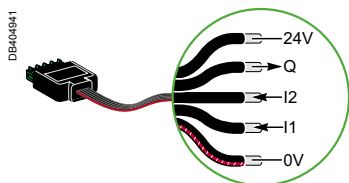

A9XCAU06



Catalogue numbers

Acti9 Smartlink

Type	Set of	
Acti9 Smartlink SI B	1	A9XMZA08
Supplied with		
4-pin connector for analog inputs	1	
Modbus connector	1	
24 V DC power supply connector	1	
Bolts for mounting on Linergy FM 80	2	
Acti9 Smartlink Modbus	1	A9XMSB11
Supplied with		
Modbus connector	1	
24 V DC power supply connector	1	
Bolts for mounting on Linergy FM 80	2	
Accessories		
USB/Modbus connecting cables for Acti9 Smartlink test	1	A9XCATM1
Prefabricated cables		
With 2 connectors		
100 mm	6	A9XCAS06
160 mm	6	A9XCAM06
450 mm	6	A9XCAH06
870 mm	6	A9XCAL06
With 1 connector		
870 mm	6	A9XCAU06
4000 mm	1	A9XCAC01
Connectors	5-pin connectors (Ti24)	12 A9XC2412
Mounting kit		
DIN rail (4 feet, 4 earthing straps, 4 adapters)	1	A9XMFA04
Linerage FM 200 A (4 adapters)	1	A9XM2B04
Back of enclosure (2 brackets)	1	A9XMBP02
Vertical for Kaedra enclosures	1	A9XMVA01
Vertical or horizontal for Pragma enclosures		
Spare parts	Bolts for Linergy FM 80 A (2 bolts)	1 A9XMLA02

Connectable devices

With Ti24 interface

Type	Reference	Description
iACT24	A9C15924	Low-level control and indication auxiliary for iCT contactors
iATL24	A9C15424	Low-level control and indication auxiliary for iTL impulse relays
iOF+SD24	A9A26897 A9A26898	Low-level indication auxiliary for iC60, iID, ARA, RCA, iSW-NA
OF+SD24	A9N26899	Low-level indication auxiliary for C60, C120, DPN, RCCB/ID, C60H-DC
RCA iC60	See module CA904011	Remote control with Ti24 interface
Reflex iC60	See module CA904012	Reflex iC60 with Ti24 interface

Without Ti24 interface

Power meters with pulse output, e.g. iEM2000T
Pulse meters complying with the IEC 62053-21 standard
24 V DC indicator lamps, Harmony range type XVL
All loads not exceeding 100 mA, 24 V DC
Timers, thermostats, time switches, load shedding devices
All 24 V DC auxiliary contacts, IEC 61131-2 type 1

With Modbus connector systems

Power meters: iEM3150, iEM3250, iEM3350, iEM3155, iEM3255, iEM3355, all Modbus slave RS485 equipment

With wireless-communication systems

PowerTag energy sensors *. See catalog module CA907029E

With analog outputs

Any 0...10 V and 4...20 mA compatible sensor (temperature, humidity, luminosity, etc.)

(*) for additional information and a list of Schneider Electric compatible devices, refer to the selection guide CA908058E.



Example of an installation

Modbus master
■ Acti9 Smartlink SI B

Ethernet link
■ Ethernet 10/100 MB, Modbus TCP server

Wireless communication
■ No additional wiring
■ Up to 20 sensors connected

Analog inputs
■ 2 analog inputs, 0..10 V or 4..20 mA, e.g.: connection of a temperature probe

Modbus communication
■ Up to 8 Acti9 Smartlink Modbus or other Modbus slaves connected

Prefabricated cables
■ Simplified and faster cabling

Modbus slave
■ Acti9 Smartlink Modbus

Ethernet network connection

Acti9 Smartlink SI B has an embedded Web server used to display data showing the state of circuit breakers, energy meters, power data, phase unbalance and current alarms.

Manual control is also possible via the Web page.

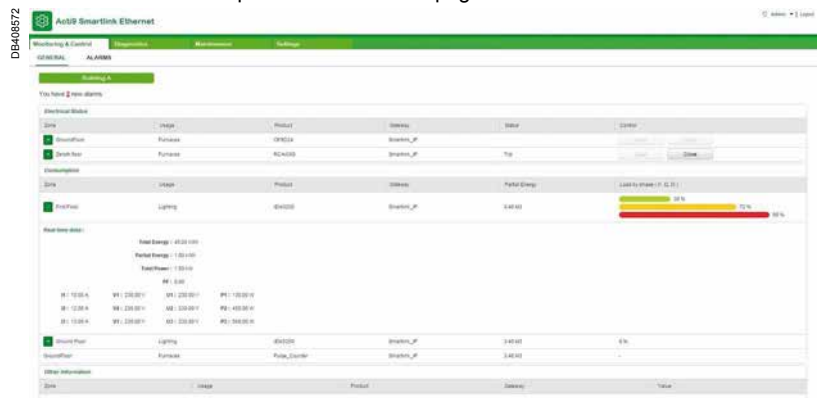

■ The Web server sets the parameters of the connection to the network servers (SNTP, SMTP), as well as the parameters of user emails and of the connection to the Facility Hero.com service



Acti9 Smartlink SI B (A9XMZA08)

Ti24 connector
7 input/output channels
Input protected against voltage reversals
Output protected by current limiting

- Pin 1: 0 V
- Pin 2: I1 Input 1
- Pin 3: I2 Input 2
- Pin 4: Q Output
- Pin 5: +24 V DC

24 V DC power supply connector
Input protected against voltage reversals

- Pin1: 0 V
- Pin2: +24 V DC

Ethernet connector
100 Base T - RJ45

Analog connector
2 configurable input points, either 0-10 V or 4-20 mA

- Pin 1: 0 V
- Pin 2: AI1 Input 1
- Pin 3: AI2 Input 2
- Pin 4: +24 V DC

20 PowerTag energy sensors
Radio-frequency communication

- ISM band 2.4 GHz (2.4 GHz to 2.4835 GHz)
- Channels 11 to 16 as per IEEE 802.15.4

Note: Acti9 Smartlink SI B and the PowerTag must be installed in the same switchboard

Serial port connector
Modbus (Master) RS485

- Pin 1: D1 Modbus
- Pin 2: D0 Modbus
- Pin 3: shielding
- Pin 4: common/0 V

Indication

- Indication of operation of the communication system and the state of the Acti9 Smartlink SI B

Acti9 Smartlink Modbus (A9XMSB11)

Ti24 connector
11 input/output channels
Input protected against voltage reversals
Output protected by current limiting

- Pin 1: 0 V
- Pin 2: I1 Input 1
- Pin 3: I2 Input 2
- Pin 4: Q Output
- Pin 5: +24 V DC

24 V DC power supply connector
Input protected against voltage reversals

- Pin1: 0 V
- Pin2: +24 V DC

Serial port connector
Modbus (Master) RS485

- Pin 1: D1 Modbus
- Pin 2: D0 Modbus
- Pin 3: shielding
- Pin 4: common/0 V

Indication

- indication of operation of the communication system and the state of the Acti9 Smartlink Modbus

Thumbwheels

- Definition of the address in the Modbus network



Common technical characteristics

Power supply		
Nominal		24 V DC ± 20 %
Maximum input current		1.5 A
Maximum inrush current		3 A
Meter		
Capacity		2 ³² pulses per input
Input characteristics		
Number of channels	Acti9 Smartlink Modbus (A9XMSB11)	11 2-input channels
	Acti9 Smartlink SI B (A9XMZA08)	7 2-input channels
Type of input		Current collector Type 1 IEC 61131-2
Maximum cable length		500 m
Rated voltage		24 V DC
Voltage limits		24 V DC ± 20 %
Rated current		2.5 mA
Maximum current		5 mA
Filtering time	A l'état 1	2 ms
	A l'état 0	2 ms
Isolation		No isolation between channels
Negative sequence voltage protection		Yes
Output characteristics		
Number of output channels	Acti9 Smartlink Modbus (A9XMSB11)	11
	Acti9 Smartlink SI B (A9XMZA08)	7
Type of output		24 V DC - 0.1 A current source
Maximum cable length		500 m
Rated voltage	Voltage	24 V DC
	Maximum current	100 mA
Filtering time	In state 1	2 ms
	In state 0	2 ms
Voltage drop (voltage in state 1)		1 V max
Maximum inrush current		500 mA
Leakage current		0.1 mA
Overvoltage protection		33 V DC
Environmental characteristics		
Temperature	Operating	-25°C ... +60°C (if vertical mounting, limited to 50°C)
	Storage	-40°C ... +80°C
Tropicalization		Treatment 2 (relative humidity of 93 % at 40°C)
Resistance to voltage dips		10 ms, class 3 as per IEC 61000-4-29
Degree of protection		IP20
Pollution degree		3
Altitude	Operating	0 ... 2000 m
Vibration resistance	As per IEC 60068.2.6	1 g / ± 3.5 mm - 5 Hz to 300 Hz - 10 cycles
Shock resistance	As per IEC 60068.2.27	15 g / 11 ms
Immunity to electrostatic discharge	As per IEC 61000-4-2	Air: 8 kV Contact: 4 kV
Immunity to radiated magnetic fields	As per IEC 61000-4-3	10 V/m - 80 MHz to 3 GHz
Immunity to fast transients	As per IEC 61000-4-4	1 kV for inputs/outputs and Modbus communication. 2 kV for 24 V DC power supply - 5 kHz - 100 kHz
Immunity to conducted magnetic fields	As per IEC 61000-4-6	10 V from 150 kHz to 80 MHz
Immunity to magnetic fields at mains frequency	As per IEC 61000-4-8	30 A/m
Resistance to corrosive atmospheres	As per IEC 60721-3-3	Level 3C2 on H ₂ S / SO ₂ / NO ₂ / Cl ₂
Fire resistance	For live parts	At 960°C 30 s / 30 s as per IEC 60 695-2-10 and IEC 60 695-2-11
	For other parts	At 650°C 30 s / 30 s as per IEC 60 695-2-10 and IEC 60 695-2-11
Salt spray test	As per IEC 60068.2.52	Severity 2
Environment		In compliance with the RoHS directive
Prefabricated cable characteristics		
Dielectric strength		1 kV / 5 min
Minimum draw-out resistance		20 N
Electromagnetic compatibility		
Reference standards	Immunity	EN 55024
	Emissions	EN 55022
	Electromagnetic compatibility and Radio spectrum Matters (ERM)	EN 300328 EN 301489-1 EN 301489-17



Acti9 Smartlink Modbus (A9XMSB11) technical characteristics

Characteristics of the Modbus link		
Link	Modbus, RTU, RS485 serial connection	
Transmission	Transfer rate	9600 baud ... 19200 baud, self-adaptable
	Medium	Shielded cable, double twisted pair
Protocol	Master/Slave	
Type of device	Slave	
Modbus addressing range	1 to 99	
Maximum length of the bus	1000 m	
Type of bus connector	4-pin connector	

Acti9 Smartlink SI B (A9XMZA08) technical characteristics

Characteristics of the Ethernet link		
Link	Ethernet 10/100 MB	
Protocol	Modbus TCP server	
	http (web pages)	
Addressing mode	Static and dynamic (supplied, by default, in dynamic mode)	
Gateway characteristics		
Protocol	Modbus TCP/IP -> Modbus SL	
Number of Modbus slaves	8	
Modbus addressing range	1 to 247	
Characteristics of the Modbus Master link		
Link	Modbus, RTU, RS485 serial connection	
Transmission	Transfer rate	9600 bauds ... 19200 bauds
	Medium	Shielded cable, double twisted pair
Maximum length of the bus	1000 m	
Type of bus connector	4-pin connector	
Characteristics of analog inputs		
Number	2	
Type	Independent settings for each input, either 0-10 V or 4-20 mA	
Measuring accuracy	1/100 full scale	
Resolution	12 bits	
Acquisition time	500 ms	
Isolation	No isolation between channels	
Power supply	0-24 V DC	
Cable type	Shielded cable, twisted pair	
Maximum cable length	30 m	
Protection	Short-circuit protection	
Characteristics of the wireless-communication link		
Compatible devices	PowerTag energy sensors	
Maximum number of sensors	20	
Radio-frequency communication	2.4 GHz to 2.4835 GHz at 0 dBm	

Dimensions (mm)

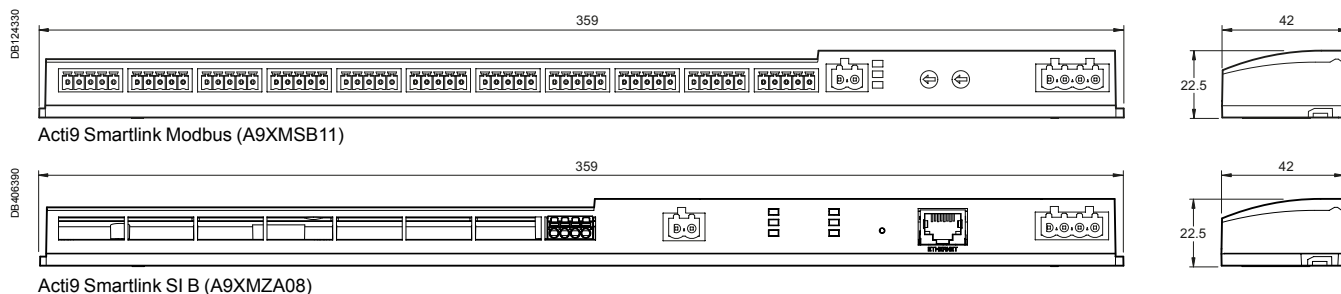

Weight (g)

Acti9 Smartlink	
Type	
Acti9 Smartlink Modbus (A9XMSB11)	195
Acti9 Smartlink SI B (A9XMZA08)	180

Monitoring, control and measurement

Acti9 Smartlink SI B (cont.)



Connection

	Terminal	Tightening torque	Copper cables		
			Rigid	Flexible	Flexible with ferrule
<p>DB123560</p> <p>10 mm 0.4 x 2.5 mm</p> <p>Connector ref: A9XC2412</p>	Ti24 interface	Spring-loaded terminals	DB122945	DB123953	DB123954
<p>DB406517</p> <p>24 V 0 V AI2 AI1</p> <p>7 mm 0.6 x 3.5 mm</p>	Analog connector	0.8 N.m	0.1 to 1.5 mm ²	0.1 to 1.5 mm ²	0.1 to 1.5 mm ²
<p>DB124331</p> <p>0 V 24 V</p> <p>7 mm 0.6 x 3.5 mm</p>	Power supply connector	0.8 N.m	0.2 to 1.5 mm ²	0.2 to 1.5 mm ²	0.2 to 1.5 mm ²
<p>DB405141</p> <p>0 V</p> <p>D0 = A- / Rx-, A / Tx- D1 = B- / Rx+, B / Tx+</p> <p>7 mm 0.6 x 3.5 mm</p>	Modbus connector	0.8 N.m	0.25 mm ²	0.25 mm ²	0.25 mm ²
<p>DB405142</p> <p>1 2</p> <p>≤ 50 mm ≤ 20 mm</p>					

PowerTag Acti9 63 A

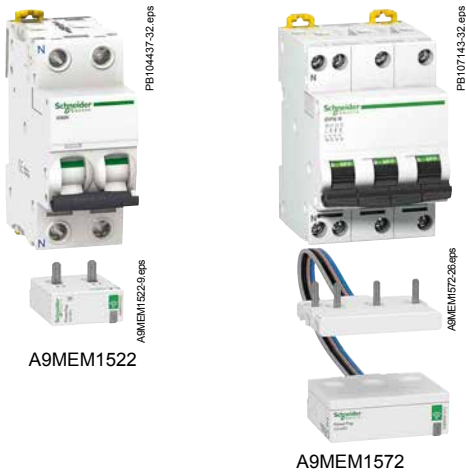

IEC 61557-12 PMD/DD/K55/1

PowerTag is a wireless-communication energy sensor

PowerTag energy sensor is designed specifically for Energy Management, Load Monitoring and Power Availability applications.

With its compact design and innovative concept, PowerTag fits directly on the protective device and as a result has no impact on DIN rail occupancy and switchboard size.

Voltage and current are therefore measured directly at the same point on the circuit to be monitored, providing accurate measurement and relevant information such as voltage loss.

PowerTag energy sensor incorporates every feature required to perform accurate real-time measurements (U, V, I, P and PF) and metering values (Ea). Used together with a concentrator to collect and process the data, it provides circuit monitoring and diagnosis down to load level.

- Wireless-communication technology simplifies switchboard wiring and commissioning operations: no wiring is required for the PowerTag to communicate with the concentrator.
- System scalability: PowerTag energy sensor can be quickly and easily installed in new or existing panels at any time.
- Different designs of the PowerTag energy sensor are available to ensure it fits the protective device on which it is mounted.
- PowerTag Acti9 63 A is compatible with the Acti9 and Multi9 ranges as per the selection guide CA908058.

Functions



PowerTag energy sensor measures the following values in accordance with the IEC 61557-12 standard

- Active energy (class 1), total and partial (kWh), delivered and received.
- Real-time measurement values:
 - phase-to-neutral and phase-to-phase voltages (V),
 - current per phase (A),
 - active power, total and per phase (W),
 - apparent power total (VA),
 - power factor.
- Voltage loss alarms:
 - PowerTag energy sensor sends a "voltage loss" alarm and the current-per-phase value before being de-energized,
 - at "voltage loss", PowerTag adds an overload alarm if the current is higher than the rated current of the associated protective device.

Note: Functions listed above depends on concentrator.

Main associated concentrators (*)

For Commercial & Building applications

Acti9 PowerTag Link	Acti9 PowerTag Link HD	Acti9 Smartlink SI B
		
A9XMWD20 (1)	A9XMWD100	A9XMZA08
(1) Replace Smartlink SI D (A9XMWA20)		

For Small Business applications

Acti9 PowerTag Link C

A9XELC10

(*) Refer to Selection Guide for complete compatibility (CA908058)
Refer to the concentrator catalogs for more information (CA907030, CA907032, CA907035).



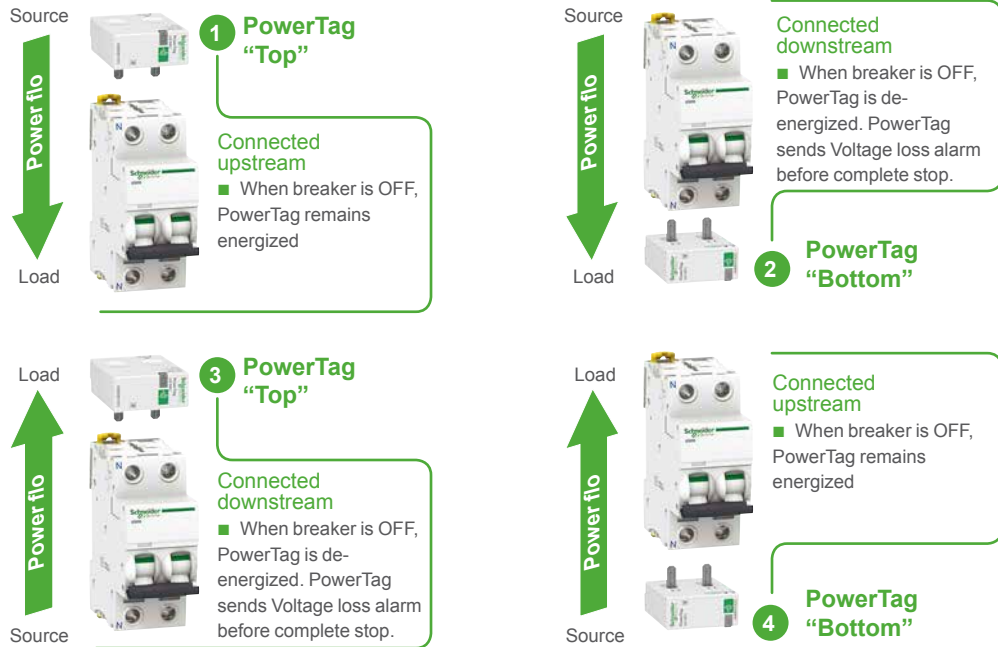

Mounting positions



Note:

- In association with a contactor, a Variable Speed Drive or a motor starter: PowerTag can ONLY be installed UPSTREAM these devices.
- Some PowerTag can be installed either on the TOP or on the BOTTOM of the protective devices.
- Check the possible mounting position as indicated in the "Catalog numbers" chapter.

Connection	Features
Upstream Preferred installation to take full benefit of voltage loss in diagnosing the load	1 ■ Energy management: consumption in kWh 4 ■ Load monitoring: real-time measurements
Downstream Preferred installation to take full benefit of voltage loss in diagnosing the load	2 ■ Energy management: consumption in kWh 3 ■ Load monitoring: real-time measurements ■ Power availability: voltage loss

Energy management and load monitoring

PowerTag Acti9 63 A (cont.)



A9MEM1520

A9MEM1520-1 eps



A9MEM1521

A9MEM1521-10 eps



A9MEM1540

A9MEM1540-10 eps



A9MEM1522

A9MEM1522-10 eps



A9MEM1543

A9MEM1543-10 eps



A9MEM1541

A9MEM1541-10 eps



A9MEM1542

A9MEM1542-10 eps



A9MEM1561

A9MEM1561-19 eps



A9MEM1562

A9MEM1562-21 eps



A9MEM1563

A9MEM1563-21 eps



A9MEM1571

A9MEM1571-22 eps



A9MEM1572

A9MEM1572-26 eps



A9MEM1560

A9MEM1560-17 eps



A9MEM1573

A9MEM1573-21 eps



A9MEM1570

A9MEM1570-21 eps

Catalog numbers

PowerTag A9 M63

PowerTag for Acti9 and Multi9 **Monoconnect** offers: "Single-terminal" circuit breakers, RCDs and switches with **18 mm pitch between phase and neutral**, rating less than or equal to 63 A.



PowerTag A9 M63

Type	Mounting	Short description	Cat. no.
1P+wire	Top or bottom	PowerTag A9 M63 1PW	A9MEM1520
1P+N	Top	PowerTag A9 M63 1PN T	A9MEM1521
	Bottom	PowerTag A9 M63 1PN B	A9MEM1522
3P	Top or bottom	PowerTag A9 M63 3P	A9MEM1540
3P+N	Top	PowerTag A9 M63 3P 230V LL	A9MEM1543 (1)
	Bottom	PowerTag A9 M63 3PN T	A9MEM1541
	Bottom	PowerTag A9 M63 3PN B	A9MEM1542

Designed to fit the following devices: iC60, Reflex iC60, DT60, iLD.

For additional information and the list of Schneider Electric compatible devices and concentrators, refer to the selection guide CA908058.

(1) Not compatible with Acti9 Smartlink SI D (A9XMWA20) and Acti9 Smartlink SI B (A9XMZA08)

PowerTag A9 P63

PowerTag for Acti9 and Multi9 **PhaseNeutral** offers: "Single-terminal" circuit breakers, RCDs and switches at **pitch of 9 mm between phase and neutral**, rating less than or equal to 63 A.



PowerTag A9 P63

Type	Mounting	Short description	Cat. no.
1P+N	Top	PowerTag A9 P63 1PN T	A9MEM1561
1P+N	Bottom	PowerTag A9 P63 1PN B	A9MEM1562
1P+N RCBO	Bottom	PowerTag A9 P63 1PN B for RCBO	A9MEM1563
3P+N	Top	PowerTag A9 P63 3PN T	A9MEM1571
3P+N	Bottom	PowerTag A9 P63 3PN B	A9MEM1572

Designed to fit the following devices: DT40, iDPN, C40, i DPN Vigi.

For additional information and the list of Schneider Electric compatible devices and concentrators, refer to the selection guide CA908058.

PowerTag A9 F63

PowerTag **Flex** for other devices and specific installations, rating less than or equal to 63 A.



PowerTag A9 F63

Type	Mounting	Short description	Cat. no.
1P+N	Top or bottom	PowerTag A9 F63 1PN	A9MEM1560
3P	Top or bottom	PowerTag A9 F63 3P	A9MEM1573 (2)
3P+N	Top or bottom	PowerTag A9 F63 3PN	A9MEM1570

Designed to fit the following devices: Vigi iDT40, Vigi iC40, Vigi iC60, iC60 double terminal, iLD double terminal.

For additional information and the list of Schneider Electric compatible devices and concentrators, refer to the selection guide CA908058.

(2) Not compatible with Acti9 PowerTag Link C (A9XELC10), Acti9 Smartlink SI D (A9XMWA20) and Acti9 Smartlink SI B (A9XMZA08)

PowerTag Acti9 63 A (cont.)



Technical characteristics

Main characteristics

Rated voltage	Un	Phase-to-neutral	230 V AC \pm 20 %
		Phase-to-phase	400 V AC \pm 20 %
		Phase-to-phase (A9MEM1543)	230 V AC \pm 20 %
Frequency			50/60 Hz
Maximum current	I _{max}		63 A
Base current	I _b		10 A
Saturation current			130 A
Maximum consumption		1P+N	\leq 1 VA
		3P/3P+N	\leq 2 VA
Starting current	I _{st}		40 mA

Additional characteristics

Operating temperature			-25°C to +60°C
Storage temperature			-40°C to +85°C
Overvoltage category	As per IEC 61010-1		Cat. III
Measuring category	As per IEC 61010-2-30		Cat. III
Pollution degree			3
Altitude			\leq 2000 m
Degree of protection	Device only		IP20
		IK	05

Radio-frequency communication

ISM band 2.4 GHz			2.4 GHz to 2.4835 GHz
Channels	As per IEEE 802.15.4		11 to 26
Isotropic Radiated Power	Equivalent (EIRP)		0 dBm
Maximum transmission time			< 5 ms
Channel occupancy	Messages sent every		5 seconds minimum

Characteristics of measuring functions

Function		Performance category as per IEC 61557-12	Measuring range
Active power	P	1	9 W to 63 kW
Active energy	E _a	1	Total and partial 0 to 99999999.9 kWh
Current	I	1	2 A to 63 A
Voltage	U	0.5	Un \pm 20 %
Power factor	PFA	1	0 to 1



Connection of PowerTag A9 M63

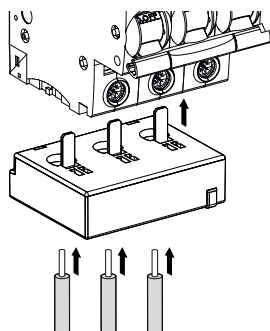

Stripping length	Copper cables					
	Rigid		Flexible		Flexible with ferrule	
18 mm	DB1123545 eps 1.5 to 16 mm ² AWG: 16...6	DB1123544 eps 2 x 1.5 to 2.5 mm ² AWG: 16...14	DB1123550 eps 1.5 to 16 mm ² AWG: 16...6	DB1123505 eps 2 x 1.5 to 2.5 mm ² AWG: 16...14	-	-
18 mm	-	-	-	-	DB1123554 eps 1.5 to 16 mm ² AWG: 16...6	DB1123008 eps 2 x 1.5 to 2.5 mm ² AWG: 16...14

■ Mounting with 18 mm ferrule recommended.

Dimensions (mm)

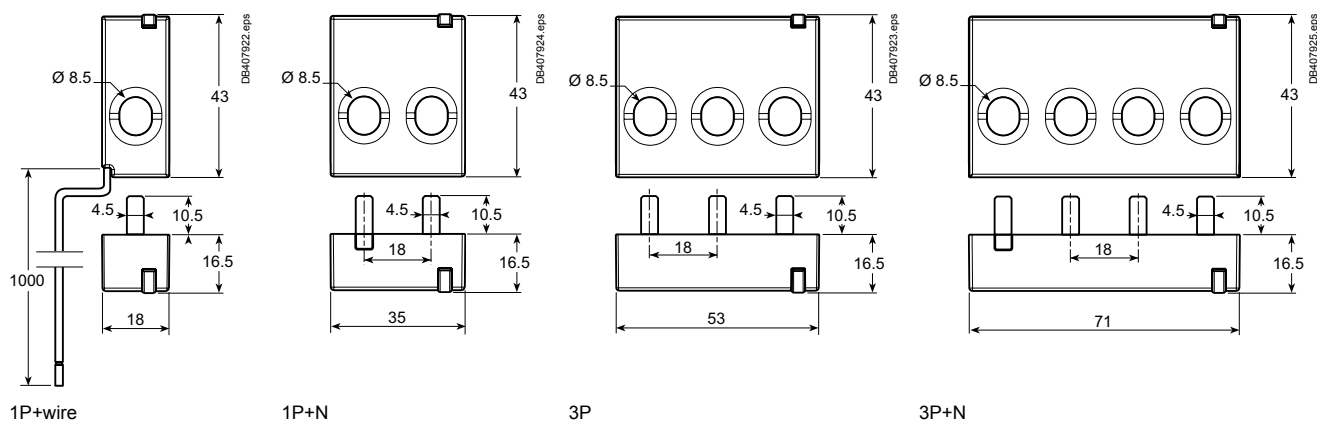

Weight (g)

PowerTag A9 M63	
Type	Weight (g)
1P+wire	16.4
1P+N	17.5
3P	28
3P+N	35



Connection of PowerTag A9 P63

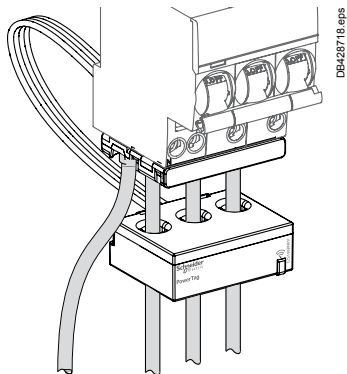

Copper cables					
Rigid		Flexible		Flexible with ferrule	
1.5 to 16 mm ² AWG: 16...6	2 x 1.5 to 2.5 mm ² AWG: 16...14	1.5 to 16 mm ² AWG: 16...6	2 x 1.5 to 2.5 mm ² AWG: 16...14	-	-
-	-	-	-	1.5 to 16 mm ² AWG: 16...6	2 x 1.5 to 2.5 mm ² AWG: 16...14

■ Stripping length: respect the stripping length stated on the device the PowerTag is associated with.

Dimensions (mm)

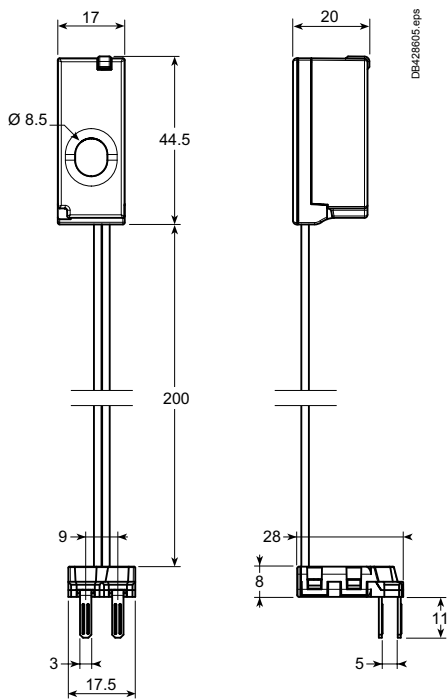

1P+N

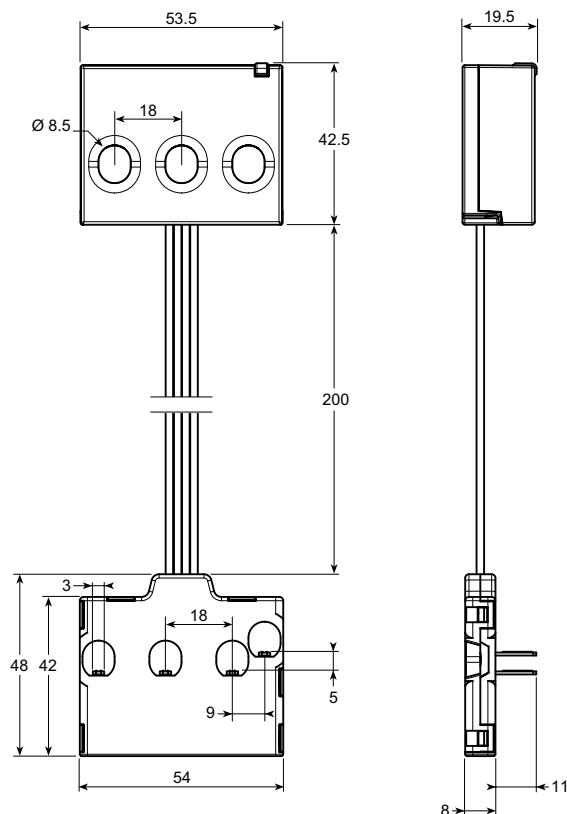

3P+N

Weight (g)

PowerTag A9 P63	
Type	
1P+N	42
3P+N	71



Connection of PowerTag A9 F63

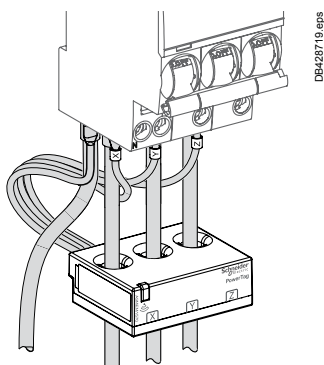

Copper cables					
Rigid		Flexible		Flexible with ferrule	
1.5 to 16 mm ² AWG: 16...6	2 x 1.5 to 2.5 mm ² AWG: 16...14	1.5 to 16 mm ² AWG: 16...6	2 x 1.5 to 2.5 mm ² AWG: 16...14	-	-
-	-	-	-	1.5 to 16 mm ² AWG: 16...6	2 x 1.5 to 2.5 mm ² AWG: 16...14

■ Stripping length: respect the stripping length stated on the device the PowerTag is associated with.

Dimensions (mm)

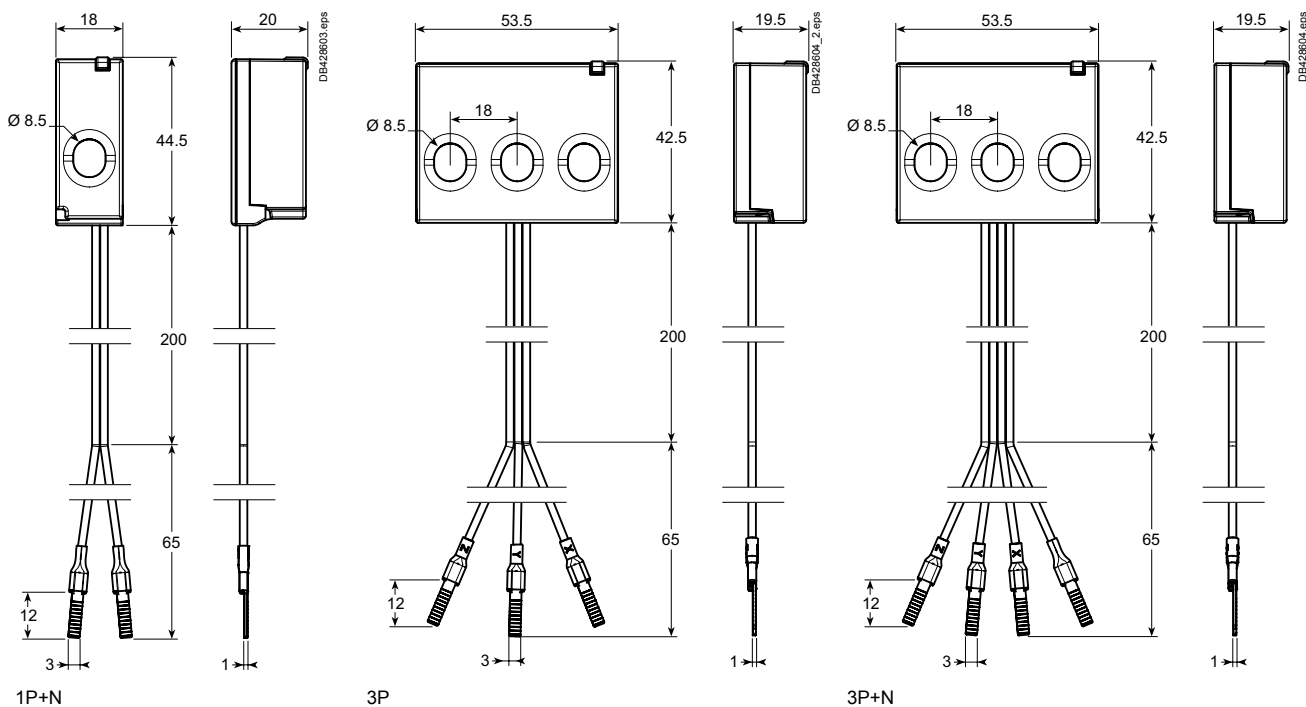

Weight (g)

PowerTag A9 F63	
Type	Weight (g)
1P+N	46
3P	63
3P+N	65

Load control and monitoring

PowerTag Control



PowerTag Control are wireless-communication modules designed specifically for Control and Monitoring applications. They are part of PowerTag System and Wiser System, allowing to turn easily a distribution board into a connected panel.

PowerTag Control is designed to monitor a circuit, notifying wirelessly to the concentrator the information status of a contact (OF, SD, CT or TL position indication...).

Depending on its functionalities, PowerTag Control can operate a load remotely through a contactor, an impulse relay... thanks to wireless control orders from the concentrator.

Refer to the selection guide to select the right module as per the application required.

- Wireless-communication technology simplifies cabling and commissioning operations: no wiring is required for the PowerTag Control modules to communicate with the concentrator.
- System scalability: PowerTag Control modules can be easily installed in new or existing panels at any time with simple commissioning operation.
- PowerTag Control modules are DIN rail mounted.



PowerTag C IO 230V



PowerTag C 2DI 230V



PowerTag C IO 230V



Acti9 PowerTag Link C

Associated concentrators

For Residential applications

Wiser IP Module



EER31800

For Commercial & Building applications

PowerTag Link



A9XMWD20

PowerTag Link HD



A9XMWD100

For Small Business applications

Acti9 PowerTag Link C



A9XELC10

Refer to the concentrators catalog for more information.

Load control and monitoring

PowerTag Control (cont.)



Selection guide

Application	PowerTag C IO 230V		PowerTag C 2DI 230V	
	Control ⁽¹⁾	Monitoring / Back loop ⁽²⁾	Control ⁽¹⁾	Monitoring ⁽²⁾
Digital input 230 V AC	-	1	-	2
Digital output 230 V AC	1	-	-	-
Compatible with	Circuit 2 A Max - 230 V AC: - Contactors 230 V AC - Impulse relays 230 V AC - RCA (cat no A9C7011x) ...	Dry contact 230 V AC: - iACTs - iATLs ...	-	Dry contact 230 V AC: - OF 230 V AC - SD 230 V AC - OF/SD 230 V AC ...
Width in 9-mm modules	2		2	
Catalog numbers	A9XMC1D3		A9XMC2D3	

(1) To operate a circuit remotely (2) To notify a status remotely

Principle diagrams

PowerTag C IO 230V

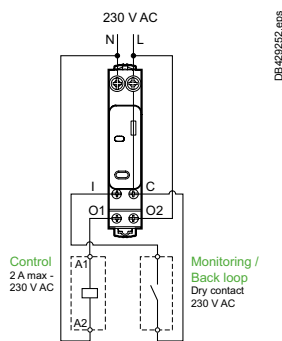

PowerTag C 2DI 230V

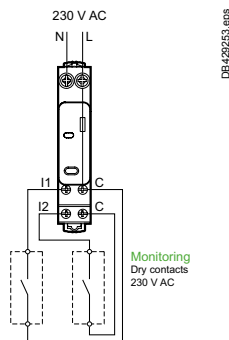

Load control and monitoring

PowerTag Control (cont.)

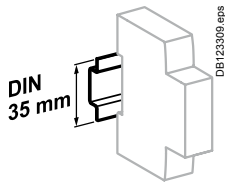

Clip on DIN rail 35 mm.

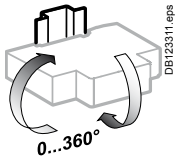

Indifferent position of installation.

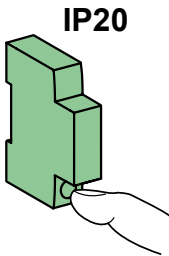

IP20

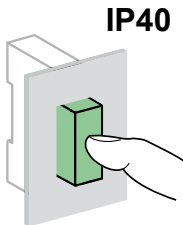

IP40

DB123313.eps

Technical characteristics

Main characteristics

Power supply	230 V AC \pm 20%	
Frequency	50/60 Hz	
Maximum consumption	IO	\leq 2 VA
	2DI	\leq 3 VA
Operating temperature	-25°C to +60°C	
Storage temperature	-40°C to +85°C	
Relative humidity (60068-2-78)	93 % at 40°C	
Overvoltage category	As per IEC 61010-1	Cat. III
Altitude	\leq 2000 m	
Pollution degree	3	
Degree of protection according to IEC 60529	Front face	IP40
	Casing	IP20
	IK	05

Characteristics of inputs and outputs

Digital input

Type	230 V AC, dry contact
------	-----------------------

Digital output

Type	230 V AC, dry contact
Relay type	Normally open or normally closed ⁽³⁾
Applicable voltage on output	230 V AC \pm 20%
Minimum/maximum current on output	10 mA / 2 A
Type of output order	Pulse or latch ⁽³⁾
Pulse length in control mode with impulse relay	Nominal: 300 ms

Radio-frequency communication

ISM band 2.4 GHz	2.4 GHz to 2.4835 GHz	
Channels	As per IEEE 802.15.4	11 to 26
Isotropic Radiated Power	Equivalent (EIRP)	0 dBm
Channel occupancy	Messages sent	<ul style="list-style-type: none"> ■ On event ■ Periodically (5s nominal)

(3) Setting adjustable

Dimensions (mm)

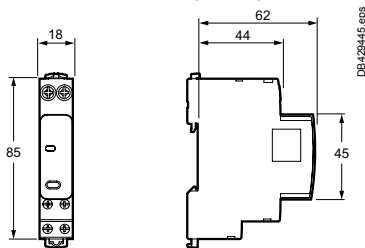

Weight (g)

PowerTag C

PowerTag C IO 230 V	80
PowerTag C 2DI 230 V	75

Connection

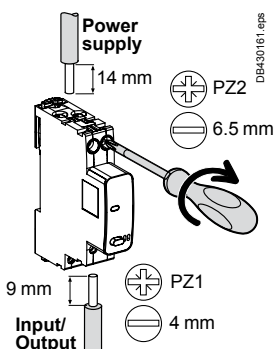

Terminals	Tightening torque	Copper cables		
		Rigid	Flexible	Flexible with ferrule
Power supply (Top)	2 N.m	1 to 16 mm ² (AWG: 18...6)	0.5 to 10 mm ² (AWG: 21...8)	-
Input/Output (Bottom)	1 N.m	1x: 1 to 6 mm ² (AWG: 18...10) 2x: 1.5 to 2.5 mm ² (AWG: 16...14)	1x: 0.5 to 4 mm ² (AWG: 21...12) 2x: 1.5 to 2.5 mm ² (AWG: 16...14)	1x: 0.5 to 4 mm ² (AWG: 21...12) 2x: -

Load control and monitoring

PowerTag Control (cont.)



PowerTag C IO module

- Compatible with horizontal comb busbars 9 mm modules
- Automatic cable guiding in the correct position: terminals with guard

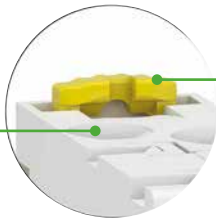

- Assembly and disassembly by operating toggle latches at the top and bottom of the products

- Status LED**
- Provide information about PowerTag C status

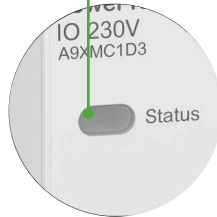

- Insulated terminals IP20



- Logo**
- Wireless communication device

- Push button**
- Local output control
 - Decommissioning

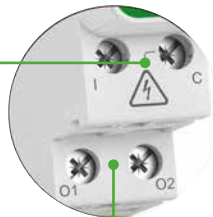

- Monitoring / Back loop circuit**
- "I" digital input terminal
 - "C" common powered terminal 230 V AC

- Control circuit**
- Logical output relay
 - "O" output terminals 230 V AC - 2 A max.

Load control and monitoring PowerTag Control (cont.)



PowerTag C 2DI module

- Compatible with horizontal comb busbars 9 mm modules
- Automatic cable guiding in the correct position: terminals with guard

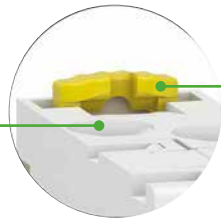

DB430243.eps

- Assembly and disassembly by operating toggle latches at the top and bottom of the products

Status LED

- Provide information about PowerTag C status

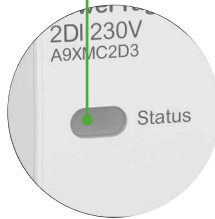

2DI 230V
A9XMC2D3

Status

DB430244.eps

- Insulated terminals IP20



A9XMC2D3_image2.65.eps

Logo

- Wireless communication device



DB430245.eps

Flush mounted push button

- Decommissioning



DB430242.eps

Monitoring circuits

- "I" digital input terminals
- "C" common powered terminals 230 V AC

PowerTag Ambient for Temperature



PowerTag Ambient for Temperature



ZBRA1 relay antenna

IEC 60950, EN 61000-6-1, EN 61000-6-3, EN 61326-1, EN 62311:2007, ETSI EN 301 489-1, ETSI EN 301 489-17, ETSI EN 300 328

As per the above standard: **PowerTag Ambient for Temperature are wireless-communication modules** designed specifically to collect temperatures measures for Monitoring applications. They are part of PowerTag System, thanks to wireless-communication to the PowerTag Link C concentrator.

The PowerTag Ambient for Temperature is to be placed directly in the targeted location (cold room/ fridge...) to monitor. The sensor transmits information to the concentrator every 2 minutes. The sensor also stores 1 measure per hour in order to enable the generation of HACCP compliant automated temperature reports.

- Wireless-communication technology simplifies cabling and commissioning operations: no wiring is required for the PowerTag Ambient for Temperature modules to communicate with the concentrator, up to 100 m open field.
- System scalability: PowerTag Ambient for Temperature modules can be easily installed at any time with simple commissioning operation.
- PowerTag Ambient for Temperature modules work on battery and can be installed with double-side tape, clamp or screw.
- Depending on the setup of the electrical panel where the PowerTag Link C is located, the quality of the signal can be improved by a repeater.

Accessory

- Relay antenna (signal repeater)

Catalog number

PowerTag Ambient for Temperature	
PowerTag Ambient for Temperature (set of 4)	A9XST114
Accessory	
Relay antenna, AC/DC, 5m cable output	ZBRA1

Associated concentrator

For Small Business applications

Acti9 PowerTag Link C	
A9XELC10	

Refer to the concentrator catalog for more information.



PowerTag Ambient for Temperature

Acti9 PowerTag Link C

A9XELC10

PowerTag Ambient for Temperature (cont.)



Technical characteristics

Main characteristics		
Measurement range	-30°C to +55°C ± 1°C	
Battery duration	2 years	
Operating temperature	-30°C to +55°C	
Storage temperature	-30°C to +55°C	
Operating/storage humidity	0...95 % Relative Humidity	
Degree of protection	IP65	
Radio-frequency communication		
Operating frequency	2.405 GHz	
Maximum output power	4 dBm	
Channel occupancy	Messages sent	every 2 minutes

Dimensions (mm)

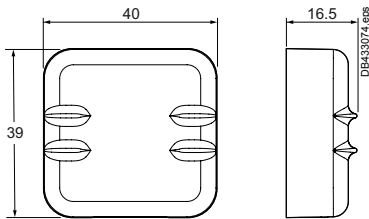

Weight (g)

PowerTag Ambient for Temperature (set of 4)	60
---	----

PowerTag

Selection guide for product compatibility*
(Compatibility for terminal not equipped with comb busbar)

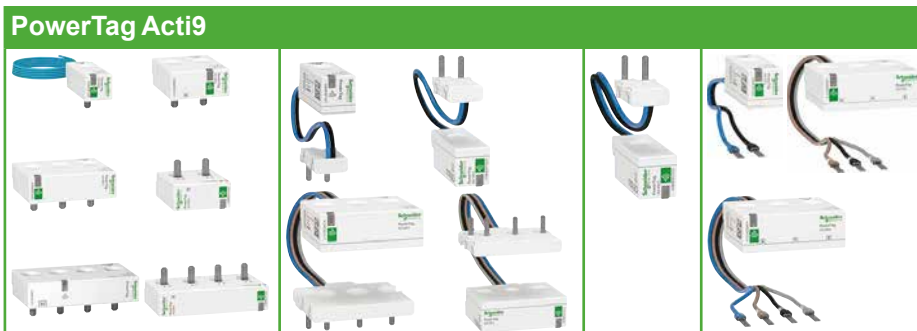

Products (AC network)	Mounting position	A9 M63	A9 P63	A9 P63 RCBO	A9 F63
Acti9/Multi9 Circuit breakers					
iC60/iK60/DT60	Top	☑	-	-	-
	Bottom	☑	-	-	-
iC60 (double terminal)	Top	-	-	-	☑
	Bottom	-	-	-	☑
iC40	Top	-	☑	-	-
	Bottom	-	☑	-	-
DT40/iDPN/C40	Top	-	☑	-	-
	Bottom	-	☑	-	-
C120 ≤ 63 A NG125 ≤ 63 A	Top	-	-	-	☑ (1)
	Bottom	-	-	-	☑ (1)
iC65N-K (China) iC65 (China)	Top	☑	-	-	-
	Bottom	☑	-	-	-
Reflex iC60	Top	☑	-	-	-
	Bottom	☑	-	-	-
C32/C45/C60/C65/K60/T60/ C60-OEM	Top	☑	-	-	-
	Bottom	☑	-	-	-
Circuit breakers equipped with Vigi module					
iC60 with Vigi module	Top	☑ (CB)	-	-	-
	Bottom	-	-	-	☑ (Vigi) (1)
iC40 with Vigi iCG40	Top CB	-	☑ (CB)	-	-
	Top (Vigi)	-	☑ (Vigi 1P+N) (2)	-	-
	Bottom (Vigi)	-	-	-	☑ (Vigi 3P+N)
iC40 with "outgoer" Vigi module	Top	-	☑ (CB)	-	-
	Bottom	-	-	-	☑ (Vigi)
DT40/DPN/C40 with "group feeder" Vigi module	Top CB	-	☑ (CB)	-	-
	Top Vigi	-	☑ (Vigi 1P+N)	-	☑ (Vigi 3P+N)
DT40/DPN/C40 with "outgoer" Vigi module	Top	-	☑ (CB)	-	-
	Bottom	-	-	-	☑ (Vigi)
DT60 with Vigi TG60	Top CB	☑ (CB) only A9MEM1541	-	-	-
	Top Vigi	-	-	-	☑ (Vigi) (1)

(1) You may need to change the voltage measurement cable terminals of the PowerTag F63 by other cable ends (wire AWG22/0.33 mm²) for a more suitable connection to this product.

(2) Product usually associated with a comb busbar

(*) Refer to the product catalogue for technical characteristics

PowerTag

Selection guide for product compatibility* (cont.)
(Compatibility for terminal not equipped with comb busbar)

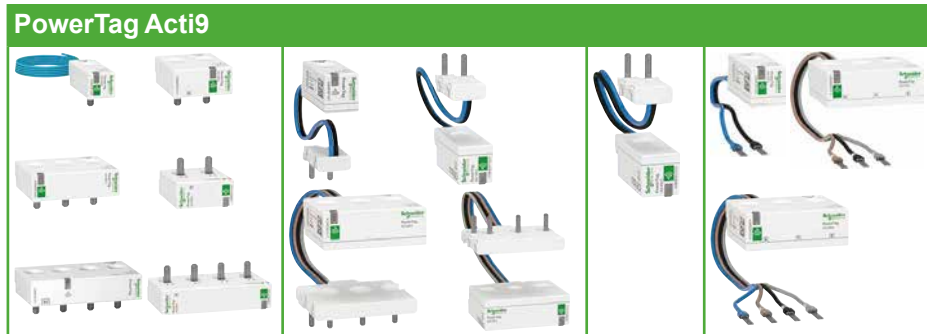

Products (AC network)	Mounting position	A9 M63	A9 P63	A9 P63 RCBO	A9 F63
Acti9/Multi9					
Residual current devices					
iID/iID K	Top	☑	-	-	-
	Bottom	☑	-	-	-
iID (double terminal)	Top	-	-	-	☑
	Bottom	-	-	-	☑
iID40	Top	-	☑ 1P+N (2)	-	☑ 3P+N (2)
	Bottom	☑	-	-	-
iDPN Vigi "outgoer" 1P+N	Top	-	☑	-	-
	Bottom	-	☑	-	-
iC60 RCBO	Top	☑	-	-	-
	Bottom	☑	-	-	-
iCV40 "outgoer" 1P+N	Top	-	☑	-	-
	Bottom	-	☑	-	-
iCV40 "outgoer" 3P+N	Top	-	☑	-	-
	Bottom	-	-	-	☑
DPN Vigi/DT40 Vigi/C40 Vigi "outgoer" 1P+N	Top	-	☑	-	-
	Bottom	-	☑	-	-
DPN Vigi/DT40 Vigi/C40 Vigi/ iDPN Vigi "outgoer" 3P+N	Top	-	☑	-	-
	Bottom	-	-	-	☑
DPN Vigi K	Top	-	-	-	☑ (1)
	Bottom	-	-	-	☑ (1)
iDc/ITG40/C40	Top Left	-	☑	-	-
	Top Right	-	☑	-	-
DCP Vigi	Top	☑	-	-	-
	Bottom	☑	-	-	-
C60H RCBO (Multi9)	Top	NA (fishbone)	-	-	-
	Bottom	-	-	☑	-
ID ≤ 63 A/ID K biconnect/ ID Type B ≤ 63 A	Top	☑	-	-	-
	Bottom	☑	-	-	-
RED/REDS/REDTest	Top	-	-	-	☑ (1)
	Bottom	-	-	-	☑ (1)

(1) You may need to change the voltage measurement cable terminals of the PowerTag F63 by other cable ends (wire AWG22/0.33 mm²) for a more suitable connection to this product.
(2) Product usually associated with a comb busbar

(*) Refer to the product catalogue for technical characteristics

PowerTag

Selection guide for product compatibility* (cont.)
(Compatibility for terminal not equipped with comb busbar)







Products (AC network)	Mounting position	A9 M63	A9 P63	A9 P63 RCBO	A9 F63
Acti9/Multi9 Switches					
iSW ≤ 63 A	Top	✓	-	-	-
	Bottom	✓	-	-	-
iSW-NA ≤ 63 A	Top	✓	-	-	-
	Bottom	✓	-	-	-
iSW 20/32 A	Top	-	-	-	✓
	Bottom	-	-	-	✓
i-NA ≤ 63 A	Top	✓	-	-	-
	Bottom	✓	-	-	-
NG125 NA ≤ 63 A	Top	-	-	-	✓ (1)
	Bottom	-	-	-	✓ (1)
Fuse disconnectors					
STI	Top	-	✓	-	-
	Bottom	-	✓	-	-
SBI 14x51/SBI 22x58 ≤ 63 A	Top	-	-	-	✓ (1)
	Bottom	-	-	-	✓ (1)
D01/D02	Top	-	-	-	✓ (1)
	Bottom	-	-	-	✓ (1)
TeSys					
Circuit breakers					
GV2	Top	-	-	-	✓ (1) (2)
	Bottom	-	-	-	✓ (1) (2)
GV3 ≤ 63 A	Top	-	-	-	✓ (1) (2)
	Bottom	-	-	-	✓ (1) (2)
Contactors					
LC1D ≤ 63 A	Top	-	-	-	✓ Upstream only (1)
	Bottom	-	-	-	-

(1) You may need to change the voltage measurement cable terminals of the PowerTag F63 by other cable ends (wire AWG22/0.33 mm²) for a more suitable connection to this product.
(2) PowerTag Energy sensors withstand motor starting in-rush currents. Environmental mission profile : Buildings as per 60721-3-3.

(*) Refer to the product catalogue for technical characteristics

PowerTag

Selection guide for product compatibility* (cont.)

			PowerTag NSX			
						
Products (AC network)		Mounting position	250 3P	250 3P+N	630 3P	630 3P+N
Compact						
Circuit breakers						
NSX100/160/250 B/F/N/H/S/L/R Fixed	3P	Bottom	☑	-	-	-
	4P	Bottom	-	☑	-	-
NSX400/630 F/N/H/S/L/R Fixed	3P	Bottom	-	-	☑	-
	4P	Bottom	-	-	-	☑
NSX100/160/250 B/F/N/H/S/L/R Plug-In (mounted on the base)	3P	Top / Bottom	☑	-	-	-
	4P	Top / Bottom	-	☑ (3)	-	-
NSX400/630 F/N/H/S/L/R Plug-In (mounted on the base)	3P	Top / Bottom	-	-	☑ (4)	-
	4P	Top / Bottom	-	-	-	☑ (3) (4)
NS100/160/250 N/ SX/H/L Fixed	3P	Bottom	☑	-	-	-
	4P	Bottom	-	☑	-	-
NS400/630 N/H/L Fixed	3P	Bottom	-	-	☑	-
	4P	Bottom	-	-	-	☑
NS100/160/250 N/ SX/H/L Plug-In (mounted on the base)	3P	Top / Bottom	☑	-	-	-
	4P	Top / Bottom	-	☑ (3)	-	-
NS400/630 N/H/L Plug-In (mounted on the base)	3P	Top / Bottom	-	-	☑ (4)	-
	4P	Top / Bottom	-	-	-	☑ (3) (4)
Circuit breakers equipped with Vigi block						
NSX100/160/250 B/F/N/H/S/L/R Fixed	3P	Bottom	☑	-	-	-
	4P	Bottom	-	☑	-	-
NSX400/630 F/N/H/S/L/R Fixed	3P	Bottom	-	-	☑	-
	4P	Bottom	-	-	-	☑
NSX100/160/250 B/F/N/H/S/L/R Plug-In (mounted on the base)	3P	Top	☑	-	-	-
	3P	Top	-	-	☑ (4)	-
Switches						
INS250/INV - 100/160/200/250	3P	Bottom	-	☑	-	-
	4P	Top / Bottom	-	☑ (3)	-	-
INS/INV - 320/400/500/630	3P	Bottom	-	-	-	☑
	4P	Top / Bottom	-	-	-	☑ (3)









(3) neutral on the right when mounted on top side

(4) when plate mounted, need to add a 4 mm intercalary under the PowerTag module (see Compact NSX catalog)

(*): Refer to the product catalogue for technical characteristics

PowerTag

Selection guide for concentrator compatibility*

Concentrators						
						
	Acti9 PowerTag Link C A9XELC10	Acti9 Smartlink SI B A9XMZA08	Acti9 Smartlink SI D A9XMWA20	Acti9 PowerTag Link A9XMWD20	Acti9 PowerTag Link HD A9XMWD100	
PowerTag Acti9 M63						
	A9MEM1520	<input checked="" type="checkbox"/>	<input checked="" type="checkbox"/>	<input checked="" type="checkbox"/>	<input checked="" type="checkbox"/>	<input checked="" type="checkbox"/>
	A9MEM1521	<input checked="" type="checkbox"/>	<input checked="" type="checkbox"/>	<input checked="" type="checkbox"/>	<input checked="" type="checkbox"/>	<input checked="" type="checkbox"/>
	A9MEM1522	<input checked="" type="checkbox"/>	<input checked="" type="checkbox"/>	<input checked="" type="checkbox"/>	<input checked="" type="checkbox"/>	<input checked="" type="checkbox"/>
	A9MEM1540	<input checked="" type="checkbox"/>	<input checked="" type="checkbox"/>	<input checked="" type="checkbox"/>	<input checked="" type="checkbox"/>	<input checked="" type="checkbox"/>
	A9MEM1541	<input checked="" type="checkbox"/>	<input checked="" type="checkbox"/>	<input checked="" type="checkbox"/>	<input checked="" type="checkbox"/>	<input checked="" type="checkbox"/>
	A9MEM1542	<input checked="" type="checkbox"/>	<input checked="" type="checkbox"/>	<input checked="" type="checkbox"/>	<input checked="" type="checkbox"/>	<input checked="" type="checkbox"/>
	A9MEM1543	<input checked="" type="checkbox"/>	-	-	<input checked="" type="checkbox"/>	<input checked="" type="checkbox"/>
PowerTag Acti9 P63						
	A9MEM1561	<input checked="" type="checkbox"/>	<input checked="" type="checkbox"/>	<input checked="" type="checkbox"/>	<input checked="" type="checkbox"/>	<input checked="" type="checkbox"/>
	A9MEM1562	<input checked="" type="checkbox"/>	<input checked="" type="checkbox"/>	<input checked="" type="checkbox"/>	<input checked="" type="checkbox"/>	<input checked="" type="checkbox"/>
	A9MEM1563	<input checked="" type="checkbox"/>	<input checked="" type="checkbox"/>	<input checked="" type="checkbox"/>	<input checked="" type="checkbox"/>	<input checked="" type="checkbox"/>
	A9MEM1571	<input checked="" type="checkbox"/>	<input checked="" type="checkbox"/>	<input checked="" type="checkbox"/>	<input checked="" type="checkbox"/>	<input checked="" type="checkbox"/>
	A9MEM1572	<input checked="" type="checkbox"/>	<input checked="" type="checkbox"/>	<input checked="" type="checkbox"/>	<input checked="" type="checkbox"/>	<input checked="" type="checkbox"/>
PowerTag Acti9 F63						
	A9MEM1560	<input checked="" type="checkbox"/>	<input checked="" type="checkbox"/>	<input checked="" type="checkbox"/>	<input checked="" type="checkbox"/>	<input checked="" type="checkbox"/>
	A9MEM1573	-	-	-	<input checked="" type="checkbox"/>	<input checked="" type="checkbox"/>
	A9MEM1570	<input checked="" type="checkbox"/>	<input checked="" type="checkbox"/>	<input checked="" type="checkbox"/>	<input checked="" type="checkbox"/>	<input checked="" type="checkbox"/>
PowerTag NSX						
	LV434020	<input checked="" type="checkbox"/>	<input checked="" type="checkbox"/>	<input checked="" type="checkbox"/>	<input checked="" type="checkbox"/>	<input checked="" type="checkbox"/>
	LV434021	<input checked="" type="checkbox"/>	<input checked="" type="checkbox"/>	<input checked="" type="checkbox"/>	<input checked="" type="checkbox"/>	<input checked="" type="checkbox"/>
	LV434022	<input checked="" type="checkbox"/>	<input checked="" type="checkbox"/>	<input checked="" type="checkbox"/>	<input checked="" type="checkbox"/>	<input checked="" type="checkbox"/>
	LV434023	<input checked="" type="checkbox"/>	<input checked="" type="checkbox"/>	<input checked="" type="checkbox"/>	<input checked="" type="checkbox"/>	<input checked="" type="checkbox"/>

(*) Refer to the product catalogue for technical characteristics

Protection

Circuit protection / Earth leakage protection

Electrical auxiliaries for iC60, iID, iC40, iCV40, iID40, iSW-NA

- The electrical auxiliaries are combined with iC60, iC40, iC40 XA, iCV40, iCV40 XA, iDPN Vigi circuit breakers, iID, iID40 residual current circuit breakers, remote tripping switch disconnecter iSW-NA; they enable tripping or remote indication of their position (open/closed/tripped) upon a fault.
- They are fastened by clips (without tools) to the left side of the breaker.
- The iOF/SD+OF auxiliary is a 2-in-1 product: via a mechanical selector switch, it provides two contacts, OF+SD or OF+OF.
- The iOF+SD24 auxiliary can report open/closed (OF) status information and intentional or fault tripping of the associated device (SD) to the Acti9 Smartlink or a programmable logic controller via the Ti24 interface (24 V DC).

Tripping auxiliaries:

IEC/EN 60947-1

- iMN: undervoltage release
- iMNs: delayed undervoltage release
- iMNx: undervoltage release, independant from supply voltage
- iMX: shunt release
- iMX+OF: shunt release with open/close contact.

EN 50550

- iMSU: overvoltage release.

Indication auxiliaries:

IEC/EN 60947-5-1

- iOF: open/close contact
- iSD: fault indicating contact
- iOF/SD+OF: open/close contact and switchable OF or SD contact
- iOF+SD24: open/close contact OF and default indicating contact SD with Ti24 interface.

IEC/EN 60947-5-4

- iOF+SD24: open/close contact OF and default indicating contact SD with Ti24 interface.

DB404939



DB404940

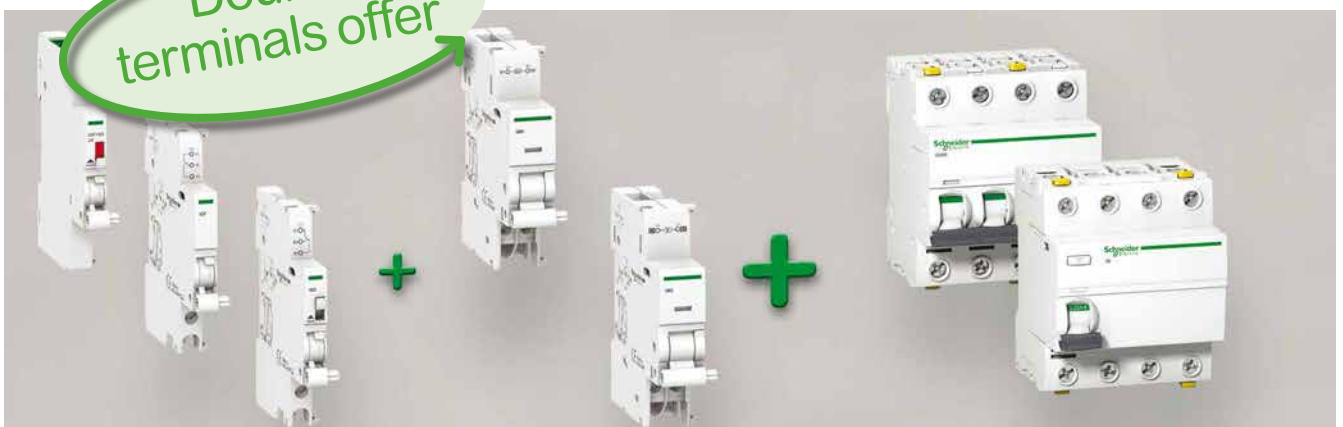

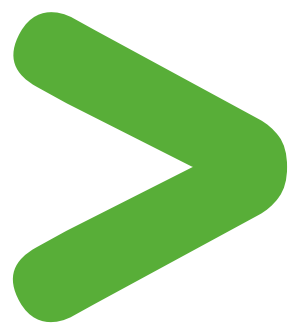



Protection

Circuit protection / Earth leakage protection

Electrical auxiliaries for iC60, iID, iC40, iCV40, iID40, iSW-NA (cont.)

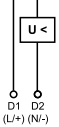
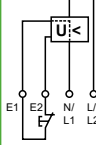
		Tripping							
Auxiliaries		iMN		iMNs		iMNx			
Type		Undervoltage release							
		Instantaneous		Delayed		Independent of the supply voltage			
									
Function		<ul style="list-style-type: none"> Trips the device with which it is combined when its input voltage decreases (between 70 % and 35 % Un). Prevents device closing again until its input voltage is restored 		<ul style="list-style-type: none"> Not tripping on transient voltage dip (up to 0.2 s) 		<ul style="list-style-type: none"> Tripping of the associated device by opening of the control circuit (e.g. push-button, dry contact) A drop in the supply voltage does not trip the associated device A locking push-button control allows the circuit protected (e.g. machine control) to be placed in safety configuration 			
Wiring diagrams									
Use		<ul style="list-style-type: none"> Emergency stoppage by normally closed push button Improve the safety of power supply circuits for several machines by preventing "uncontrolled" restarting 				<ul style="list-style-type: none"> Emergency stoppage with fail-safe principle Insensitive to control circuit voltage variation to increase service continuity Important: Before any servicing operation switch off the mains power supply (voltage presence at terminals E1/E2) 			
Catalogue numbers		A9A26960	A9A27108	A9A26961	A9A26959	A9A26963	A9A26969	A9A26971	
iC60, iID, iID40, iDPN Vigi, iSW-NA		■	■	■	■	■	■	■	
iC40, iCV40		■	■	■	■	■	■	■	
iC40 XA, iCV40 XA		■	■	■	■	■	■	■	
iC60, iID double terminals		■	■	■	■	■	■	■	
iC60 RCBO, iKQE RCBO		■	■	■	■	■	■	■	
Technical specification		220...240 V AC		24 V AC	48 V AC	115 V AC	220...240 V AC		380...415 V AC
Rated voltage (Ue)		-		24 V DC	48 V CC	-	-		-
Standardised operating and non-response to voltage times (Ua)*		-		-	-	-	-		-
Maximum operating time		-		-	-	-	-		-
Minimum non-response time		-		-	-	-	-		-
Operating frequency		50/60 Hz			400 Hz	50/60 Hz	50/60 Hz		
Red mechanical indicator		On front face				On front face		On front face	
Test function		-				-		-	
Width in 9 mm modules		2				2		2	
Operating current		-				-		-	
Number of contacts		-				-		-	
Operating temperature		-35...+70°C				-35...+70°C		-35...+70°C	
Storage temperature		-40...+85°C				-40...+85°C		-40...+85°C	



*(Ua)

Voltages measured between the phase and the neutral conductor, at which the IMSU device must control the associated protective device.

Protection

Circuit protection / Earth leakage protection



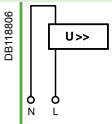
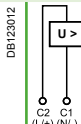
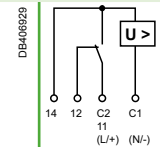



Electrical auxiliaries for iC60, iID, iC40, iCV40, iID40, iSW-NA (cont.)

iMSU						iMX			iMX+OF		
Overvoltage release						Shunt release					
						With Open/Close auxiliary contact					
											
<ul style="list-style-type: none"> Switches off the power supply by opening the breaker with which it is combined, in the event that the phase/neutral voltage is exceeded (loss of neutral). For a four-phase network, use three iMSU tripping auxiliaries. 						<ul style="list-style-type: none"> Trips the associated device when it is powered on 					
						<ul style="list-style-type: none"> Includes an open/close contact (OF) to indicate the "open" or "closed" position of the device 					
											
<ul style="list-style-type: none"> Protection of equipment against overvoltages on the electrical network (neutral conductor break) Voltage monitoring between phase and neutral conductors 						<ul style="list-style-type: none"> Emergency stoppage by normally open push button 			<ul style="list-style-type: none"> Emergency stoppage by normally open push button Remote indication of the position of the associated device 		
A9A26500						A9A26476	A9A26477	A9A26478	A9A26946	A9A26947	A9A26948
■						■	■	■	■	■	■
■						■	■	■	■	■	■
■						■	■	■	■	■	■
■						■	■	■	■	■	■
■						■	■	■	■	■	■
■						■	■	■	■	■	■
230 V AC						100...415 V AC	48 V AC	12...24 V AC	100...415 V AC	48 V AC	12...24 V AC
-						110...130 V DC	48 V DC	12...24 V DC	110...130 V DC	48 V DC	12...24 V DC
255 V AC		275 V AC	300 V AC	350 V AC	400 V AC	-	-	-	-	-	-
No tripping		15 s	5 s	0.75 s	0.20 s	-	-	-	-	-	-
		3 s	1 s	0.25 s	0.07 s	-	-	-	-	-	-
50/60 Hz						50/60 Hz			50/60 Hz		
On front face						On front face			On front face		
-						-			-		
2						2			2		
-						-			10 mA mini, 6 A maxi		
									≤ 24 V DC 6 A		
									48 V DC 2 A		
									≤ 130 V DC 1 A		
									≤ 240 V AC 6 A		
									415 V AC 3 A		
									1 NO/NC		
-35...+70°C						-35...+70°C			-35...+70°C		
-40...+85°C						-40...+85°C			-40...+85°C		

Protection

Circuit protection / Earth leakage protection

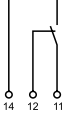
Electrical auxiliaries for iC60, iID, iC40, iCV40, iID40, iSW-NA (cont.)

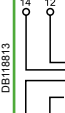
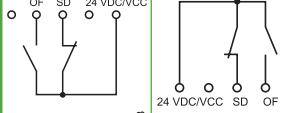
		Indication			
Auxiliaries	iOF	iSD	iOF/SD+OF	iOF+SD24	
Type	Open/close auxiliary contact	Fault indicating contact	Double open/close or fault indicating contact	Double open/close and fault indicating contact	
					
Function	<ul style="list-style-type: none"> Changeover contact indicates "open" or "closed" position of the device 	<ul style="list-style-type: none"> Changeover contact indicates position of the device; upon: <ul style="list-style-type: none"> electrical fault action on tripping auxiliary Same indication as VISI-TRIP 	<ul style="list-style-type: none"> The iOF/SD+OF auxiliary is a 2-in-1 product: via a mechanical selector switch, it provides two contacts, OF+SD or OF+OF 	<ul style="list-style-type: none"> 2 contacts (1 NO + 1 NC) can report the signalling information of the associated device to the Acti9 Smartlink or a programmable logic controller: <ul style="list-style-type: none"> electrical fault actuation of the tripping auxiliary "Open" or "Closed" position of the associated device 	
Wiring diagrams					
Use	<ul style="list-style-type: none"> Remote indication of the position of the associated device 	<ul style="list-style-type: none"> Remote indication of tripping upon a fault of the associated device 	<ul style="list-style-type: none"> Remote indication of position and/or tripping upon a fault of the associated device 	<ul style="list-style-type: none"> Remote indication of position and tripping upon a fault of the associated device 	
Catalogue numbers	A9A26924 A9A26869	A9A26927 A9A26855	A9A26929	A9A26897 A9A26898	
iC60, iID, iID40, iDPN Vigi, iSW-NA	■ -	■ -	■	■ ■	
iC40, iCV40	■ -	■ -	■ if no comb busbar	■ ■	
iC40 XA, iCV40 XA	■ -	■ -	-	- ■	
iC60, iID double terminals	- ■	- ■	■	■ -	
iC60 RCBO, iKQE RCBO	■ -	■ -	-	- -	
Technical specification					
Rated voltage (Ue)	24...415 V AC	24...415 V AC	24...415 V AC	-	
	24...130 V DC	24...130 V DC	24...130 V DC	24 V DC	
Operating frequency	50/60 Hz	50/60 Hz	50/60 Hz	-	
Red mechanical indicator	-	On front face	On front face	On front face	
Test function	On toggle	On toggle	On toggle	On toggle	
Width in 9 mm modules	1	1	1	1	
Operating current	10 mA mini, 6 A maxi			2 mA mini, 100 mA maxi	
	24 V DC 6 A				
	48 V DC 2 A				
	60 V DC 1,5 A				
	130 V DC 1 A				
	24...240 V AC 6 A				
415 V AC 3 A					
Number of contacts	1 NO/NC	1 NO/NC	1 NO/NC + 1 NO/NC	1 NO/NC	
Operating temperature	-35...+70°C	-35...+70°C	-35...+70°C	-25...+70°C	
Storage temperature	-40...+85°C	-40...+85°C	-40...+85°C	-40...+85°C	

Electrical auxiliaries for iC60, iID, iC40, iCV40, iID40, iSW-NA (cont.)

Connection

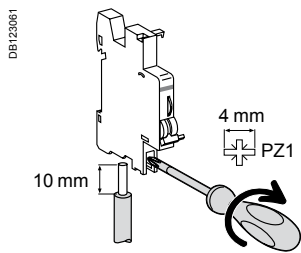

Type	Tightening torque	Copper cables		Multi-cables	
		Rigid	Flexible	Rigid	Cables with ferrule
Indication auxiliaries	1 N.m	1 to 4 mm ²	0.5 to 2,5 mm ²	2 x 2.5 mm ²	2 x 1.5 mm ²
Tripping auxiliaries	1 N.m	1 to 6 mm ²	0.5 to 4 mm ²	2 x 2.5 mm ²	2 x 2.5 mm ²

Ti24 connector connection

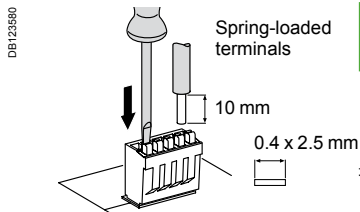

Type	Catalogue numbers	Copper cables	
		Rigid	Flexible
Ti24 interface	A9XC2412	1 x 0.5 to 1.5 mm ²	1 x 0.5 to 1.5 mm ²

Ti24 prefabricated cables connection

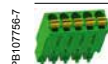
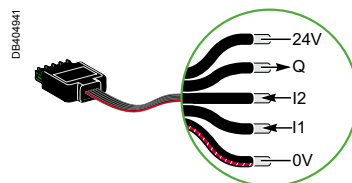

Type	Catalogue numbers	Length
Connection for Acti9 Smartlink		
6 prefabricated	A9XCAS06	100 mm
	A9XCAM06	160 mm
	A9XCAH06	450 mm
	A9XCAL06	870 mm
Connection for PLC type terminals		
6 long prefabricated on a single side	A9XCAU06	870 mm
1 long prefabricated on a single side	A9XCAC01	4000 mm
12 connectors, 5-pins (Ti24)	A9XC2412	-

Protection

Circuit protection / Earth leakage protection

Electrical auxiliaries for iC60, iID, iC40, iCV40, iID40, iSW-NA (cont.)

Technical data

Weight (g)

Electrical auxiliaries	
Type	
iMN	69
iMNs	72
iMNx	79
iMSU	68
iMX	64
iMX+OF	68
iOF	32
iSD	33
iOF/SD+OF	43
iOF+SD24	25

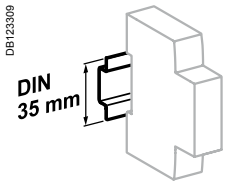

Clip on DIN rail 35 mm.

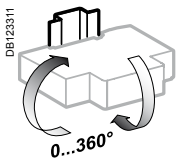

Indifferent position of installation.

Dimensions (mm)

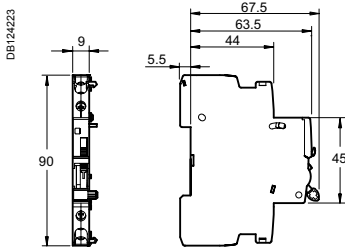

iOF/SD+OF

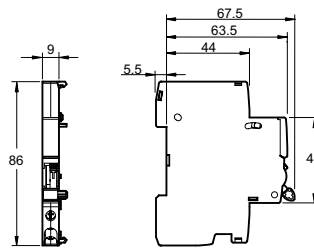

iOF, iSD

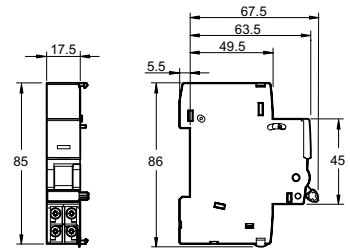

iMN, iMNs, iMNx, iMSU, iMX, iMX+OF

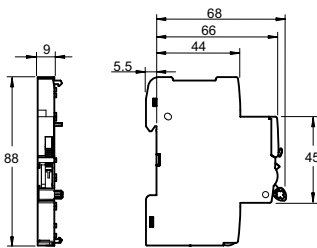

iOF+SD24 (A9A26897)

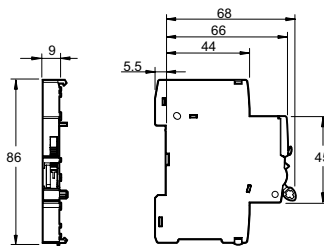

iOF+SD24 (A9A26898)

iMDU electrical auxiliary for Reflex iC60 or RCA iC60



A9C18195

The voltage matching module allows safety voltages of 24 and 48 V AC/DC to be used on the control inputs.

- Only connects to the Reflex iC60 circuit breakers remote controlled by a 220-240 V control voltage
- Galvanic isolation 6000 V
- Maximum combined power between terminals P and Y1/Y2: 100 mA at 230 V and 25°C.

Catalogue numbers

Auxiliary iMDU		
Type		Width in 9 mm modules
iMDU	A9C18195	1

Diagram

An iMDU electrical auxiliary allows up to a maximum of five Reflex iC60 to be controlled simultaneously at the same input Y1 or Y2.

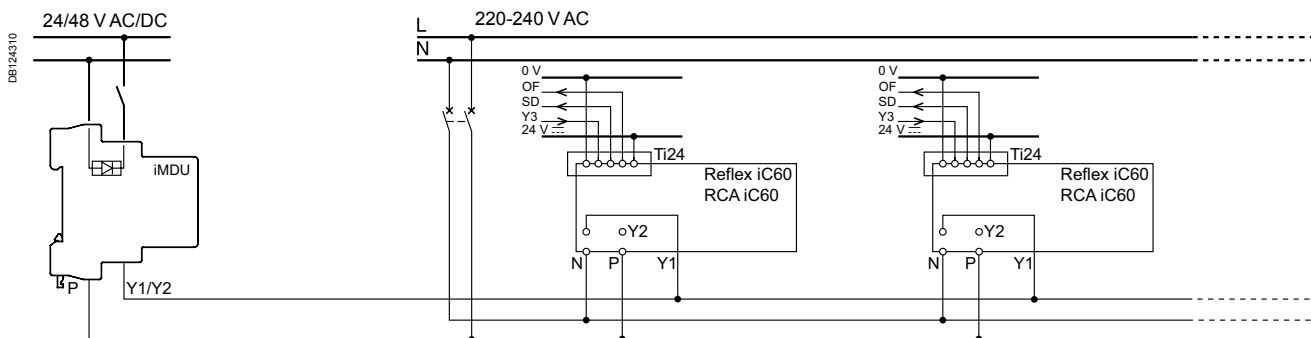

Dimensions (mm)

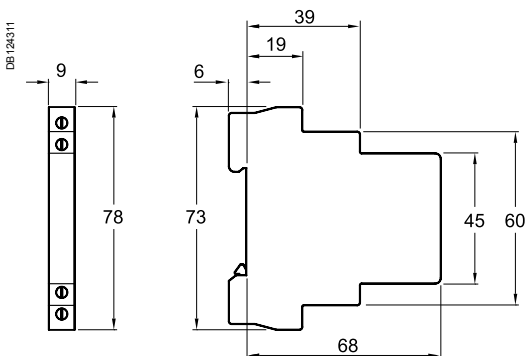

Connection

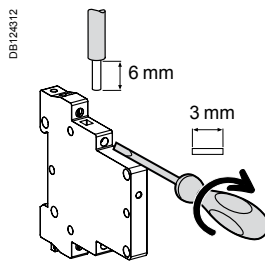

Type	Tightening torque	Copper cables	
		Rigid	Flexible or with ferrule
iMDU	1 N.m	1.5 mm ²	1.5 mm ²

Technical data

Main characteristics		
Control circuit voltage		24...48 V AC/DC
Insulation voltage (Ui)		500 V
Additional characteristics		
Degree of protection (IEC 60529)	Device only	IP20
	Device in modular enclosure	IP40
Operating temperature		-20°C to +60°C
Storage temperature		-40°C to +80°C
Tropicalization		Treatment 2 (relative humidity 95 % at 55°C)
Weight		53 g

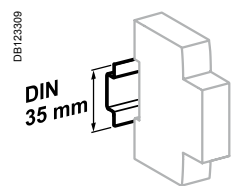

Clip on DIN rail 35 mm.

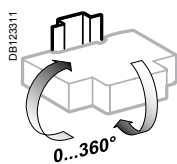

Indifferent position of installation.

Protection

Circuit protection / Earth leakage protection

Electrical auxiliaries for C60, C120, ID, C60H-DC, SW60-DC, C60PV-DC, C60NA-DC, C120NA-DC

- The electrical auxiliaries provide the remote tripping or position (open/closed/tripped) indication functions of these devices in the event of a fault.
- They clip on (no tool required) to the left-hand side of the associated device.
- The OF+SD/OF auxiliary is a two-in-one product: a mechanical selector switch is used to select one of two contacts: OF+SD or OF+OF.
- The OF+SD24 auxiliary can report open/closed (OF) status information and intentional or fault tripping of the associated device (SD) to the Acti 9 Smartlink or a programmable logic controller via the Ti24 interface (24 V DC).



- The electrical auxiliaries are not compatible with ID residual current circuit breakers of type B.

Tripping auxiliaries:

IEC/EN 60947-1

- MN: undervoltage release
- MN $\overline{}$: delayed undervoltage release
- MNx: undervoltage release, independent of the supply voltage
- MX: shunt release
- MX+OF: shunt release with open/closed contact.

EN 50550

- MSU: overvoltage release.

Indication auxiliaries:

IEC/EN 60947-5-1

- OF.S: open/closed contact for ID
- OF: open/closed contact
- SD: fault indicating contact
- OF+SD/OF: choice of open/closed contact and OF or SD contact via the selector switch
- OF+SD24: open/close contact OF and cfault indicating contact SD with Ti24 interface.

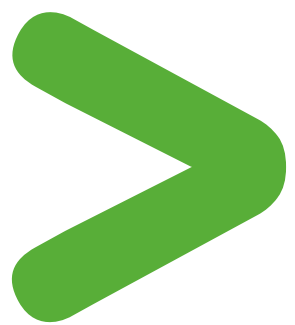

IEC/EN 60947-5-4

- OF+SD24: open/close contact OF and cfault indicating contact SD with Ti24 interface.



Circuit protection / Earth leakage protection

Electrical auxiliaries for C60, C120, ID, C60H-DC, SW60-DC, C60PV-DC, C60NA-DC, C120NA-DC (cont.)

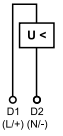
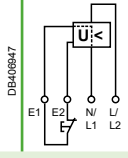

		Tripping					
Auxiliaries		MN		MN [□]		MNx	
Type		Undervoltage release					
		Instantaneous		Delayed		Independent of the supply voltage	
PE107151-30				PE107152-30			
PE107149-30							
Function		<ul style="list-style-type: none"> Causes the device with which it is associated to trip when its input voltage decreases (between 70 % and 35 % of U_n). Prevents the device from closing until its input voltage has been restored 				<ul style="list-style-type: none"> Tripping of the associated device by opening of the control circuit (e.g. push-button, dry contact) 	
		<ul style="list-style-type: none"> No tripping in the event of transient voltage dips (up to 0.2 s) 				<ul style="list-style-type: none"> A drop in the supply voltage does not trip the associated device A locking push-button control allows the circuit protected (e.g. machine control) to be placed in safety configuration 	
Wiring diagrams							
Utilization		<ul style="list-style-type: none"> Emergency stop via a normally-closed pushbutton Ensures the safety of the power supply circuits of several machines by preventing accidental startups 				<ul style="list-style-type: none"> Fail-safe emergency stop Insensitive to the variation in the control circuit voltage to improve continuity of service <p>Important: Before any servicing operation switch off the mains power supply (voltage presence at terminals E1/E2)</p>	
Catalogue numbers		A9N26960	A9N26961	A9N26959	A9N26963	A9N26969	A9N26971
C60, C120, DPN, DPN Vigi, ID		■	■	■	■	■	■
C60H-DC, SW60-DC, C60PV-DC, C60NA-DC, C120NA-DC		■	■	■	■	■	■
Technical specification							
Rated voltage (U _e)	V AC	220...240	48	115	220...240	230	400
	V DC	–	48	–	–	–	–
Standardised operating and non-response to voltage times (U _a)*		–	–	–	–	–	–
Maximum operating time		–	–	–	–	–	–
Minimum non-response time		–	–	–	–	–	–
Operating frequency	Hz	50/60		400	50/60	50/60	
		On front face			On front face	On front face	
Mechanical state indicator light, red		On front face			On front face	On front face	
Test function		–			–	–	
Width in 9 mm modules		2			2	2	
Operating current		–			–	–	
Number of contacts		–			–	–	
Operating temperature	°C	-25...+50			-25...+50	-25...+50	
	°C	-40...+85			-40...+85	-40...+85	
Storage temperature		-40...+85			-40...+85	-40...+85	
Standards							
IEC/EN 60947-1		■			■	■	
IEC/EN 60947-5-1		–			–	–	
EN 60947-2		■			■	–	
EN 62019-2 ⁽¹⁾		–			–	–	

(1) For C120, DPN.

*(U_a): Voltages measured between the phase and the neutral conductor, at which the MSU device must control the associated protective device.

Circuit protection / Earth leakage protection

Electrical auxiliaries for C60, C120, ID, C60H-DC, SW60-DC, C60PV-DC, C60NA-DC, C120NA-DC (cont.)

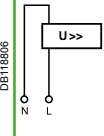
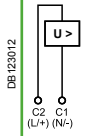
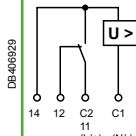
MSU						MX			MX+OF		
Voltage threshold release						Shunt release			With Open/Close auxiliary contact		
											
<ul style="list-style-type: none"> Cuts off the power supply by opening the device with which it is associated when the phase/neutral voltage is exceeded (loss of neutral). For a four-phase network, use three MSU tripping auxiliaries 						<ul style="list-style-type: none"> Trips the associated device when it is powered on 			<ul style="list-style-type: none"> Includes an open/close contact (OF) to indicate the "open" or "closed" position of the breaker 		
											
<ul style="list-style-type: none"> Protection of the devices against overvoltages on the electrical network (break in the neutral conductor) Monitoring the voltage between the phase conductor and the neutral conductor 						<ul style="list-style-type: none"> Emergency stop via a normally-open pushbutton. 			<ul style="list-style-type: none"> Emergency stop via a normally-open pushbutton Remote indication of the position of the associated device 		
A9N26500						A9N26476	A9N26477	A9N26478	A9N26946	A9N26947	A9N26948
■						■	■	■	■	■	■
-						■	■	■	■	■	■
230						100...415	48	12...24	100...415	48	12...24
-						110...130	48	12...24	110...130	48	12...24
255 V AC						275 V AC	300 V AC	350 V AC	400 V AC	-	-
No tripping						15 s	5 s	0.75 s	0.20 s	-	-
-						3 s	1 s	0.25 s	0.07 s	-	-
50/60						50/60			50/60		
On front face						On front face			On front face		
-						-			-		
2						2			2		
-						-			10 mA mini, 6 A maxi		
-						-			≤ 24 V DC	6 A	
-						-			48 V DC	2 A	
-						-			≤ 130 V DC	1 A	
-						-			≤ 240 V AC	6 A	
-						-			415 V AC	3 A	
-						-			1 NO/NC		
-25...+50						-25...+50			-25...+50		
-40...+85						-40...+85			-40...+85		
■						■			■		
-						-			-		
-						-			-		
-						-			-		

Circuit protection / Earth leakage protection

Electrical auxiliaries for C60, C120, ID, C60H-DC, SW60-DC, C60PV-DC, C60NA-DC, C120NA-DC (cont.)

		Indication				
Auxiliaries		OF.S	OF	SD	OF+SD/OF	OF+SD24
Type		Open/closed auxiliary contact	Open/closed auxiliary contact	Fault indicating contact	Double open/closed or fault indicating contact	Double open/close and fault indicating contact
Function		<ul style="list-style-type: none"> Changeover contact indicating the "open" or "closed" position of the associated device <p>⚠ Compulsory for the addition of tripping or indication auxiliaries on a residual current circuit breaker ID</p>	<ul style="list-style-type: none"> Changeover contact indicating the "open" or "closed" position of the associated device 	<ul style="list-style-type: none"> Changeover contact indicating the position of the associated device in the event of: <ul style="list-style-type: none"> □ electrical fault □ action on the tripping auxiliary <p>⚠ Not compatible with a ID residual current circuit breaker, use an OF+SD/OF in the SD position</p>	<ul style="list-style-type: none"> The OF+SD/OF auxiliary is a two-in-one product: choice of OF + SD or OF + OF contact via the selector switch 	<ul style="list-style-type: none"> 2 contacts (1 NO + 1 NC) can report the signalling information of the associated device to the Acti 9 Smartlink or a programmable logic controller: <ul style="list-style-type: none"> □ electrical fault □ actuation of the tripping auxiliary □ "Open" or "Closed" position of the associated device
Wiring diagrams						
Utilization		<ul style="list-style-type: none"> Remote indication of the position of the associated device 	<ul style="list-style-type: none"> Remote indication of the position of the associated device 	<ul style="list-style-type: none"> Remote fault tripping indication of the associated device 	<ul style="list-style-type: none"> Remote position and/or fault tripping indication of the associated device 	<ul style="list-style-type: none"> Remote indication of position and tripping upon a fault of the associated breaker
Catalogue numbers		A9N26923	A9N26924	A9N26927	A9N26929	A9N26899
ID		■	■	■	■	■
C60, C120, DPN, DPN Vigi, C60H-DC, C60H-DC, SW60-DC, C60PV-DC, C60NA-DC, C120NA-DC		—	■	■	■	■
Technical specification						
Rated voltage (Ue)	V AC	24...415	24...415	24...415	24...415	—
	V DC	24...130	24...130	24...130	24...130	24
Operating frequency	Hz	50/60	50/60	50/60	50/60	—
Mechanical state indicator		—	—	On front face	On front face	On front face
Test function		—	On front face	On front face	On front face	On toggle
Width in 9 mm modules		1	1	1	1	1
Operating current	10 mA mini, 6 A maxi					
	24 V DC	6 A				2 mA mini, 100 mA maxi
	48 V DC	2 A				—
	60 V DC	1.5 A				—
	130 V DC	1 A				—
	24...240 V AC	6 A				—
415 V AC	3 A				—	
Number of contacts		1 NO/NC	1 NO/NC	1 NO/NC	1 NO/NC + 1 NO/NC	1 NO + 1 NC
Operating temperature	°C	-25...+50	-25...+50	-25...+50	-25...+50	-25...+70
	°C	-40...+85	-40...+85	-40...+85	-40...+85	-40...+85
Standards						
IEC/EN 60947-1		—	—	—	—	—
IEC/EN 60947-5-1		■	■	■	■	■ IEC 60947-5-4
EN 60947-2		—	—	—	—	—
EN 62019-2 ⁽¹⁾		■	■	■	■	—

(1) For C120, DPN.

Protection

Circuit protection / Earth leakage protection

Electrical auxiliaries for C60, C120, ID, C60H-DC, SW60-DC, C60PV-DC, C60NA-DC, C120NA-DC (cont.)

Connection

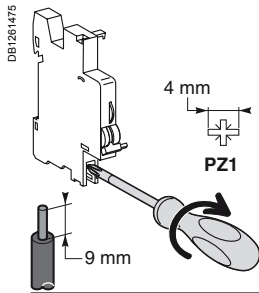

Type	Tightening torque	Copper cables	
		Rigid	Flexible or with ferrule
Indication and tripping auxiliaries	1 N.m	0.5 to 2.5 mm ²	2 x 1.5 mm ²

Ti24 connector connection

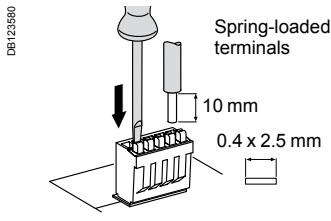

Type	Catalogue numbers	Copper cables	
		Rigid	Flexible
Ti24 interface	A9XC2412	1 x 0.5 to 1.5 mm ²	1 x 0.5 to 1.5 mm ²

Ti24 prefabricated cables connection

Type	Catalogue numbers	Length
Connection for Acti 9 Smartlink		
PB 107754-10 	A9XCAS06	100 mm
	A9XCAM06	160 mm
	A9XCAH06	450 mm
	A9XCAL06	870 mm
Connection for PLC type terminals		
PB 107755-14 	A9XCAU06	870 mm
	A9XCAC01	4000 mm
DB404941 		
PB 107756-7 	A9XC2412	-

Protection

Circuit protection / Earth leakage protection

Electrical auxiliaries for C60, C120, ID, C60H-DC, SW60-DC, C60PV-DC, C60NA-DC, C120NA-DC (cont.)

Dimensions

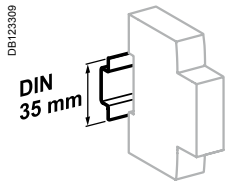
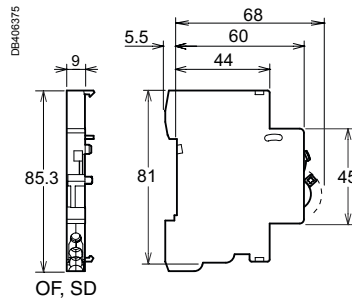
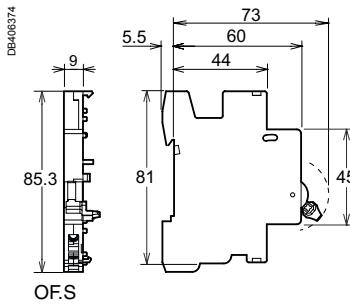
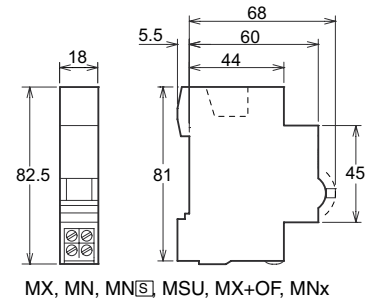
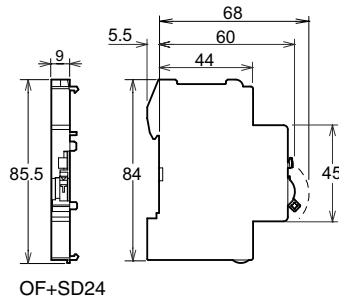
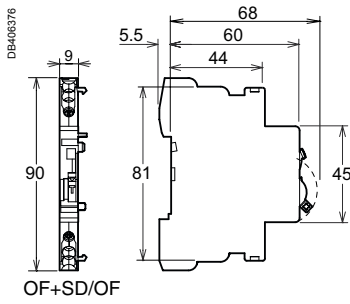

Clip on DIN rail 35 mm.

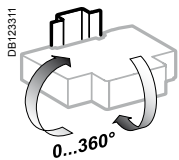

Indifferent position of installation.

Weight (g)

Electrical auxiliaries	
Type	Weight (g)
MN	66
MN⊠	66
MNx	73
MSU	66
MX	60
MX+OF	65
OF.S	33
OF	30
SD	30
OF+SD/OF	38
OF+SD24	28

Electrical auxiliaries for NG125 devices

- The electrical auxiliaries are combined with NG125 circuit breakers and NG125 switch-disconnectors; they provide the remote tripping or position (open/closed/tripped) indication functions of these devices in the event of a fault.
- They clip on (no tool required) to the left-hand side of the associated device.

IEC/EN 60947-2

- Tripping auxiliaries:
 - MN: undervoltage release
 - MNx: undervoltage release, independent of the supply voltage
 - MX+OF: shunt release with open/closed contact
 - MXV: shunt release for Vigi add-on residual current device.

IEC/EN 60947-5-1

- Indication contacts:
 - OF+OF: open/closed contact
 - OF+SD: fault indicating contact
 - MX+OF: shunt release with open/closed contact.





Combination table

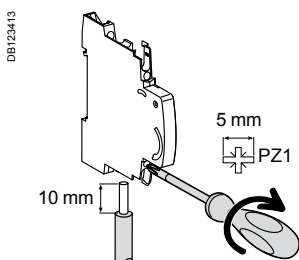

Electrical auxiliaries		Device
Indication auxiliaries	Tripping auxiliaries	 05862N_SE-30 NG125
2 (OF+OF or OF+SD)	Max. quantity + 1 (MX+OF or MN or MNx)	

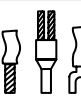
Connection



Type	Tightening torque	Copper cables		Multi-cable terminal	
		Rigid	Flexible or with ferrule	Flexible or rigid cables	Cables with ferrule
Indication contacts	1 N.m	 DB122845 0.5 to 2.5 mm ²	 DB123411 0.5 to 1.5 mm ²	 DB123011 2 x 2.5 mm ²	 DB123412 2 x 1.5 mm ²
Tripping auxiliaries	1 N.m	0.5 to 2.5 mm ²	0.5 to 1.5 mm ²	2 x 2.5 mm ²	2 x 1.5 mm ²

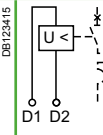
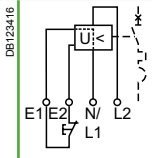
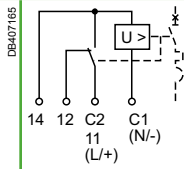

Electrical auxiliaries for NG125 devices and for Vigi NG125 add-on residual current devices (cont.)

		Tripping							
Auxiliaries		MN			MNx		MX+OF		
Type		Undervoltage release						Shunt release	
		Instantaneous			Independent of the supply voltage			With open/closed auxiliary contact	
									
Function		<ul style="list-style-type: none"> Causes tripping of the device with which it is combined when its input voltage decreases (between 70% and 35% of U_n). Prevents closing of the device until its input voltage has been restored 			<ul style="list-style-type: none"> Tripping of the associated device by opening of the control circuit (e.g. push-button, dry contact) A drop in the supply voltage does not trip the associated device A locking push-button control allows the circuit protected (e.g. machine control) to be placed in safety configuration 			<ul style="list-style-type: none"> Causes tripping of the associated device when powered Includes an open/closed contact (OF) to indicate the "open" or "closed" position of the associated device 	
Wiring diagrams									
Utilization		<ul style="list-style-type: none"> Emergency stop by normally-closed pushbutton Ensures safety of the power supply circuits for several machines by preventing untimely restarting 			<ul style="list-style-type: none"> Fail-safe emergency stop Insensitive to variations in the control circuit voltage for improved continuity of service Important: Before any servicing operation switch off the mains power supply (voltage presence at terminals E1/E2) 			<ul style="list-style-type: none"> Provided with a self-interrupting contact 	
Catalogue numbers		19067	19069	19070	19061	19064	19065	19066	19063
Technical specification									
Rated voltage (U_e)	V AC	230...240	48	—	220...240	230...415	48...130	24	12
	V DC	—	—	48	—	110...130	48	24	12
Operating frequency	Hz	50/60			50/60	50/60			
Mechanical state indicator light, red		On front face			On front face	On front face			
Width in 9 mm modules		2			4	2			
Current rating		—			—	415 V AC		3 A	
		—			—	≤ 240 V AC		6 A	
		—			—	130 V DC		1 A	
		—			—	≤ 48 V DC		3 A	
Number of contacts		—			—	—			
Operating temperature	°C	-25...+60			-25...+60	-25...+60			
Storage temperature	°C	-40...+85			-40...+85	-40...+85			



Protection Circuit protection

Electrical auxiliaries for NG125 devices and for Vigi NG125 add-on residual current devices (cont.)

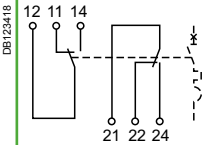
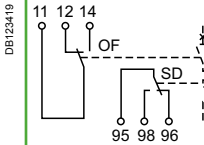
Indication

OF+OF		OF+SD	
Auxiliary contact		Fault indicating contact	
			
<ul style="list-style-type: none"> ■ Double changeover contact indicating "open" or "closed" position of the associated device 		<ul style="list-style-type: none"> ■ Double changeover contact indicating: <ul style="list-style-type: none"> □ the position of the associated device in the event of: <ul style="list-style-type: none"> - electrical fault - actuation of the tripping auxiliary □ the "open" or "closed" position of the associated device 	
			
<ul style="list-style-type: none"> ■ Remote indication of the position of the associated device 		<ul style="list-style-type: none"> ■ Remote indication of tripping upon a fault of the associated device 	
19071		19072	
-		-	
-		-	
50/60		50/60	
-		-	
1		1	
415 V AC 3 A		415 V AC 3 A	
≤ 240 V AC 6 A		≤ 240 V AC 6 A	
130 V DC 1 A		130 V DC 1 A	
≤ 48 V DC 3 A		≤ 48 V DC 3 A	
2 NO/NC		2 NO/NC	
-25...+60		-25...+60	
-40...+85		-40...+85	

Electrical auxiliaries for NG125 devices and for Vigi NG125 add-on residual current devices (cont.)

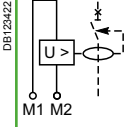
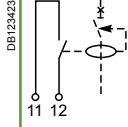
		Indication	
Auxiliaries		MXV	SDV
Type		Shunt release	Vigi fault indicating contact
			
Function		<ul style="list-style-type: none"> At power up, actuates tripping of a circuit breaker or residual current circuit breaker It is provided with a self-interrupting contact 	<ul style="list-style-type: none"> Normally-closed or normally-open contact indicating tripping upon an earth fault (including tripped by MXV)
Wiring diagrams			
Utilization		<ul style="list-style-type: none"> Adaptable to 125 A Vigi add-on residual current device, all types, and to 63 A Vigi add-on residual current device, adjustable Impulse withstand voltage: 6 kV High-impedance input: use an iACTp if the leakage current in the control unit exceeds 1 mA (e.g. illuminated pushbutton) 	
Catalogue numbers		19060	19058 19059
Suitable for the following devices:			
NG125	-		-
Vigi NG125	■		■
Technical specification			
Rated voltage (Ue)	V AC	110...240	250
	V DC	110	-
Operating frequency	Hz	50/60	50/60
Number of contacts		-	1 NO 1 NC
Current rating		-	0.1 to 1 A (AC14)
Operating temperature	°C	-25...+60	-25...+60
Storage temperature	°C	-40...+85	-40...+85

Control

Remote control

RCA remote controls

For iC60 circuit breakers



The RCA remote control system allows:

- Remote electrical control (opening and closing) of circuit breakers with or without Vigi add-on RCD, with or without auxiliary.
- Circuit-breaker resetting after tripping, in accordance with safety principles and the regulations in force.
- Local control by operating handle.
- Circuit placing in safety configuration by padlocking.

2 choices of operation after tripping:

- A: Enabling of remote circuit-breaker resetting;
- B: Inhibition of remote resetting.

The version with Ti24 interface allows:

- Direct interfacing of remote control with a programmable logic controller (PLC), a supervision system and any other communication device, having inputs/outputs in 24 V DC (control, OF and SD indications).
- Fast, reliable connection of the remote control to the Acti 9 Smartlink thanks to the prefabricated cables.
- Remote indication by "OF" potential-free contact.
- Provision of 2 operating modes, "1 and 3".

The iMDU auxiliary allows RCA control in 24/48 V AC/DC.

Catalogue numbers

RCA remote control			
Type			Width in 9 mm modules
For circuit breakers 1P, 1P+N, 2P	Voltage		
Without Ti24 interface	230 V AC, 50/60 Hz	A9C70112	7
With Ti24 interface	230 V AC, 50/60 Hz	A9C70122	7
For 3P, 4P circuit breakers			
Without Ti24 interface	230 V AC, 50/60 Hz	A9C70114	7
With Ti24 interface	230 V AC, 50/60 Hz	A9C70124	7
Auxiliaries		See module CA907000 and CA907002	



Without Ti24 interface

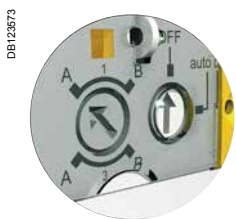

With Ti24 interface

Type		Application
OFF		All remote control inhibited
auto	A	Circuit breaker remote reclosing after tripping allowed
	B	Circuit breaker remote reclosing after tripping inhibited
Green indicator lamp		Remote control possible
Orange indicator lamp		Remote control impossible
1 (Ti24)		Mode 1
3 (Ti24)		Mode 3
Y1		Latched order local control
Y2		Impulse-type or latched order local control (depending on mode)
Y3		Latched order centralized control

Control

Remote control

RCA remote controls (cont.)

For iC60 circuit breakers

Standard RCA

The orders received on terminals Y1 and Y2 are taken into account progressively in their order of arrival.

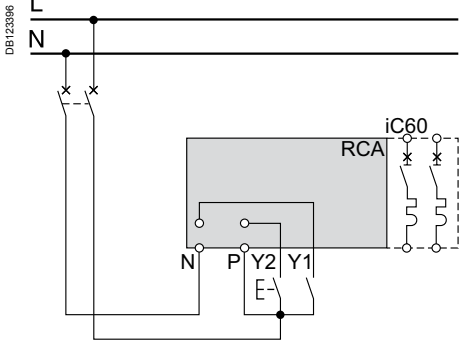

RCA Ti24

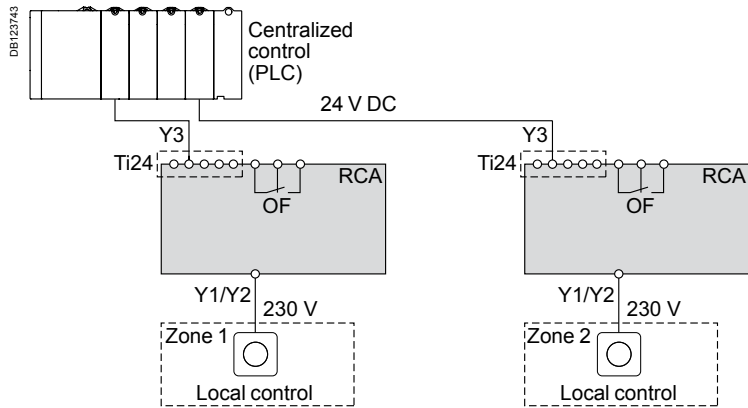

Mode 1: Locally or centrally controlled circuit-breaker opening/closing

- The orders come from various control points, and they are taken into account in their order of arrival
- Y1: Latched order local control
- Y2: Impulse-type local control
- Y3: Latched order centralized control

RCA Ti24 mode 1

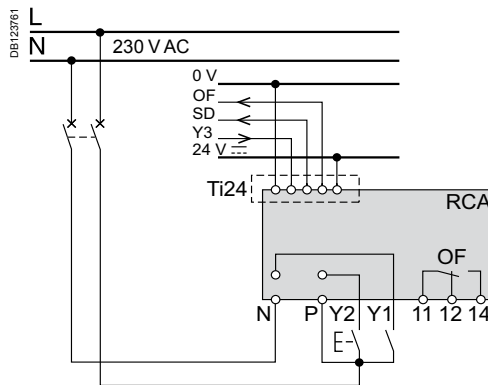

Mode 3: Centrally controlled opening/closing + local override

- 3 positions allowing a choice between override and centralized control:
- Y1: Latched order local control
- Y2: Latched order local control
- Y3: Latched order centralized control

RCA Ti24 mode 3

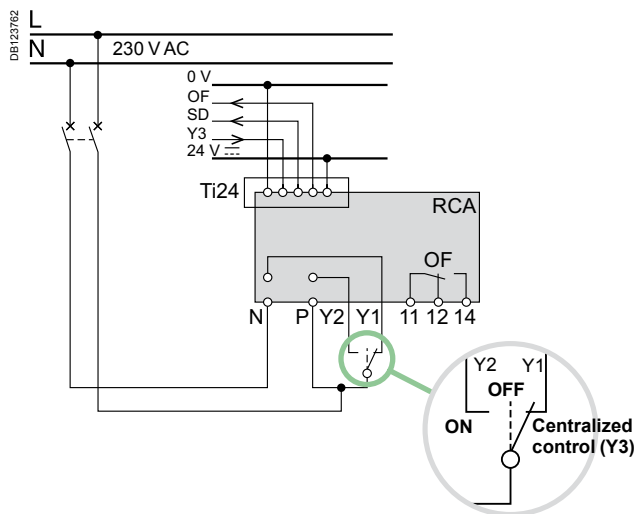

Control

Remote control

RCA remote controls (cont.)

For iC60 circuit breakers

DB123576

- Ti24 interface for link to PLC and Acti 9 Smartlink
- Operating state indicator lamp
- Compatible with the circuit breaker's electrical auxiliaries
- Lead sealing of operating modes
- ComReady
- Locking device capable of neutralizing remote control and padlocking (Ø 3 to 6 mm) in open position
- Selector switch for inhibition of all electrical controls
- Operating state indicator lamp
- Latched order or impulse-type control
- Bistable operation: does not change state in the event of electrical power outage

DB123763

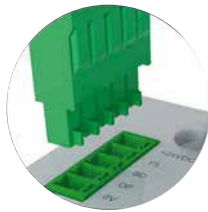

Legend	
Type	Application
+24VDC	V DC power supply
Y3	Latched order centralized control
SD	Circuit-breaker tripping information
OF	Control circuit state information (open/closed)
0 V	V DC power supply

DB123578



DB123579

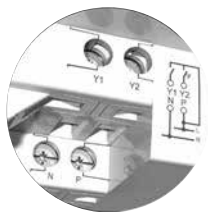

Y1	Latched order local control
Y2	Impulse-type or latched order local control (depending on mode)
N	230 V AC power supply
P	
OF	Circuit-breaker state indication contact (open/closed)



Control Remote control

RCA remote controls (cont.)

For iC60 circuit breakers

Connection

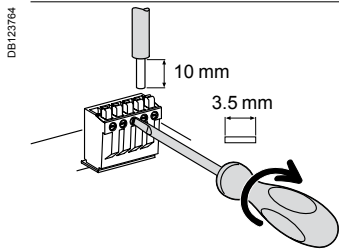
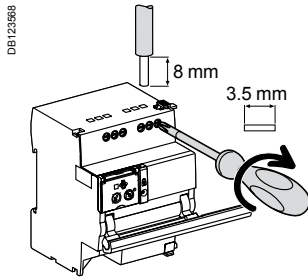
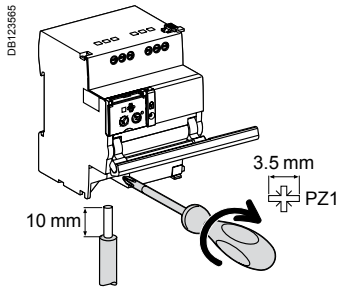

Terminal	Tightening torque	Without accessories		
		Copper cables		
		Rigid	Flexible	Flexible with ferrule
Power supply (N/P) Inputs (Y1/Y2)	1 N.m	0.5 to 10 mm ² 2 x 0.5 to 2 x 2.5 mm ²	0.5 to 6 mm ² 2 x 0.5 to 2 x 2.5 mm ²	0.5 to 4 mm ² 2 x 0.5 to 2 x 2.5 mm ²
Outputs (OF)	0.7 N.m	0.5 to 2.5 mm ² 2 x 0.5 to 2 x 1.5 mm ²	0.5 to 2.5 mm ² 2 x 0.5 to 2 x 1.5 mm ²	0.5 to 1.5 mm ² 2 x 0.5 to 2 x 1.5 mm ²
Ti24 interface	Spring-loaded terminals	0.5 to 1.5 mm ²	0.5 to 1.5 mm ²	-

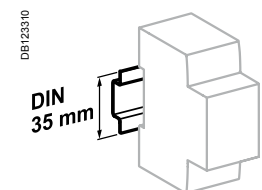

Clip on DIN rail 35 mm.

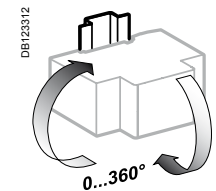

Indifferent position of installation.

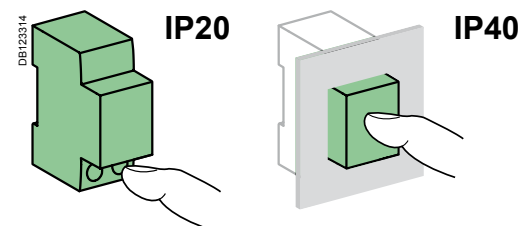

Technical data

Control circuit		
Supply voltage (Ue) (N/P)		230 V AC, 50/60 Hz
Control voltage (Uc)	Type 1 inputs (Y1/Y2)	230 V AC (as per IEC 61131-2)
Min. duration of control order (Y2)		≥ 200 ms
Response time (Y2)		< 500 ms
Consumption		≤ 1 W
Thermal self-protection with automatic Reset against overheating of the control circuit due to an abnormal number of operations		
Endurance (O-C) (RCA combined with a circuit breaker)		
Electrical/Mechanical		10,000 cycles
Indication / Remote control		
Potential free changeover contact output (OF)	Min.	24 V AC/DC, 10 mA
	Max.	230 V AC, 1 A
Input (Y1/Y2)	230 V AC	5 mA
Ti24 interface (as per IEC 61131)		
Type 1 input (Y3)	24 V DC	5.5 mA
Output (OF and SD)	24 V DC	In max.: 100 mA
Additional characteristics		
Degree of protection (IEC 60529)	Device only	IP20
	Device in a modular enclosure	IP40
		Insulation class II
Insulation voltage (Ui)		400 V
Degree of pollution (IEC 60947)		3
Rated impulse withstand voltage (Uimp)		6 kV
Operating temperature		-25°C to +60°C
Storage temperature		-40°C to +70°C
Tropicalization		Treatment 2 (relative humidity of 93 % at +40°C)

RCA remote controls (cont.)

For iC60 circuit breakers

Weight (g)

Remote controls	
Type	RCA
For 1P, 1P+N, 2P circuit breakers	400
For 3P, 3P+N, 4P circuit breakers	430

Dimensions (mm)

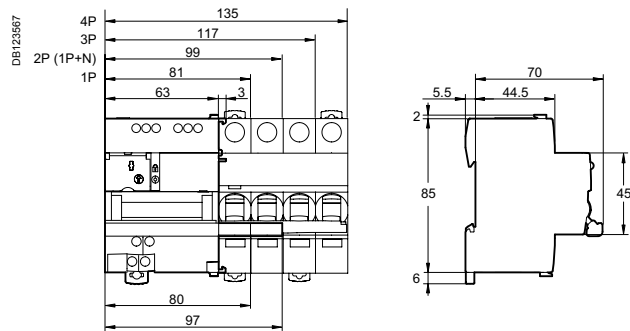

Control

Local control

iPB pushbuttons

IEC 60669-1 and IEC 60947-5-1

■ iPB pushbuttons are used to control electric circuits by means of pulses.

Catalogue numbers

iPB pushbuttons														
Type	Single				Double		Single + indicator light							
Diagram	1 NC 3 E-7 4		1 NO 1 E-7 2		1 NO + 1 NC 1 3 E-7 2 4		1 NO / 1 NC 1 3 E-7 E-7 2 4		1 NO / 1 NO 1 3 E-7 E-7 2 4		1 NO 1 NC 1 X1 3 X1 E-7 X 2 X2 4 X2		1 NO 1 NC 1 X1- 3 X1- E-7 X 2 X2+ 4 X2+	
Pushbutton Colour	Grey	Red	Grey	Grey	Green/red	Grey/grey	Grey	Grey	Grey	Grey	Grey	Grey		
Indicator light Power supply	-	-	-	-	-	-	110...230 V AC		12...48 V AC/DC					
Indicator light Colour	-	-	-	-	-	-	Green	Red	Green	Red	Green	Red		
Cat. no.	A9E18030	A9E18031	A9E18032	A9E18033	A9E18034	A9E18035	A9E18036	A9E18037	A9E18038	A9E18039				
Width in 9 mm modules	2				2		2							

Connection

Tightening torque	Copper cables	
	Rigid	Flexible or with ferrule
1 N.m	DB122345	DB122346
	0.5 mm ² min. 2 x 2.5 mm ² max.	0.5 mm ² min. 2 x 2.5 mm ² max.

- Phase-separated wall that can be divided to allow the teeth of all types of comb busbar to pass through.
- Staggered terminals to simplify connection.

Dimensions (mm)

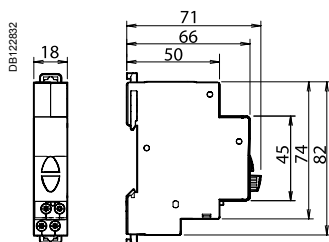

Technical data

Main characteristics	
Pollution degree	3
Power circuit	
Voltage rating (Ue)	250 V AC
Current rating (Ie)	20 A
Additional characteristics	
Endurance (O-C)	30,000 operations AC22 (cos φ = 0.8)
Operating temperature	-35°C... +70°C
Storage temperature	-40°C... +80°C
Tropicalization	Treatment 2 (relative humidity 95 % at 55°C)
LED indicator light	Consumption: 0.3 W Service life: 100,000 hours of constant lighting efficiency Maintenance-free indicator light (non-interchangeable LEDs)

Control



Local control

iSSW linear switches

IEC 60669-1 and IEC 60947-5-1

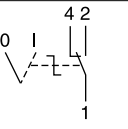
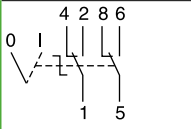
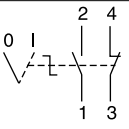
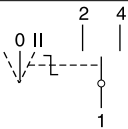
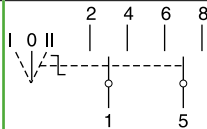

■ iSSW linear switches are used for the manual control of electric circuits.

Catalogue numbers

iSSW linear switches					
Type	2 positions			3 positions	
					
Contact	1 changeover switch	2 changeover switches	1 NO + 1NC	1 changeover switch	2 changeover switches
Diagram					
Cat. no.	A9E18070	A9E18071	A9E18072	A9E18073	A9E18074
Width in 9 mm modules	2	4	2	2	4

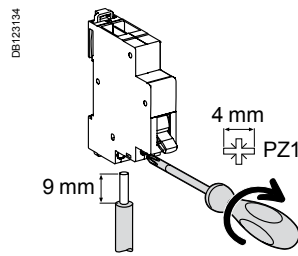
Connection



Tightening torque	Copper cables	
	Rigid	Flexible or with ferrule
1 N.m	 DB122945	 DB122946
	0.5 mm ² min. 2 x 2.5 mm ² max.	0.5 mm ² min. 2 x 2.5 mm ² max.

- Phase-separated wall that can be divided to allow the teeth of all types of comb busbar to pass through.
- Staggered terminals to simplify connection.

Dimensions (mm)

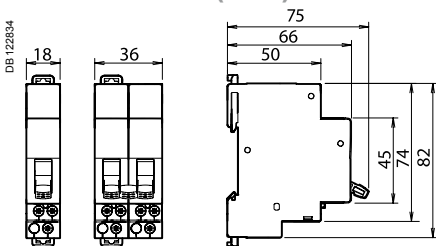



Technical data

Main characteristics	
Pollution degree	3
Power circuit	
Voltage rating (Ue)	250 V AC
Current rating (Ie)	20 A
Additional characteristics	
Endurance (O-C)	30,000 cycles AC22 (cos φ = 0.8)
Operating temperature	-20°C... +50°C
Storage temperature	-40°C... +70°C
Tropicalization	Treatment 2 (relative humidity 95 % at 55°C)

DIN rail selector switches

iCMB, iCMD, iCME, iCMC, iCMV and iCMA

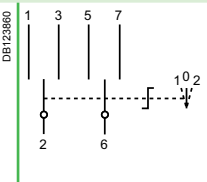
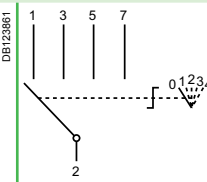
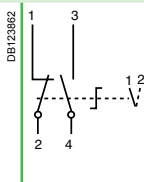
		Control																													
Selector switches		iCMB	iCMD	iCME																											
Type		Two-pole with zero setting	4-way	2-way for electronic circuits																											
In compliance with standards		IEC 60947-3 (EN 60947-3) VDE 0660 part. 107 UL	IEC 60947-3 (EN 60947-3) VDE 0660 part. 107 UL	IEC 60947-3 (EN 60947-3) VDE 0660 part. 107 UL																											
																															
Function		<ul style="list-style-type: none"> This two-pole selector switch with zero setting allows manual control of a circuit with 2-way operation (non-locking) with a stop position 	<ul style="list-style-type: none"> This 4-way selector switch allows control of a circuit with operating priorities 	<ul style="list-style-type: none"> This 2-way selector switch is used specially for the control of electronic circuits of low voltage and current level 																											
Wiring diagrams																															
Use		<p>Example: electrically controlled metal screen:</p> <ul style="list-style-type: none"> position 1 = raising position 0 = stop position 2 = lowering <p>Zero setting product, positions 1 and 2 must be maintained on the rotative handle by the operator</p>	<p>Example: fan control:</p> <ul style="list-style-type: none"> position 0 = stop position 1 = override operation, slow speed position 2 = override operation, high speed position 3 = remote control position 4 = automatic operation 	<ul style="list-style-type: none"> Voltage range from 30 mV to 600 V AC 																											
Catalogue numbers		A9E15120	A9E15121	A9E15122																											
Technical specification																															
Rated voltage (Ue)	V AC	415	415	See following table																											
Maximum operating voltage	V	440	440	440																											
Rating	A	10	10	See following table																											
Operating frequency	Hz	50/60	50/60	50/60																											
Width in 9-mm modules		4	4	4																											
Breaking capacity (resistive load)		–	–	<table border="1"> <thead> <tr> <th></th> <th>V AC</th> <th>V DC</th> </tr> </thead> <tbody> <tr> <td>1 V</td> <td>5 A</td> <td>3 A</td> </tr> <tr> <td>12 V</td> <td>1.2 A</td> <td>0.7 A</td> </tr> <tr> <td>24 V</td> <td>0.7 A</td> <td>0.4 A</td> </tr> <tr> <td>48 V</td> <td>0.45 A</td> <td>0.25 A</td> </tr> <tr> <td>110 V</td> <td>0.25 A</td> <td>0.13 A</td> </tr> <tr> <td>240 V</td> <td>0.15 A</td> <td>0.08 A</td> </tr> <tr> <td>300 V</td> <td>0.13 A</td> <td>0.07 A</td> </tr> <tr> <td>440 V</td> <td>0.1 A</td> <td>0.05 A</td> </tr> </tbody> </table>		V AC	V DC	1 V	5 A	3 A	12 V	1.2 A	0.7 A	24 V	0.7 A	0.4 A	48 V	0.45 A	0.25 A	110 V	0.25 A	0.13 A	240 V	0.15 A	0.08 A	300 V	0.13 A	0.07 A	440 V	0.1 A	0.05 A
	V AC	V DC																													
1 V	5 A	3 A																													
12 V	1.2 A	0.7 A																													
24 V	0.7 A	0.4 A																													
48 V	0.45 A	0.25 A																													
110 V	0.25 A	0.13 A																													
240 V	0.15 A	0.08 A																													
300 V	0.13 A	0.07 A																													
440 V	0.1 A	0.05 A																													
Operating temperature	°C	-20...+55	-20...+55	-20...+55																											
Storage temperature	°C	-25...+80	-25...+80	-25...+80																											

DDIN rail selector switches

iCMB, iCMD, iCME, iCMC, iCMV and iCMA (cont.)

	iCMC	iCMV	iCMA
	2-way key-actuated	7-position voltmeter	4-position ammeter
	IEC 60947-3 (EN 60947-3) VDE 0660 part. 107 UL	IEC 60947-3 (EN 60947-3) VDE 0660 part. 107 UL	IEC 60947-3 (EN 60947-3) VDE 0660 part. 107 UL
			
	<ul style="list-style-type: none"> 2-way key-actuated selector switch (key Ronis 601 type) with locking in one or the other position 	<ul style="list-style-type: none"> This 7-position voltmeter selector switch makes it possible, with a single voltmeter, to measure in succession the voltages (phase-to-phase and phase-to-neutral) of a three-phase circuit 	<ul style="list-style-type: none"> This 4-position ammeter selector switch makes it possible, with a single ammeter (using current transformers), to measure in succession the currents of a three-phase circuit
			
	-	-	-
	A9E15123	15125	15126
	415	415	415
	440	440	440
	10	10	10
	50/60	50/60	
	4	4	4
	-	-	-
	-	-	-
	-	-	-
	-	-	-
	-20...+55	-20...+55	-20...+55
	-25...+80	-25...+80	-25...+80

DIN rail selector switches

iCMB, iCMD, iCME, iCMC, iCMV and iCMA (cont.)

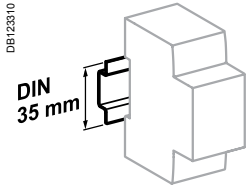

Clip on DIN rail 35 mm.

Connection

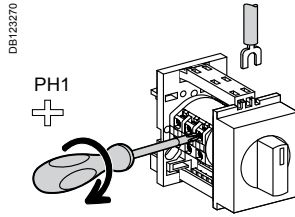

Tightening torque

0.35 N.m

Copper cables

Flexible or rigid with ferrule



< 1.5 mm²

- Connection by jumper terminals with captive screws.

Technical data

Additional characteristics

Degree of protection	Device only	IP20
Endurance (O-C)	Electrical	1,000,000 switching operations
	Mechanical	2,000,000 switching operations (AC21A-3 x 440 V)

Weight (g)

Selector switches

Type	Weight (g)
iCMA	58
iCMB	58
iCMC	70
iCMD	58
iCME	44
iCMV	58

Dimensions (mm)

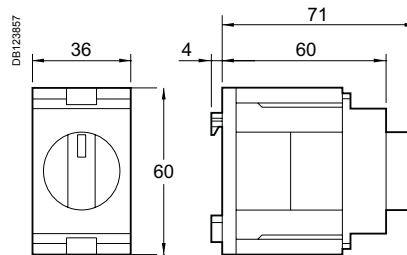

Local control Control Button holders

They can be attached to a symmetrical 35 mm rail, in modular cabinets or enclosures, for control and indications auxiliaries: push-buttons, emergency stops, switches, light indicators; for tertiary and industrial applications.



A9A1511

A9A1512

Catalogue numbers

Button holders		
Type		Width in 9 mm modules
Ø 22 mm button holder	A9A1511	6
Universal support	A9A1512	6

Technical data

Main characteristics	Button holder	Universal support
For buttons, switches and indicators with metal or plastic flange Ø 22 of the Schneider Electric XB4 / XB5 type	■	-
For buttons, indicators, light emitting diodes (LED), potentiometers	-	■
Drilling diameter	Ø 22.3 mm	Easy drilling, to be adapted depending on use
Colour	White RAL 9003	
Self-extinguishing insulating material		
Depth under rail 60 mm (same as products)		

Dimensions (mm)

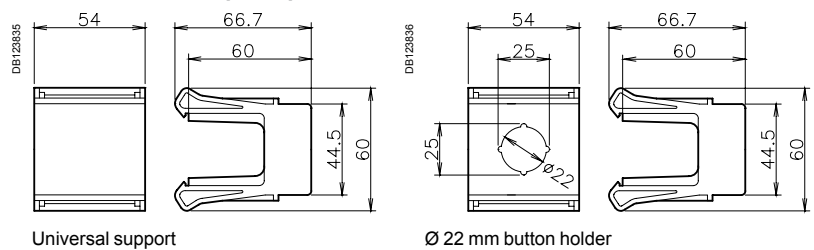

Universal support

Ø 22 mm button holder

Control

Remote control

Acti9 iCT contactors (cont.)

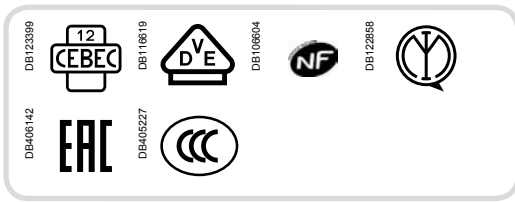

IEC/EN 61095

As per the above standards:
Acti9 iCT contactors are available in two versions:

- Contactors without manual operation
- Contactors with manual operation.

The breadth of the Acti9 iCT contactor range satisfies most application cases.
 Acti9 iCT contactors can be combined with auxiliary control, protection and indication functions.

- Acti9 iCT contactors can be used to remote control applications in alternating current:
 - lighting, heating, ventilation, roller blinds, sanitary hot water,
 - mechanical ventilation systems, etc,
 - load-shedding of non-priority circuits.

> Contactors

> Contactor auxiliaries

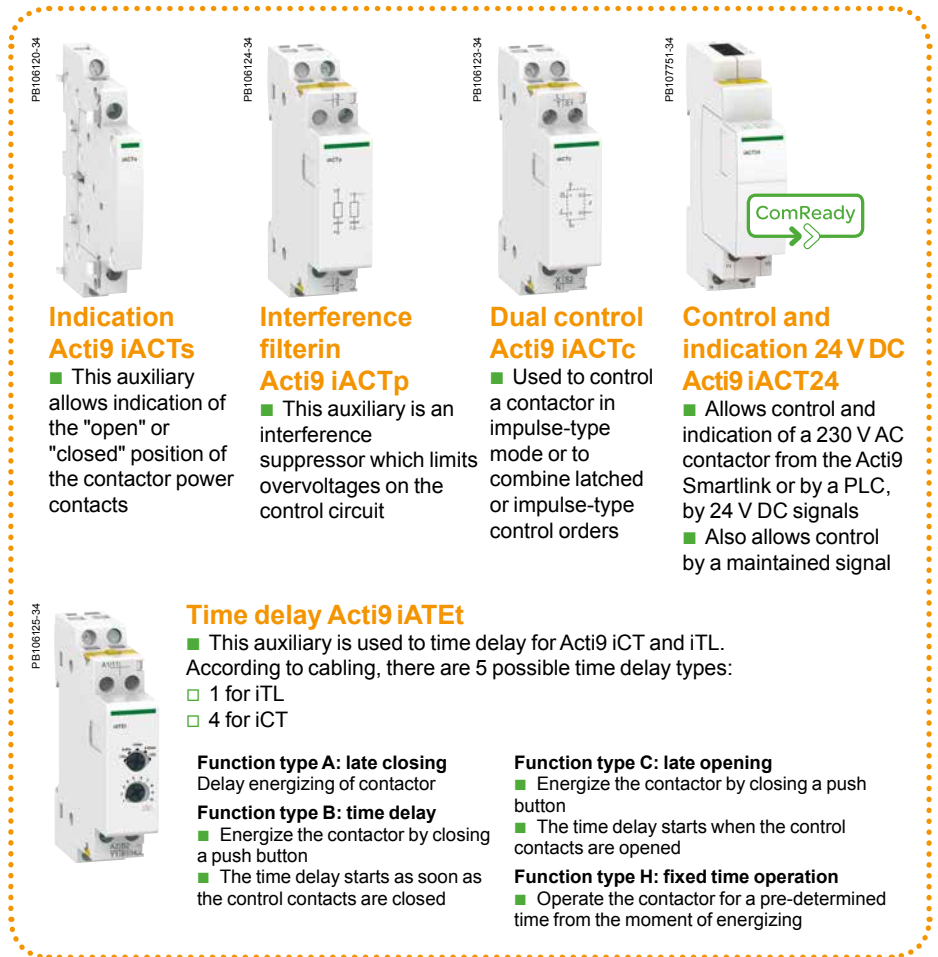

		Choice of 50 Hz contactors									
Type		Contactor					Manually-operated contactors				
Rating	A	16	20	25	40	63	100	16	25	40	63
Auxiliaries		Contactors that can be equipped with auxiliaries									
iACTs indication auxiliary		Yes	Yes	Yes				Yes			
iACTp protection auxiliary	By yellow clips	No	No	Yes				No	Yes		
iACTc, iATEt control auxiliary	By yellow clips	No	No	Yes				No	Yes		
iACT24 control auxiliary		No	No	Yes (for contactors 230 V - 50 Hz)				No	Yes (for contactors 230 V - 50 Hz)		

Control

Remote control

Acti9 iCT contactors (cont.)

PB106115-39

Yellow clip
 ■ Clip-on system for electrical and mechanical connections between contactors ≥ 25 A and their auxiliaries

Insulated terminals IP20

Low noise

Mechanical contact position indicator

Manually-operated contactors have a 4-position selector switch on their front face:
 automatic operating mode
 temporary "ON" override
 permanent "ON" override: used to lock the contactor in the ON position during installation maintenance
 shutdown

Consistent with the entire Acti9 offer and with all types of lighting

Large circuit labeling area

Choice of 60 Hz contactors				
Contactor				Manually-operated contactors
16	25	40	63	40
Contactors that can be equipped with auxiliaries				
Yes				Yes
No	Yes			Yes
No	Yes			Yes
No	Yes			No

Control

Remote control

Acti9 iCT contactors (cont.)

Catalog numbers

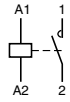
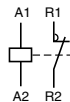
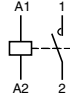
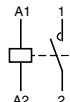
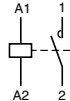
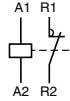
Acti9 iCT contactors - 50 Hz						
Type	Rating (In)		Control voltage (V AC) (50 Hz)	Contact		Width in 9 mm modules
1P	AC7a	AC7b				
 DB103373-5	16 A	6 A	12	1NO	A9C22011	2
			24	1NO	A9C22111	2
			48	1NO	A9C22211	2
			220	1NO	A9C22511	2
			230...240	1NO	A9C22711	2
	25 A	8.5 A	220	1NO	A9C20531	2
			230...240	1NO	A9C20731	2
2P						
 DB122915	16 A	6 A	12	2NO	A9C22012	2
			24	2NO	A9C22112	2
			48	2NO	A9C22212	2
			220	2NO	A9C22512	2
			230...240	2NO	A9C22712	2
 DB103377-11			12	1NO+1NC	A9C22015	2
			24	1NO+1NC	A9C22115	2
			220	1NO+1NC	A9C22515	2
			230...240	1NO+1NC	A9C22715	2
 DB103375-10	20 A	-	230...240	2NO	A9C22722	2
	25 A	8.5 A	24	2NO	A9C20132	2
			48	2NO	A9C20232	2
			220	2NO	A9C20532	2
			230...240	2NO	A9C20732	2
			220	2NC	A9C20536	2
	230...240	2NC	A9C20736	2		
40 A	15 A	220...240	2NO	A9C20842	4	
63 A	20 A	24	2NO	A9C20162	4	
		220...240	2NO	A9C20862	4	
100 A (*)	-	220...240	2NO	A9C20882	6	
3P						
 DB103378-14	16 A	6 A	220...240	3NO	A9C22813	4
	25 A	8.5 A	220...240	3NO	A9C20833	4
	40 A	15 A	220...240	3NO	A9C20843	6
	63 A	20 A	220...240	3NO	A9C20863	6
4P						
 DB122916	16 A	6 A	24	4NO	A9C22114	4
			220...240	4NO	A9C22814	4
			220...240	2NO+2NC	A9C22818	4
	20 A	-	220...240	4NO	A9C22824	4
	25 A	8.5 A	24	4NO	A9C20134	4
220...240			4NO	A9C20834	4	
24			4NC	A9C20137	4	
220...240			4NC	A9C20837	4	
40 A	15 A	220...240	2NO+2NC	A9C20838	4	
		220...240	4NO	A9C20844	6	
63 A	20 A	220...240	4NC	A9C20847	6	
		24	4NO	A9C20164	6	
		220...240	4NO	A9C20864	6	
		24	4NC	A9C20167	6	
220...240			4NC	A9C20867	6	
			220...240	2NO+2NC	A9C20868	6
			220...240	3NO+1NC	A9C20869	6
100 A (*)	-	220...240	4NO	A9C20884	12	

(*) do not use for lighting applications

Control

Remote control

Acti9 iCT contactors (cont.)

Catalog numbers

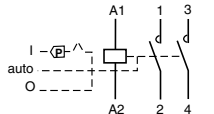
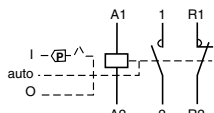
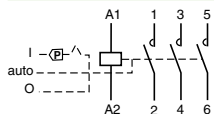
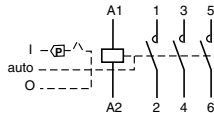
Acti9 iCT manual control contactor 50 Hz						Width in 9 mm modules	
Type	Rating (In)		Control voltage (V AC) (50 Hz)	Contact	Catalog number		
	AC7a	AC7b					
 DB106317-24	16 A	6 A	220	2NO	A9C23512	2	
			230...240	2NO	A9C23712	2	
			220	1NO+1NC	A9C23515	2	
			230...240	1NO+1NC	A9C23715	2	
	 DB106318-27	25 A	8,5 A	24	2NO	A9C21132	2
				220	2NO	A9C21532	2
		40 A	15 A	24	2NO	A9C21142	2
				220...240	2NO	A9C21842	4
63 A	20 A	24	2NO	A9C21162	4		
		220...240	2NO	A9C21862	4		
 DB106319-27	25 A	8,5 A	220...240	3NO	A9C21833	4	
	40 A	15 A	220...240	3NO	A9C21843	6	
 DB106320-31	25 A	8,5 A	24	4NO	A9C21134	4	
			220...240	4NO	A9C21834	4	
	40 A	15 A	24	4NO	A9C21144	6	
			220...240	4NO	A9C21844	6	
	63 A	20 A	24	4NO	A9C21164	6	
			220...240	4NO	A9C21864	6	

Control

Remote control

Acti9 iCT contactors (cont.)

Catalog numbers

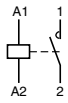
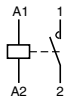
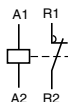
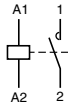
Acti9 iCT contactors - 60 Hz						
Type						Width in 9 mm modules
1P 	Rating (In)		Control voltage (V AC) (60 Hz)	Contact	Catalog number	
	AC7a	AC7b				
	25 A	8.5 A	127	1NO	A9C20431	2
			220...240	1NO	A9C20631	2
2P 	16 A	6 A	127	1NO+1NC	A9C22415	2
			220...240	1NO+1NC	A9C22615	2
	25 A	8.5 A	127	2NO	A9C20432	2
			220...240	2NO	A9C20632	2
	40 A	15 A	127	2NC	A9C20436	2
			220...240	2NC	A9C20636	2
		127	2NO	A9C20442	4	
		220...240	2NO	A9C20642	4	
3P 	25 A	8.5 A	127	3NO	A9C20433	4
			220...240	3NO	A9C20633	4
	40 A	15 A	127	3NO	A9C20443	6
			220...240	3NO	A9C20643	6
	63 A	20 A	127	3NO	A9C20463	6
			220...240	3NO	A9C20663	6

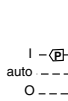
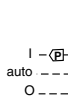
Acti9 iCT manual control contactor 60 Hz						
Type						Width in 9 mm modules
2P 	Rating (In)		Control voltage (V AC) (60 Hz)	Contact	Catalog number	
	AC7a	AC7b				
	40 A	15 A	127	2NO	A9C21442	4
			220...240	2NO	A9C21642	4



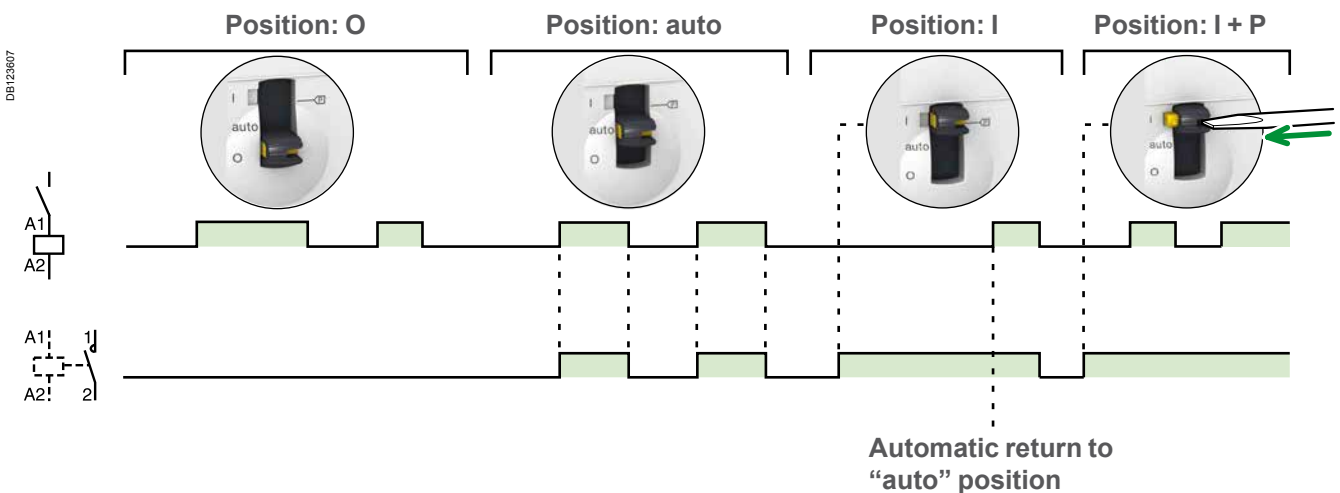



Operation (Manual control contactor)

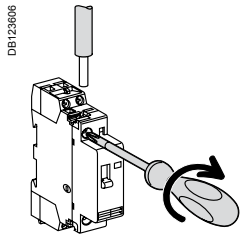





Control Remote control Acti9 iCT contactors (cont.)

Connection

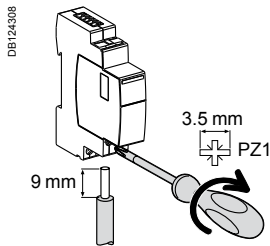



Type	Circuit	Rating	Length tripping	Tightening torque	Copper cables		
					Rigid	Flexible or with ferrule	
Acti9 iCT	PZ1: 4 mm	Control	16 - 100 A	9 mm	0.8 N.m		
		Power	16 and 25 A				
	PZ2: 6 mm	40 A - 63 A	14 mm	3.5 N.m			
iACTs, iACTp, iACTc, iATEt	PZ1: 4 mm	-	-	9 mm	0.8 N.m		

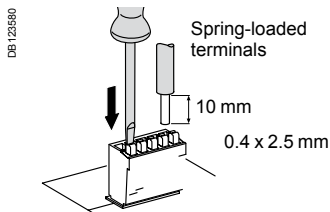

Type	Terminals	Tightening torque	Copper cables		
			Rigid	Flexible	Flexible or with ferrule
iACT24	Power supply (N/P) Input (Y1/Y2)	1 N.m			

Ti24 connector connection



Type	Catalog numbers	Copper cables	
		Rigid	Flexible
Ti24 Interface	A9XC2412		

Ti24 prefabricated cables connection

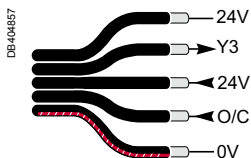

Type	Catalog numbers	Length
Connection for Acti9 Smartlink		
6 short prefabricated	A9XCAS06	100 mm
6 medium-sized prefabricated	A9XCAM06	160 mm
6 long prefabricated	A9XCAL06	870 mm
Connection for PLC type terminals		
6 long prefabricated on a single side	A9XCAU06	870 mm

Acti9 iCT contactors (cont.)

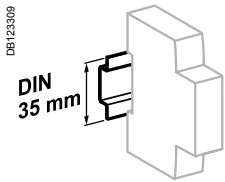

Clip on DIN rail 35 mm.

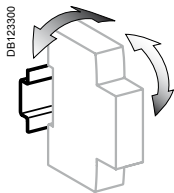

± 30° vertical.

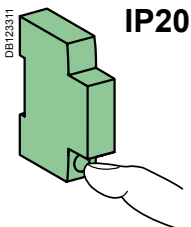

IP20

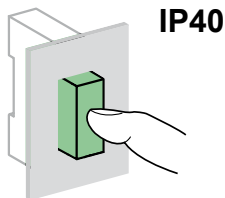

IP40

Technical data

Power circuit		
Voltage rating (Ue)	1P, 2P	250 V AC
	3P, 4P	400 V AC
Frequency	50 Hz or 60 Hz	
Type of load	See module CA908026	
Endurance (O-C)		
Electrical	100,000 cycles	
Maximum number of switching operations per day	100	
Additional characteristics		
Insulation voltage (Ui)	440 V AC	
Pollution degree	2	
Rated impulse withstand voltage (Uimp)	2.5 kV (4 kV for 12/24/48 V AC)	
Degree of protection (IEC 60529)	Device only	IP20
	Device in modular enclosure	IP40
Operating temperature	-5°C to +60°C	
Storage temperature	-40°C to +70°C	
Tropicalization (IEC 60068-2-30)	Treatment 2 (relative humidity 95 % at 55°C)	
ELSV compliance (Extra Low Safety Voltage) for 12/24/48 V AC versions		
The product control conforms to the SELV (safety extra low voltage) requirements		

Temperature derating table

Acti9 iCT	Ambient temperature (°C)		
Rating (A)	≤ 40	50	60
63	63	59.8	50
40	40	38	32
25	25	23.8	20
16	16	15.2	12.8

If multiple iCTs side by side: install spacer and apply 0.8 coefficient on upper current values.

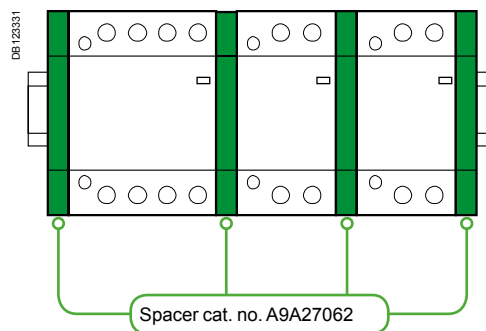

Control

Remote control

Acti9 iCT contactors (cont.)

Mounting accessories

7	Sealable screw shields for top and bottom	3P, 4P 25 A	A9A15921
		2P 40/63 A	A9A15922
		3P, 4P 40/63 A	A9A15923
8	9 mm spacer		A9A27062
9	Yellow clips		A9C15415
10	Clip-on terminal markers	see module	CA907001

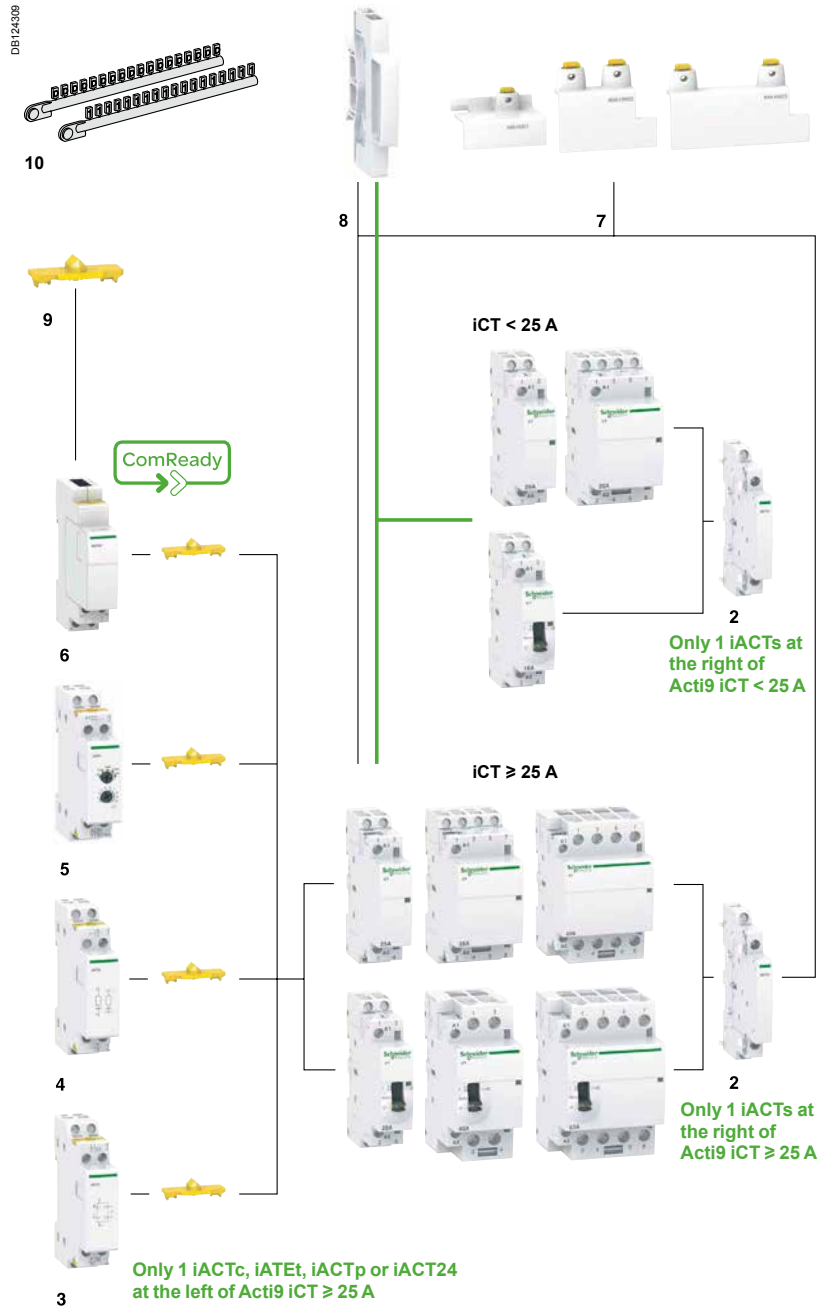

Auxiliaries

Indication			
2	Acti9 iACTs	1NO + 1NC	A9C15914
		1CO	A9C15915
		2NO	A9C15916
Double control inputs			
3	Acti9 iACTc	230 V AC	A9C18308
		24 V AC	A9C18309
Coil suppression blocs			
4	Acti9 iACTp	12...48 V AC	A9C15919
		48...127 V AC	A9C15918
		220...240 V AC	A9C15920
Time delay			
5	Acti9 iATEt	24...240 V AC	A9C15419
Control and indication			
6	Acti9 iACT24	230 V AC	A9C15924



Acti9 iCT contactors

Electrical auxiliaries for Acti9 iCT

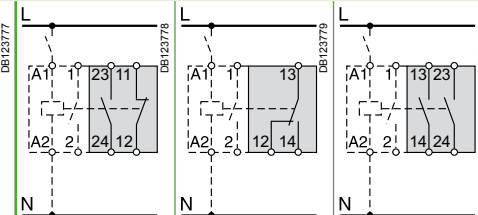
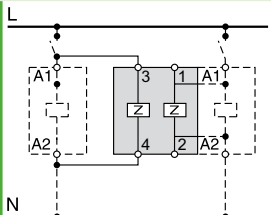
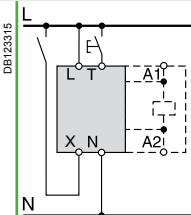
	Indication			Protection			Control	
Auxiliaries	Acti9 iACTs			Acti9 iACTp			Acti9 iACTc	
Type	Indication			Interference filterin			Impulse/latched control	
	With Open/Close auxiliary contact			2 protection circuits				
								
Function	<ul style="list-style-type: none"> This auxiliary allows indication of the "open" or "closed" position of the contactor power contacts 			<ul style="list-style-type: none"> This auxiliary is an interference suppressor which limits overvoltages on the control circuit 			<ul style="list-style-type: none"> This auxiliary, combined with contactors, enables them to be controlled by 2 order types: <ul style="list-style-type: none"> impulse order for local control (input T) latched order for centralised control (input X) the last order received takes priority 	
Wiring diagrams								
Mounting	<ul style="list-style-type: none"> Mounted to the right of Acti9 iCT 			<ul style="list-style-type: none"> Mounted to the left of Acti9 iCT by yellow clips⁽¹⁾ By wires 			<ul style="list-style-type: none"> Mounted to the left of Acti9 iCT by yellow clips⁽¹⁾ 	
Use				<ul style="list-style-type: none"> The iACTp has 2 separate and identical circuits, allowing it to be combined with 2 different one on the Acti9 iCT the other by wires 			<ul style="list-style-type: none"> Mains power outages: <ul style="list-style-type: none"> < 70 ms: keeps its initial status > 80 ms: reset put back into operation by manual operation on input X or T. Minimum impulse duration: 250 ms 	
Catalog numbers	A9C15914	A9C15915	A9C15916	A9C15918	A9C15919	A9C15920	A9C18308	A9C18309
Technical specifications								
Control voltage (Ue)	V AC	24...240		48...127	12...48	220...240	230...240	24...48
	V DC	24...130		-			-	
Control voltage frequency	Hz	50/60		50/60			50/60	
Width in 9 mm modules		1		2			2	
Auxiliary contact (breaking capacity)		<ul style="list-style-type: none"> Minimum: 10 mA at 24 V DC/AC Maximum: <ul style="list-style-type: none"> 5 A at 230 V AC, AC12 2 A at 230 V AC, AC15 1 A at 130 V DC, DC13 		-			-	
Number of contacts		1NO + 1NC	1CO	2NO	-			-
Operating temperature	°C	-5°C to +50°C		-			-	
Storage temperature	°C	-40°C to +70°C		-			-	
Consumption		-		-			OFF load: 3 VA Inrush ⁽²⁾ : 2 VA Holding ⁽²⁾ : 0.2 VA	

(1) Electrical and mechanical link.

(2) Maximum consumption of all contactors controlled

Acti9 iCT contactors

Electrical auxiliaries for Acti9 iCT (cont.)

Control (cont.)

Acti9 iATEt

Time delay

PE106125-34



■ This auxiliary is used to time delay for Acti9 iCT and iTL. According to cabling, there are 5 possible time delay types:

- 1 for iTL
- 4 for iCT.

Function type A: late closing

■ Delay energizing of contactor.

Function type B: time delay

■ Energize the contactor by closing a push button.
■ The time delay starts as soon as the control contacts are closed.

Function type C: late opening

■ Energize the contactor by closing a push button.
■ The time delay starts when the control contacts are opened.

Function type H: fixed time operation

■ Operate the contactor for a pre-determined time from the moment of energizing.

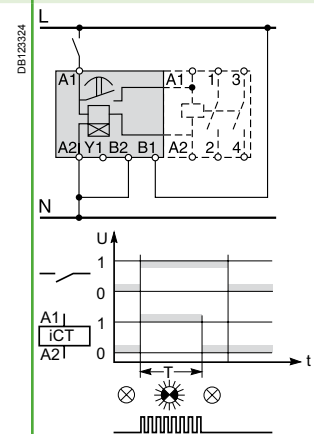
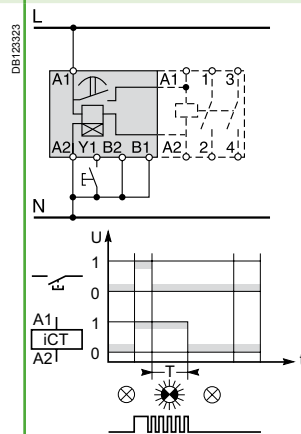
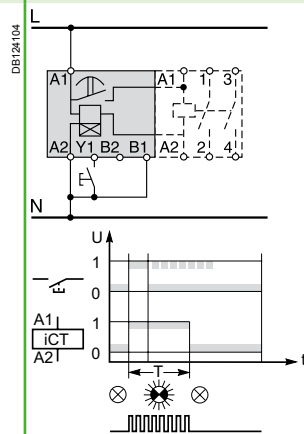
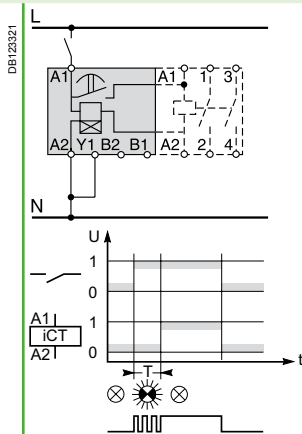

■ Mounted to the left of Acti9 iCT by yellow clips⁽¹⁾

A9C15419

24...240

24...110

50/60

2

-

-

-

-20°C to +50°C

-40°C to +80°C

Off-load: 5 VA
Inrush⁽²⁾: 3 A
Holding⁽²⁾: 0.2 A

Acti9 iCT contactors

Electrical auxiliaries for Acti9 iCT (cont.)

Control and indication

Auxiliary	Acti9 iACT24
Type	Control and indication 24 V DC

With Ti24 connector



Function

- This auxiliary allows a contactor to be interfaced with the Acti9 Smartlink interface or a programmable logic controller (PLC) in 24 V DC (control, O/C indication)
- 230 V AC control

Wiring diagrams

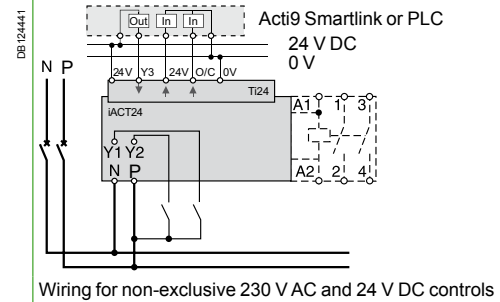
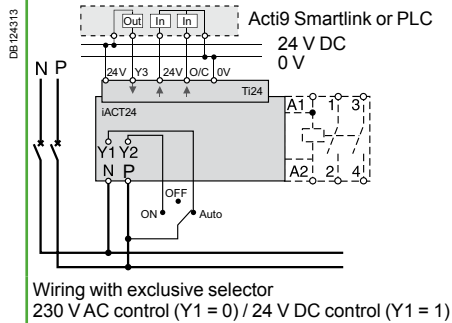

Mounting

- To the left of the Acti9 iCT contactor using the yellow clips ⁽¹⁾.
- When an iACT24 is used, the A1/A2 terminals of the contactors should not be wired. Only the yellow clips integral with the iACT24 should be used for connection to the coil.

Utilization

- 230 V AC interface:
 - Y1: enabling of 24 V DC control (Y1 = 1) or inhibition of 24 V DC control (Y1 = 0).
 - Y2: 230 V pulse control
- "Ti24" 24 V DC interface:
 - Y3: 24 V DC control of Acti9 iCT closing on rising edge and opening on falling edge
 - reading of the contactor status (opened or closed) from the position of the integrated O/C auxiliary contact
 - monitoring of connection of the "Ti24" terminal block by the upstream system (PLC, supervision system) via the 24 V terminal (in the centre of the Ti24 terminal block)





Catalog numbers	A9C15924
------------------------	-----------------

Technical specification	
Control voltage (Ue)	V AC 230, +10 %, -15 % (Y2) V DC 24, ± 20 % (Y3)
Control voltage frequency	Hz 50/60
Insulation voltage (Ui)	V AC 250
Rated impulse withstand voltage (Uimp)	kV 8 (OVC IV)
Pollution degree	3
Degree of protection	IP20B device only IP40 device in modular enclosure
Width in 9 mm modules	2
Auxiliary contact (O/C) Ti24	24 V DC protected output, min. 2 mA, max. 100 mA
Contact	1 O/C operating category AC 14
Operating temperature	°C -25°C to +60°C
Storage temperature	°C -40°C to +80°C
Consumption	<1 W
Standard	IEC/EN 60947-5-1

(1) Mechanical and electrical link.

Acti9 iCT contactors

Accessories for Acti9 iCT

Security					
Accessories	Sealable screw shields			Yellow clips	Spacer
 PB104485-15	 PB104486-15	 PB104487-15	 PB106143-10	 PB104483-40	
Function					
<ul style="list-style-type: none"> Designed to cover terminals to avoid contact with device screws. Allow sealing 					
<ul style="list-style-type: none"> For Acti9 iCT: 3P, 4P - 25 A 		<ul style="list-style-type: none"> For Acti9 iCT: 2P - 40/63 A 	<ul style="list-style-type: none"> For Acti9 iCT: 3P, 4P - 40/63 A 	<ul style="list-style-type: none"> Ensure the mechanical and/or electrical link between contactors and their auxiliaries. 	<ul style="list-style-type: none"> For Acti9 iCT: ≥ 25 A
<ul style="list-style-type: none"> Required to reduce temperature rise of modular devices installed side by side. Recommended to separate electronic devices (thermostat, programmable clock, etc.) from electromechanical devices (relays, contactors). 					
Set of	10 upstream / 10 downstream			10	5
Catalog numbers	A9A15921	A9A15922	A9A15923	A9C15415	A9A27062
Technical specification					
Width in 9 mm modules	4	4	6	–	1
Number of poles	3P, 4P	2P	3P, 4P	–	–

Acti9 iCT contactors

Technical advice for Acti9 iCT (cont.)



Operation of the iACT24

O/C 24 V DC output

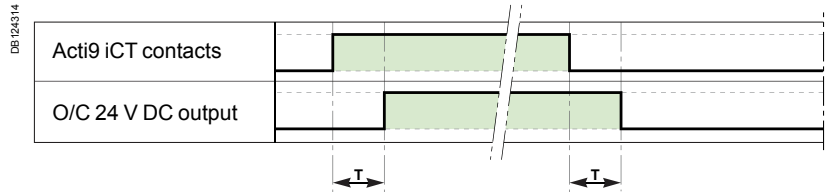

	Parameter	Min	Max
T	Time delay between iACT24 closing and indication	100 ms	200 ms

- Minimum duration of 230 V AC pulse (Y2): 200 ms.
- 30 iACT24 closing or opening actuations are authorized per minute: Minimum time delay between 2 actuations on the iACT4 via Y1, Y2, Y3 (closing or opening of the Acti9 iCT coil): 220 ms.
- 10 closing or opening actuations spaced 440 milliseconds apart are authorized following no loading of the iACT24 during a period of 20 seconds.

Wiring with exclusive selector 230 V AC control (Y1 = 0) / 24 V DC control (Y1 = 1)

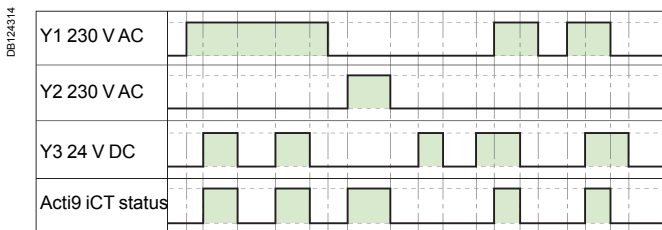
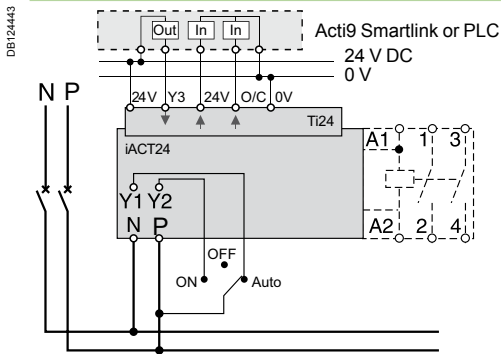

Wiring for non-exclusive 230 V AC and 24 V DC controls

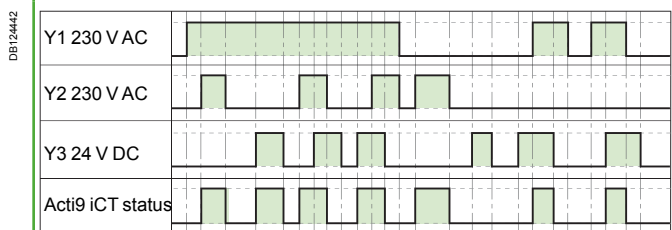
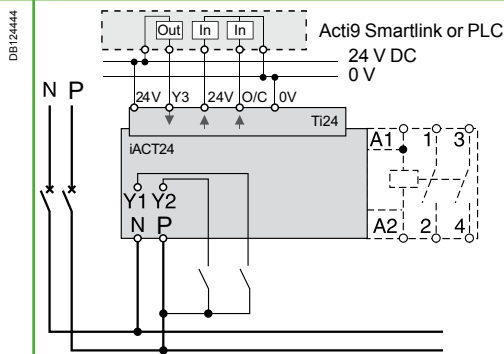

Acti9 iCT contactors

Technical advice for Acti9 iCT (cont.)

Consumption

Acti9 iCT contactors - 50 Hz									
Type									
1P	Rating (In)		Control voltage (V AC) (50 Hz)	Consumption		Max. power			
	AC7a	AC7b		Holding	Inrush				
1P	16 A	5 A	12	3.8 VA	15 VA	1.3 W	A9C22011		
			24	3.8 VA	15 VA	1.3 W	A9C22111		
			48	3.8 VA	15 VA	1.3 W	A9C22211		
			220	3.8 VA	15 VA	1.3 W	A9C22511		
			230...240	2.7 VA	9.2 VA	1.2 W	A9C22711		
	25 A	8.5 A	220	3.8 VA	15 VA	1.3 W	A9C20531		
			230...240	2.7 VA	9.2 VA	1.2 W	A9C20731		
			2P						
			16 A	5 A	12	3.8 VA	15 VA	1.3 W	A9C22012
					24	3.8 VA	15 VA	1.3 W	A9C22112
48	3.8 VA	15 VA			1.3 W	A9C22212			
220	3.8 VA	15 VA			1.3 W	A9C22512			
230...240	2.7 VA	9.2 VA			1.2 W	A9C22712			
12	3.8 VA	15 VA			1.3 W	A9C22015			
20 A	6.4 A	24	3.8 VA	15 VA	1.3 W	A9C22115			
		220	3.8 VA	15 VA	1.3 W	A9C22515			
		230...240	2.7 VA	9.2 VA	1.2 W	A9C22715			
25 A	8.5 A	24	3.8 VA	15 VA	1.3 W	A9C20132			
		48	3.8 VA	15 VA	1.3 W	A9C20232			
		220	3.8 VA	15 VA	1.3 W	A9C20532			
		230...240	2.7 VA	9.2 VA	1.2 W	A9C20732			
		220	3.8 VA	15 VA	1.3 W	A9C20536			
40 A	15 A	230...240	2.7 VA	9.2 VA	1.2 W	A9C20736			
		220...240	4.6 VA	34 VA	1.6 W	A9C20842			
63 A	20 A	24	4.6 VA	34 VA	1.6 W	A9C20162			
		220...240	4.6 VA	34 VA	1.6 W	A9C20862			
100 A (*)	-	220...240	6.5 VA	53 VA	2.1 W	A9C20882			
3P									
3P	16 A	5 A	220...240	4.6 VA	34 VA	1.6 W	A9C22813		
	25 A	8.5 A	220...240	4.6 VA	34 VA	1.6 W	A9C20833		
	40 A	15 A	220...240	6.5 VA	53 VA	2.1 W	A9C20843		
	63 A	20 A	220...240	6.5 VA	53 VA	2.1 W	A9C20863		
4P									
4P	16 A	5 A	24	4.6 VA	34 VA	1.6 W	A9C22114		
			220...240	4.6 VA	34 VA	1.6 W	A9C22814		
			220...240	4.6 VA	34 VA	1.6 W	A9C22818		
	20 A	6.4 A	220...240	4.6 VA	34 VA	1.6 W	A9C22824		
			25 A	8.5 A	24	4.6 VA	34 VA	1.6 W	A9C20134
	220...240	4.6 VA	34 VA		1.6 W	A9C20834			
	24	4.6 VA	34 VA		1.6 W	A9C20137			
	220...240	4.6 VA	34 VA		1.6 W	A9C20837			
	220...240	4.6 VA	34 VA		1.6 W	A9C20838			
	40 A	15 A	220...240	6.5 VA	53 VA	2.1 W	A9C20844		
			220...240	6.5 VA	53 VA	2.1 W	A9C20847		
	63 A	20 A	24	6.5 VA	53 VA	2.1 W	A9C20164		
220...240			6.5 VA	53 VA	2.1 W	A9C20864			
24			6.5 VA	53 VA	2.1 W	A9C20167			
220...240			6.5 VA	53 VA	2.1 W	A9C20867			
220...240			6.5 VA	53 VA	2.1 W	A9C20868			
100 A (*)	-	220...240	6.5 VA	53 VA	2.1 W	A9C20869			
		220...240	13 VA	106 VA	4.2 W	A9C20884			

(*) do not use for lighting applications

Acti9 iCT contactors

Technical advice for Acti9 iCT (cont.)

Consumption

Acti9 iCT manual control contactor 50 Hz

Type							
2P	Rating (In)		Control voltage (V AC) (50 Hz)	Consumption		Max. power	
	AC7a	AC7b		Holding	Inrush		
16 A	5 A	220	2.7 VA	9.2 VA	1.2 W	A9C23512	
			2.7 VA	9.2 VA	1.2 W	A9C23712	
			3.8 VA	15 VA	1.3 W	A9C23515	
			2.7 VA	9.2 VA	1.2 W	A9C23715	
	25 A	8.5 A	24	3.8 VA	15 VA	1.3 W	A9C21132
			220	2.7 VA	9.2 VA	1.2 W	A9C21532
			2.7 VA	9.2 VA	1.2 W	A9C21732	
	40 A	15 A	24	4.6 VA	34 VA	1.6 W	A9C21142
220...240			4.6 VA	34 VA	1.6 W	A9C21842	
63 A	20 A	24	4.6 VA	34 VA	1.6 W	A9C21162	
		220...240	4.6 VA	34 VA	1.6 W	A9C21862	
3P							
25 A	8.5 A	220...240	4.6 VA	34 VA	1.6 W	A9C21833	
		40 A	15 A	220...240	6.5 VA	53 VA	2.1 W
4P							
25 A	8.5 A	24	4.6 VA	34 VA	1.6 W	A9C21134	
		220...240	4.6 VA	34 VA	1.6 W	A9C21834	
40 A	15 A	24	6.5 VA	53 VA	2.1 W	A9C21144	
		220...240	6.5 VA	53 VA	2.1 W	A9C21844	
63 A	20 A	24	6.5 VA	53 VA	2.1 W	A9C21164	
		220...240	6.5 VA	53 VA	2.1 W	A9C21864	

Acti9 iCT contactors - 60 Hz

Type							
1P	Rating (In)		Control voltage (V AC) (60 Hz)	Consumption		Max. power	
	AC7a	AC7b		Holding	Inrush		
25 A	8.5 A	127	3.8 VA	15 VA	1.3 W	A9C20431	
		220 ...240	2.7 VA	9.2 VA	0.9 W	A9C20631	
2P							
16 A	5 A	127	3.8 VA	15 VA	1.3 W	A9C22415	
		220...240	2.7 VA	9.2 VA	0.9 W	A9C22615	
25 A	8.5 A	127	3.8 VA	15 VA	1.3 W	A9C20432	
		220...240	2.7 VA	9.2 VA	0.9 W	A9C20632	
		127	3.8 VA	15 VA	1.3 W	A9C20436	
		220...240	2.7 VA	9.2 VA	0.9 W	A9C20636	
40 A	15 A	127	4.6 VA	34 VA	1.6 W	A9C20442	
		220...240	4.6 VA	34 VA	1.6 W	A9C20642	
3P							
25 A	8.5 A	127	4.6 VA	34 VA	1.6 W	A9C20433	
		220...240	4.6 VA	34 VA	1.6 W	A9C20633	
40 A	15 A	127	6.5 VA	53 VA	2.1 W	A9C20443	
		220...240	6.5 VA	53 VA	2.1 W	A9C20643	
63 A	20 A	127	6.5 VA	53 VA	2.1 W	A9C20463	
		220...240	6.5 VA	53 VA	2.1 W	A9C20663	

Control
Remote control

Acti9 iCT contactors

Dimensions for Acti9 iCT

Dimensions (mm)

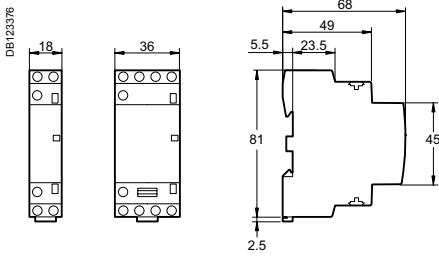

Acti9 iCT 16/25 A

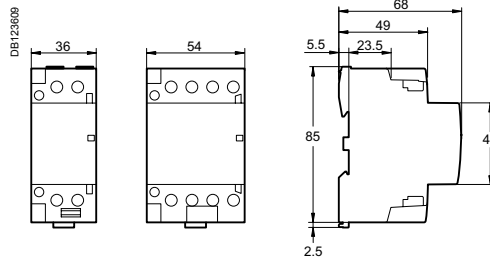

Acti9 iCT 40/63 A

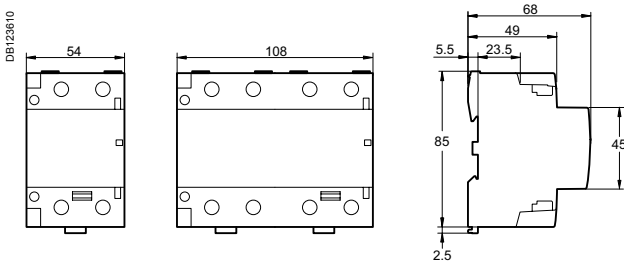

Acti9 iCT 100 A

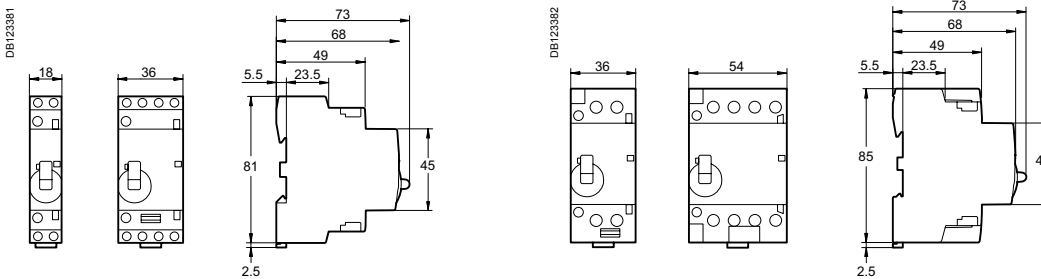

Acti9 iCT manual control contactor 16/25 A

Acti9 iCT manual control contactor 40/63 A

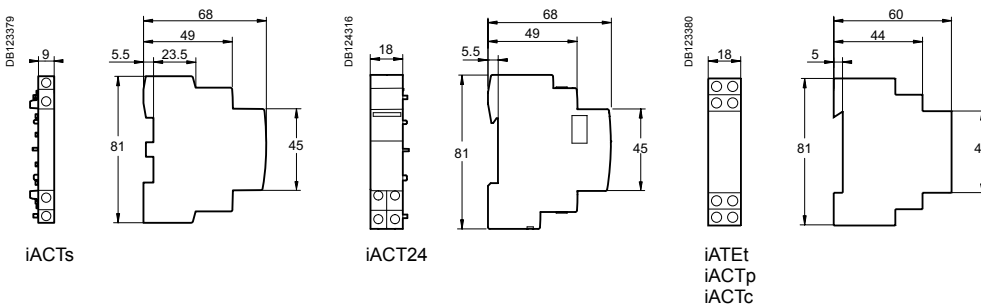

iACTs

iACT24

iATEt
iACTp
iACTc

Control Remote control iTl impulse relays

DB12399
CEBEC 12
DB116819
VDE
iTL, iTLI, iTLs, iTLc, iTLm
Country approval pictograms

IEC/EN 60669-2-2
iTlS: IEC/EN 60947-5-1

> Impulse relays



iTL
■ The impulse relays are used to control, by means of pushbuttons, lighting circuits consisting of:
□ incandescent lamps, low-voltage halogen lamps, etc. (resistive loads)
□ fluorescent lamps, discharge lamps, etc. (inductive loads)

> Remote indication



iTLs
■ Allows remote indication of its operating state (open/closed)



Indication iATLs
■ Allows remote indication of the associated impulse relay

> Centralised control



iTLc
■ Allows centralised control of a group of TLc impulse relays, whilst at the same time retaining local impulse-type control



Centralised control iATLc
■ Used for centralised control, thanks to a "pilot line", of a group of impulse relays controlling separate circuit, while at the same time maintaining local individual control of each impulse relay

> Latched control



iTLm
■ Operated by latched orders from a changeover contact (switch, time switch, thermostat). Manual control does not work



Latched control iATLm
■ Controls the associated impulse relay by latched orders from a changeover contact

Impulse relays

Control

Remote control

iTL impulse relays (cont.)

Impulse relays are used:

- Closing of the impulse relay pole(s) is triggered by an impulse on the coil.
- Having two stable mechanical positions, the pole(s) will be opened by the next impulse. Each impulse received by the coil reverses the position of the pole(s).
- Can be controlled by an unlimited number of pushbuttons.
- Zero energy consumption.



Changeover contact iTLi

- This impulse relay has a changeover contact

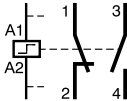

Extensions iETL

- Used to increase the number of impulse relay poles
- Can be installed on the iTL, iTLi, iTLc, iTLm and iTLs

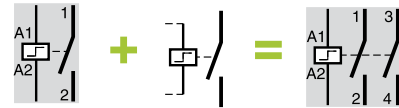

Centralised control + indication iATLc+s

- Used for centralised control, thanks to a "pilot line", of a group of impulse relays controlling separate circuit, while at the same time maintaining local individual control of each impulse relay
- Remote indication of the mechanical status of each relay



Control and indication 24 V DC iATL24

- Allows control and indication of a 230 V AC impulse relay from the Acti 9 Smartlink or by a PLC, by 24 V DC signals
- Also allows control by a pulsed signal



Multi-level centralised control iATLc+c

- Allows centralised control of a group of iTLc or "iTL + ATLc" impulse relays



Time delay iATE

- Combined with an impulse relay, it automatically disconnects the circuit after a preset time



Control iATLz

- Must be used when installing several illuminated PBs in parallel to control an impulse relay (prevents operating malfunctions)



Step by step control iATL4

- Allows step-by-step control of two circuits via a single pushbutton

Impulse relays auxiliaries

Specific auxiliaries

Control

Remote control

iTL impulse relays (cont.)

Mounting accessories

11	Yellow clips	A9C15415
12	9 mm spacer	A9A27062
13	Clip-on terminal markers	see module CA907001

DB 123631



Auxiliaries

Centralised control	Control voltage	Cat. no.
2 iATLc ^{(1), (3)}	24...240 V AC	A9C15404
Indication		
3 iATLs ⁽¹⁾	-	A9C15405
Centralised control + indication		
4 iATLc+s ⁽³⁾	24...240 V AC	A9C15409
Multi-level centralised control		
5 iATLc+c ^{(2), (3)}	24...240 V AC	A9C15410
Step by step control		
6 iATL4	230 V AC	A9C15412
Control by illuminated push-buttons		
7 iATLz	230...240 V AC	A9C15413
Latched control		
8 iATLm ⁽¹⁾	12...240 V AC	A9C15414
Time delay control		
9 iATEt ⁽⁴⁾	24...240 V AC	A9C15419
Control and indication		
10 iATL24	230 V AC	A9C15424



(1) The iATLc, iATLs and iATLm 9 mm auxiliaries must be mounted to the right of an impulse relay.
 (2) Connection by traditional cabling. The iATLc+c must be mounted to the right of an iATLc+s or an iATLc.
 (3) The centralised control functions (iTLc, iATLc, iATLc+s, iATLc+c) only operate on AC voltage networks.
 (4) iATEt: control voltage: 24...240 V AC, 24...110 V DC.

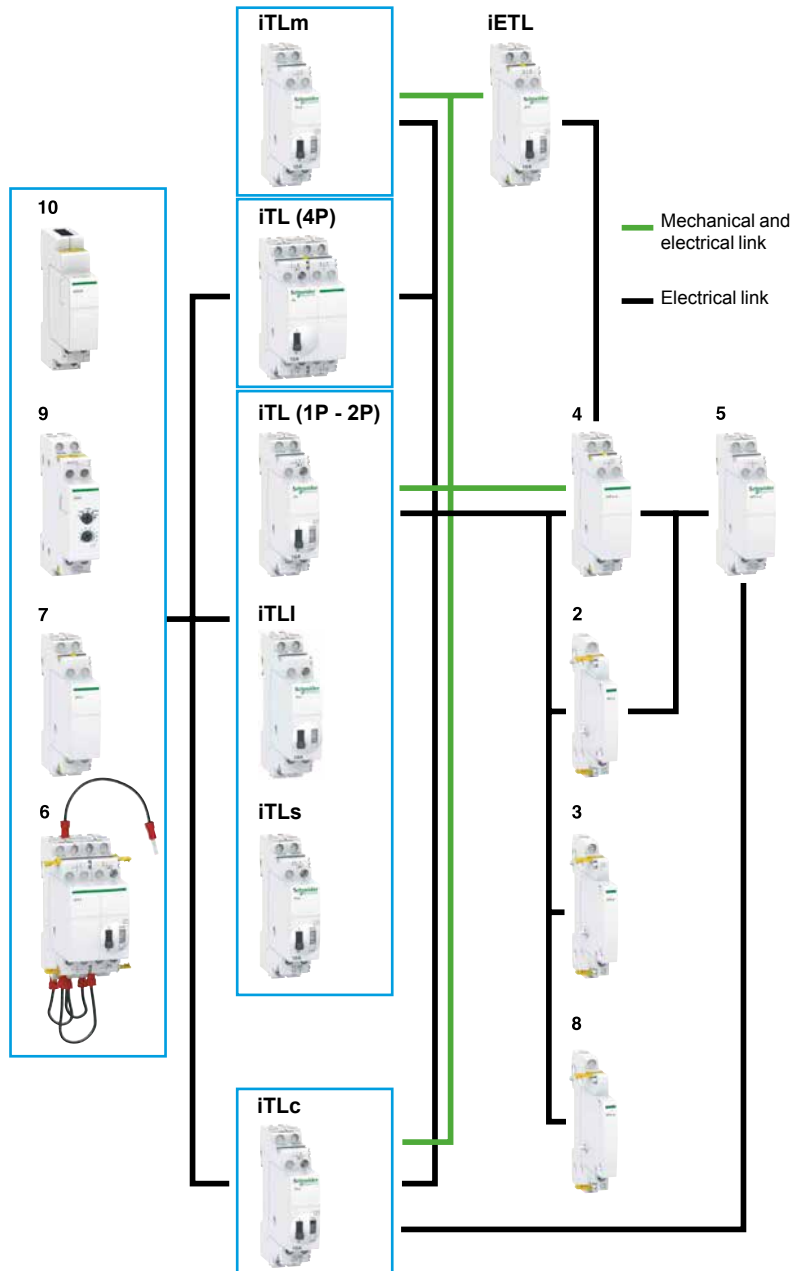

Control

Remote control

iTL impulse relays (cont.)

PE106128-41

Yellow clip

- A simple clip-on system for flexible auxiliaries combination and improved robustness
- For electrical and mechanical connections

■ Insulated terminals IP20

■ Large circuit labeling area

■ Consistent with the entire Acti 9 offer and with all types of lighting

■ Manual controls on front face: direct and priority manual control by O-I toggle

■ Mechanical contact position indicator

■ Disconnection of remote control by selector switch (except for 4P single-piece iTL) for maintenance operation

■ Built-in or optional auxiliary function: state indication, centralised control, latched control, control for illuminated pushbutton, step-by-step control, time delay



Control

Remote control

iTL impulse relays (cont.)

Auxiliaries choice in V AC and V DC

V AC		Choice impulse relays auxiliaries																		
Type		Standard iTL					Changeover iTLI					iTLc centralised control			iTLm control on latched order		iTLs remote indication			
Rating	A	16					32					16			16		16			
Control voltage (Uc)	V AC	230/240	130	48	24	12	230/240	230/240	130	48	24	12	230/240	48	24	230/240	230/240	48	24	
Auxiliaries																				
Extension																				
iETL		■	■	■	■	■	■	■	■	■	■	■	■	■	■	■	■	■	■	■
Centralised control + indication																				
iATLc+s		■	■	■	■	-	■	■	■	■	-	-	-	-	-	-	-	■	■	■
Centralised control																				
iATLc		■	■	■	■	-	■	■	■	■	-	-	-	-	-	-	-	■	■	■
Indication																				
iATLs		■	■	■	■	-	■	■	■	■	■	■	■	■	■	■	■	■	■	■
Multi-level centralised control																				
iATLc+c		■	■	■	■	-	■	■	■	■	-	■	■	■	-	-	-	■	■	■
Latched control																				
iATLm		■	■	■	■	■	■	■	■	■	■	-	-	-	-	-	-	■	■	■
Control for illuminated Pushbutton																				
iATLz		■	-	-	-	-	■	■	-	-	-	■	-	-	-	-	-	■	-	-
Step by step control																				
iATL4		■	-	-	-	-	■	■	-	-	-	■	-	-	-	-	-	■	-	-
Time delay control																				
iATET		■	■	■	■	-	■	■	■	■	-	-	-	-	-	-	-	■	■	■
Control and indication																				
iATL24		■	-	-	-	-	■	■	-	-	-	■	-	-	-	-	-	■	-	-

V DC		Choice impulse relays auxiliaries																		
Type		Standard iTL					Changeover iTLI					iTLc centralised control			iTLm control on latched order		iTLs remote indication			
Rating	A	16					32					16			16		16			
Control voltage (Uc)	V DC	110	48	24	12	6	110	110	48	24	12	6	-	-	-	110	110	24	12	
Auxiliaries																				
Extension																				
iETL		■	■	■	■	■	■	■	■	■	■	-	-	-	-	-	-	■	■	■
Indication																				
iATLs		■	■	■	■	-	■	■	■	■	■	-	-	-	-	-	-	■	■	■
Time delay control																				
iATET		■	■	■	-	-	■	■	■	■	-	-	-	-	-	-	-	■	■	-

Control

Remote control

iTL impulse relays (cont.)

Catalogue numbers

iTL impulse relays				
Type	1P	2P	3P	4P
	1 NO	2 NO	1 NO + 1 NO/NC + 1 NO	4 NO
				2 NO + 1 NO/NC + 1 NO
Rating (In)	Control voltage (Uc)			
	(V AC)	(V DC)		
	(50/60 Hz)			
16 A	12	6	A9C30011	A9C30012
	24	12	A9C30111	A9C30112
	48	24	A9C30211	A9C30212
	130	48	A9C30311	A9C30312
	230...240	110	A9C30811	A9C30812
Width in 9 mm modules			2	2
	1 NO	1 NO + 1 NO	1 NO + 1 NO + 1 NO	1 NO + 1 NO + 1 NO + 1 NO
32 A	230...240	110	A9C30831	A9C30831 + A9C32836
Width in 9 mm modules			2	4
			6	8

iTLI impulse relays			
Type	2P		
	1 NO + 1 NC		
Rating (In)	Control voltage (Uc)		
	(V AC)	(V DC)	
	(50/60 Hz)		
16 A	12	6	A9C30015
	24	12	A9C30115
	48	24	A9C30215
	130	48	A9C30315
	230...240	110	A9C30815
Width in 9 mm modules			2

iETL extensions for iTL and iTLI				
Type	1P	2P		
	1 NO	1 NO/NC + 1 NO		
Rating (In)	Control voltage (Uc)			
	(V AC)	(V DC)		
	(50/60 Hz)			
16 A	12	6	-	A9C32016
	24	12	-	A9C32116
	48	24	-	A9C32216
	130	48	-	A9C32316
	230...240	110	-	A9C32816
32 A	230...240	110	A9C32836	-
Width in 9 mm modules			2	2

Control
Remote control

iTL impulse relays (cont.)

iTLc , iTLm, iTLs with built-in auxiliary function

Catalogue numbers (cont.)

		iTLc impulse relay with centralised control	
Type		1P	3P
		1NO	1 NO + 1 NO/NC + 1 NO
Rating (In)	Control voltage (Uc) (V AC) (50/60 Hz)		
16 A	24	A9C33111	A9C33111 + A9C32116
	48	A9C33211	A9C33211 + A9C32216
	230...240	A9C33811	A9C33811 + A9C32816
Width in 9 mm modules		2	4

		iTLm impulse relay with latched control	
Type		1P	3P
		1NO	1 NO + 1 NO/NC + 1 NO
Rating (In)	Control voltage (Uc) (V AC) (50/60 Hz)		
16 A	230...240	A9C34811	A9C34811 + A9C32816
	230...240	A9C34811	A9C34811 + A9C32816
Width in 9 mm modules		2	4

		iTLs impulse relay with remote indication*	
Type		1P	3P
		1NO	1 NO + 1 NO/NC + 1 NO
Rating (In)	Control voltage (Uc)		
16 A	(V AC) (50/60 Hz)	(V DC)	
	24	12	A9C32111
	48	24	A9C32211
230...240		110	A9C32811
Width in 9 mm modules		2	4

(*) Short circuit protection device for indication contacts : 6 A gG fuse.

Control Remote control iTL impulse relays (cont.)

Connection

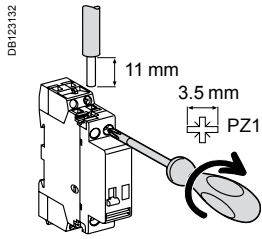

Type	Rating	Circuit	Tightening torque	Copper cables	
				Rigid or with ferrule	Flexible or with ferrule
iTL, iTLi, iTLc, iTLm, iTLs, iETL	16 A	Control	1 N.m		
		Power			
iTL, iETL	32 A	Control	1.2 N.m		
		Power			
iATLs, iATLc, iATLc+s, iATLc+c, iATLm, iATEt, iATL4, iATLz			1 N.m		

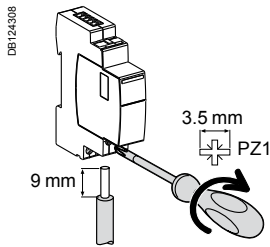

Type	Terminals	Tightening torque	Copper cables		
			Rigid	Flexible	Flexible or with ferrule
iATL24	Power supply (N/P) Input (Y1/Y2)	1 N.m			
			0.5 to 10 mm ² 2 x 0.5 to 2 x 2.5 mm ²	0.5 to 6 mm ² 2 x 0.5 to 2 x 2.5 mm ²	0.5 to 4 mm ² 2 x 0.5 to 2 x 2.5 mm ²

Ti24 connector connection

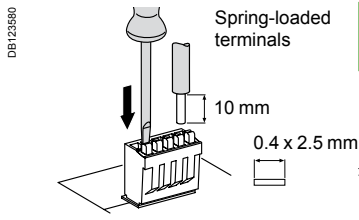

Type	Catalogue numbers	Copper cables	
		Rigid	Flexible
Ti24 interface	A9XC2412		
		1 x 0.5 to 1.5 mm ²	1 x 0.5 to 1.5 mm ²

Ti24 prefabricated cables connection

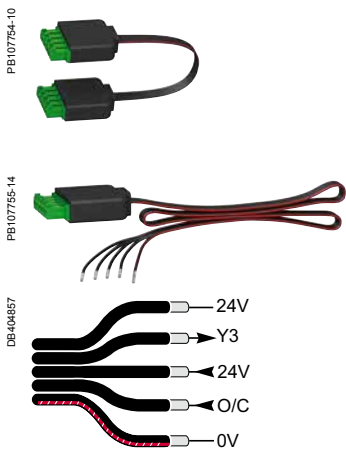

Type	Catalogue numbers	Length
Connection for Acti 9 Smartlink		
6 short prefabricated	A9XCAS06	100 mm
6 medium-sized prefabricated	A9XCAM06	160 mm
6 long prefabricated	A9XCAL06	870 mm
Connection for PLC type terminals		
6 long prefabricated on a single side	A9XCAU06	870 mm

iTL impulse relays (cont.)

Operation

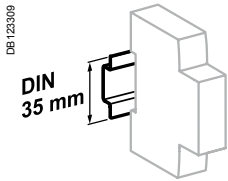
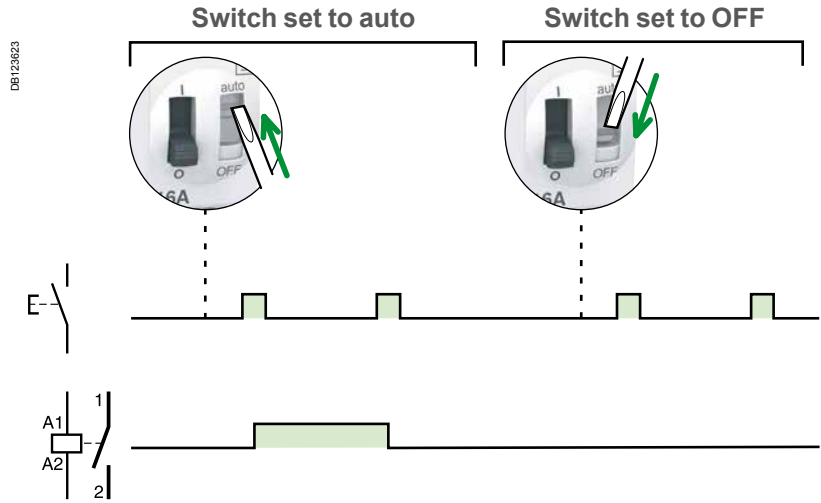

Clip on DIN rail 35 mm.

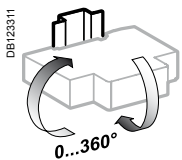

Indifferent position of installation.

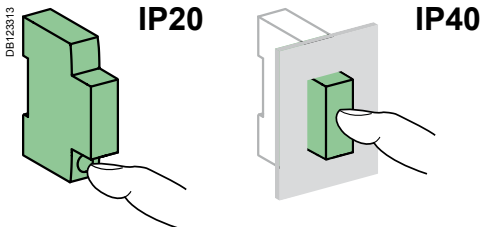



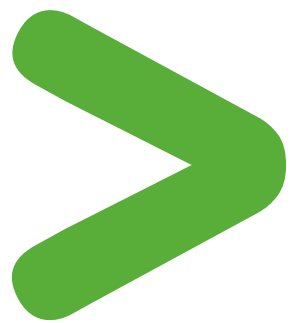

Technical data

Control circuit		iTL and iTL 16 A iTLc, iTLm, iTLs, iETL 16 A	iTL 32 A, iETL 32 A
Control voltage (Uc)	Tolerance at 50 Hz	+6 %, -15 %	
	Tolerance at 60 Hz	±6 %	
	Tolerance V DC	+6 %, -10 %	
Dissipated power (during the impulse)	1, 2, 3P: 19 VA	19 VA	
	4P: 38 VA		
Illuminated PB control	Max. current 3 mA (if > use an ATLz)		
Operating threshold	Min. 85 % of Un in conformance with IEC/EN60669-2-2		
Duration of the control order	50 ms to 1 s (200 ms recommended)		
Response time	50 ms		
Power circuit			
Voltage rating (Ue)	1P, 2P	24 ...250 V AC	
	3P, 4P	24...415 V AC	
Frequency	50 Hz or 60 Hz		
Maximum number of operations per minute	5		
Maximum number of switching operation a day	100		
Additional characteristics			
Insulation voltage (Ui)	440 V AC		
Pollution degree	3		
Rated impulse withstand voltage (Uimp)	6 kV		
Overvoltage category	IV		
Endurance (O-C)			
Electrical	200,000 cycles (AC21)	50,000 cycles (AC21)	
	100,000 cycles (AC22)	20,000 cycles (AC22)	
Other characteristics			
Degree of protection (IEC 60529)	Device only	IP20	
	Device in modular enclosure	IP40 Insulation class II	
Operating temperature	-20°C to +50°C		
Storage temperature	-40°C to +70°C		
Tropicalization (IEC 60068-1)	Treatment 2 (relative humidity 95 % at 55°C)		



iTL impulse relays (cont.)



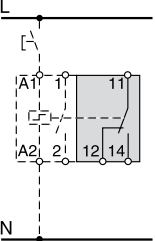
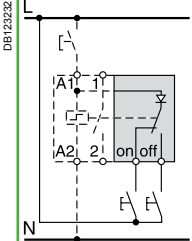
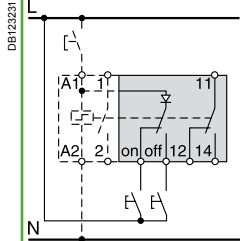
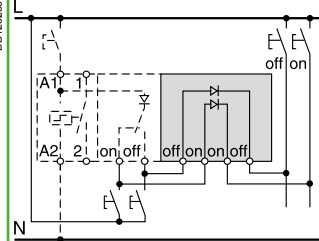

Electrical auxiliaries for iTL impulse relays

		Indication	Control		
Auxiliaries		iATLs	iATLc	iATLc+s	iATLc+c
Type		Indication	Centralised control	Centralised control + indication	Multi-level centralised control
					
Function		<ul style="list-style-type: none"> Allows remote indication of the associated impulse relay 	<ul style="list-style-type: none"> Used for centralised control, thanks to a "pilot line", of a group of impulse relays controlling separate networks, while at the same time maintaining local individual control of each impulse relay 	<ul style="list-style-type: none"> And for remote indication of the mechanical status of each relay 	<ul style="list-style-type: none"> Used to control the centralised controls of a number of impulse relay groups, while at the same time maintaining local individual control and centralised control by level
Wiring diagrams					
Mounting		<ul style="list-style-type: none"> Mounted to the right of iTL by yellow clips 	<ul style="list-style-type: none"> Mounted to the right of iTL by yellow clips 	<ul style="list-style-type: none"> Mounted to the right of iTL by yellow clips 	<ul style="list-style-type: none"> Without mechanical link with impulse relays and auxiliaries
Catalogue numbers		A9C15405	A9C15404	A9C15409	A9C15410
Technical specifications					
Control voltage (Uc)	V AC	–	24...240	24...240	24...240
	V DC	–	–	–	–
Control voltage frequency	Hz	–	50/60	50/60	50/60
Width in 9 mm modules		1	1	2	2
Auxiliary contact (breaking capacity)		<ul style="list-style-type: none"> Minimum: 10 mA at 24 V AC/DC Maximum (IEC 60947-5-1): <ul style="list-style-type: none"> 12...240 V AC 6 A 12...24 V DC 6 A 15...240 V AC 2 A 13...24 V DC 2 A 	–	<ul style="list-style-type: none"> Minimum: 10 mA at 24 V AC/DC Maximum (IEC 60947-5-1): <ul style="list-style-type: none"> 12...240 V AC 6 A 12...24 V DC 6 A 15...240 V AC 2 A 13...24 V DC 2 A 	–
Number of contacts		–	–	–	–
Operating temperature	°C	–20°C to +50°C	–	–	–
Storage temperature	°C	–40°C to +70°C	–	–	–

iTL impulse relays (cont.)

Electrical auxiliaries for iTL impulse relays (cont.)

Control

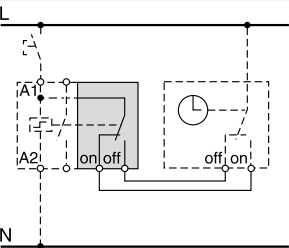
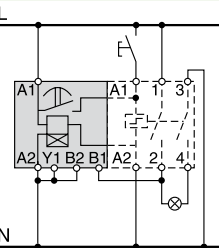
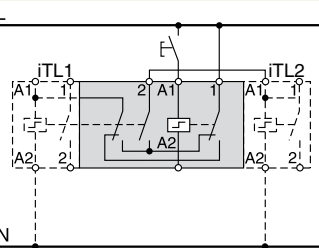
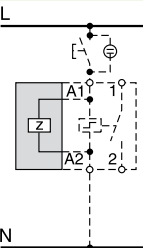
	iATLm	iATEt	iATL4	iATLz
	Latched control	Time delay	Step by step control	Control by illuminated push-buttons
				
	<ul style="list-style-type: none"> Combined with an impulse relay, it operates on latched orders 	<ul style="list-style-type: none"> Combined with an impulse relay, it automatically disconnects the circuit after a preset time 	<ul style="list-style-type: none"> Allows the step by step sequence over 2 circuits 	<ul style="list-style-type: none"> Used to control impulse relays by illuminated push-buttons, without operating risks
				
		<ul style="list-style-type: none"> 5 time setting ranges: <ul style="list-style-type: none"> 1 to 10 s 6 to 60 s 2 to 10 min 6 to 60 min 2 to 10 h 	<ul style="list-style-type: none"> The cycle is as follows: <ul style="list-style-type: none"> 1st impulse - iTL 1 closed, iTL 2 open 2nd impulse - iTL 1 open, iTL 2 closed 3rd impulse - iTL 1 and 2 closed 4th impulse - iTL 1 and 2 open 5th impulse - iTL 1 closed, iTL 2 open, etc 	<ul style="list-style-type: none"> Provide an iATLz when the current drawn up by the illuminated push-buttons is higher than 3 mA (this current is sufficient to keep the coils energised). Above this value, fit one extra iATLz per 3 mA. For example: for 7 mA, fit 2 iATLz
	<ul style="list-style-type: none"> Mounted to the right of iTL by yellow clips 	<ul style="list-style-type: none"> Mounted to the left of iTL by yellow clips 	<ul style="list-style-type: none"> Assembled between 2 impulse relays: according to the auxiliarisation table by yellow clips 	<ul style="list-style-type: none"> Mounted to the left of iTL by yellow clips
	A9C15414	A9C15419	A9C15412	A9C15413
	12...240	24...240	230	230...240
	—	24...110	—	—
	50/60	50/60	50/60	50/60
	1	2	4	2
	—	—	—	—
	—	—	—	—
	-20°C to +50°C	—	—	—
	-40°C to +70°C	—	—	—

iTL impulse relays (cont.)

Electrical auxiliaries for iTL impulse relays (cont.)

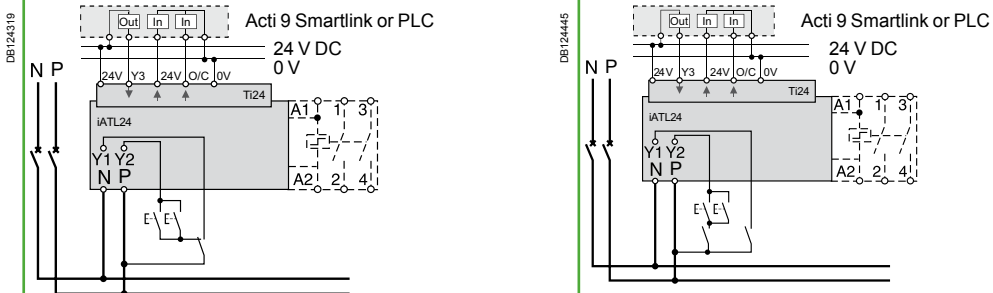
		Control and indication	
Auxiliaire		iATL24	
Type		Control and indication 24 V DC	
		With Ti24 connector	
			
Function		<ul style="list-style-type: none"> This auxiliary allows a impulse relay to be interfaced with the Acti 9 Smartlink interface or a programmable logic controller (PLC) in 24 V DC (control, O/C indication) 230 V AC control 	
Wiring diagrams			
		<p>Wiring with exclusive selector 230 V AC and 24 V DC controls</p> <p>Wiring for non-exclusive 230 V AC and 24 V DC controls</p>	
Mounting		<ul style="list-style-type: none"> To the left of the iTL impulse relay using the yellow clips⁽¹⁾. When an iATL24 is used, the A1/A2 terminals of the impulse relay should not be wired. Only the yellow clips integral with the iATL24 should be used for connection to the coil. 	
Utilization		<ul style="list-style-type: none"> 230 V AC interface: <ul style="list-style-type: none"> Y1: enabling of 24 V DC control (Y1 = 1) or inhibition of 24 V DC control (Y1 = 0). Y2: 230 V pulse control "Ti24" 24 V DC interface: <ul style="list-style-type: none"> Y3: 24 V DC control of iTL closing on rising edge and opening on falling edge reading of the impulse relay status (opened or closed) from the position of the integrated O/C auxiliary contact monitoring of connection of the "Ti24" terminal block by the upstream system (PLC, supervision system) via the 24 V terminal (in the centre of the Ti24 terminal block) 	
Catalogue numbers		A9C15424	
Technical specification			
Control voltage (Uc)	V AC	230, +10 %, -15 % (Y2)	
	V DC	24, ± 20 % (Y3)	
Control voltage frequency	Hz	50/60	
Insulation voltage (Ui)	V AC	250	
Rated impulse withstand voltage (Uimp)	kV	8 (OVC IV)	
Pollution degree		3	
Degree of protection		IP20B device only	
		IP40 device in modular enclosure	
Width in 9 mm modules		2	
Auxiliary contact (O/C) Ti24		24 V DC protected output, min. 2 mA, max. 100 mA	
Contact		1 O/C operating category AC 14	
Operating temperature	°C	-25°C to +60°C	
Storage temperature	°C	-40°C to +80°C	
Consumption		<1 W	
Standard		IEC/EN 60947-5-1	

(1) Mechanical and electrical connection.

iTL impulse relays (cont.)

Electrical auxiliaries for iTL impulse relays (cont.)



Operation of the iATL24

O/C 24 V DC output

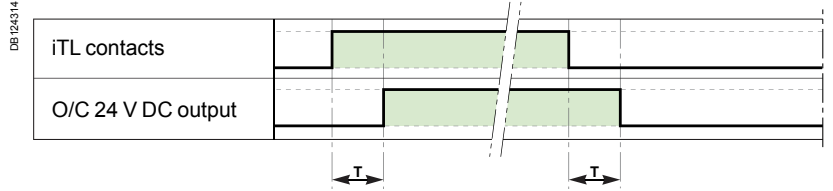

Parameter	Min	Max
T Time delay between iATL24 closing and indication	100 ms	200 ms

- Minimum duration of 230 V AC pulse (Y2): 200 ms.
- 30 iATL24 closing or opening actuations are authorized per minute: Minimum time delay between 2 actuations on the iATL24 via Y1, Y2, Y3 (closing or opening of the iTL coil): 440 ms.
- 10 closing or opening actuations spaced 440 milliseconds apart are authorized following no loading of the iATL24 during a period of 20 seconds.

Wiring with exclusive selector 230 V AC and 24 V DC controls

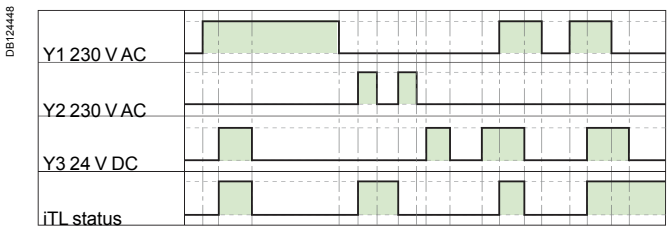
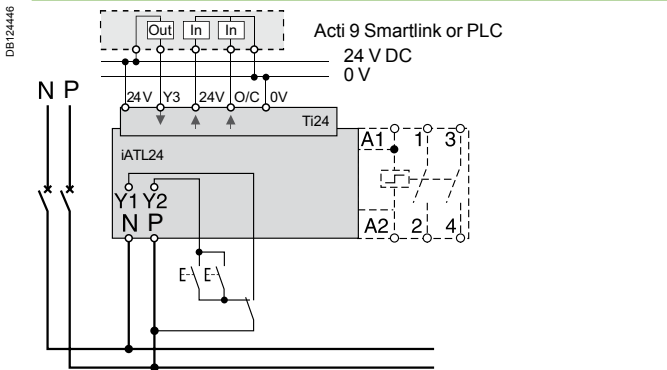

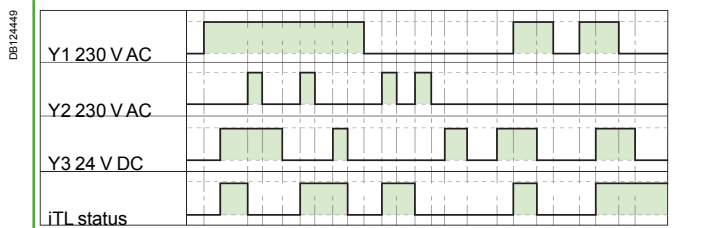
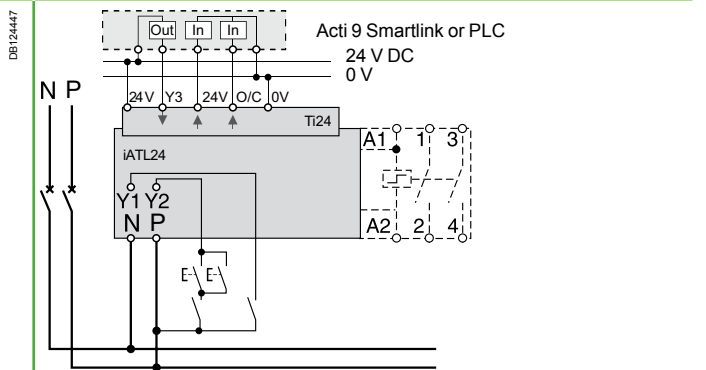

Wiring for non-exclusive 230 V AC and 24 V DC controls



Control
Remote control

iTL impulse relays (cont.)
Accessories for iTL impulse relays

		Security	
Accessories	Yellow clips	Spacer	
	 <p>PB106143-10</p>	 <p>PB104483</p>	
Function	<ul style="list-style-type: none"> Ensure the mechanical and/or electrical link between impulse relays and their auxiliaries (set of 10). 	<ul style="list-style-type: none"> Required to reduce temperature rise of modular devices installed side by side. Recommended to separate electronic devices (thermostat, programmable clock, etc.) from electromechanical devices (relays, contactors). 	
Catalogue numbers	A9C15415	A9A27062	
Technical specifications			
Width in 9 mm modules	-	1	

Dimensions (mm)

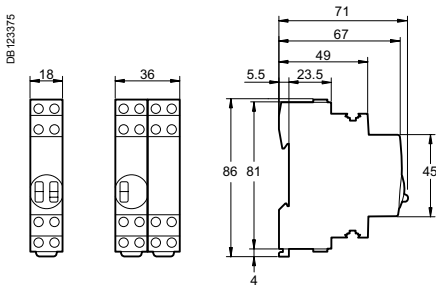

iTL 1P
iTLc
iTLm
iTLs
iTLi
iETL

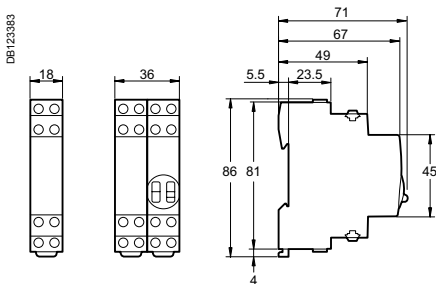

iATLc+s
iATLc+c
iATLz
iATL4

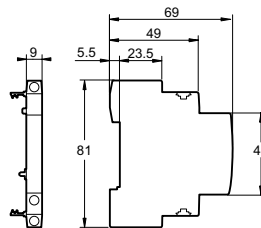

iATLc
iATLs
iATLm

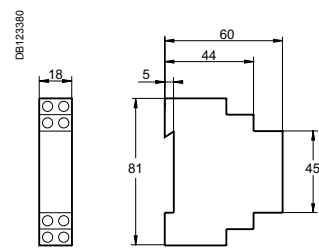

iATET

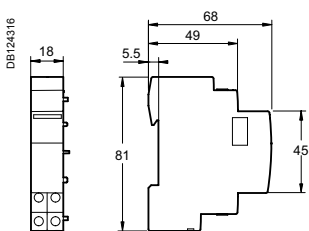

iATL24

Control Remote control iTL+ high-performance impulse relays

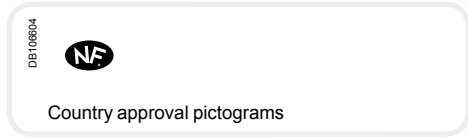

EN 60669-2-2

The iTL+ high-performance impulse relay allows remote control of single-phase circuits. It is designed for demanding applications.

The iTL+ high-performance impulse relay is used for push-button control of lighting circuits consisting of:

- incandescent lamps, low-voltage halogen lamps, etc. (resistive loads)
- fluorescent tubes, discharge lamps, etc. (inductive loads).

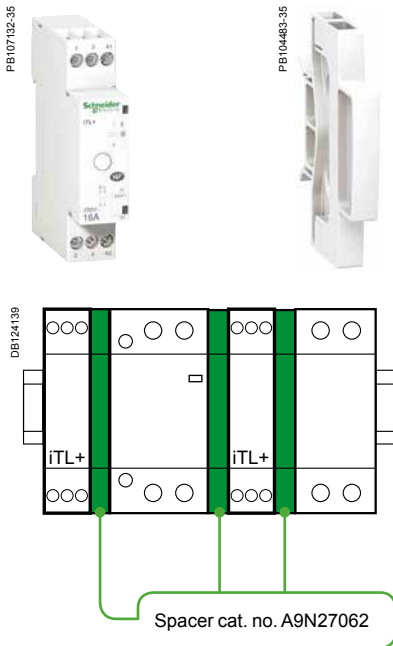

iTL+			
Type	Rating		Width in 9 mm modules
1P+N	16 A	A9C15032	2+1 ⁽¹⁾

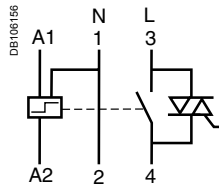

(1) Supplied with a 9 mm spacer (cat. no. A9N27062): to be used for mounting the iTL+ alongside a circuit breaker, contactor, impulse relay, etc., in order to maintain optimal operation.



It is compulsory:

- to connect the neutral
- to keep the same control circuit connection "A1: phase", "A2: neutral"
- to use the same phase for connection of the power and control functions.

Operation

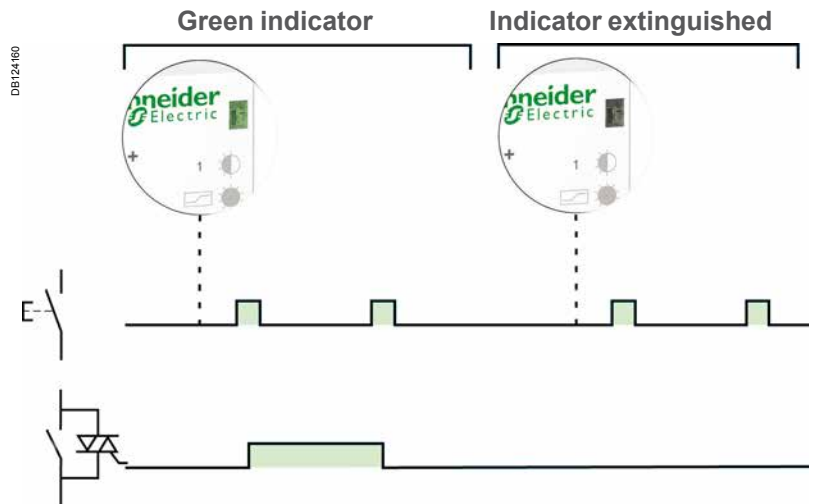

Connection

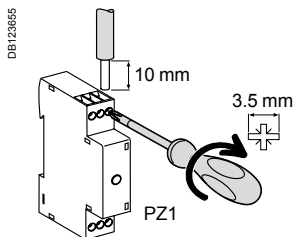

Type	Rating	Tightening torque	Copper cables	
			Rigid or flexible with ferrule	Rigid or flexible without ferrule
iTL+	16 A	1 N.m	 2 x 1.5 mm ²	 2 x 2.5 mm ² 1 x 4 mm ²

iTL+ high-performance impulse relays (cont.)

They combine the benefits of static switching and electromechanical technology: small size, little temperature rise.

■ Silent
■ Large number of switching operations

■ Green indicator on the front panel:
□ fixed green: ON/OFF control by push button
□ flashing green: forced starting
□ extinguished: forced stoppage

■ Orange indicator: output contact closed

■ Operating mode selection push button:
□ ON/OFF control by push button
□ forced starting
□ forced stoppage

■ Equivalent performances with all types of lamps

Following a mains failure, the iTL+ returns to 0 position (forced stoppage) irrespective of its initial state.

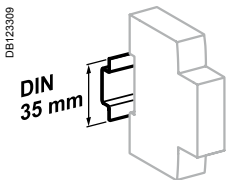

Clip on DIN rail 35 mm.

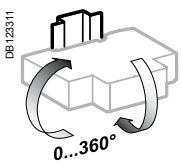

Indifferent position of installation.

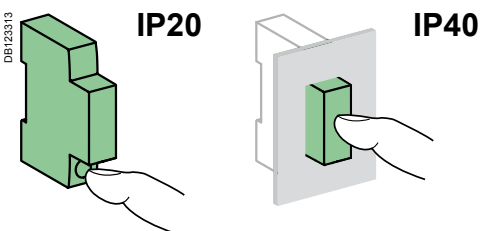

Technical data

Control circuit		
Coil voltage (Uc)		230 V AC
Frequency		50 Hz
Inrush power		11 VA
Holding power		1.1 VA
Control by luminous push button		Max. current 5 mA
Control order duration		50 ms to 1 s (recommended 200 ms)
Power circuit		
Voltage rating (Ue)		230 V AC
Frequency		50 Hz
Electrical load	Minimum	20 W
	Maximum	3600 W
Max. number of switching operations per minute		6
Other characteristics		
Degree of protection (IEC 60529)	Device only	IP20
	Device in modular enclosure	IP40 Insulation class II
Endurance (O-C)	Electrical	5.000.000 cycles (AC21 - AC22)
Noise level at activation		< 30 dBA
Operating temperature		-5°C to +55°C
Storage temperature		-40°C to +60°C
Tropicalization (IEC 60068-1)		Treatment 2 (relative humidity of 95 % at 55°C)

Weight (g)

High-performance impulse relays	
Type	iTL+
1P+N	70

Control Remote control iCT+ high-performance contactors

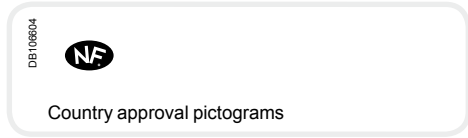

iCT+ high-performance contactors allow remote control of single-phase circuits. They are designed for demanding applications.

EN 60669-2-2

iCT+ high-performance contactors can be used for remote control of applications on AC networks:

- lighting, heating, ventilation, roller blinds, domestic hot water
- mechanical ventilation systems, etc.
- load shedding on non-priority circuits.



iCT+				
Type	Rating	Contact		Width in 9-mm modules
Standard 1P+N				
	20 A	1 NO	A9C15030	2+1 ⁽¹⁾
1P+N with manual control				
	20 A	1 NO	A9C15031	2+1 ⁽¹⁾

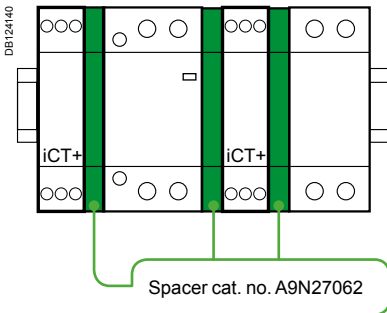

(1) Supplied with a 9 mm spacer (cat. no. A9N27062): to be used for mounting the iCT+ alongside a circuit breaker, contactor, impulse relay, etc., in order to maintain optimal operation.

It is compulsory:

- to connect the neutral
- to keep the same control circuit connection "A1: phase", "A2: neutral"
- to use the same phase for connection of the power and control functions.

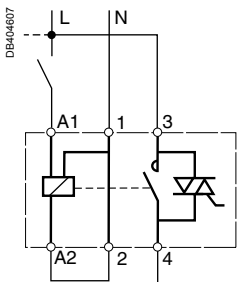

Operation (manual-control contactor)

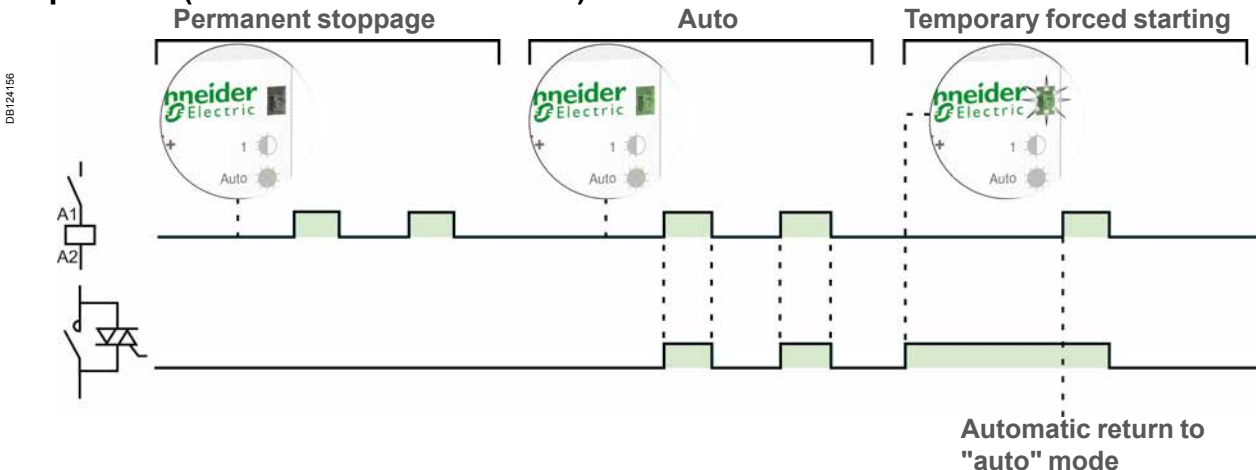

Control Remote control

iCT+ high-performance contactors (cont.)

They combine the benefits of static switching and electromechanical technology: small size, little temperature rise.

- Silent
- Large number of switching operations
- Green indicator on the front panel:
 - fixed green: auto operation
 - flashing green: temporary forced starting
 - extinguished: permanent stoppage
- Operating mode selection push button:
 - auto operation
 - temporary forced starting*
 - permanent stoppage
- Orange indicator: output contact closed
- Equivalent performances with all types of lamps
- No derating

Following a mains failure, the iCT+ returns to "auto" operating mode irrespective of its initial state.

Connection

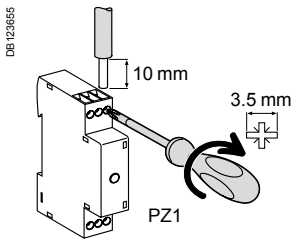

Type	Tightening torque	Copper cables	
		Rigid or flexible with ferrule	Rigid or flexible without ferrule
iCT+	1 N.m	2 x 1.5 mm ²	2 x 2.5 mm ² 1 x 4 mm ²

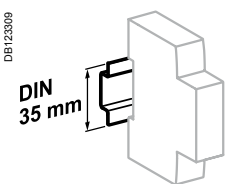

Clip on DIN rail 35 mm.

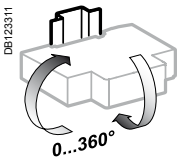

Indifferent position of installation.

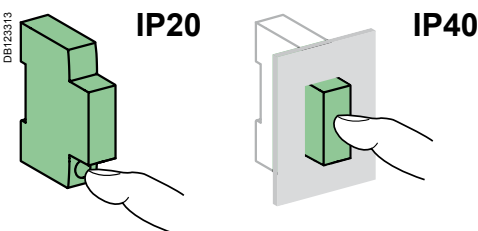

Technical data

Control circuit		
Coil voltage (Uc)		230 V AC (± 10 %)
Frequency		50 Hz
Inrush power		11 VA
Holding power		1.1 VA
Power circuit		
Voltage rating (Ue)		230 V AC (± 10 %)
Frequency		50 Hz
Electrical load	Minimum	20 W
	Maximum	3600 W
Max. number of switching operations per minute		6
Other characteristics		
Endurance (O-C)	Electrical	5.000.000 cycles
Pollution degree		3
Degree of protection (IEC 60529)	Device only	IP20
	Device in modular enclosure	IP40 Insulation class II
Operating temperature		-5°C to +55°C
Storage temperature		-40°C to +60°C
Tropicalization (IEC 60068-1)		2 (relative humidity of 95 % at 55°C)

Weight (g)





High-performance contactors	
Type	iCT+
Standard 1P+N	70
1P+N with manual control	70

Monitor Indication iLL indicator lights



IEC 60947-5-1

■ iLL indicator lights light up to indicate that a voltage is present.

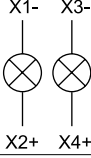
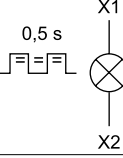
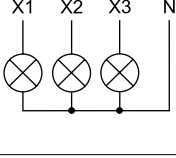
Catalogue numbers

iLL indicator lights										
Type	Single					Double		Flashing light	Three-phase voltage presence indicator light	
										
Diagram										
Colour	Red	Green	White	Blue	Yellow	Green/red	White/white	Red	Red/red/red	
Cat. no.										
12...48 V AC/DC	A9E18330	A9E18331	A9E18332	A9E18333	A9E18334	A9E18335	-	-	-	
110...230 V AC 110...130 V DC	A9E18320	A9E18321	A9E18322	A9E18323	A9E18324	A9E18325	A9E18328	-	-	
110...230 V AC	-	-	-	-	-	-	-	A9E18326	-	
230...400 V AC (3 phases)	-	-	-	-	-	-	-	-	A9E18327	
Width in 9 mm modules	2					2		2	2	

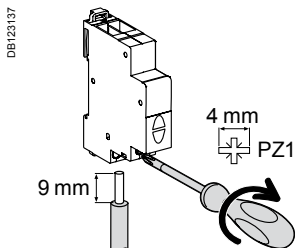
Connection

	Tightening torque	Copper cables	
	1 N.m	Rigid	Flexible or with ferrule
		 0.5 mm ² min. 2 x 2.5 mm ² max.	 0.5 mm ² min. 2 x 2.5 mm ² max.

- Phase-separated wall that can be divided to allow the teeth of all types of comb busbar to pass through.
- Staggered terminals to simplify connection.

Dimensions (mm)

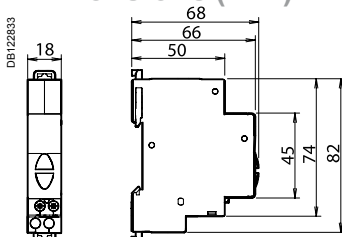

Technical data

Main characteristics	
Pollution degree	3
Power circuit	
Operating frequency	50...60 Hz
Flashing frequency	2 Hz
Additional characteristics	
Operating temperature	-35°C... +70°C
Storage temperature	-40°C... +80°C
Tropicalization	Treatment 2 (relative humidity 95 % at 55°C)
LED indicator light	Consumption per indicator light: 0.3 W Service life: 100,000 hours of constant lighting efficiency Maintenance-free indicator light (non-interchangeable LEDs)

Measurement and indication



iSO bells and iRO buzzers



iSO and iRO

Audible indication in housing and the tertiary sector.

Catalogue numbers

Bell and buzzer			
Type	Voltage (Ue)		Width in 9 mm modules
iSO bell 	230 V AC	A9A15320	2
	8...12 V AC	A9A15321	2
iRO buzzer 	230 V AC	A9A15322	2
	8...12 V AC	A9A15323	2
Operating frequency		50...60 Hz	

Connection

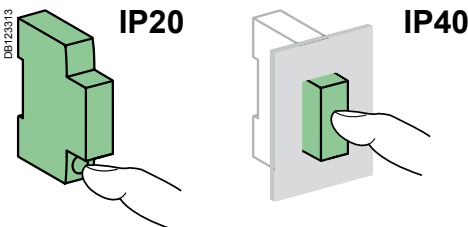
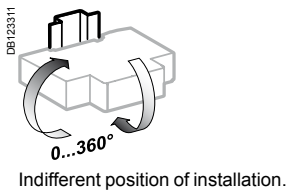
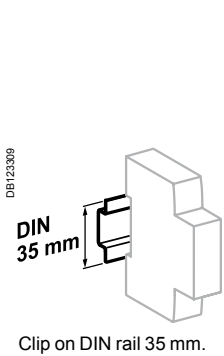

Tightening torque	Copper cables	
	Rigid	Flexible or with ferrule
1.3 N.m	< 4 mm ²	< 4 mm ²

Technical data

Main characteristics		iSO	iRO
Consumption	8...12 V AC	3.6 VA	
	220...240 V AC	5 VA	
Additional characteristics			
Degree of protection (IEC 60529)	Device only	IP40	
	Device in modular enclosure	IP20	
Operating temperature		-10°C to +40°C	
Storage temperature		-25°C to +60°C	
Sound level (at a distance of 60 cm)		80 dBA	70 dBA

Weight (g)

Bell and buzzer	
Type	Weight (g)
iSO	77
iRO	64

Dimensions (mm)

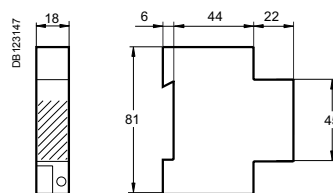

iSO bell and iRO buzzer



Country approval pictogram

PB107156-35



PB107156-35



Bell transformers: EN/IEC 61558-2-8.

Safety transformers: EN/IEC 61558-2-6.

Bell transformers and safety transformers allow for a very low voltage (ELV 8 V, 12 V or 24 V) to be obtained from a low voltage network (LV 230 V).

All Schneider Electric transformers are:

- Safe: primary and secondary circuits are perfectly insulated by each other
- Resistant to short-circuit currents thanks to the built-in device
- Class II with terminal shield (optional).

Catalogue numbers

Bell transformer				
Type	Power	Secondary voltage		Width in 9 mm modules
E56759 	4 VA	8 V AC	A9A15214	4
E56760 	4 VA	8-12 V AC	A9A15213	4
	8 VA	8-12 V AC	A9A15216	4
	16 VA	8-12 V AC	A9A15212	4
E56761 	25 VA	12-24 V AC	A9A15215	6

Safety transformer				
Type	Power	Secondary voltage		Width in 9 mm modules
DB124153 	16 VA	12-24 V AC	A9A15218	10
	25 VA	12-24 V AC	A9A15219	10
DB124154 	40 VA	12-24 V AC	A9A15220	10
	63 VA	12-24 V AC	A9A15222	10
DB124155 				
Operating frequency	50/60 Hz			

Terminal shield			
Type			Width in 9 mm modules
	15228		4
	15229		6

Connection

Tightening torque	Copper cables	
	Rigid	Flexible or with ferrule
0.5 N.m	 DBI122846 < 2.5 mm ²	 DBI122846 < 2.5 mm ²

Technical data

Main characteristics		
Primary voltage		230 V AC ±10 %
Secondary voltage on load	For bell transformers	8-12-24 V AC ±15 %
	For safety transformers	12-24 V AC ±5 %
Transformer catalogue numbers	Rated secondary voltage	Off load voltage
A9A15214	8 V	12 V
A9A15213	8 V	12 V
	12 V	16 V
A9A15216	8 V	13 V
	12 V	18 V
A9A15212	8 V	13 V
	12 V	18 V
A9A15215	12 V	16 V
	24 V	32 V
A9A15218	12 V	14 V
	24 V	28 V
A9A15219	12 V	14 V
	24 V	28 V
A9A15220	12 V	14 V
	24 V	28 V
A9A15222	12 V	14 V
	24 V	28 V
Additional characteristics		
Degree of protection (IEC 60529)	Device only	IP20 with terminal shield
Operating temperature		-20°C to +55°C
Storage temperature		-25°C to +80°C

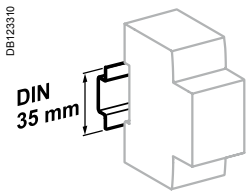

Clip on DIN rail 35 mm.

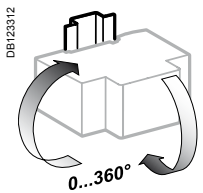

Bell transformer: indifferent position of installation.
Safety transformer: vertical position.

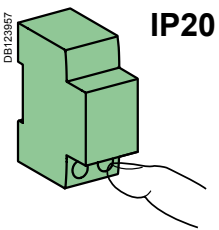

Note: Transformers have an off load operating voltage that is higher than the rated voltage. For loads that are sensitive to overloads (electro-magnetic circuits), the transformer must be made to operate at In. After operation of the protection device upon an overload, cut-off the power supply and let the transformer cool down before restart.

Weight (g)

iTR		
Type	Cat. no.	Weight
Bell	A9A15212	384
	A9A15213	240
	A9A15214	237
	A9A15215	633
	A9A15216	275
Safety	A9A15218	1082
	A9A15219	1125
	A9A15220	1190
	A9A15222	1309

Dimensions (mm)

36	54	90	5	39	16
89					45

A9A15212	A9A15215	A9A15218
A9A15213		A9A15219
A9A15214		A9A15220
A9A15216		A9A15222

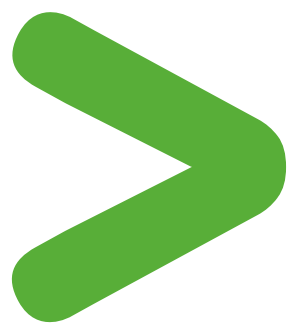

Monitoring Control / Remote control Relays

Time delay relays are used in service sector and industrial buildings for small automatic control systems: ventilation, heating, animation, roller blind servo controls, escalators, pumps, lighting, signalling, monitoring, etc.

> Time delay relays



iRTA
■ Delays energizing of a load



iRTB
■ Delays de-energizing of a load upon closing of an auxiliary contact (push button)



iRTC
■ Delays de-energizing of a load upon opening of an auxiliary contact (push button)

^ Time delay

iRBN and iRTBT relays can interface automatic control system inputs/ outputs with low-voltage devices.

> Interface relays



iRBN
Low level relay
■ Actuation of low-amperage electronic circuits upon receiving an LV electrical order



iRTBT
Extra low voltage relay
■ Actuation of LV circuits based on an extra low voltage order

^ Control

Control relays monitor electrical parameters and indicate when they are exceeded

> Control relays



iRCP
Phase control
■ Monitors the order and asymmetry of phases and the presence of voltage on the 3 phases of a three-phase circuit (power supply of a motor, etc.)



iRCI
Current control
■ Monitors the current flowing in a circuit and indicates any crossing of the set threshold

^ Monitoring

Monitoring Control / Remote control Relays (cont.)



iRTH
■ Applies a time delay to de-energizing of a load



iRTL
■ Applies a time delay to energizing and de-energizing of a load during different times, repeatedly (flasher)



iRTMF
■ Allows one of the four types of time delay to be selected: A, B, C or H

iRLI and iERL relays are used to relay ON or OFF information to the auxiliary circuits and actuate low-power loads

> Changeover relays



iRLI Changeover
■ Relays ON or OFF information to the auxiliary circuits
■ Actuates low-power loads



iERL extension

^ Relaying and control





iRCU Voltage control
■ Monitors the potential difference of a circuit and indicates any crossing of the set threshold



iRCC Compressor control
■ Monitors the compressor power supply and prevents its immediate restarting upon detection of a power cut or voltage dip

Time delay relays

iRTA, iRTB, iRTC, iRTH, iRTL and iRTMF

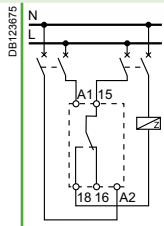
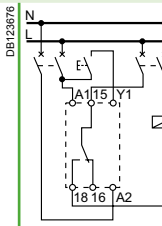
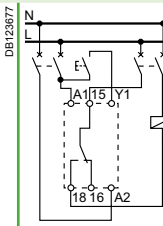
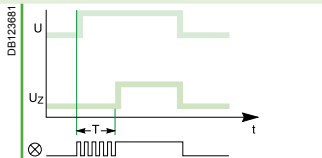
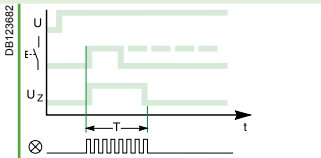
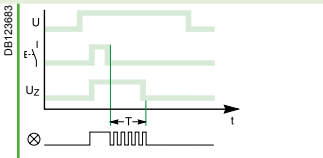
		Time delay relays		
		iRTA	iRTB	iRTC
Type				
Function		■ Delays energizing of a load	■ Delays de-energizing of a load upon closing of an auxiliary contact (push button)	■ Delays de-energizing of a load upon opening of an auxiliary contact (push button)
Wiring diagrams				
Use		 <ul style="list-style-type: none"> ■ The single time delay cycle starts at switching on of the iRTA relay power supply ■ The load is energized at the end of time delay T 	 <ul style="list-style-type: none"> ■ The single time delay cycle starts at closing of an auxiliary contact (push button) ■ The load is de-energized at the end of time delay T 	 <ul style="list-style-type: none"> ■ The single time delay cycle starts only upon release of an auxiliary contact (push button) ■ The load is de-energized at the end of time delay T
Catalogue numbers		A9E16065	A9E16066	A9E16067
Technical specification				
Control and power supply voltage (Uc)	V AC	24...240, ±10 %	24...240, ±10 %	24...240, ±10 %
	V DC	24, ±10 %	24, ±10 %	24, ±10 %
Operating frequency	Hz	50/60	50/60	50/60
Time delay range		0.1 s to 100 h	0.1 s to 100 h	0.1 s to 100 h
Precision		±10 % of full scale	±10 % of full scale	±10 % of full scale
Minimum duration of control impulse		100 ms	100 ms	100 ms
Insensitive to brownouts		≤ 20 ms	≤ 20 ms	≤ 20 ms
Max. resetting time per voltage interruption		100 ms	100 ms	100 ms
Accuracy of repetition		±0.5 % at constant parameters	±0.5 % at constant parameters	±0.5 % at constant parameters
Changeover contact (cadmium free)	Mini	Rating 10 mA/5 V DC	Rating 10 mA/5 V DC	Rating 10 mA/5 V DC
	Maxi	Rating 8 A/250 V AC/DC	Rating 8 A/250 V AC/DC	Rating 8 A/250 V AC/DC
Endurance	Mechanical	> 5 x 10 ⁶ switching operations	> 5 x 10 ⁶ switching operations	> 5 x 10 ⁶ switching operations
	Electrical	> 10 ⁵ switching operations (utilization category AC1)	> 10 ⁵ switching operations (utilization category AC1)	> 10 ⁵ switching operations (utilization category AC1)
Display of contact status by green indicator lamp		Flashing during time delay	Flashing during time delay	Flashing during time delay
Degree of protection	Device only	IP20	IP20	IP20
Connection by tunnel terminals	Without ferrule	2 x 2.5 mm ² single-strand	2 x 2.5 mm ² single-strand	2 x 2.5 mm ² single-strand
	With ferrule	2 x 1.5 mm ² multi-strand	2 x 1.5 mm ² multi-strand	2 x 1.5 mm ² multi-strand
Width in 9-mm modules		2	2	2
Operating temperature	°C	-5 ... +55	-5 ... +55	-5 ... +55
Storage temperature	°C	-40 ... +70	-40 ... +70	-40 ... +70



Monitoring Control / Remote control

Time delay relays



iRTA, iRTB, iRTC, iRTH, iRTL and iRTMF (cont.)

	iRTH	iRTL	iRTMF
	<ul style="list-style-type: none"> Applies a time delay to de-energizing of a load 	<ul style="list-style-type: none"> Applies a time delay to energizing and de-energizing of a load during different times, repeatedly (flasher) 	<ul style="list-style-type: none"> Allows one of the four types of time delay to be selected: A, B, C or H
	<ul style="list-style-type: none"> The single time delay cycle starts at switching on of the iRTH relay power supply The load is de-energized at the end of time delay T 	<ul style="list-style-type: none"> The time delay cycle starts at energizing The load is energized during an adjustable time T1 and then de-energized during an adjustable time T2. This cycle is reproduced until de-energizing of the iRTL relay power supply 	<ul style="list-style-type: none"> Depending on the choice, the iRTMF generates time delay cycles for the iRTA, iRTB, iRTC or iRTH relays
	A9E16068	A9E16069	A9E16070
	24...240, ±10 %	24...240, ±10 %	12...240, ±10 %
	24, ±10 %	24, ±10 %	12...240, ±10 %
	50/60	50/60	50/60
	0.1 s to 100 h	0.1 s to 100 h	0.1 s to 100 h
	±10 % of full scale	±10 % of full scale	±10 % of full scale
	100 ms	100 ms	100 ms
	≤ 20 ms	≤ 20 ms	≤ 20 ms
	100 ms	100 ms	100 ms
	±0.5 % at constant parameters	±0.5 % at constant parameters	±0.5 % at constant parameters
	Rating 10 mA/5 V DC	Rating 10 mA/5 V DC	Rating 10 mA/5 V DC
	Rating 8 A/250 V AC/DC	Rating 8 A/250 V AC/DC	Rating 8 A/250 V AC/DC
	> 5 x 10 ⁶ switching operations	> 5 x 10 ⁶ switching operations	> 5 x 10 ⁶ switching operations
	> 10 ⁵ switching operations (utilization category AC1)	> 10 ⁵ switching operations (utilization category AC1)	> 10 ⁵ switching operations (utilization category AC1)
	Flashing during time delay	Flashing during time delay	Flashing during time delay
	IP20	IP20	IP20
	2 x 2.5 mm ² single-strand	2 x 2.5 mm ² single-strand	2 x 2.5 mm ² single-strand
	2 x 1.5 mm ² multi-strand	2 x 1.5 mm ² multi-strand	2 x 1.5 mm ² multi-strand
	2	2	2
	-5 ... +55	-5 ... +55	-5 ... +55
	-40 ... +70	-40 ... +70	-40 ... +70

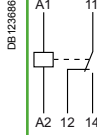
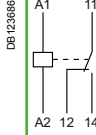



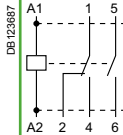
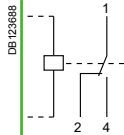

Monitoring Control / Remote control Interface relays iRBN, iRTBT

Interface relays			
	iRBN	iRTBT	
Type	Low level	Extra low voltage	
			
Standard	IEC/EN 61810-1	IEC/EN 61810-1	
Function	<ul style="list-style-type: none"> ■ Actuation of low-amperage electronic circuits upon receiving an LV electrical order 	<ul style="list-style-type: none"> ■ Actuation of LV circuits based on an extra low voltage order 	
Wiring diagrams			
Use	<ul style="list-style-type: none"> ■ Inputs of programmable logic controllers, of measuring or supervision circuits, etc. 	<ul style="list-style-type: none"> ■ ELV orders can be issued by a programmable logic controller (24 V DC static outputs), a central fire detection unit, a regulation system, etc. 	
Catalogue numbers	A9A15393	A9A15416	
Technical specification			
Input control voltage (Uc)	V AC	230, ±10 %	12...24, -15 to +10 %
	V DC	-	12...24, ±20 %
Output contact rating	Mini	5 mA/5 V DC (DC12) 5 mA/5 V AC	10 mA/10 V DC (DC12) 10 mA/10 V AC
	Maxi	1 A/24 V DC (DC12) 5 A/250 V AC	1 A/24 V DC (DC12) 5 A/250 V AC
Operating frequency	Hz	50/60	0...60
Strengthened insulation between ELV/LV circuits		4 kV	4 kV
Consumption	At inrush	5 VA	0.22 W
	At holding	2.5 VA	0.11 W
Endurance	Electrical	100,000 switching operations	100,000 switching operations
Display of voltage presence on the control circuit		By green indicator lamp	By green indicator lamp
Degree of protection	Device only	IP20	IP20
Connection by tunnel terminals		0.5 x 6 mm ²	0.5 x 6 mm ²
Width in 9-mm modules		2	2
Operating temperature	°C	-5 ... +55	-5 ... +55
Storage temperature	°C	-40 ... +70	-40 ... +70

iRLI changeover and iERL extension relays

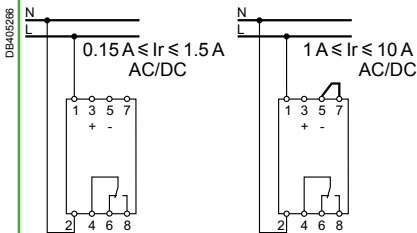
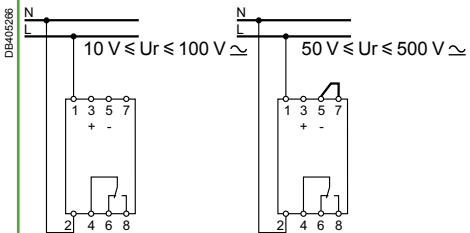

Changeover and extension relays									
	iRLI				iERL				
Type	Changeover relay				Extension for RLI				
									
Standard	IEC/EN 61810-1 and NF C 45-250				IEC/EN 61810-1 and NF C 45-250				
Function	<ul style="list-style-type: none"> Relaying of ON or OFF information to the auxiliary circuits and actuation of low-power loads 				<ul style="list-style-type: none"> Extension allowing additional contacts to be added to the iRLI changeover relays 				
Wiring diagrams									
Use	<ul style="list-style-type: none"> The iRLI relay contains 1 changeover contact (O-C) and 1 normally open contact (N/O) 				<ul style="list-style-type: none"> The iERL extension (max. 3 iERLs for 1 iRLI) contains 1 changeover contact (O-C) and 1 normally open contact (N/O) Can be mounted without any tool and without additional cabling using a yellow clip which performs mechanical assembly and electrical connection between the coils 				
Catalogue numbers	A9E15535	A9E15536	A9E15537	A9E15538	A9E15539	A9E15540	A9E15541	A9E15542	
Technical specification									
Control voltage (Uc)	V AC	230...240	48	24	12	230...240	48	24	12
Voltage rating (Ue)	V AC	230							
Insulation voltage (Ui)	V AC	250							
Rating (In)	A	10, cos φ = 1				10, cos φ = 1			
Operating frequency	Hz	50/60				50/60			
Inrush and holding power		4 VA				iRLI + iERL : 8 VA			
Endurance	Electrical	100,000 cycles AC21 (cos φ = 1)				100,000 cycles AC21 (cos φ = 1)			
Direct front face control	Power	By push button				By push button			
	Coil	By selector switch (disconnection)				By selector switch (disconnection)			
Position indicator		Mechanical indicator				Mechanical indicator			
Marking		Clip-on markers on the front panel				Clip-on markers on the front panel			
Degree of protection	Device only	IP20				IP20			
Connection by tunnel terminals		0.5 x 6 mm ²				0.5 x 6 mm ²			
Width in 9-mm modules		2				2			
Operating temperature	°C	-5 ... +55				-5 ... +55			
Storage temperature	°C	-40 ... +70				-40 ... +70			

iRCP phase control, iRCI current control, iRCU voltage control and iRCC compressor control relays

Control relays		
Type	iRCI Current control	iRCU Voltage control
		
Function	<ul style="list-style-type: none"> Monitors the current (I_r) flowing in an AC or DC circuit and indicates any crossing of the set threshold 	<ul style="list-style-type: none"> Monitors the voltage variation (U_r) of an AC or DC circuit and indicates any crossing of the set threshold
Wiring diagrams		
Catalogue numbers	A9E21181	A9E21182
Common technical specification		
Supply voltage (U_c)	V AC	230, -15 % à +10 %
Frequency	Hz	50/60
Parameter setting		<ul style="list-style-type: none"> On the front panel, by direct scale, using a screwdriver
Precision of display		±10 % of full scale
Output by changeover contact		8 A under 250 V AC ($\cos \varphi = 1$)
Indications by LED	Green	Voltage presence
	Red	Fault
Consumption	VA	3
Dissipated power	W	2
Degree of protection	Device only	IP20
Connection by tunnel terminals	Rigid cable	1.5 x 6 mm ²
Width in 9-mm modules		4
Operating temperature	°C	-5 ... +55
Storage temperature	°C	-40 ... +80
Particular technical specification		
	Threshold adjustable from 10 % to 100 % of I_r	Threshold adjustable from 10 % to 100 % of U_r
	Hysteresis adjustable from 5 % to 50 % of I_r	Hysteresis adjustable from 5 % to 50 % of U_r
	Monitoring of overcurrent and undercurrent (selection by selector switch)	
	Fail-safe contact	
	De-energized	
	Energized with fault	
	Energized without fault	
	Time delay on crossing threshold: 0.1 s to 10 s	
	Possibility of memorizing fault with resetting	
	Compatible with current transformers (CTs) of ratio X/5	<ul style="list-style-type: none"> Automatic recognition of AC voltage or DC voltage. 2 measuring ranges selected by cabling: <ul style="list-style-type: none"> 10 V to 50 V 50 V to 500 V
	<ul style="list-style-type: none"> Automatic recognition of alternating or direct current. 2 measuring ranges selected by cabling: <ul style="list-style-type: none"> 0.15 A to 1.5 A 1 A to 10 A 	

Monitoring Control / Remote control

iRCP phase control, iRCI current control, iRCU voltage control and iRCC compressor control relays (cont.)

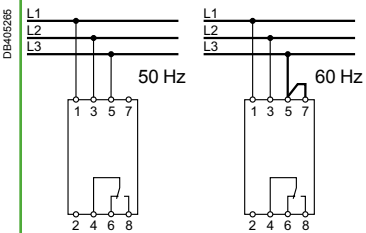
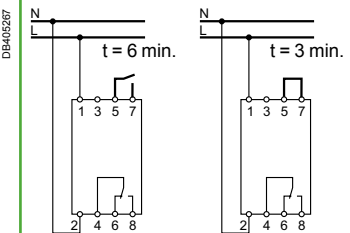
iRCP		iRCC	
Phase control		Compressor control	
 <p>PE107124-35</p>	 <p>PE107127-35</p>		
<p>■ Monitors phases and the presence of voltage on the 3 phases of a three-phase circuit (power supply of a motor, etc.). It indicates any phase loss or inversion</p>		<p>■ Monitors the compressor's power supply and prevents its immediate restarting upon detection of a power cut or voltage dip</p>	
 <p>DB405266</p>		 <p>DB405267</p>	
A9E21180		A9E21183	
400, ±15 %		230, -15 % à +10 %	
50/60			
■ On the front panel, by direct scale, using a screwdriver			
±10 % of full scale			
8 A under 250 V AC (cos φ = 1)			
Voltage presence			
Fault			
3			
3 (total on the 3 phases)		2	
IP20			
1.5 x 6 mm ²			
4			
-5 ... +55			
-40 ... +80			
Setting of phase asymmetry threshold: 5 % to 2 5% of 400 V		Threshold setting: ±5 % to ±15 % of 230 V	
Hysteresis: fixed, 5 % of asymmetry threshold			
Monitoring of direction of phase rotation			
Monitoring of presence of the 3 phases			
Fail-safe contact		Fail-safe contact	
De-energized		De-energized	
Energized with fault		Energized with fault	
Energized without fault		Energized without fault	
Time delay on tripping: 0.3 s		Time delay on overshoot: 3 or 6 minutes (selection by cabling)	

Technical data

Weight (g)

Relays	
Type	Weight (g)
iRTA, iRTB, iRTC, iRTH, iRBN	65
iRTL	66
iRTMF	68
iRTBT	63
iRLI, iERL	112
iRCP, iRCC	210
iRCI, iRCU	215

Dimensions (mm)

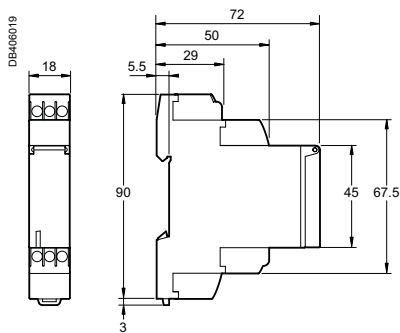

iRTA, iRTB, iRTC, iRTH, iRTL, iRTMF

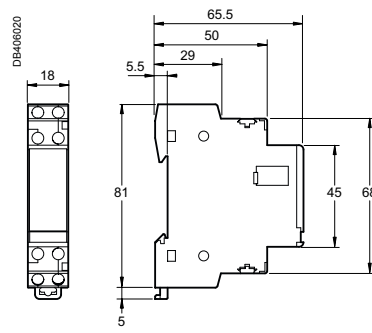

iRBN, iRTBT

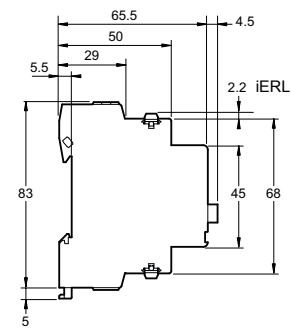

iRLI, iERL

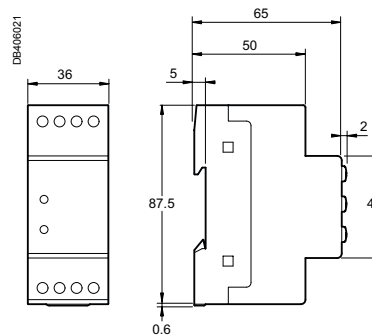

iRCP, iRCI, iRCU, iRCC

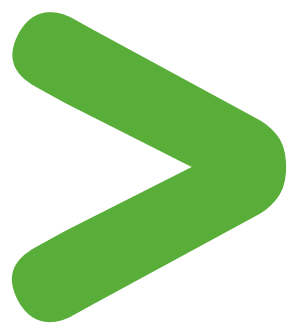

Life Is On | **Schneider**
Electric

Schneider Electric Danmark A/S

Lautrupvang 1
2750 Ballerup
Telefon: 88 30 20 00

www.se.com/dk

09 - 2019

© 2019 Schneider Electric. Alle rettigheder forbeholdes. Schneider Electric er et varemærke og ejes af Schneider Electric SE, dets datterselskaber og associerede selskaber.