

DISTRIBUTION PANEL OPTIONS			
OPTION REFERENCE	BREAKER FRAME RATING	MAX. QTY 3P	SHORT CIRCUIT CURRENT RATING
T1	100A	16	22kAIC
T3	225A	12	25kAIC
T5	400A	SEE NOTE-11	25kAIC

LEGEND:
 - - - - - AC CABLE - PROVIDED BY OTHERS

- NOTES:**
- INSTALLATION SHALL COMPLY WITH ALL APPLICABLE LOCAL AND NATIONAL CODES.
 - PLEASE REFER TO PRODUCT MANUALS FOR ADDITIONAL DETAILS.
 - DRAWING DEPICTS POWER SYSTEM CONNECTIONS AND IS NOT REPRESENTATIVE OF PHYSICAL LAYOUT, PLEASE REFER TO MECHANICAL DRAWINGS FOR PHYSICAL LAYOUT.
 - MAXIMUM RATED SHORT CIRCUIT CURRENT IS 50kA.
 - AC MAIN UTILITY SOURCE SHALL BE 415VAC, 3φ, SOLIDLY GROUNDED WYE, 3 WIRE+GROUND (CONTACT Schneider Electric IF OTHER). SEE SHEET 3 FOR SITE PLANNING SUBMITTAL DATA.
 - AC CABLING SHALL BE 600V RATED, 3 WIRE+GROUND.
 - AC BYPASS UTILITY SOURCE SHALL BE 415VAC, 3φ, SOLIDLY GROUNDED WYE, 4 WIRE+GROUND (CONTACT Schneider Electric IF OTHER). SEE SHEET 3 FOR SITE PLANNING SUBMITTAL DATA.
 - AC CABLING SHALL BE 600V RATED, 4 WIRE+GROUND.
 - SINGLE MAINS IS FACTORY DEFAULT CONFIGURATION. THE I/O FRAME TO MBwD FRAME BUS LINKS SHALL BE REMOVED FOR DUAL MAINS INSTALLATION. FOR SINGLE MAINS INSTALLATION CONTACT Schneider Electric FOR RELATED SUBMITTAL DRAWINGS.
 - THE NEUTRAL TO GROUND SYSTEM BONDING JUMPER PROVIDED BY Schneider Electric SHALL NOT BE INSTALLED FOR 4 WIRE OUTPUT CONFIGURATION. SEE INSTALLATION MANUAL FOR DETAILS.
 - MAXIMUM QUANTITY OF DISTRIBUTION BREAKERS (T5 OPTION ONLY)
 - 4 - IF THE NEUTRAL BAR KIT IS INSTALLED
 - 8 - IF THE NEUTRAL BAR KIT IS NOT INSTALLED.
 - THIS DRAWING SHOWS MINIMUM NUMBER OF XR BATTERY FRAMES. MAXIMUM (8) XR BATTERY FRAMES CAN BE BAYED TO UPS. BAYING KIT IS SUPPLIED WITH THIS SOLUTION. XR BATTERY FRAME HAS MOTORIZED BREAKER.
 - CABLE LUGS ARE NOT PROVIDED.

DEVICE RATING					
DEVICE	RATING	TYPE	MAKE	MODEL	ACCESSORIES
Q1	1000A, 600V	3P MCSW	Schneider Electric	ON-1003	1Aux.sw. K7AS
Q2	800AT/800AF, 600V	4P MCCB	ABB	S6N800BW-4	1Aux.sw. 24Vdc shunt trip
Q3	800A, 600V	4P MCSW	ABB	S6H800DW-4	1Aux.sw. K7AS
Q5	800A, 600V	3P MCSW	ABB	S6H800DW	1Aux.sw. K7AS
INVERTER FUSES F1-F3 / F4-F6	1250A, 700V	HIGH SPEED FUSE	BUSSMANN	170M6466	--
SSW FUSES F1-F3	1100A, 700V	HIGH SPEED FUSE	BUSSMANN	170M5167	--
DC BREAKER	400A, 600V DC	4P MCCB	ABB	1SDA06033R1	1Aux.contact, 24VDC, Shunt trip, Actuator

THIS DRAWING AND SPECIFICATIONS HEREIN ARE THE PROPERTY OF SCHNEIDER ELECTRIC AND SHALL NOT BE COPIED, REPRODUCED OR USED IN WHOLE OR IN PART, AS THE BASIS FOR THE MANUFACTURE OR SALE OF ITEMS WITHOUT WRITTEN PERMISSION FROM SCHNEIDER ELECTRIC. THIS DRAWING IS BASED UPON LATEST AVAILABLE INFORMATION AND IS SUBJECT TO CHANGE WITHOUT NOTICE.



TITLE:	SYMMETRA PX INPUT: 415V 3φ WYE, DUAL MAINS OUTPUT: 415V 500kVA/kw BOTTOM FEED WITH LINE-UP BATTERIES SYSTEM ONE LINE DIAGRAM	DWG NO:	SY500K500BH2C1-4W-SD	REV.	3
PROJECT:	SUBMITTAL DRAWINGS	SHEET	1 OF 3	APPROVED:	B SHERIDAN
DATE:	29-JUL-15	DATE:	29-JUL-15	DATE:	29-JUL-15
DRAWN:	V BUSH/S CUNHA/BALA	DATE:	29-JUL-15	PROJECT:	PROJ ANGLE N.A
ENGINEER:	C FLY/A WARNER	DATE:	29-JUL-15	PROJECT:	PROJ ANGLE N.A

4 WIRE OUTPUT CONFIGURATION, DUAL MAINS

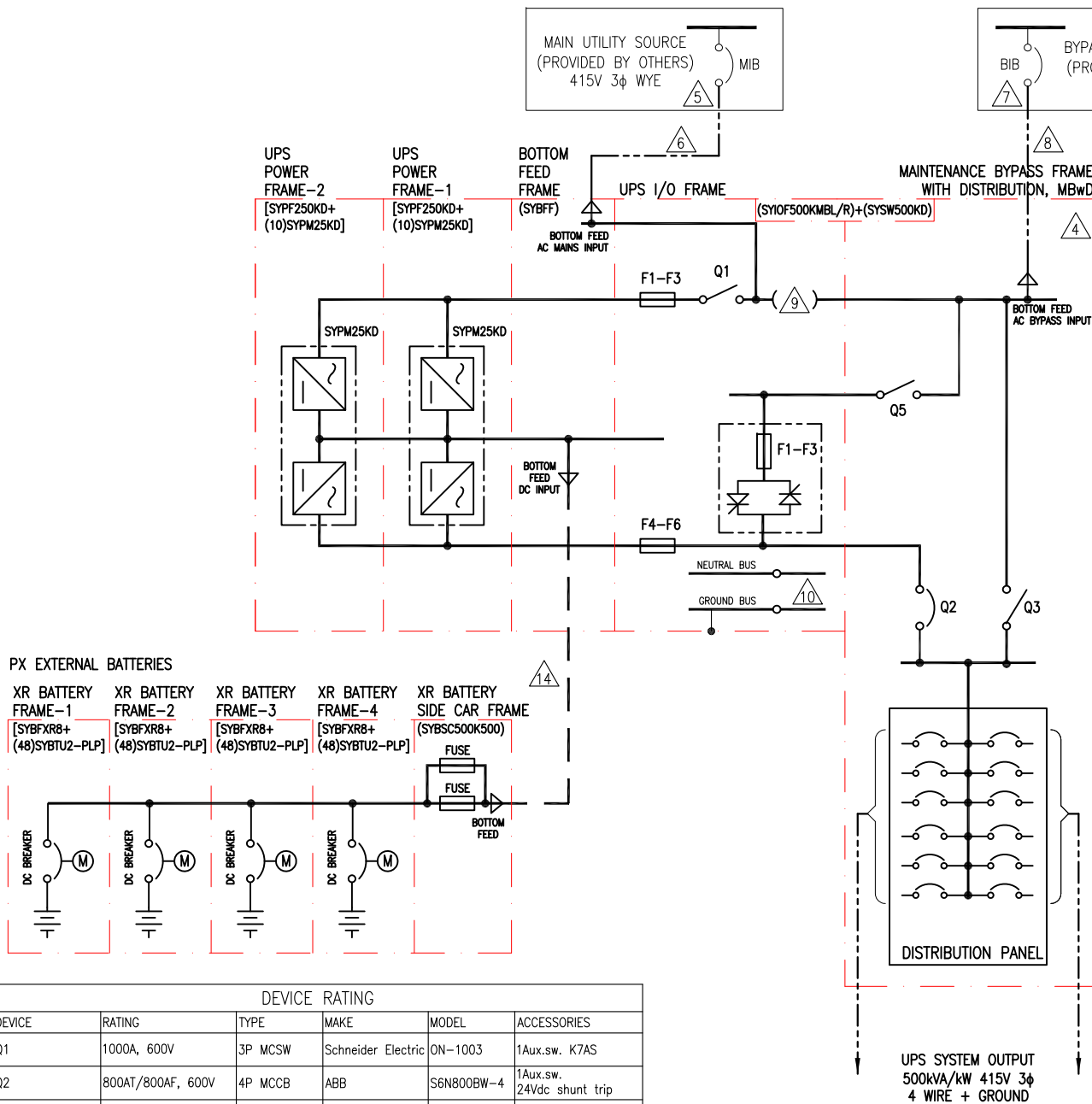

DISTRIBUTION PANEL OPTIONS			
OPTION REFERENCE	BREAKER FRAME RATING	MAX. QTY 3P	SHORT CIRCUIT CURRENT RATING
T1	100A	16	22kAIC
T3	225A	12	25kAIC
T5	400A	SEE NOTE-11	25kAIC

LEGEND:	
---	DC CABLE - PROVIDED BY OTHERS
---	AC CABLE - PROVIDED BY OTHERS

- NOTES:**
- INSTALLATION SHALL COMPLY WITH ALL APPLICABLE LOCAL AND NATIONAL CODES.
 - PLEASE REFER TO PRODUCT MANUALS FOR ADDITIONAL DETAILS.
 - DRAWING DEPICTS POWER SYSTEM CONNECTIONS AND IS NOT REPRESENTATIVE OF PHYSICAL LAYOUT, PLEASE REFER TO MECHANICAL DRAWINGS FOR PHYSICAL LAYOUT.
 - MAXIMUM RATED SHORT CIRCUIT CURRENT IS 50kA.
 - AC MAIN UTILITY SOURCE SHALL BE 415VAC, 3φ, SOLIDLY GROUND WYE, 3 WIRE+GROUND (CONTACT Schneider Electric IF OTHER). SEE SHEET 3 FOR SITE PLANNING SUBMITTAL DATA.
 - AC CABLING SHALL BE 600V RATED, 3 WIRE+GROUND.
 - AC BYPASS UTILITY SOURCE SHALL BE 415VAC, 3φ, SOLIDLY GROUND WYE, 4 WIRE+GROUND (CONTACT Schneider Electric IF OTHER). SEE SHEET 3 FOR SITE PLANNING SUBMITTAL DATA.
 - AC CABLING SHALL BE 600V RATED, 4 WIRE+GROUND.
 - SINGLE MAINS IS FACTORY DEFAULT CONFIGURATION. THE I/O FRAME TO MBWD FRAME BUS LINKS SHALL BE REMOVED FOR DUAL MAINS INSTALLATION. FOR SINGLE MAINS INSTALLATION CONTACT Schneider Electric FOR RELATED SUBMITTAL DRAWINGS.
 - THE NEUTRAL TO GROUND SYSTEM BONDING JUMPER PROVIDED BY Schneider Electric SHALL NOT BE INSTALLED FOR 4 WIRE OUTPUT CONFIGURATION. SEE INSTALLATION MANUAL FOR DETAILS.
 - MAXIMUM QUANTITY OF DISTRIBUTION BREAKERS (T5 OPTION ONLY)
 - 4 - IF THE NEUTRAL BAR KIT IS INSTALLED
 - 8 - IF THE NEUTRAL BAR KIT IS NOT INSTALLED.
 - THIS DRAWING SHOWS MINIMUM NUMBER OF BATTERY FRAMES. MAXIMUM (8) XR BATTERY FRAMES, OR THIRD PARTY BATTERIES CAN BE BAYED TO UPS. BAYING KIT IS SUPPLIED WITH THIS SOLUTION. XR BATTERY FRAME HAS MOTORIZED BREAKER.
 - BATTERY SIZING BASED ON MAXIMUM 1 VOLT DROP PER HALF-STRING AT NORMAL RATED DC CURRENT. CE SHALL ADJUST CABLE SIZE BASED ON INSTALLATION PARAMETERS.
 - DC CABLING SHALL BE 1000V RATED, 3-WIRE +GROUND. SEE SHEET 3 FOR ADDITIONAL DATA.
 - CABLE LUGS ARE NOT PROVIDED.

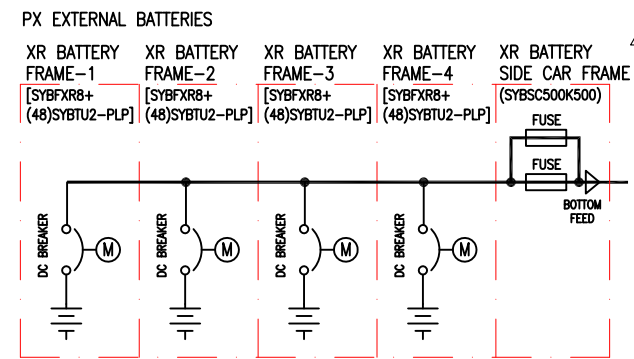

DEVICE RATING					
DEVICE	RATING	TYPE	MAKE	MODEL	ACCESSORIES
Q1	1000A, 600V	3P MCSW	Schneider Electric	ON-1003	1Aux.sw. K7AS
Q2	800AT/800AF, 600V	4P MCCB	ABB	S6N800BW-4	1Aux.sw. 24Vdc shunt trip
Q3	800A, 600V	4P MCSW	ABB	S6H800DW-4	1Aux.sw. K7AS
Q5	800A, 600V	3P MCSW	ABB	S6H800DW	1Aux.sw. K7AS
INVERTER FUSES F1-F3 / F4-F6	1250A, 700V	HIGH SPEED FUSE	BUSSMANN	170M6466	--
SSW FUSES F1-F3	1100A, 700V	HIGH SPEED FUSE	BUSSMANN	170M5167	--
DC BREAKER	400A, 600V DC	4P MCCB	ABB	1SDA06033R1	1Aux.contact, 24VDC, Shunt trip, Actuator
DC FUSES	500A, 500V DC	CLASS J	FERRAZ SHAWMUT	AJT500EI	--

THIS DRAWING AND SPECIFICATIONS HEREIN ARE THE PROPERTY OF SCHNEIDER ELECTRIC AND SHALL NOT BE COPIED, REPRODUCED OR USED IN WHOLE OR IN PART, AS THE BASIS FOR THE MANUFACTURE OR SALE OF ITEMS WITHOUT WRITTEN PERMISSION FROM SCHNEIDER ELECTRIC. THIS DRAWING IS BASED UPON LATEST AVAILABLE INFORMATION AND IS SUBJECT TO CHANGE WITHOUT NOTICE.



TITLE:	SYMMETRA PX INPUT: 415V 3φ WYE, DUAL MAINS OUTPUT: 415V 500kVA/kW BOTTOM FEED WITH EXTERNAL BATTERIES SYSTEM ONE LINE DIAGRAM	DWG NO:	SY500K500BH2C1-4W-SD	REV:	3
PROJECT: SUBMITTAL DRAWINGS	SHEET 2 OF 3	DRAWN:	V BUSH/S CUNHA/BALA	29-JUL-15	PROJ ANGLE
		ENGINEER:	C FLY/A WARNER	29-JUL-15	N.A.
		APPROVED:	B SHERIDAN	29-JUL-15	

4 WIRE OUTPUT CONFIGURATION, DUAL MAINS

UPS SYSTEM OUTPUT
500kVA/kW 415V 3φ
4 WIRE + GROUND

Symmetra® PX 250K and 500K UPS Frame Site Planning Data - 415Y/240V Dual Feed with MBwD

UPS Rating			Voltage		Mains AC Input - (MIB) ¹							Bypass AC Input - (BIB) ²							External Battery System ^{3,5}						AC Output	
					Current		Recommendations ³			Currents		Recommendations ³			Nominal VDC	Battery kW	Current @ Nom. VDC	Recommendations			Current					
UPS Frame Rating	Qty of 25kW Power Modules ⁴	kVA	kW	Input ¹	Output ²	Full Load	Max. ⁶	100% OCPD w/Electronic Trip	80% OCPD w/Electronic Trip	Cable	NOM.	Max. ⁷	100% OCPD w/Electronic Trip	80% OCPD w/Electronic Trip				Cable				100% OCPD w/Electronic Trip	80% OCPD w/Electronic Trip	Cable	NOM.	Max. ⁷
250kVA/250kW 1x 250K Frame	4	100	100	415	415	160	179	600AF/200AT	600AF/200AT	1x 3/0	139	174	600AF/150AT	600AF/150AT	1x 1/0	2x 288	104	181	600AF/200AT	600AF/200AT	1x 3/0	139	174			
	5	125	125	415	415	200	223	600AF/225AT	600AF/225AT	1x 4/0	174	217	600AF/175AT	600AF/175AT	1x 2/0	2x 288	130	226	600AF/250AT	600AF/250AT	1x 4/0	174	217			
	6	150	150	415	415	240	268	600AF/300AT	600AF/300AT	1x 300	209	261	600AF/225AT	600AF/225AT	1x 4/0	2x 288	156	271	600AF/300AT	600AF/300AT	1x 300	209	261			
	7	175	175	415	415	280	313	600AF/350AT	600AF/350AT	1x 400	243	304	600AF/250AT	600AF/250AT	1x 250	2x 288	182	316	600AF/350AT	600AF/350AT	1x 400	243	304			
	8	200	200	415	415	320	357	600AF/400AT	600AF/400AT	1x 500	278	348	600AF/300AT	600AF/300AT	1x 300	2x 288	208	362	600AF/400AT	600AF/400AT	1x 500	278	348			
	9	225	225	415	415	360	402	600AF/450AT	600AF/450AT	2 x 4/0	313	391	600AF/350AT	600AF/350AT	1x 400	2x 288	234	407	600AF/450AT	600AF/450AT	2x 4/0	313	391			
	10 ⁸	250	250	415	415	401	447	600AF/450AT	600AF/450AT	2x 4/0	348	435	600AF/350AT	600AF/350AT	1x 500	2x 288	260	452	600AF/500AT	600AF/500AT	2x 4/0	348	435			
500kVA/500kW 2x 250K Frame	11	275	275	415	415	441	491	600AF/500AT	800AF/500AT	2x 250	383	478	600AF/400AT	600AF/400AT	2x 3/0	2x 288	288	497	600AF/500AT	800AF/500AT	2x 250	383	478			
	12	300	300	415	415	481	536	600AF/600AT	800AF/600AT	2x 300	417	522	600AF/450AT	600AF/450AT	2x 4/0	2x 288	312	543	600AF/600AT	800AF/600AT	2x 300	417	522			
	13	325	325	415	415	521	581	600AF/600AT	800AF/600AT	2x 350	452	565	600AF/480AT	600AF/480AT	2x 4/0	2x 288	339	588	600AF/600AT	800AF/600AT	2x 350	452	565			
	14	350	350	415	415	561	626	800AF/700AT	1200AF/700AT	2x 400	487	609	600AF/500AT	800AF/500AT	2x 250	2x 288	365	633	800AF/640AT	800AF/640AT	2x 400	487	609			
	15	375	375	415	415	601	670	800AF/700AT	1200AF/700AT	2x 400	522	652	600AF/600AT	800AF/600AT	2x 300	2x 288	391	678	800AF/700AT	1200AF/700AT	2x 500	522	652			
	16	400	400	415	415	641	715	800AF/800AT	1200AF/800AT	2x 500	556	696	600AF/600AT	800AF/600AT	2x 300	2x 288	417	723	800AF/800AT	1200AF/800AT	2x 500	556	696			
	17	425	425	415	415	681	760	800AF/800AT	1200AF/800AT	2x 500	591	739	600AF/600AT	800AF/600AT	2x 350	2x 288	443	769	800AF/800AT	1200AF/800AT	3x 300	591	739			
	18	450	450	415	415	721	804	1200AF/900AT	1200AF/900AT	3x 350	626	783	800AF/640AT	800AF/640AT	2x 400	2x 288	469	814	1200AF/900AT	1200AF/900AT	3x 350	626	783			
	19	475	475	415	415	N/A ¹⁰	N/A ¹⁰	N/A ¹⁰	N/A ¹⁰	N/A ¹⁰	N/A ¹⁰	N/A ¹⁰	N/A ¹⁰	N/A ¹⁰	N/A ¹⁰	2x 288	495	859	1200AF/900AT	1200AF/900AT	3x 350	N/A ¹⁰	N/A ¹⁰			
	20 ⁸	500	500	415	415	N/A ¹⁰	N/A ¹⁰	N/A ¹⁰	N/A ¹⁰	N/A ¹⁰	N/A ¹⁰	N/A ¹⁰	N/A ¹⁰	N/A ¹⁰	N/A ¹⁰	2x 288	521	904	1200AF/960AT	1200AF/960AT	3x350	N/A ¹⁰	N/A ¹⁰			

Symmetra® PX

Notes.

- Mains Input source must be 415Y/240V 4-wire + Ground. Contact Schneider Electric if other.
- Output is 415Y/240V 4-wire + Ground. The bypass AC input source must be 415Y/240V 4-wire + Ground.
- Recommended cables are AWG/kcmil minimum requirement for three (3) current carrying conductors in raceway, sized for 30°C environment and 75°C terminations. All cabling must comply with installation site conditions and any applicable Local and or National Codes.
- See applicable submittal drawings for additional details.
- Contact Schneider Electric for assistance with all external battery designs. Maximum allowed DC cabling voltage drop is 1 VDC. DC cabling between the remote battery system and the UPS must be 1000V rated. Schneider Electric Standard external DCD's are rated 500A (PX 250kVA) or 1000A (PX 500kVA).
- Electronic Input Current Limit.
- This is the UPS short time rating of 125% Overload for 10 minutes. Actual short time performance may be limited by the over current protective device selected.
- For maximum scalability or future expansion it is recommended that the UPS frames be installed at their full ratings - see bold highlighted data.
- All OCPD's and cabling are by others.
- Not applicable - MBwD is determined by Q2 & Q3 rating of 800A 80% (640A).
- OCPD = Over Current Protective Device
- Final selections are responsibility of engineer of record based on installed conditions and SCC/selective coordination/arc-flash analysis.

THIS DRAWING AND SPECIFICATIONS HEREIN ARE THE PROPERTY OF SCHNEIDER ELECTRIC AND SHALL NOT BE COPIED, REPRODUCED OR USED IN WHOLE OR IN PART, AS THE BASIS FOR THE MANUFACTURE OR SALE OF ITEMS WITHOUT WRITTEN PERMISSION FROM SCHNEIDER ELECTRIC. THIS DRAWING IS BASED UPON LATEST AVAILABLE INFORMATION AND IS SUBJECT TO CHANGE WITHOUT NOTICE.



TITLE: SYMMETRA PX
INPUT: 415V 3ø WYE, DUAL MAINS
OUTPUT: 415V 500kVA/kW
SITE PLANNING SUBMITTAL DATA

PROJECT: SUBMITTAL DRAWINGS SHEET 3 OF 3

DWG NO: SY500K500BH2C1-4W-SD REV. 2

DRAWN: BALAMURUGAN 29-JUL-15
ENGINEER: A WARNER 29-JUL-15
APPROVED: B SHERIDAN 29-JUL-15

PROJ ANGLE N.A