

#### WEIGHT DETAILS

| CB RATING | CABINET           | CABINET W/PALLET  |
|-----------|-------------------|-------------------|
| 100-250A  | 135 LBS [61.0 KG] | 185 LBS [84.0 KG] |

#### CONTROL WIRING INTERCONNECT

| GALAXY 5000 |        |
|-------------|--------|
| FROM        | TO     |
| UPS (SEC1)  | MBC    |
| XM3-4       | TB11-1 |
| XM3-4       | TB11-2 |

#### NOTES:

1. INSTALLATION SHALL COMPLY WITH ALL APPLICABLE LOCAL AND NATIONAL CODES.
2. PLEASE REFER TO PRODUCT MANUALS FOR ADDITIONAL DETAILS.
3. ALL DIMENSIONS ARE IN INCHES [MILLIMETERS].
4. UNLESS OTHERWISE SPECIFIED ALL DIMENSIONS ARE TO OUTSIDE EDGE OF THE CABINET, EXCLUDING HARDWARE, CIRCUIT BREAKER HANDLE ETC.,
5. COLOR: LIGHT GRAY.
6. ALL EXTERNAL WIRING BY CUSTOMER.

THIS DRAWING AND SPECIFICATIONS HEREIN ARE THE PROPERTY OF SCHNEIDER ELECTRIC AND SHALL NOT BE COPIED, REPRODUCED OR USED IN WHOLE OR IN PART, AS THE BASIS FOR THE MANUFACTURE OR SALE OF ITEMS WITHOUT WRITTEN PERMISSION FROM SCHNEIDER ELECTRIC. THIS DRAWING IS BASED UPON LATEST AVAILABLE INFORMATION AND IS SUBJECT TO CHANGE WITHOUT NOTICE.

**Schneider Electric**

TITLE:  
GALAXY 5000  
INSTALLATION DRAWING  
MAINTENANCE BYPASS CABINET, 3-CB WALL MOUNT  
MAIN MECHANICAL

PROJECT: SUBMITTAL DRAWINGS | SHEET 1 OF 2

DWG NO: 90-160053-00

DRAWN BY: K.NAGENDRA 30-MAR-10  
ENGINEER: I. KENNEDY 28-JAN-09  
APPROVED BY: B.SHERIDAN/F.DIOSA 28-JAN-09

REV. 0  
THIRD ANGLE PROJECTION

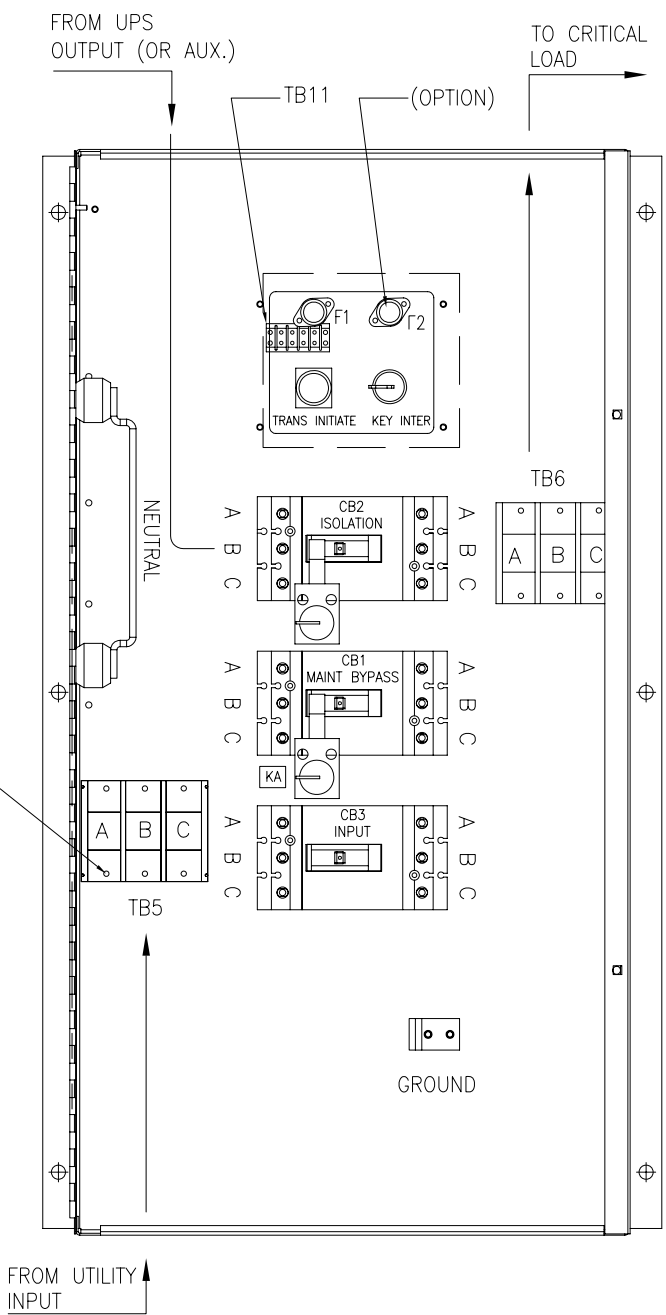

INTERNAL VIEW

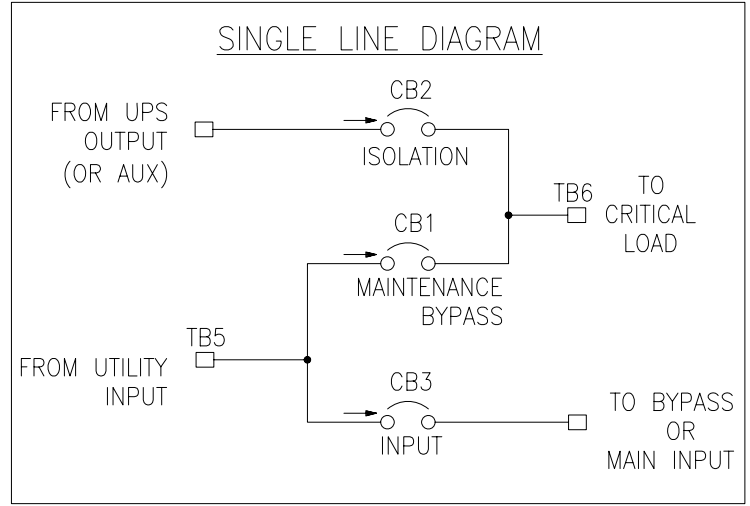
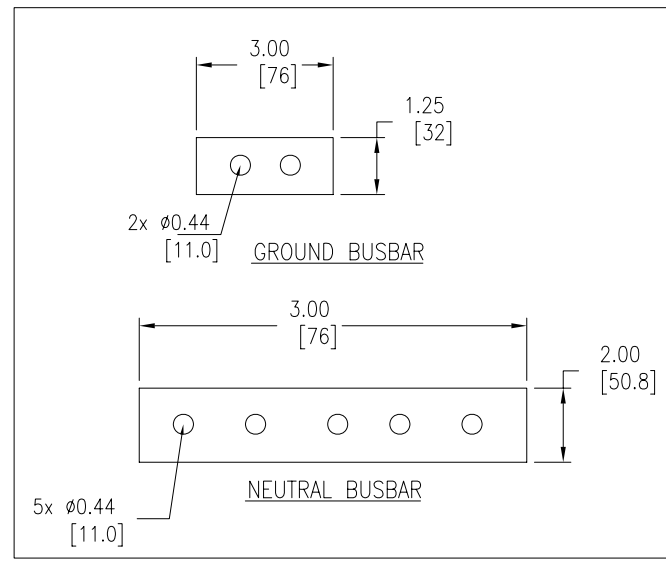

- NOTES:
1. INSTALLATION SHALL COMPLY WITH ALL APPLICABLE LOCAL AND NATIONAL CODES.
  2. PLEASE REFER TO PRODUCT MANUALS FOR ADDITIONAL DETAILS.

THIS DRAWING AND SPECIFICATIONS HEREIN ARE THE PROPERTY OF SCHNEIDER ELECTRIC AND SHALL NOT BE COPIED, REPRODUCED OR USED IN WHOLE OR IN PART, AS THE BASIS FOR THE MANUFACTURE OR SALE OF ITEMS WITHOUT WRITTEN PERMISSION FROM SCHNEIDER ELECTRIC. THIS DRAWING IS BASED UPON LATEST AVAILABLE INFORMATION AND IS SUBJECT TO CHANGE WITHOUT NOTICE.



TITLE:  
 GALAXY 5000  
 INSTALLATION DRAWING  
 MAINTENANCE BYPASS CABINET, 3-CB WALL MOUNT  
 INTERNAL VIEW & SINGLE LINE  
 PROJECT: SUBMITTAL DRAWINGS SHEET 2 OF 2

DWG NO: 90-160053-00  
 DRAWN BY: K.NAGENDRA 30-MAR-10  
 ENGINEER: I. KENNEDY 28-JAN-09  
 APPROVED BY: B.SHERIDAN/F.DIOSA 28-JAN-09

REV: 0  
 ANGLE  
 PROJECTION  
 N.A