

NOTES: UNLESS OTHERWISE SPECIFIED.

1. INSTALLATION SHALL COMPLY WITH ALL APPLICABLE LOCAL AND NATIONAL CODES.
2. PLEASE REFER TO PRODUCT MANUALS FOR ADDITIONAL DETAILS.
3. ALL DIMENSIONS ARE IN INCHES [MILLIMETERS].
4. ALL DIMENSIONS ARE TO OUTSIDE EDGE OF THE CABINET, EXCLUDING DOOR LOCK AND ALL HARDWARE.
5. COLOR: SILVER METALLIC, DARK GRAY.
6. A TORX (T-30) TYPE SCREWDRIVER IS REQUIRED TO REMOVE PANELS.
7. OPERATING TEMPERATURE: 32°F (0°C) MIN. TO 104°F (40°C) MAX.
RECOMMENDED OPERATING RANGE: 60°F (15°C) TO 77°F (25°C).
8. FOLLOW ALL APPLICABLE NEC AND LOCAL ELECTRICAL CODES.
9. POWER CABLES SHALL BE IN SEPARATE CONDUITS FROM CONTROL AND COMMUNICATION CABLES.
- △ 10. CABINET SHIPPED WITHOUT SIDE PANELS AND SIDE AIR INTAKE COVERS. USE SIDE PANEL AND AIR INTAKE COVER FROM UPS WHEN END CABINET IN SYSTEM LINE-UP.
- △ 11. RECOMMENDED CLEARANCE IS SUBJECT TO NATIONAL AND LOCAL CODES:
36.0 [914] RECOMMENDED FRONT CLEARANCE.
24.0 [610] RECOMMENDED TOP CLEARANCE FOR VENTILATION.
12. FOR SEISMIC INSTALLATION UNIT IS SHIPPED WITH CASTERS REMOVED AND SEISMIC BRACKETS ATTACHED.
13. TOTAL WEIGHT OF THE UNIT:

MODEL NUMBER	RATING	WEIGHT	VOLTAGE
72-17404X-00	40-130kVA UPS	1465 LBS [666 kg]	208V TO 600V
OPTION 85-17414X-04, 05, 06, 07			

14. POWER CABLES SHALL BE IN SEPARATE CONDUITS FROM CONTROL AND COMMUNICATION CABLES. ALL CABLE CONNECTIONS ARE BASED ON CUSTOMER SUPPLIED COPPER WIRE RATED 75°C.
- △ 15. PROVIDE ADEQUATE REAR/SIDE CLEARANCE FOR SEISMIC BRACKET INSTALLATION, IF APPLICABLE.

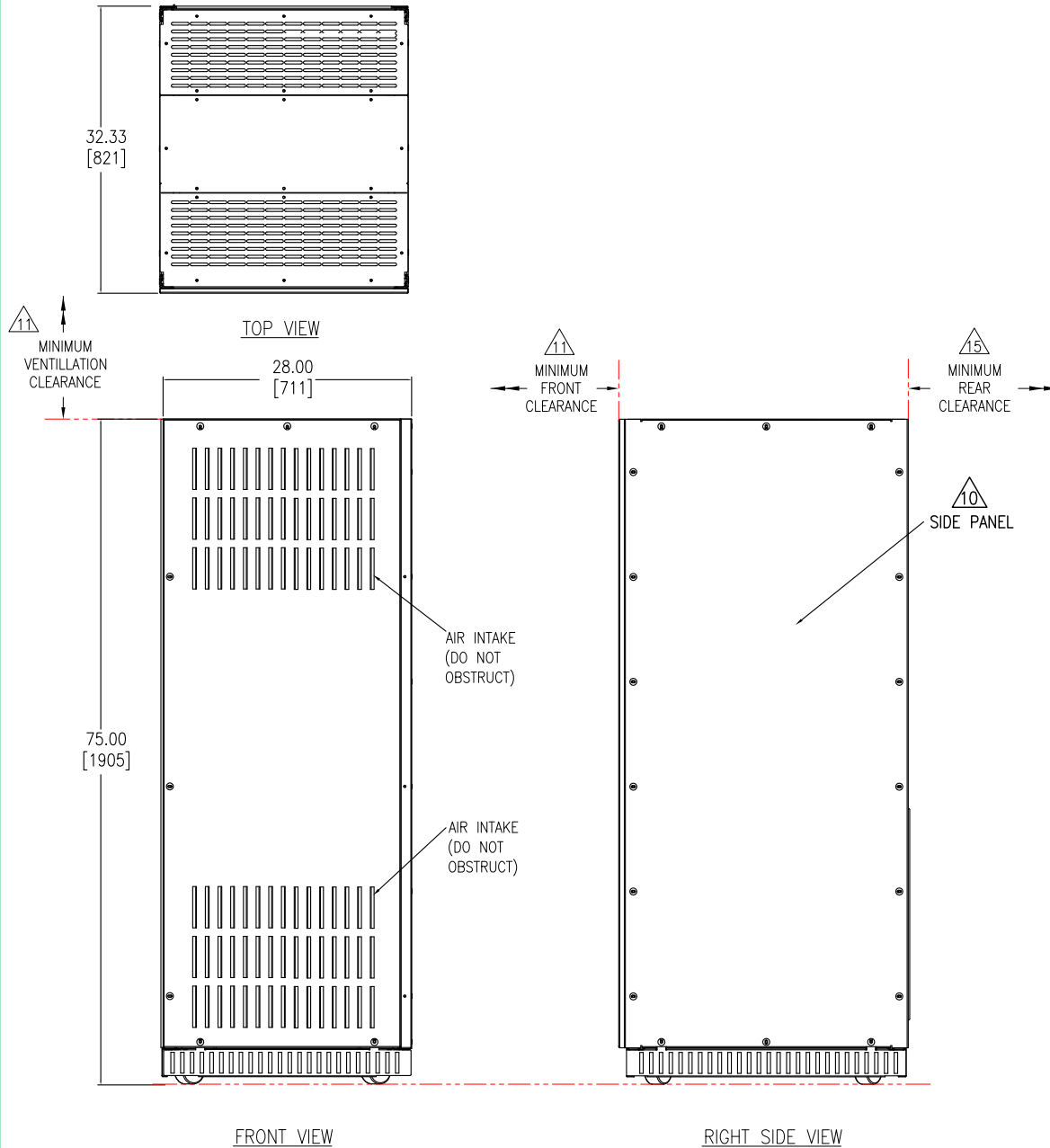

THIS DRAWING AND SPECIFICATIONS HEREIN ARE THE PROPERTY OF SCHNEIDER ELECTRIC AND SHALL NOT BE COPIED, REPRODUCED OR USED IN WHOLE OR IN PART, AS THE BASIS FOR THE MANUFACTURE OR SALE OF ITEMS WITHOUT WRITTEN PERMISSION FROM SCHNEIDER ELECTRIC. THIS DRAWING IS BASED UPON LATEST AVAILABLE INFORMATION AND IS SUBJECT TO CHANGE WITHOUT NOTICE.



TITLE: GALAXY 5000 AUXILIARY CABINETS INSTALLATION OUTPUT TRANSFORMER CABINET MAIN MECHANICAL		DWG NO: 90-174707-01	REV. 3
PROJECT: SUBMITTAL DRAWINGS	SHEET 1 OF 4	DRAWN BY: K NAGENDRA/S CUNHA	06-NOV-13
		ENGINEER: S DAS/U BHAVILAI	06-NOV-13
		APPROVED BY: J GOOSSEFF	06-NOV-13
			THIRD ANGLE PROJECTION

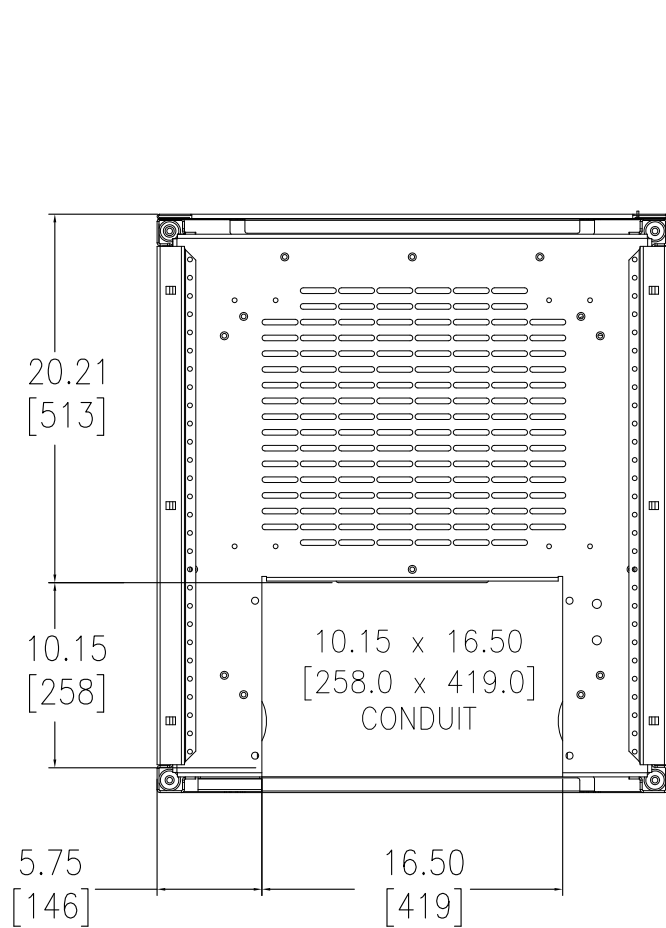

BOTTOM ENTRY CONDUIT LOCATION
BASE TOP VIEW

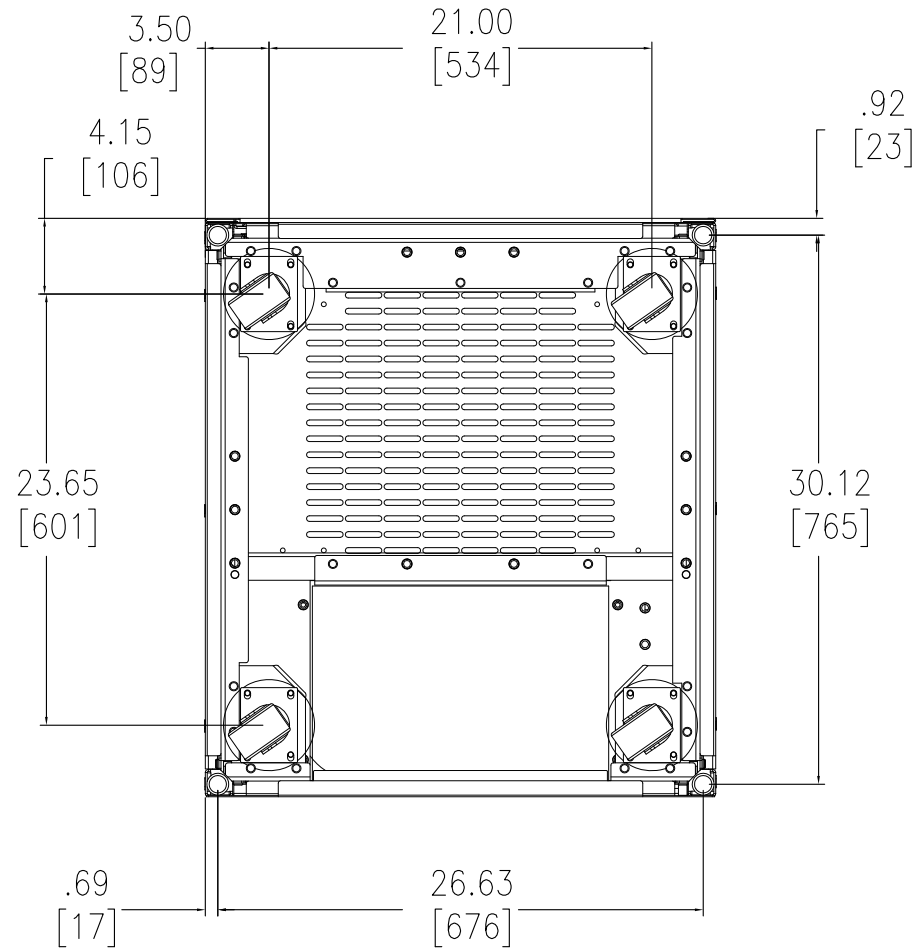

CASTER & LEVELER LOCATIONS
BASE TOP VIEW



NOTES: UNLESS OTHERWISE SPECIFIED.

1. INSTALLATION SHALL COMPLY WITH ALL APPLICABLE NATIONAL AND LOCAL CODES.
2. PLEASE REFER TO PRODUCT MANUALS FOR ADDITIONAL DETAILS.
3. ALL DIMENSIONS ARE IN INCHES [MILLIMETERS].
4. DIMENSIONS SHOWN WITHOUT SIDE PANELS {EACH SIDE PANEL 6.0 [0.24]}
- △ 5. FOR SEISMIC INSTALLATION UNIT IS SHIPPED WITH CASTERS REMOVED AND SEISMIC BRACKETS ATTACHED.

THIS DRAWING AND SPECIFICATIONS HEREIN ARE THE PROPERTY OF SCHNEIDER ELECTRIC AND SHALL NOT BE COPIED, REPRODUCED OR USED IN WHOLE OR IN PART, AS THE BASIS FOR THE MANUFACTURE OR SALE OF ITEMS WITHOUT WRITTEN PERMISSION FROM SCHNEIDER ELECTRIC. THIS DRAWING IS BASED UPON LATEST AVAILABLE INFORMATION AND IS SUBJECT TO CHANGE WITHOUT NOTICE.



TITLE:
GALAXY 5000
AUXILIARY CABINETS INSTALLATION
OUTPUT TRANSFORMER CABINET
BOTTOM VIEW & ANCHORING
PROJECT: SUBMITTAL DRAWINGS SHEET 2 OF 4

DWG NO:	90-174707-01	REV.	1
DRAWN BY:	K NAGENDRA/S CUNHA	06-NOV-13	THIRD
ENGINEER:	I KENNEDY/S DAS	06-NOV-13	ANGLE
APPROVED BY:	J GOOSSEFF	06-NOV-13	PROJECTION

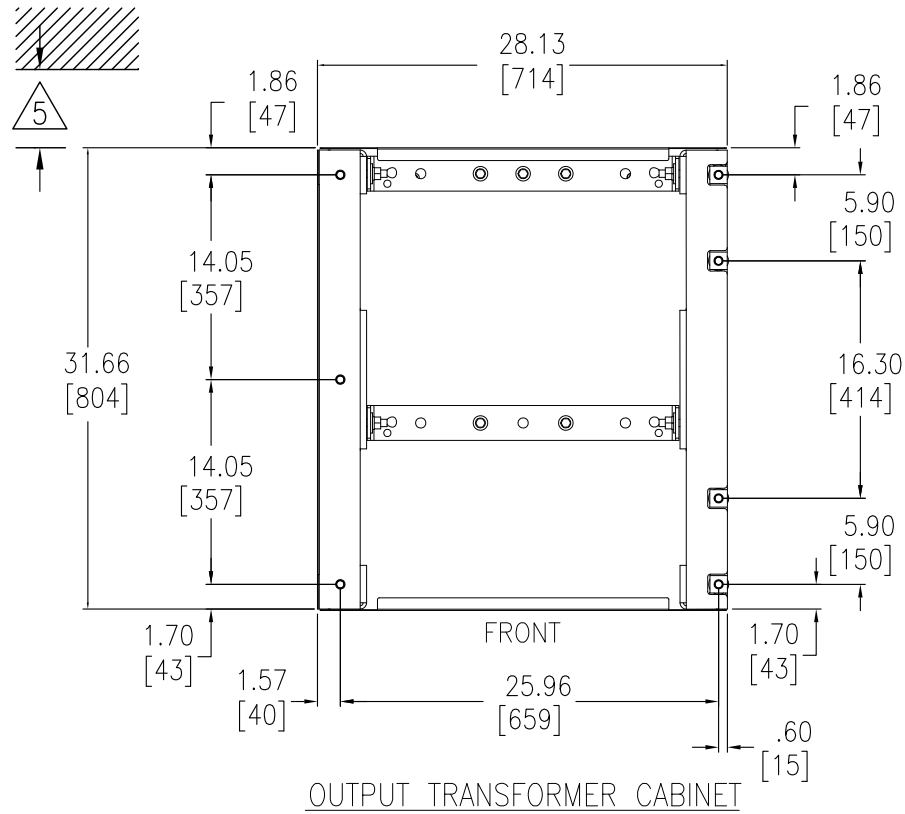

SEISMIC ANCHORING

NOTES: UNLESS OTHERWISE SPECIFIED

1. INSTALLATION SHALL COMPLY WITH ALL APPLICABLE NATIONAL AND LOCAL CODES.
2. PLEASE REFER TO PRODUCT MANUALS FOR ADDITIONAL DETAILS.
3. UNLESS OTHERWISE SPECIFIED, ALL DIMENSIONS ARE IN INCHES [MILLIMETERS].
4. ALL DIMENSIONS ARE TO THE OUTSIDE EDGE OF CABINET, EXCLUDING DOOR LOCKS AND ALL HARDWARE.
- △ 5. 4" [101.6 MM] MINIMUM CLEARANCE FROM THE REAR PANEL OF UNIT TO THE WALL. ADDITIONAL CLEARANCE (BY CUSTOMER) DEPENDENT OF FLOOR ANCHORING HARDWARE SPECIFICATIONS.
6. FLOOR ANCHORING HARDWARE IS NOT PROVIDED.
MINIMUM REQUIREMENT FOR MBC CABINET 1/2", 5 GRADE HARDWARE.
7. SEISMIC QUALIFICATION OF NON-STRUCTURAL COMPONENT BY SCHNEIDER ELECTRIC IS JUST ONE LINK IN THE TOTAL CHAIN OF RESPONSIBILITY REQUIRED TO MAXIMIZE THE PROBABILITY THAT THE EQUIPMENT WILL BE INTACT AND FUNCTIONAL AFTER A SEISMIC EVENT. DURING A SEISMIC EVENT THE EQUIPMENT MUST BE ABLE TO TRANSFER THE LOADS THAT ARE CREATED THROUGH THE MOUNTING AND ANCHORAGE TO THE LOAD-BEARING PATH OF THE BUILDING STRUCTURAL SYSTEM. ANCHORAGE OF THE EQUIPMENT TO THE PRIMARY BUILDING STRUCTURE IS REQUIRED TO VALIDATE THE SEISMIC CERTIFICATION. THE STRUCTURAL ENGINEER OR DESIGN ENGINEER OF RECORD IS RESPONSIBLE FOR DETAILING THE EQUIPMENT ANCHORAGE REQUIREMENTS FOR THE GIVEN INSTALLATION. THE INSTALLER AND MANUFACTURERS OF THE ANCHORAGE SYSTEM ARE RESPONSIBLE FOR ASSURING THAT THE MOUNTING REQUIREMENTS ARE MET. SCHNEIDER ELECTRIC IS NOT RESPONSIBLE FOR THE SPECIFICATION AND PERFORMANCE OF THE ANCHORAGE SYSTEMS.

REFERENCE P/N		
DESCRIPTION	KIT NUMBER	QTY.
TRANSFORMER	OH-0735	1

SEISMIC INSTALLATION ONLY

THIS DRAWING AND SPECIFICATIONS HEREIN ARE THE PROPERTY OF SCHNEIDER ELECTRIC AND SHALL NOT BE COPIED, REPRODUCED OR USED IN WHOLE OR IN PART, AS THE BASIS FOR THE MANUFACTURE OR SALE OF ITEMS WITHOUT WRITTEN PERMISSION FROM SCHNEIDER ELECTRIC. THIS DRAWING IS BASED UPON LATEST AVAILABLE INFORMATION AND IS SUBJECT TO CHANGE WITHOUT NOTICE.



TITLE:		DWG NO:		REV.
GALAXY 5000 AUXILIARY CABINETS INSTALLATION OUTPUT TRANSFORMER CABINET SEISMIC ANCHORING CONFIGURATION		90-174707-01		0
PROJECT: SUBMITTAL DRAWINGS		DRAWN BY:	S CUNHA	06-NOV-13
SHEET 3 OF 4		ENGINEER:	C PARENTI	06-NOV-13
		APPROVED BY:	J GOOSSEFF/S DAS	06-NOV-13
				THIRD ANGLE PROJECTION

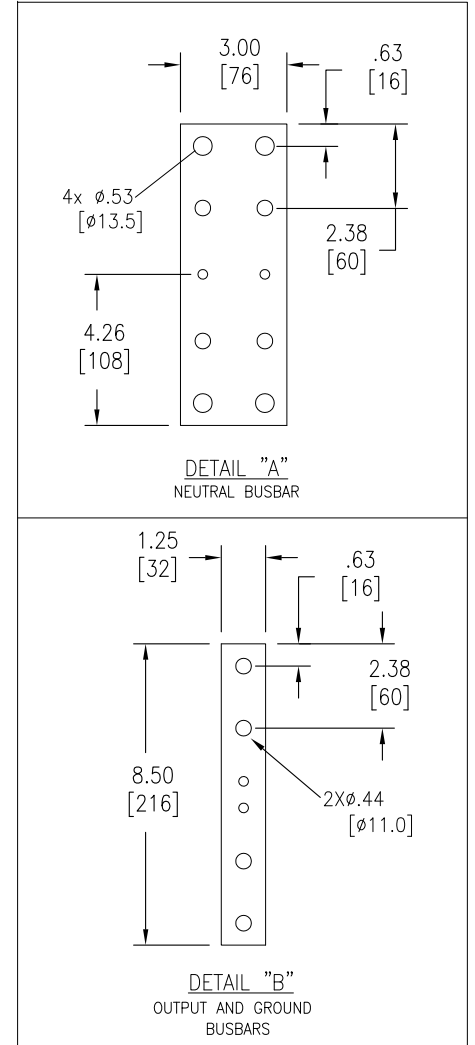
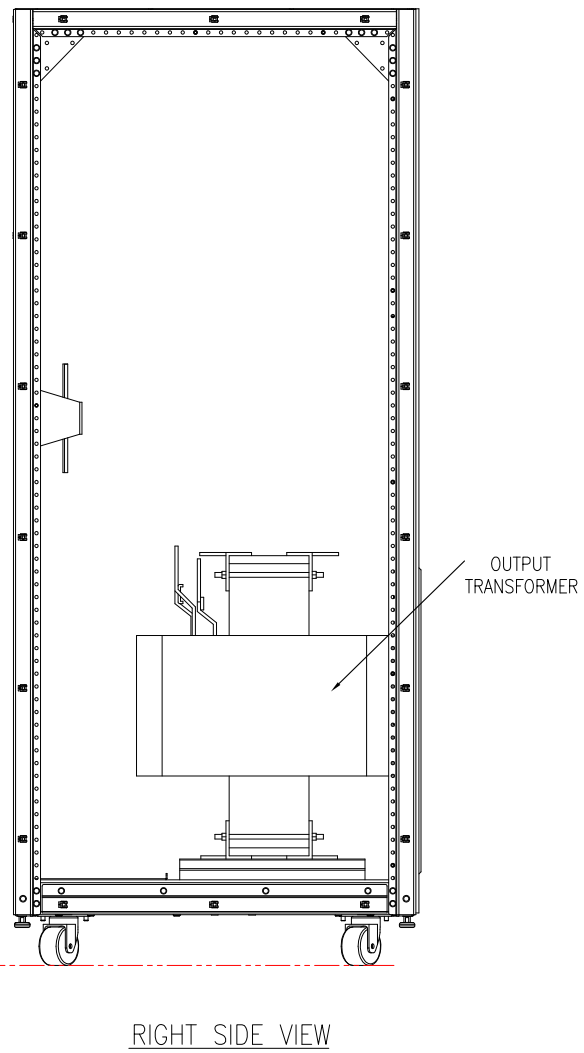
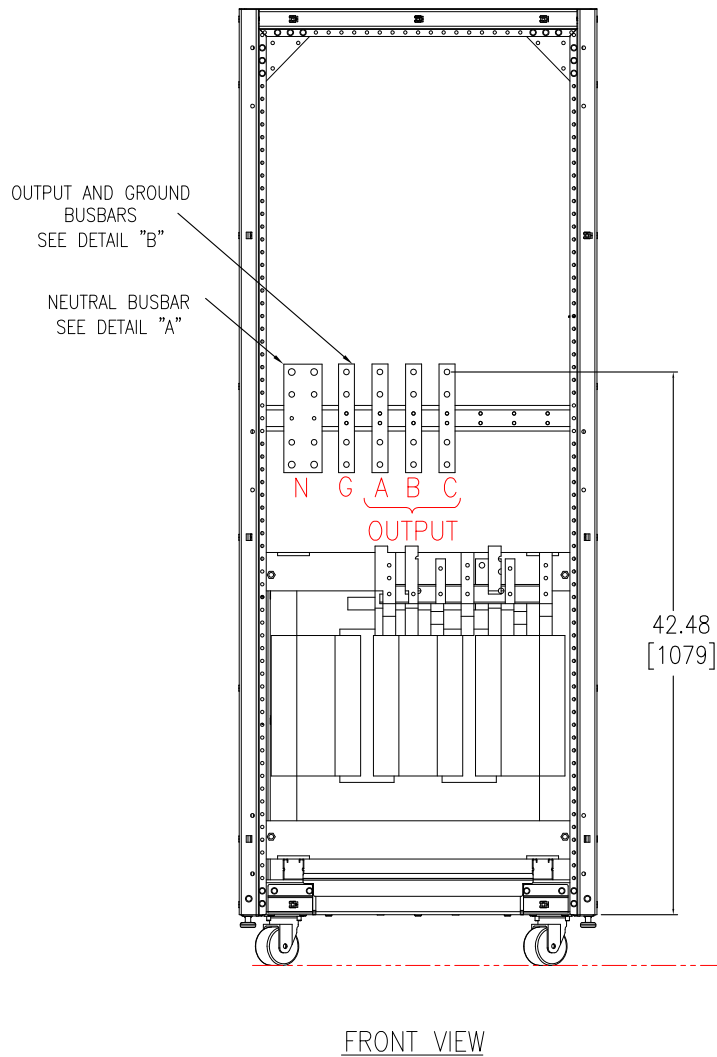

NOTES: UNLESS OTHERWISE SPECIFIED.

1. INSTALLATION SHALL COMPLY WITH ALL APPLICABLE NATIONAL AND LOCAL CODES.
2. PLEASE REFER TO PRODUCT MANUALS FOR ADDITIONAL DETAILS.
3. ALL DIMENSIONS ARE IN INCHES [MILLIMETERS].
4. FOR SEISMIC INSTALLATION UNIT IS SHIPPED WITH CASTERS REMOVED AND SEISMIC BRACKETS ATTACHED.

THIS DRAWING AND SPECIFICATIONS HEREIN ARE THE PROPERTY OF SCHNEIDER ELECTRIC AND SHALL NOT BE COPIED, REPRODUCED OR USED IN WHOLE OR IN PART, AS THE BASIS FOR THE MANUFACTURE OR SALE OF ITEMS WITHOUT WRITTEN PERMISSION FROM SCHNEIDER ELECTRIC. THIS DRAWING IS BASED UPON LATEST AVAILABLE INFORMATION AND IS SUBJECT TO CHANGE WITHOUT NOTICE.



TITLE:
GALAXY 5000
AUXILIARY CABINETS INSTALLATION
OUTPUT TRANSFORMER CABINET
INTERNAL VIEW

PROJECT: SUBMITTAL DRAWINGS SHEET 4 OF 4

DWG NO: 90-174707-01

DRAWN BY: K NAGENDRA/S CUNHA 06-NOV-13

ENGINEER: I KENNEDY/S DAS 06-NOV-13

APPROVED BY: J GOOSSEFF 06-NOV-13

REV. 1

THIRD

ANGLE

PROJECTION