

TOP VIEW

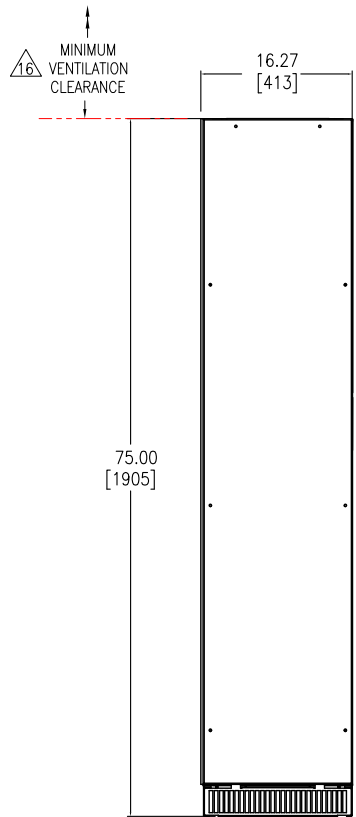

FRONT VIEW

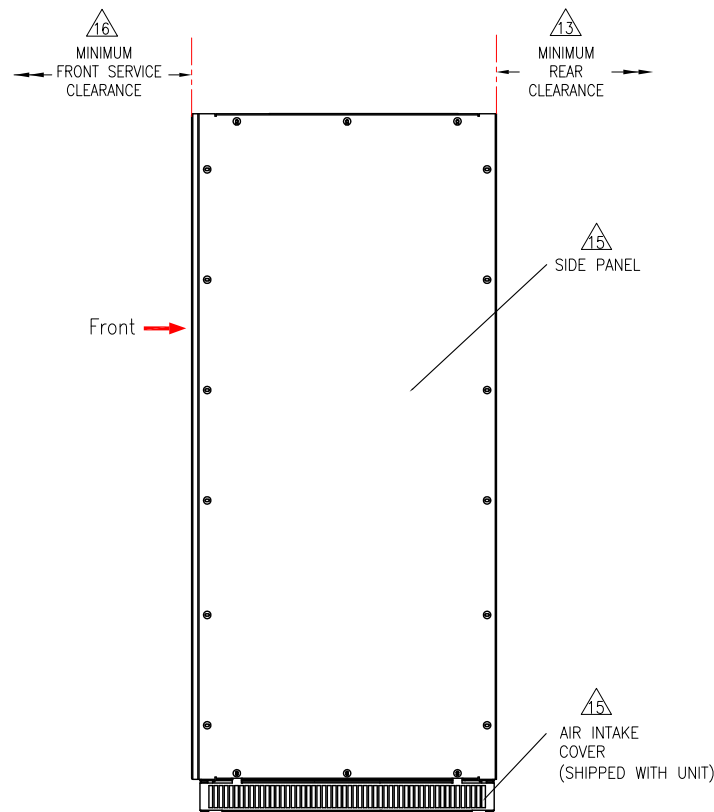

SIDE VIEW

NOTES:

1. INSTALLATION SHALL COMPLY WITH ALL APPLICABLE LOCAL AND NATIONAL CODES.
2. PLEASE REFER TO PRODUCT MANUALS FOR ADDITIONAL DETAILS.
3. ALL DIMENSIONS ARE IN INCHES [MILLIMETERS].
4. TOTAL WEIGHT OF UNIT IS:

Model Number	Cabinet Weight (Max.)
72-174000-00	180 LBS [81.82 kg]
72-174000-10	180 LBS [81.82 kg]

5. CABLE ENTRY IS FROM TOP/BOTTOM OF THE UNIT.
6. ALL DIMENSIONS ARE TO OUTSIDE EDGE OF THE CABINET, EXCLUDING DOOR LOCK AND ALL HARDWARE.
7. COLOR: SILVER METALLIC, DARK GRAY.
8. A TORX (T-30) TYPE SCREWDRIVER IS REQUIRED TO REMOVE PANELS.
9. OPERATING TEMPERATURE: 32°F (0°C) MIN. TO 104°F (40°C) MAX. RECOMMENDED OPERATING RANGE: 60°F (15°C) TO 77°F (25°C).
10. REFER TO DOCUMENT NO. 9-00038-00 FOR CABLE PREPARATION PROCEDURE FOR FIELD WIRING.
11. ALL EXTERNAL WIRING SUPPLIED AND CONNECTED BY CUSTOMER. (STAND ALONE MODELS ONLY). FOLLOW ALL APPLICABLE NEC AND LOCAL ELECTRICAL CODES.
12. POWER CABLES SHALL BE IN SEPARATE CONDUITS FROM CONTROL AND COMMUNICATION CABLES. ALL CABLE CONNECTIONS ARE BASED ON CUSTOMER SUPPLIED COPPER WIRE RATED 75°C.
- △13. PROVIDE ADEQUATE REAR/SIDE CLEARANCE FOR SEISMIC BRACKET INSTALLATION, IF APPLICABLE.
14. FOR SEISMIC INSTALLATION UNIT IS SHIPPED WITH CASTERS REMOVED AND SEISMIC BRACKETS ATTACHED.
- △15. FOR ADJACENT UNIT: CABINET SHIPPED WITHOUT SIDE PANELS AND SIDE AIR INTAKE COVERS. USE SIDE PANEL AND AIR INTAKE COVER FROM UPS WHEN END CABINET IN SYSTEM LINE-UP.
- △16. RECOMMENDED CLEARANCE IS SUBJECT TO NATIONAL AND LOCAL CODES: 36.0 [914] RECOMMENDED FRONT CLEARANCE. 24.0 [610] RECOMMENDED TOP CLEARANCE FOR VENTILATION.

THIS DRAWING AND SPECIFICATIONS HEREIN ARE THE PROPERTY OF SCHNEIDER ELECTRIC AND SHALL NOT BE COPIED, REPRODUCED OR USED IN WHOLE OR IN PART, AS THE BASIS FOR THE MANUFACTURE OR SALE OF ITEMS WITHOUT WRITTEN PERMISSION FROM SCHNEIDER ELECTRIC. THIS DRAWING IS BASED UPON LATEST AVAILABLE INFORMATION AND IS SUBJECT TO CHANGE WITHOUT NOTICE.



TITLE:  
GALAXY 5000  
AUXILIARY CABINETS INSTALLATION  
TOP/BOTTOM ENTRY CABINET-16in W(Single/Parallel)  
MAIN MECHANICAL

PROJECT: SUBMITTAL DRAWINGS SHEET 1 OF 4

DWG NO: 90-174702-00 REV. 3

DRAWN BY: K NAGENDRA/S CUNHA	06-NOV-13	THIRD
ENGINEER: S DAS/U BHAVILAI	06-NOV-13	ANGLE
APPROVED BY: J GOOSSEFF	06-NOV-13	PROJECTION

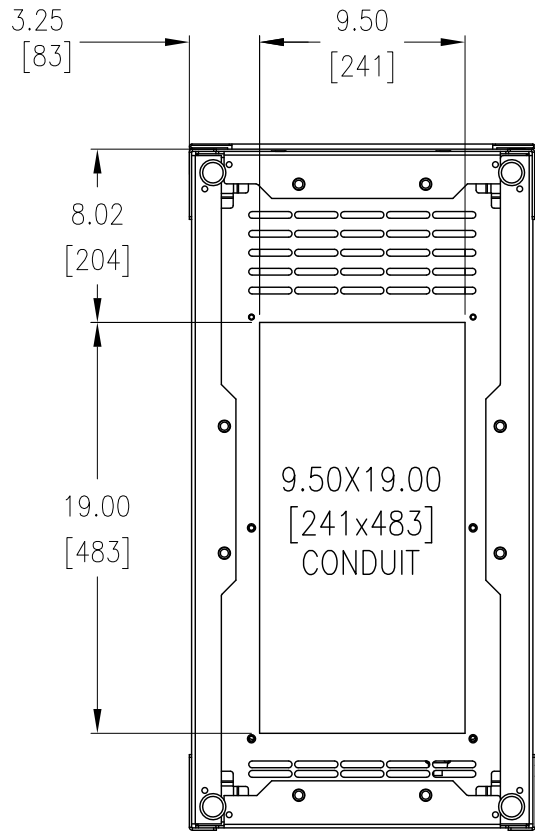

BOTTOM ENTRY CONDUIT LOCATION  
BASE TOP VIEW

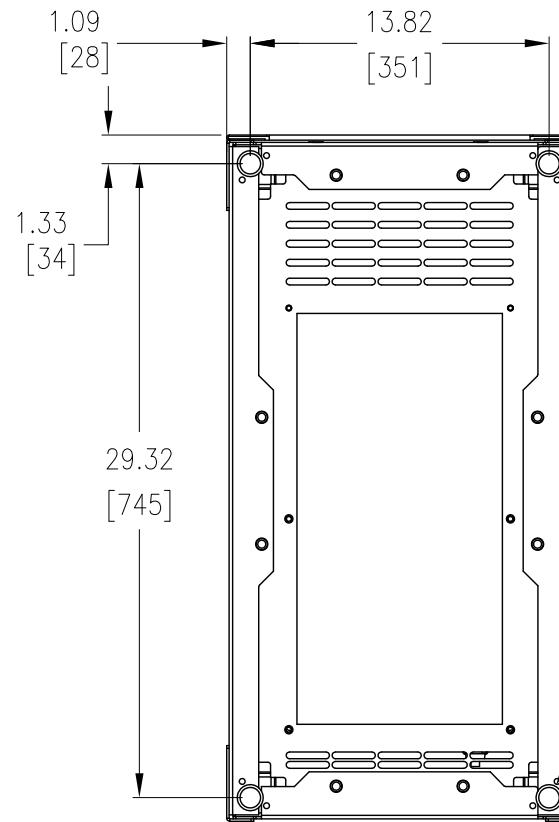

LEVELER LOCATIONS  
BASE TOP VIEW

NOTES: UNLESS OTHERWISE SPECIFIED.

1. INSTALLATION SHALL COMPLY WITH ALL APPLICABLE NATIONAL AND LOCAL CODES.
2. PLEASE REFER TO PRODUCT MANUALS FOR ADDITIONAL DETAILS.
3. ALL DIMENSIONS ARE IN INCHES [MILLIMETERS].
4. DIMENSIONS SHOWN WITHOUT SIDE PANELS {EACH SIDE PANEL 6.0 [0.24]}
- △ 5. FOR SEISMIC INSTALLATION UNIT IS SHIPPED WITH CASTERS REMOVED AND SEISMIC BRACKETS ATTACHED.

THIS DRAWING AND SPECIFICATIONS HEREIN ARE THE PROPERTY OF SCHNEIDER ELECTRIC AND SHALL NOT BE COPIED, REPRODUCED OR USED IN WHOLE OR IN PART, AS THE BASIS FOR THE MANUFACTURE OR SALE OF ITEMS WITHOUT WRITTEN PERMISSION FROM SCHNEIDER ELECTRIC. THIS DRAWING IS BASED UPON LATEST AVAILABLE INFORMATION AND IS SUBJECT TO CHANGE WITHOUT NOTICE.



TITLE:  
GALAXY 5000  
AUXILIARY CABINETS INSTALLATION  
TOP/BOTTOM ENTRY CABINET-16in W(Single/Parallel)  
BOTTOM VIEW & ANCHORING  
PROJECT: SUBMITTAL DRAWINGS SHEET 2 OF 4

DWG NO: 90-174702-00  
DRAWN BY: K NAGENDRA/S CUNHA 06-NOV-13  
ENGINEER: I KENNEDY/S DAS 06-NOV-13  
APPROVED BY: J GOOSSEFF 06-NOV-13

REV. 1  
THIRD ANGLE PROJECTION

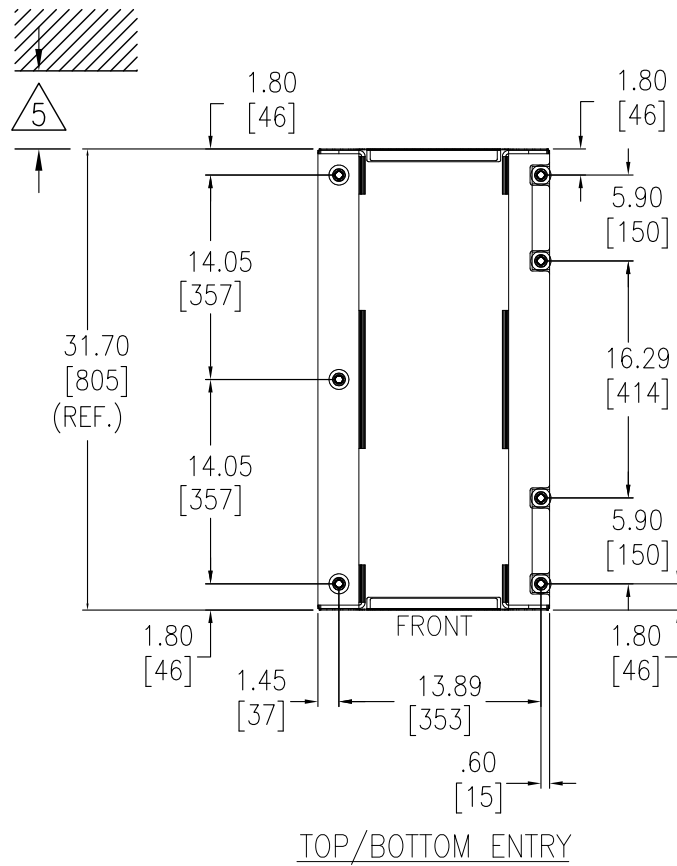

SEISMIC ANCHORING

NOTES: UNLESS OTHERWISE SPECIFIED

1. INSTALLATION SHALL COMPLY WITH ALL APPLICABLE NATIONAL AND LOCAL CODES.
2. PLEASE REFER TO PRODUCT MANUALS FOR ADDITIONAL DETAILS.
3. UNLESS OTHERWISE SPECIFIED, ALL DIMENSIONS ARE IN INCHES [MILLIMETERS].
4. ALL DIMENSIONS ARE TO THE OUTSIDE EDGE OF CABINET, EXCLUDING DOOR LOCKS AND ALL HARDWARE.
- △ 5. 4" [101.6 MM] MINIMUM CLEARANCE FROM THE REAR PANEL OF UNIT TO THE WALL. ADDITIONAL CLEARANCE (BY CUSTOMER) DEPENDENT OF FLOOR ANCHORING HARDWARE SPECIFICATIONS.
6. FLOOR ANCHORING HARDWARE IS NOT PROVIDED.  
MINIMUM REQUIREMENT FOR MBC CABINET 1/2", 5 GRADE HARDWARE.
7. SEISMIC QUALIFICATION OF NON-STRUCTURAL COMPONENT BY SCHNEIDER ELECTRIC IS JUST ONE LINK IN THE TOTAL CHAIN OF RESPONSIBILITY REQUIRED TO MAXIMIZE THE PROBABILITY THAT THE EQUIPMENT WILL BE INTACT AND FUNCTIONAL AFTER A SEISMIC EVENT. DURING A SEISMIC EVENT THE EQUIPMENT MUST BE ABLE TO TRANSFER THE LOADS THAT ARE CREATED THROUGH THE MOUNTING AND ANCHORAGE TO THE LOAD-BEARING PATH OF THE BUILDING STRUCTURAL SYSTEM. ANCHORAGE OF THE EQUIPMENT TO THE PRIMARY BUILDING STRUCTURE IS REQUIRED TO VALIDATE THE SEISMIC CERTIFICATION. THE STRUCTURAL ENGINEER OR DESIGN ENGINEER OF RECORD IS RESPONSIBLE FOR DETAILING THE EQUIPMENT ANCHORAGE REQUIREMENTS FOR THE GIVEN INSTALLATION. THE INSTALLER AND MANUFACTURERS OF THE ANCHORAGE SYSTEM ARE RESPONSIBLE FOR ASSURING THAT THE MOUNTING REQUIREMENTS ARE MET. SCHNEIDER ELECTRIC IS NOT RESPONSIBLE FOR THE SPECIFICATION AND PERFORMANCE OF THE ANCHORAGE SYSTEMS.

REFERENCE P/N		
DESCRIPTION	KIT NUMBER	QTY.
TOP/BOTTOM ENTRY	OH-0734	1

**SEISMIC INSTALLATION ONLY**

THIS DRAWING AND SPECIFICATIONS HEREIN ARE THE PROPERTY OF SCHNEIDER ELECTRIC AND SHALL NOT BE COPIED, REPRODUCED OR USED IN WHOLE OR IN PART, AS THE BASIS FOR THE MANUFACTURE OR SALE OF ITEMS WITHOUT WRITTEN PERMISSION FROM SCHNEIDER ELECTRIC. THIS DRAWING IS BASED UPON LATEST AVAILABLE INFORMATION AND IS SUBJECT TO CHANGE WITHOUT NOTICE.



TITLE:  
GALAXY 5000  
AUXILIARY CABINETS INSTALLATION  
TOP/BOTTOM ENTRY CABINET-16in W(Single/Parallel)  
SEISMIC ANCHORING CONFIGURATION

PROJECT: SUBMITTAL DRAWINGS SHEET 3 OF 4

DWG NO:	90-174702-00	REV.	0
DRAWN BY:	S CUNHA	06-NOV-13	THIRD
ENGINEER:	C PARENTI	06-NOV-13	ANGLE
APPROVED BY:	S DAS/J GOOSSEFF	06-NOV-13	PROJECTION

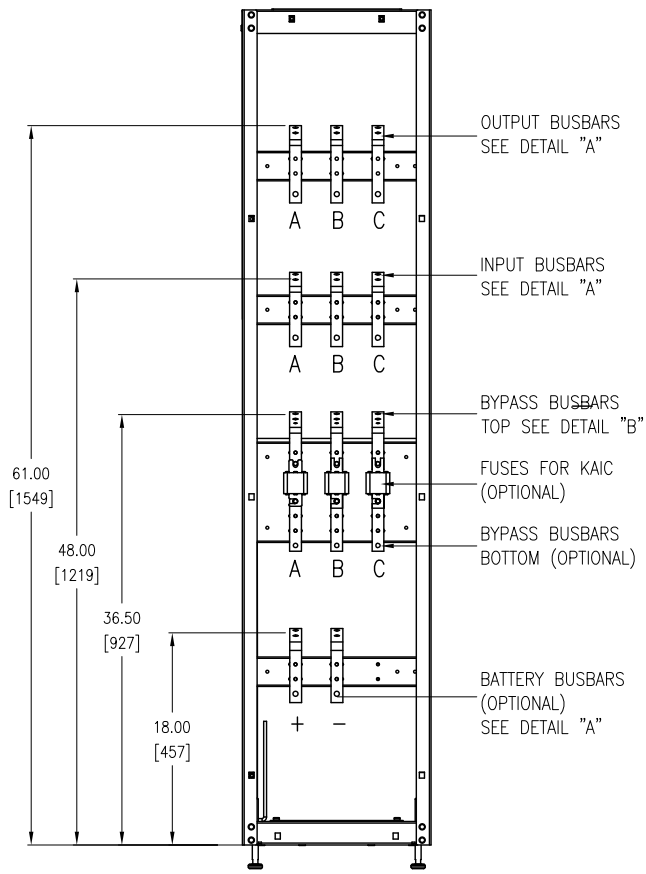

FRONT VIEW  
TOP ENTRY

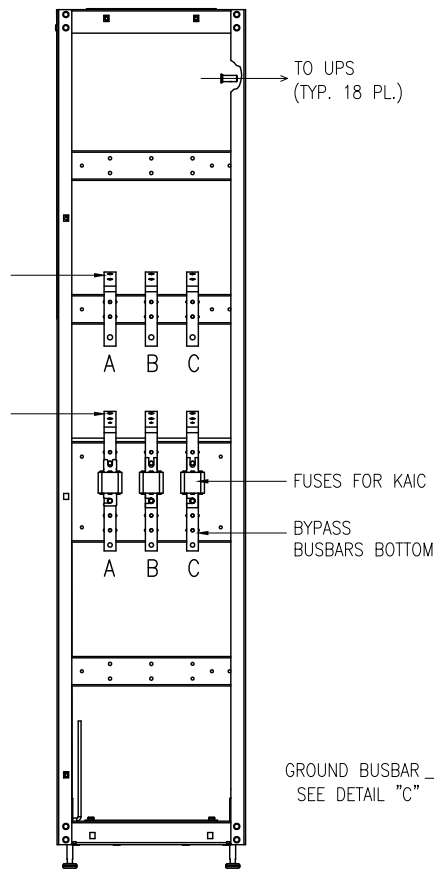

FRONT VIEW  
BOTTOM ENTRY

ATTACH CABINET TO UPS  
USING M6 SCREW,  
18 PL. PROVIDED.

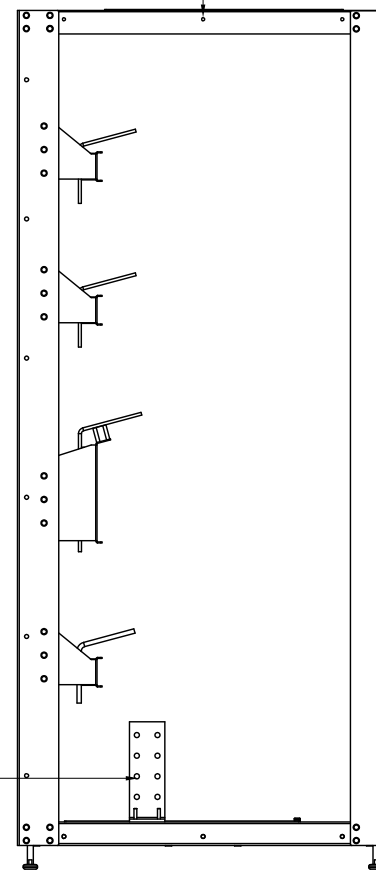

SIDE VIEW

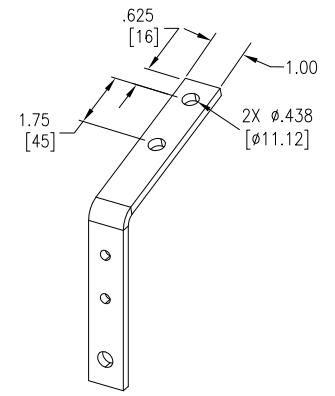

DETAIL "A"  
INPUT, OUTPUT AND  
BATTERY BUSBARS

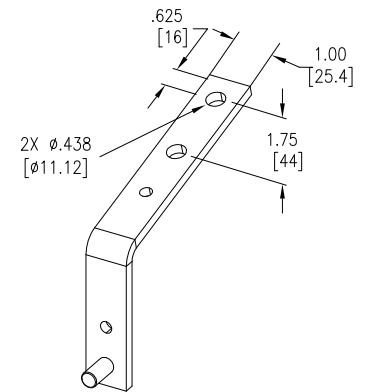

DETAIL "B"  
BYPASS BUSBARS TOP

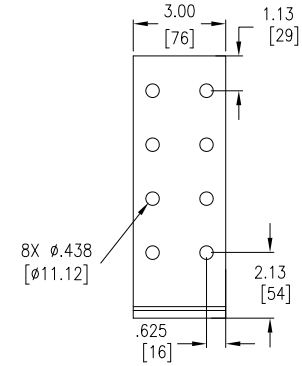

DETAIL "C"  
GROUND BUSBAR

NOTES: UNLESS OTHERWISE SPECIFIED.

1. INSTALLATION SHALL COMPLY WITH ALL APPLICABLE NATIONAL AND LOCAL CODES.
2. PLEASE REFER TO PRODUCT MANUALS FOR ADDITIONAL DETAILS.
3. ALL DIMENSIONS ARE IN INCHES [MILLIMETERS].
4. FOR SEISMIC INSTALLATION UNIT IS SHIPPED WITH CASTERS REMOVED AND SEISMIC BRACKETS ATTACHED.

THIS DRAWING AND SPECIFICATIONS HEREIN ARE THE PROPERTY OF SCHNEIDER ELECTRIC AND SHALL NOT BE COPIED, REPRODUCED OR USED IN WHOLE OR IN PART, AS THE BASIS FOR THE MANUFACTURE OR SALE OF ITEMS WITHOUT WRITTEN PERMISSION FROM SCHNEIDER ELECTRIC. THIS DRAWING IS BASED UPON LATEST AVAILABLE INFORMATION AND IS SUBJECT TO CHANGE WITHOUT NOTICE.

**Schneider**  
Electric

TITLE:  
GALAXY 5000  
AUXILIARY CABINETS INSTALLATION  
TOP/BOTTOM ENTRY CABINET-16in W(Single/Parallel)  
INTERNAL VIEW  
PROJECT: SUBMITTAL DRAWINGS SHEET 4 OF 4

DWG NO: 90-174702-00  
DRAWN BY: K NAGENDRA/S CUNHA 06-NOV-13  
ENGINEER: I KENNEDY/S DAS 06-NOV-13  
APPROVED BY: J GOOSSEFF 06-NOV-13

REV. 1  
THIRD ANGLE PROJECTION