

MAINTENANCE BYPASS PANEL(MBP)

△ MANS INPUT
(PROVIDED BY OTHERS)
3x400/230V, 50Hz
L1,L2,L3,N,PE

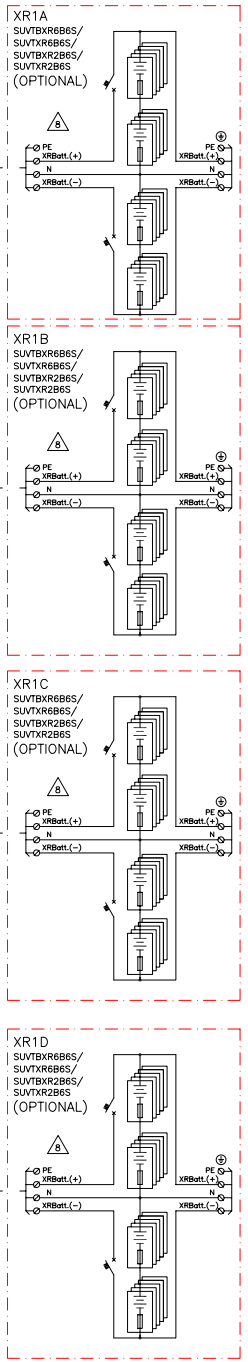
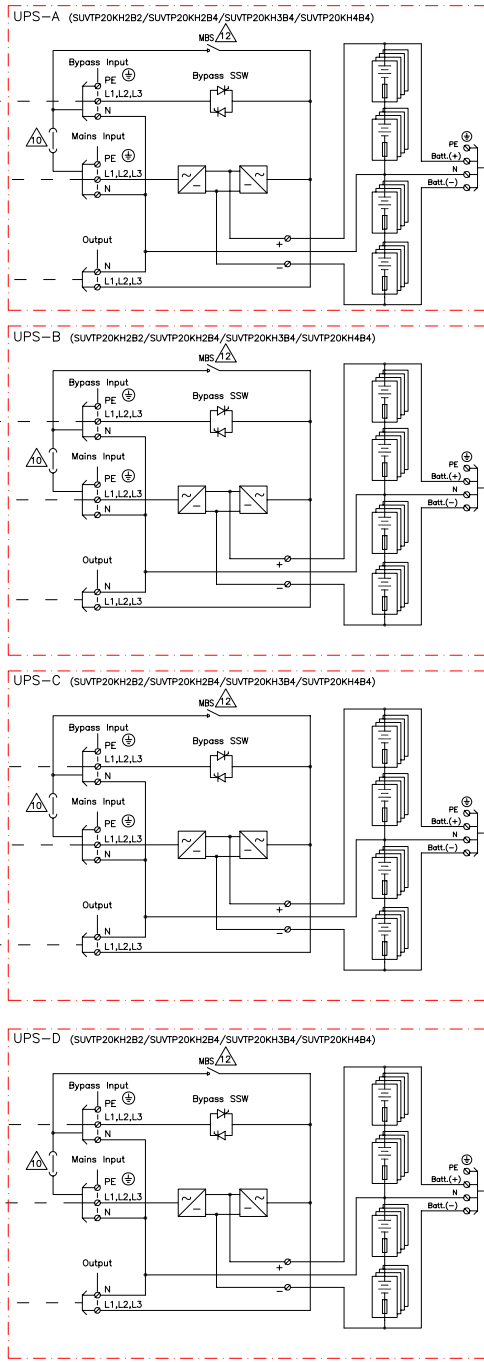
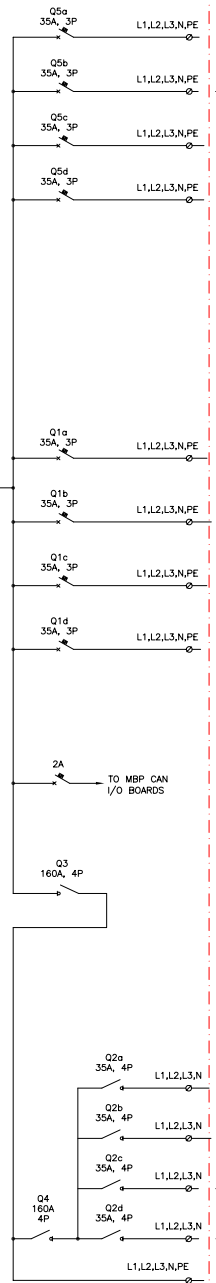

- NOTES:
- PLEASE REFER TO PRODUCT MANUALS FOR DETAILS.
 - MUST BE L1,L2,L3,N,PE SOURCE PROVIDED BY OTHERS.
 - = AC/DC CABLING PROVIDED BY OTHERS.
 - ALL AC POWER CABLING IS L1,L2,L3,N,PE.
 - DC CABLING SHOULD BE SEGREGATED FROM AC CABLING SEE BATTERY INSTALLATION INFORMATION
 - UPS INPUT AND OUTPUT CABLES SHOULD BE SEGREGATED
 - POWER WIRING AND CONTROL WIRING SHOULD BE SEGREGATED
 - XR BATTERY CABINET IS AVAILABLE WITHOUT BREAKER, WITH DC FUSES ONLY
 - XR BATTERY CABINET CAN BE BAYED TO UPS. BAYING KIT HAS TO BE PURCHASED AS AN OPTION.
 - UP TO 4 XR BATTERY CABINETS CAN BE CONNECTED TO UPS TO EXTEND BACKUP TIME
 - FOR DUAL MAINS INSTALLATION 3 BRIDGE BUS BARS BETWEEN MAIN AND BYPASS INPUTS HAVE TO BE REMOVED
 - OUTPUT OVERCURRENT PROTECTION MUST BE PROVIDED BY OTHERS. RECOMMENDED OUTPUT BREAKER RATING 160A
 - MBS HAS TO BE DISABLED WHILE USING WITH MAINTENANCE BYPASS PANEL.
 - THIS DRAWING SHOWS MAXIMUM NUMBER OF BATTERY MODULES IN EACH CABINET. THE QUANTITY OF BATTERY MODULE IS SKU SPECIFIC.
EX. SUVTPxxKH1B4
CAN BE EXPANDED UP TO (4) BATTERY MODULES
MINIMUM NUMBER (1) OF BATTERY MODULES.
 - EX. SUVTBXR2B6S
CAN BE EXPANDED UP TO (6) BATTERY MODULES.
MINIMUM NUMBER (2) OF BATTERY MODULES.
 - INSTALLATION MUST COMPLY WITH NATIONAL AND LOCAL ELECTRICAL REGULATIONS.

THIS DRAWING AND SPECIFICATIONS HEREIN ARE THE PROPERTY OF SCHNEIDER ELECTRIC AND SHALL NOT BE COPIED, REPRODUCED OR USED IN WHOLE OR IN PART, AS THE BASIS FOR THE MANUFACTURE OR SALE OF ITEMS WITHOUT WRITTEN PERMISSION FROM SCHNEIDER ELECTRIC. THIS DRAWING IS BASED UPON LATEST AVAILABLE INFORMATION AND IS SUBJECT TO CHANGE WITHOUT NOTICE.



TITLE: SMART-UPS VI 20KVA WITH ONE MAINS SUPPLY ON THE MBP INPUT: 3x400/230V DUAL FEED OUTPUT: 3x400/230V 4 MODULE CAPACITY SYSTEM ONE LINE DIAGRAM

DWG NO: SUVTP20KH2C4M1-SD
DRAWN: BALAMURUGAN 09-FEB-10
ENGINEER: B.H.NIELSEN 09-FEB-10
APPROVED: CLARSEN 09-FEB-10

REV. 1
ANGLE PROJECTION
N.A.