

1. DATUM LOCATIONS:
 -A- VERTICAL CENTERLINE OF LEFT
 GUIDE RAIL WHEEL GROOVE.

-B- BOTTOM EDGE OF GUIDE RAIL
 WHEEL GROOVE.

CATALOG NUMBERS

VT CELL, 2 CONTACT SC7-VI2
 VT CELL, 3 CONTACT SC7-VI3

(SHOWN)

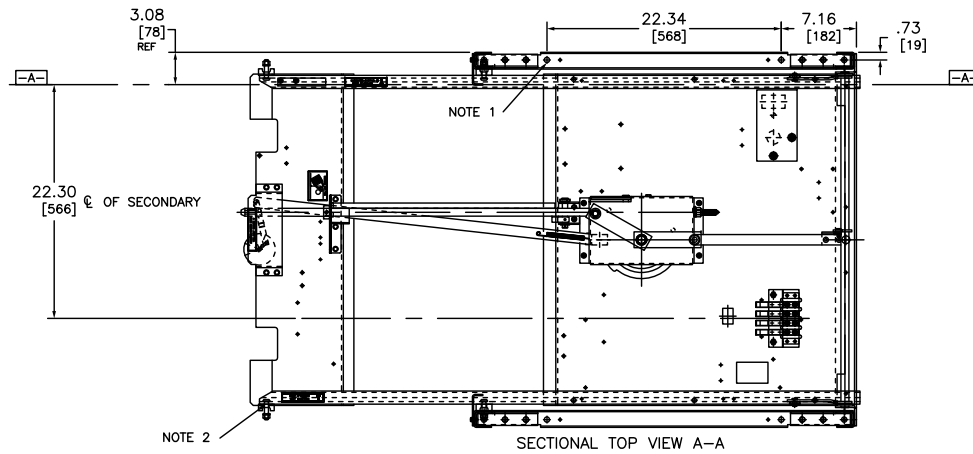

NOTES:

- (4) .500/[13] DIA. HOLES (2 EACH SIDE) PROVIDED IN FLOOR ANGLES TO BE USED AS PROVISIONS FOR BOLTING OR WELDING OF OEM FRAME TO FOUNDATION.
- OEM TO PROVIDE SUPPORT AT THE FRONT OF THE LEFT AND RIGHT BREAKER RAILS. A .406/[10] DIA. HOLE IS PROVIDED IN THE SIDE RAILS FOR THE PURPOSE.
- (8) 3/8-16 THREADED INSERTS ARE PROVIDED ON EACH SIDE OF THE OEM FRAME TO ALLOW OEM MEANS FOR BOLTING ON SIDE SHEETS OR OTHER STRUCTURES.
- (4) .500/[13] DIA. HOLES ARE PROVIDED IN REAR OF FRAME TO ALLOW OEM A MEANS OF BOLTING ON BUS COMPARTMENTS OR OTHER STRUCTURES. HOLES ARE LOCATED AT 7.00/[178] AND 34.50/[876].
- EXISTING HARDWARE FOR BOLTING BELL HOUSING IN PLACE IS LOCATED AT ELEVATIONS 3.00/[76], 20.75/[527] AND 38.50/[978]. OEM TO PROVIDE (6) .500/[13] DIA. CLEARANCE HOLES IN ANY STRUCTURE ATTACHING TO THE REAR OF THE FRAME.
- REFER TO DRAWING 46027-792 FOR TOP LEVEL ASSEMBLY. THIS DRAWING IS FOR ASSEMBLY PURPOSES AND IS NOT INTENDED FOR CUSTOMER DISTRIBUTION.
- 1/2-13 x 1.00/[25] DEEP TAPPED HOLE.
- DISCHARGE CHAIN FOR VT.

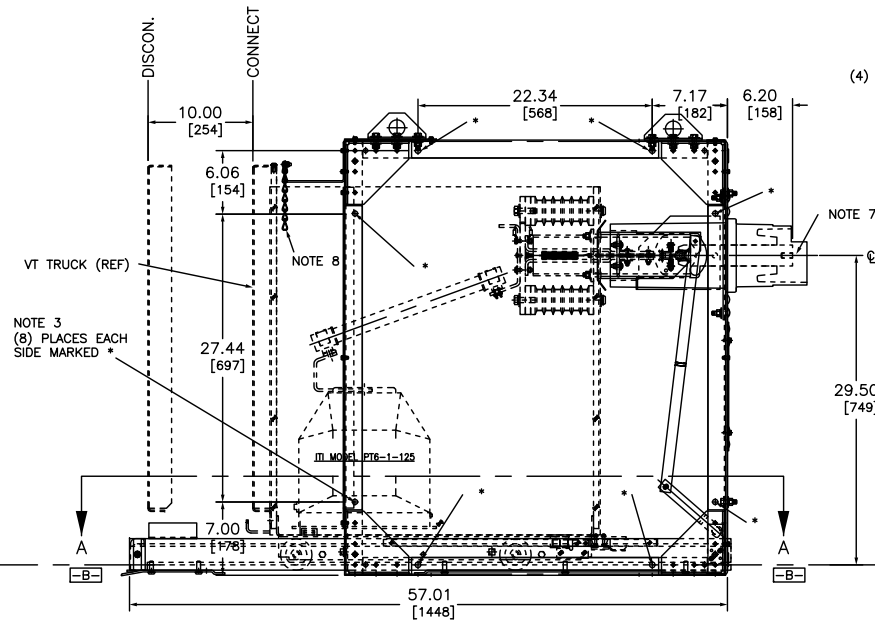
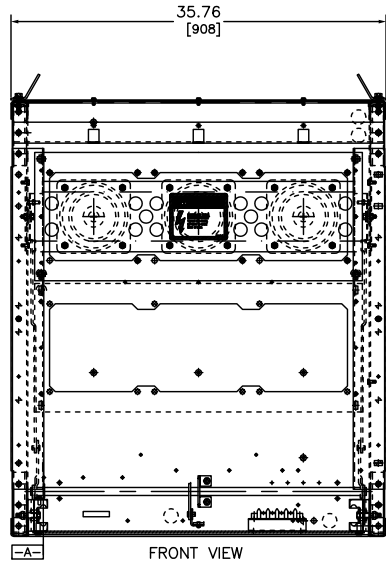

(4) LIFTING ANGLES

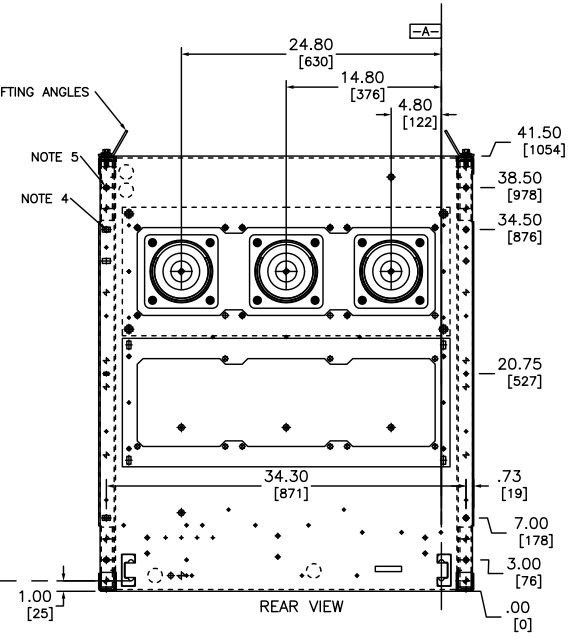

OEM
 ONE HIGH CRADLE
 LOWER AUX-VT



DWG# 46027-848
 NO.