

TOP VIEW
CONDUIT AREAS

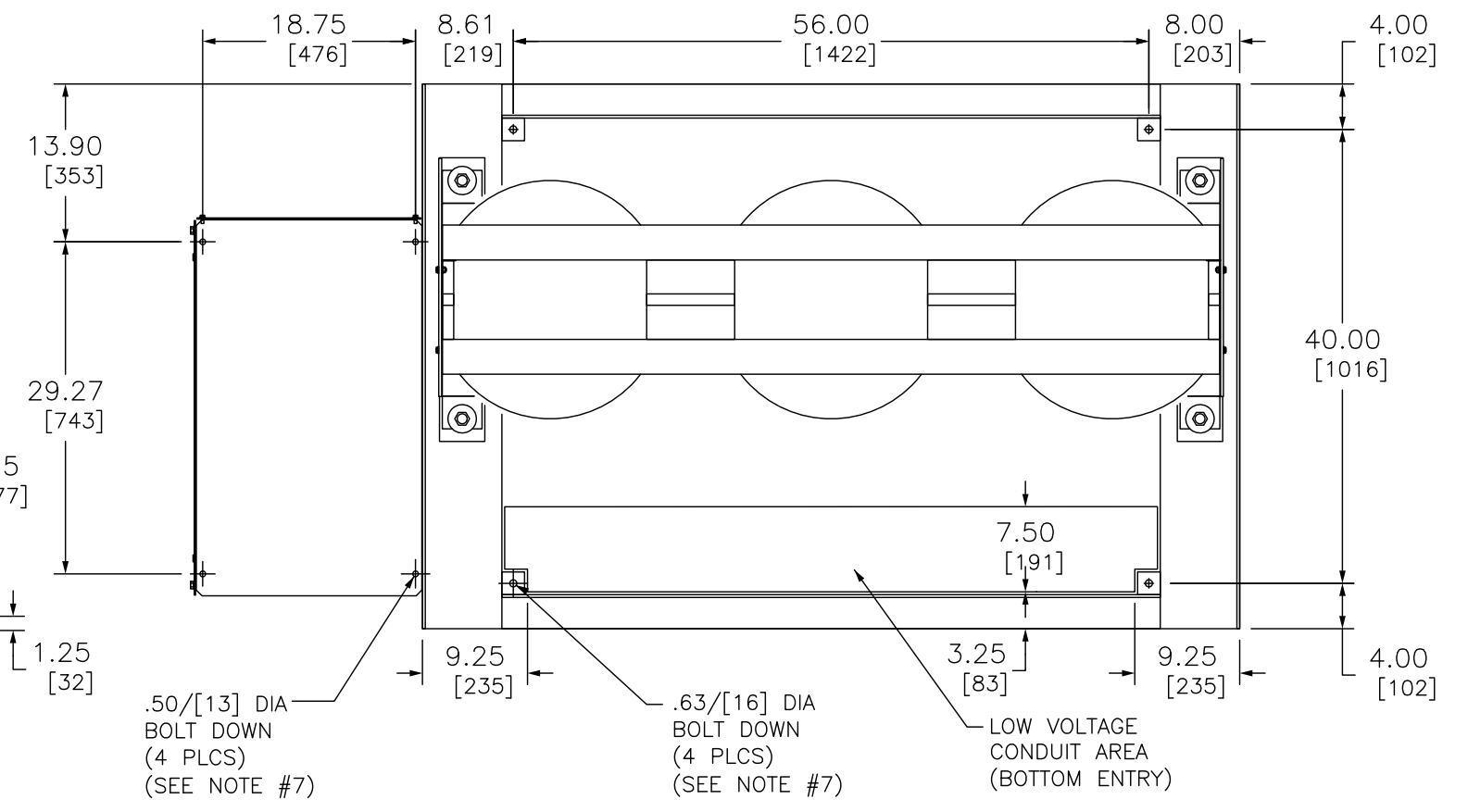

PLAN VIEW

MODEL 3 / HVLcc, (TOP ENTRY)

DUAL DIMENSIONS: INCHES
MILLIMETERS

MODEL 3/HVLcc OUTLINE DRAWING
(TOP ENTRY)



DWG# 44045-840-2000-72-001-01-2
NO.