

The Future of the electric power grid  
Protection and Control challenges of today and tomorrow

28/04/2017

**Presentation of the European project MIGRATE**

by Henri Grasset, Schneider Electric, France – [henri.grasset@schneider-electric.com](mailto:henri.grasset@schneider-electric.com)

Popov M. / Zargar B. / Chavez J., TU Delft, Netherlands,

Martínez E. / Borroy S., CIRCE, Spain,

Terzija V. / Azizi S. / Sun M., UoM, UK,

López S. / Pindado L. / Andrino R. / López D., REE, Spain,

Guibout C., RTE, France,

Kilter J. / Reinson A., ELERING, Estonia.

**Summary**

By 2020, several areas of the HVAC Pan-European transmission system will be operated with extremely high penetrations of Power Electronics (PE) interfaced generators, thus becoming the only generating units for some periods of the day or of the year due to renewable (wind, solar) electricity.

This will result in

1. Growing dynamic stability issues for the power system (possibly a new major barrier against future renewable penetration),
2. The necessity to upgrade existing protection schemes and
3. Measures to mitigate the resulting degradation of power quality due to harmonics propagation.

European TSOs from Estonia, Finland, France, Germany, Iceland, Ireland, Italy, Netherlands, Slovenia, Spain and UK have joined to address such challenges with a manufacturer (Schneider Electric) and universities/research centres. They will propose innovative solutions to progressively adjust the HVAC system operations.

Firstly, a replicable methodology is being developed for appraising the distance of any EU 28 control zone to instability due to PE proliferation and for monitoring it in real time, along with a portfolio of incremental improvements of existing technologies (the tuning of controllers, a pilot test of wide-area control techniques and the upgrading of protection devices with impacts on the present grid codes).

Next, innovative power system control laws are being designed to cope with the lack of synchronous machines. Numerical simulations and laboratory tests will deliver promising control solutions together with recommendations for new PE grid connection rules and the development of a novel protection technology and mitigation of the foreseen power quality disturbances. Technology and economic impacts of such innovations are being quantified together with barriers to be overcome in order to recommend future deployment scenarios. Dissemination activities support the deployment schemes of the project outputs based on knowledge sharing among targeted stakeholders at EC level.

## Introduction

During the first of the 4 years of MIGRATE project, Working Package 4 (WP4) developed models of Power Electronic (PE) devices which will be included in the benchmark grid that will be employed during the following years. The purpose of this benchmark grid is to create a testing platform for the study of the effective impact of these devices into the ability of present protection practices to properly operate during system disturbances. After this first stage, WP4 will have to evaluate or develop new protection strategies in order to overcome the constraints detected during this stage. At a final stage the aim is to give some guidelines about best protection practices for scenarios with high PE penetration.

Fault currents in networks supplied with Power Electronic (PE) converters may be limited in amplitude and its evolution will differ from that of conventional synchronous generators. Present protection practices have been developed for a system where synchronous generators are dominant. The behavior of this system is well known and documented in literature, standards and publications. In future, with the increasing penetration of PE, some of the traditional concepts and philosophies used by protection engineers for detecting and isolating faults (directionality, faulted phases, auto reclosing, etc.) may need some improvements in order to cope with scenarios with large penetrations of PE. Factors like the amplitude and phase of the currents injected or the speed of response, mainly related to converters control algorithms, may have some influence in traditional protection schemes, so predicting and minimizing potential impacts on the system security is crucial.

In order to assess these possible impacts, WP4 developed detailed Real Time Digital Simulator (RTDS) models with different control strategies, allowing the analysis of the influence that different variables associated with the algorithms implemented in the controls have in traditional protection schemes. Once this analysis is made, and possible constraints are detected, WP4 will evaluate possible solutions to overcome them.

### 1. 2016 task

The studies carried out in the WP will rely on Hardware in the Loop (HiL) simulations with RTDS.

To perform these simulations, generic PE devices models have been developed and included in a RTDS power system model. In the RTDS model, analogue and digital signals (currents, voltages, breaker positions, etc.) can be extracted from the simulations and sent to actual protection devices directly and through amplifiers. The actual protection devices behavior will be fed in the RTDS simulation that will automatically carry out the necessary actions to reflect the operation of the relay (opening breakers, closing those, send signals...) and recalculate in real time all the power system magnitudes.

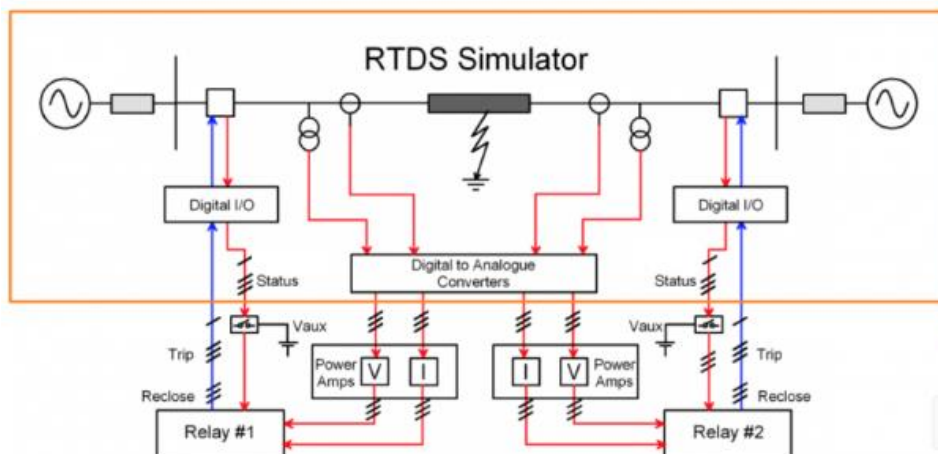

PE control strategies may differ from one manufacturer to another, and these control strategies are not usually available or sometimes are restricted due to intellectual property rights. Taking this into account, generic PE device models have been developed in order to detect general possible constraints of the integration of these devices and not only related with one manufacturer. For this reason, the models have been developed trying to offer flexibility for the user in order to assess the influence of different parameters in the behavior of present protection devices.

### Benchmark grid model

The benchmark model that is being used in this WP for studying different scenarios consists of a point-to-point terminal HVDC link that is connected to wind park, solar panels and conventional generation from different sides as well as it is connected to an infinite grid. The typical network is chosen in a way to look like benchmark model of the IEEE relaying committee upgraded with renewable sources and HVDC links. The proposed benchmark model is shown in Figure.

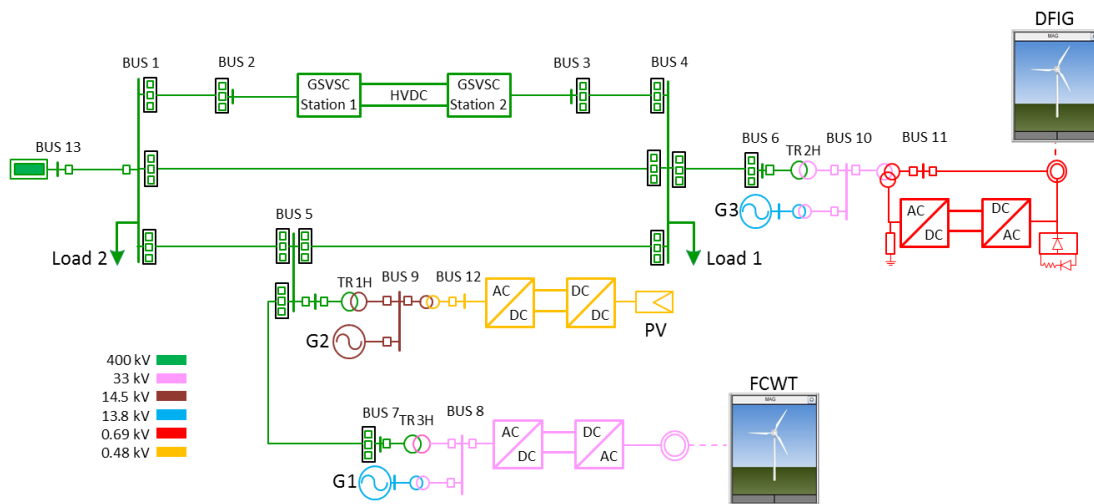

The crucial components that required particular attention and modeling efforts were:

- Model of a Doubly Fed Induction Generator (DFIG),
- Model of a full converter (FCWT) Permanent Magnet Synchronous Generator (PMSG),
- Two level VSC converter for the HVDC lines,
- Solar panel model connected to the system through a full converter,
- Conventional synchronous generator.

### Parametric Sensitivity for the DFIG model control loops

The FRT process of the DFIG affects not only the response of the wind turbine itself but moreover the fault current that the DFIG injects or absorbs from the grid. The sensitivities of the parameter that could affect the protection system would be the size of the crowbar if such an FRT scheme is followed. Also the control strategy followed when it is ignited as well as the control parameters related to the chopper if such an FRT strategy is followed.

### Parametric Sensitivity for the Type 4 wind turbine and PV generator

The reactive current boosting gain  $k$  ( $k$ -factor) affects the injection of the fault current to the grid for symmetrical faults. The overcurrent capability of the grid side converter of the type 4 wind turbine. Normally this is 1.1-1.5 in the wind turbine rating and it affects together with the gain  $k$  the fault magnitude of the fault current injection. For unbalanced two phase faults, the control loops associated with the negative sequence current control of the wind turbine could affect the unbalanced fault behavior of the AC



Note: Overcurrent will not be performed since it is well-known that the current limitation performed by the power electronic converters during fault will affect significantly the tripping by 50/51-50N/51N protection functions

In order to create different scenarios, two main settings for the infinite grid will be considered (strong/weak), in each of this setting three combinations of synchronous and PE generation are being tested.

After the initial tests, the results have been assessed and further cases are being applied. In this second stage, other parameters as negative sequence current injection, different converter settings and fault resistances have been taken into account to verify their possible impact in the performance of the protection functions.

Regarding the auto reclosing function (79), its performance has been assessed during the previous tests as well. Different Fault Type Identification Selection Logic will be then checked in order to discard possible maloperation.

### **Possible bottlenecks that may cause protection maloperation.**

In general, fault current levels in converter-based networks are limited by the converters. For full converter network, the fault current is quickly damped and limited to multiple of the nominal current (1.1-1.5). For a DFIG, the fault current may reach a peak value of even 4 pu, however, a time constant that defines fault current decay and the DC offset may be a bit longer than that of the full converter. In this project, as it has been mentioned, we have been dealing with DFIG, full converter PMSG, PV generator and HVDC links.

Since majority of faults are temporary, grid code defines a Fault Ride Through (FRT) characteristic which may differ for different countries. As it has been mentioned, these characteristics have been implemented in the models, taking into account present grid codes.

Crowbar resistances have been included in the rotor circuit in order to accomplish the FRT characteristics defined. During three-phase faults DFIG experiences high currents. In order to protect the rotor, the crowbar is activated and decreases the current significantly.

In general, high-impedance faults are difficult to detect because they may result to highly unpredictable fault values.

Fault location is also a parameter that may influence the protection operation. Normally for faults that are very close to the bus bar where the relay is located, the measured impedance by the relay maybe low because of the low value of the measured voltage.

### **Conclusions**

The results will be published next year.

To be continued. Stay tuned on <https://www.h2020-migrate.eu/>

### **List of abbreviations**

DFIG:	Doubly Fed Induction Generator	FC:	Full Converter
FCWT:	Full Converter Wind Turbine	FRT:	Fault Ride Through
GSVSC:	Grid-Side VSC	GSCC:	Grid Side Converter Control
HVDC:	High Voltage Direct Current	LVRT:	Low Voltage Ride Through
MPPT:	Maximum Power Point Tracking	PCC:	Point of Common Coupling
PE:	Power Electronic	PV:	Photo Voltaic
SG:	Synchronous Generators	VSC:	Voltage Source Converter

## Annex: Grid code requirements used

Low-voltage ride through (LVRT) refers to the capability of PE-based components to stay connected in short periods after a fault inception in the grid. According to the LVRT capability diagrams defined by TSOs, PE based components should stay connected to the grid in the case of voltage dips. The LVRT diagrams are introduced by TSOs for the PE based generation units and HVDC link. These profiles represent the lower limit of the positive sequence voltage (phase-to-phase voltage) at the PCC of the PE-based unit during a fault, as a function of time before, during and after the fault.

The PE based generating units should stay connected to the grid and continue stable operation for voltages above the specified voltage limit. However, the HVDC-link system is allowed to block when voltages at the PCC drops below a specific value (specified by TSOs). In the case of blocking condition, the system is connected to the network while there is no active and reactive power contribution for a period of time that will be as short as technically feasible and which shall be agreed between the relevant TSOs and the HVDC system owner.

LVRT profile applied to PE generators and HVDC Systems:

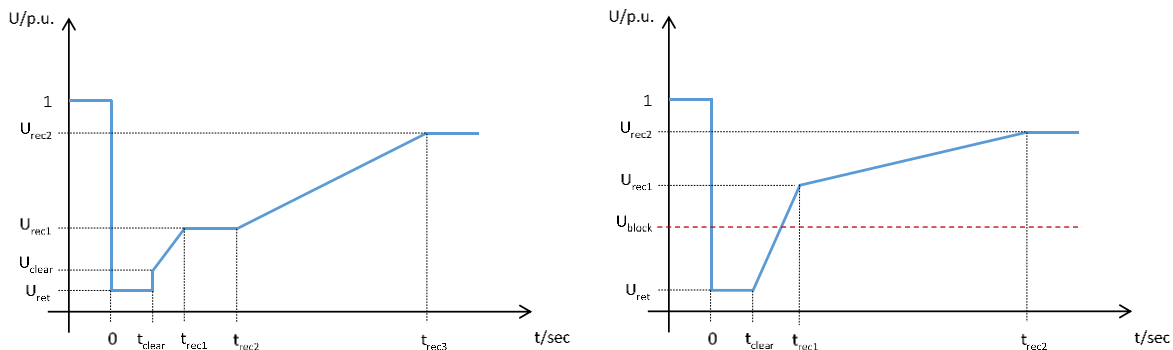

LVRT parameters for PE generators and HVDC:

Voltage parameters (pu)		Time parameters (seconds)	
<b>U<sub>ret</sub></b>	0	<b>t<sub>clear</sub></b>	0.14 – 0.15/0.25
<b>U<sub>clear</sub></b>	U <sub>ret</sub>	<b>t<sub>rec1</sub></b>	t <sub>clear</sub>
<b>U<sub>rec1</sub></b>	U <sub>clear</sub>	<b>t<sub>rec2</sub></b>	t <sub>rec1</sub>
<b>U<sub>rec2</sub></b>	0.85	<b>t<sub>rec3</sub></b>	1.5 – 3.0

Voltage parameters (pu)		Time parameters (seconds)	
<b>U<sub>ret</sub></b>	0.00 – 0.30	<b>t<sub>clear</sub></b>	0.14 – 0.25
<b>U<sub>rec1</sub></b>	0.25 – 0.85	<b>t<sub>rec1</sub></b>	1.5 – 2.5
<b>U<sub>rec2</sub></b>	0.85 – 0.9	<b>t<sub>rec2</sub></b>	t <sub>rec1</sub> – 10.0

In addition to this, the reactive power supply is a requirement during the voltage dips. The corresponding voltage control characteristic is shown in figure. Accordingly, PE based components have to inject at least 1.0 p.u. reactive current when the voltage drops below 50%. A dead-band of 10% is considered to avoid undesirable control actions.

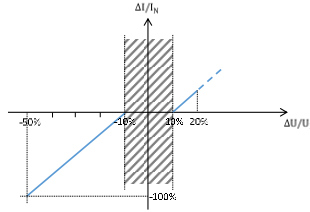

## Acknowledgement



This project has received funding from the European Union's Horizon 2020 research and innovation program under grant agreement No 691800.

Website: <https://www.h2020-migrate.eu/about.html>

## Keywords

European Project, MIGRATE, Power Electronics, 2020.

## About the presenter

Henri Grasset is an Automation Intelligent Electronic Device Expert at Schneider Energy Division. He holds an engineering degree from the Ecole Centrale de Nantes in France. He has worked in the Protection and Control domain since 1999.