

**Model 871A**  
**pH and ORP Sensors and Accessories**



*The Foxboro<sup>®</sup> brand 871A Electrochemical Sensors, when used with 871A Accessories, are suitable for many process pH and ORP measurement applications. As symbolized by the “CE” marking, these Sensors conform to all applicable European Union directives.*

**INTRODUCTION**

These sensors are used with Foxboro 870ITPH Intelligent Transmitters, 875PH Intelligent Analyzers, 870PH Analog Transmitters, and 873PH and 873DPX Electrochemical Analyzers.

Measurement of pH by the 871A Sensor is accomplished by immersing a flat glass electrode, with a double-junction, gel-filled reference electrode, into a process solution. The glass electrode produces an electric potential proportional to the hydrogen ion activity. The reference electrode completes the circuit and provides a stable reference for the glass electrode.

These two electrodes constitute an electrolytic cell having a millivolt output that is proportional to the pH of the solution.

ORP is related to the logarithm of the ratio of oxidation activity to reduction activity, just as pH is related to the logarithm of the hydrogen ion activity. A solution that contains an excess of oxidizing agent has a positive ORP, while one containing an excess of reducing agent has a negative ORP. Typical ORP applications include treatment of chromate and cyanide wastes produced by plating, chemical, and metal treatment plants. ORP monitoring enables industry to determine reaction end points and to meet today's stringent environmental requirements.

## **BROAD APPLICABILITY**

This innovative pH sensor assembly is suitable for many industrial pH applications. Its body is PVDF (polyvinylidene fluoride), a material which provides excellent resistance to chemicals. The flat glass (for pH), and platinum or gold (for ORP) measuring electrodes, in conjunction with the double-junction reference electrode, provide excellent performance within the specified operating range.

## **FLAT GLASS RUGGEDIZED ELECTRODE**

The 871A uses the Foxboro flat glass pH electrode. This electrode provides long life because of its rugged construction. In addition, its flat smooth surface resists coating and has a self-cleaning action in a flow stream.

## **INTEGRAL AUTOMATIC TEMPERATURE COMPENSATION**

Automatic temperature compensation (ATC), utilizing a platinum resistance temperature detector (RTD), is a built-in feature in the 871A Sensor.

## **SENSOR DIAGNOSTICS**

When used with the Foxboro 870ITPH Intelligent Transmitter or 875PH Intelligent Analyzer, the intelligent configurations of the sensor (Model Code Signal Conditioning Codes -3 and -4) provide diagnostic information. Sensor health checks will reveal the following faults:

- ▶ Broken glass electrode
- ▶ Aging glass electrode
- ▶ Liquid leakage into sensor body
- ▶ Failure of high impedance preamplifier in sensor (Signal Conditioning Code -4 only)
- ▶ Failure of temperature compensation element
- ▶ Excessive coating of the reference electrode, or sensor not in contact with process water.

## **SERVICE INTEGRITY**

A prime concern in the measurement of pH is the integrity of the electrode system. Valuable time is often consumed in the routine maintenance of measuring and reference electrodes. It is often found that an electrode station is faulty after initial service, thereby requiring additional material and labor to achieve satisfactory pH measurements. The 871A Sensor, with its sealed electrode design, eliminates this problem. The sensor is factory-tested to ensure proper performance upon installation.

## **NO METALLIC PARTS**

The 871A has no metallic wetted parts, other than the gold or platinum wire tip in the ORP version. The PVDF body electrode assembly, ceramic junction, and EPR (Ethylene Propylene Rubber) O-rings are the only process-wetted parts.

A solution ground, required for accurate pH measurement, is provided by the use of conductive PVDF. This feature negates the need for a metallic pin in contact with the process solution, which could be attacked by aggressive chemicals.

## **SIGNAL CONDITIONING**

The sensor assembly is available in either of two configurations. The more popular configuration includes an integral preamplifier that converts the high impedance millivolt sensor signal to a low impedance millivolt signal. This low impedance signal is then transmitted to the receiving device without a loss in signal. The sensor is also available without an integral preamplifier. This sensor can be used with any pH meter that accepts a high impedance signal, including the Foxboro 873PH, 873DPX and 875PH Analyzers, and 870ITPH Transmitters.

**MANY PROCESS MOUNTINGS**

The 871A Sensor can be mounted to the process in a variety of ways. The sensor has a 1-inch external NPT connection on both the electrode and cable ends. Mounting into a process line is achieved by direct insertion using the 1-inch NPT connection, or by the use of a variety of accessories which adapt this connection to other standard pipe sizes. In-situ mounting into weirs, flumes, ponds, tanks, or other open vessels is achieved by coupling the 1-inch NPT connection at the cable end of the sensor to a section of 1-inch pipe. In this way, the sensor may be lowered (and held) into a body of water. Wrench flats

are provided on the sensor body for easy tightening when installing the sensor. Refer to the “Accessories” and “Dimensions–Nominal” sections of this document for further information.

**INTRINSICALLY SAFE AND NONINCENDIVE DESIGN**

The 871A Sensors have been designed for use in intrinsically safe and hazardous area locations when used with the Foxboro Transmitters and Analyzers listed in Table 1.

**Table 1. Transmitters and Analyzers used with 871A Sensors**

PSS Number	Transmitter and Analyzer Model and Description
PSS 6-1A1 E	Model 875PH Intelligent Electrochemical Analyzer
PSS 6-1B1 B	Model 870ITPH Intelligent Electrochemical Transmitter
PSS 6-1C1 A	Model 870PH Analog Output Transmitter
PSS 6-1C1 E	Model 873PH Electrochemical Analyzer Model 873DPX Electrochemical Analyzer

**OPERATING CONDITIONS**

Influence	Reference Operating Conditions	Normal Operating Condition Limits
Process Temperature	25 ±3°C (77 ±5°F)	Refer to Figure 1
Process Pressure	0 kPa gauge (0 psig)	Refer to Figure 1
Mounting Position	Vertical (with Electrode End Down)	Vertical up to ±90° from Vertical (with Electrode End Downward)

### SENSOR PERFORMANCE SPECIFICATIONS

*(Under Reference Operating Conditions unless otherwise specified)  
(Refer to PSSs listed in Table 1 for System Performance Specifications)*Sensitivity

#### Sensitivity

##### pH MEASUREMENT

±0.02 pH (±1.5 mV)

#### Repeatability

##### pH MEASUREMENT

±0.05 pH (±3 mV)

### FUNCTIONAL SPECIFICATIONS

#### Measuring Electrode

##### pH MEASUREMENT

Flat glass

##### ORP MEASUREMENT

Platinum or gold, as specified

#### pH Measurement Range

2 to 12 pH for optimum accuracy (see NOTE)

##### NOTE

Range above represents optimum accuracy.  
Sensor can be used with Transmitters and  
Analyzers that are ranged from 0 to 14 pH.

#### ORP Measurement Range

±2000 mV

#### Reference Electrode

Ceramic double junction with KCl, nonflowing, gelled  
electrolyte, Ag/AgCl Halfcell.

#### Sensor/Analyzer/Transmitter Compatibility

Refer to Table 2.

#### Automatic Temperature Compensation (ATC)

##### FOR STANDARD CONFIGURATION SENSORS

2-wire platinum RTD, 100Ω

##### FOR INTELLIGENT CONFIGURATION SENSORS

*871A-3 Version*

2-Wire platinum RTD, 1000 Ω

*871A-4 Version*

3-Wire platinum RTD, 1000 Ω

#### Process Pressure-Temperature Limits

The limits shown in Figure 1 are applicable to all  
sensors, accessories, and material selections.

Figure 1. Process Pressure-Temperature Limits

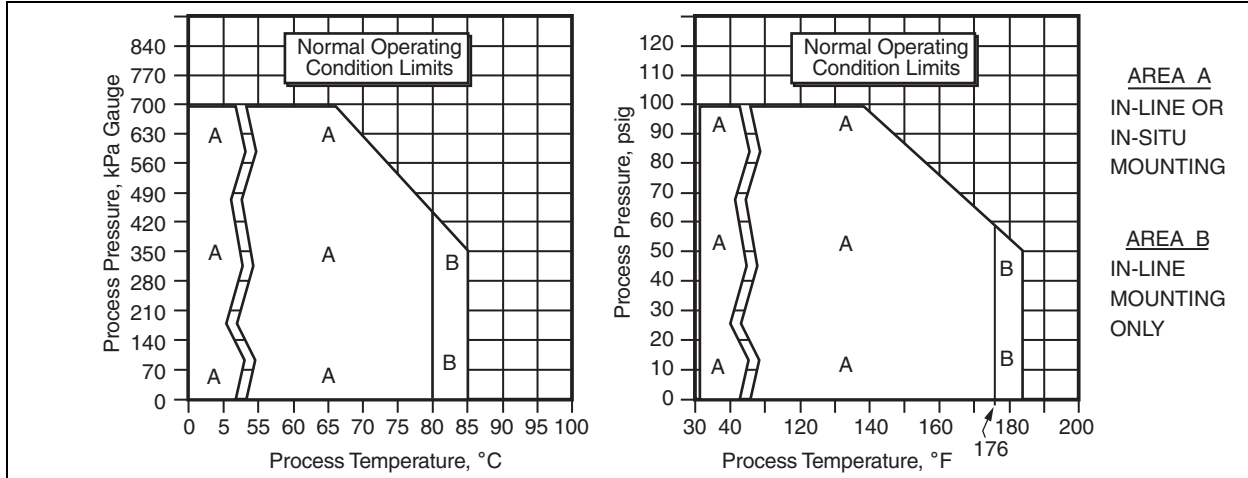

Table 2. Sensor/Analyzer/Transmitter Compatibility

Instrument	Sensor Signal Conditioning Code (a)			
	871A-1 (b)	871A-2 (c)	871A-3	871A-4
875PH Intelligent Analyzer (c)	15 m (50 ft) maximum	150 m (500 ft) maximum	15 m (50 ft) maximum	150 m (500 ft) maximum
873PH Analyzer	15 m (50 ft) maximum	150 m (500 ft) maximum	Not Compatible	Not Compatible
873DPX Analyzer	15 m (50 ft) maximum	150 m (500 ft) maximum	Not Compatible	Not Compatible
870ITPH Intelligent Transmitter (c)	15 m (50 ft) maximum	150 m (500 ft) maximum	15 m (50 ft) maximum	150 m (500 ft) maximum
870PH Transmitter (b)	15 m (50 ft) maximum	30 m (100 ft) maximum	Not Compatible	Not Compatible

(a) Maximum = Maximum allowable cable length between sensor and analyzer or transmitter.

(b) When 870PH instrument is used with an 871A-1 sensor, use of a remote preamplifier (Part No. PS290AA) is required.

(c) 875PH Analyzer and 870ITPH Transmitter when used with the 871A-2 Sensor are compatible but without the full diagnostic suite.

ELECTRICAL SAFETY SPECIFICATIONS

871A Sensor Certification

Testing Laboratory, Type of Protection, and Area Classification	Application Conditions	Electrical Safety Design Code
ATEX Type n energy limited for II 3GD EEx nL IIC, Zone 2	Connect to instrument per MI 611-208. Temperature Class T4 to T6. T110°C - T235°C.	CS-E/ANN
ATEX intrinsically safe for II 1GD EEx ia IIC, Zone 0	Connect to instrument per MI 611-208. Temperature Class T4 to T6. T110°C - T235°C.	CS-E/AAA
FM intrinsically safe for Class I, Div. 1, Groups A, B, C, and D; Class II, Div. 1, Groups E, F, and G; and Class III, Div. 1.	Connect to associated apparatus with compatible entity parameters per MI 611-206. Temperature Class T4 at 85°C maximum ambient.	CSS-FAA
FM nonincendive for Class I, Div. 2, Groups A, B, C, and D; suitable for Class II, Div. 2, Groups F and G; and Class III, Div. 2.	Connect to associated apparatus with compatible entity parameters per MI 611-206. Temperature Class T4 at 85°C maximum ambient.	CSS-FNN

871A Sensor/Transmitter/Analyzer Loop Approvals and Certifications (a)

Testing Laboratory, Type of Protection, and Area Classification	Transmitter/Analyzer Electrical Safety Design Code (b)
CSA certified for use in general purpose (ordinary) locations	870PH; CS-E/CG-A 873PH; Code CGZ 873DPX; Code CGZ
CSA certified for use in general purpose (ordinary) locations; and in Division 2 locations.	875PH; Code C
CSA certified for use in Division 2 locations.	870PH; Code CNZ 873DPX; Code CNZ 870ITPH; Code CNZ
CSA certified intrinsically safe in Division 1 locations.	870ITPH; Code CAA
FM approved for use in general purpose (ordinary) locations.	873PH; Code FGZ 873DPX; Code FGZ
FM approved for use in general purpose (ordinary) locations; and in Division 2 locations.	875PH; Code F
FM approved nonincendive, Division 2 locations.	873PH; Code FNZ 873DPX; Code FNZ 870ITPH; Code FNZ 870PH; CS-E/FN-A
FM approved intrinsically safe, Division 1 locations.	870ITPH; Code FAA 870PH; CS-E/FB-A
UL approved for use in general purpose (ordinary) locations.	875PH; Code U

(a) The 871 A sensor is loop-certified or approved for use with the transmitters/analyzers listed above. For further details, refer to the transmitter or analyzer PSS listed in Table 1.

(b) The Electrical Safety Design Code may be a certification specification (e.g., CS-E/CG-A) which is separate from the basic Transmitter/Analyzer Model Code; or it may be a part of the basic Transmitter/Analyzer Model Code (e.g., safety code CGZ, F, etc.). Refer to the applicable Transmitter/Analyzer PSS listed in Table 1 for further information.

## PHYSICAL SPECIFICATIONS

**Process-Wetted Parts Materials****BODY**

PVDF (polyvinylidene fluoride)

**MEASURING ELECTRODE**

*pH Measurement*

Flat Glass

*ORP Measurement*

Platinum or Gold, as specified.

**REFERENCE ELECTRODE**

Ceramic Junction

**O-RING**

EPR (Ethylene Propylene Rubber)

**Cable Length**

- ▶ Standard 3 m (10 ft) cable is integral with sensor assembly.
- ▶ Optional integral cable length to 15 m (50 ft) offered. Additional extension cable available to allow a maximum cabling distance between sensor and transmitter/analyzer per Figure 13 and Table 2. See ACCESSORIES section for extension cables, interconnecting junction boxes, and remote preamplifier.
- ▶ When sensor has no integral preamplifier, the limit between sensor and transmitter/analyzer is 15 m (50 ft). This cabling length can be extended to 150 m (500 ft) by using a remote preamplifier. Refer to ACCESSORIES section.

**Wire Terminations**

The sensor is offered with PVC-jacketed cable having electrical terminations as follows:

- ▶ Integral Sensor Cable 3 m (10 ft) long; terminated with crimped-on straight pin lugs. Optional cable lengths up to 15 m (50 ft) are offered.
- ▶ Integral Sensor Cable 3 m (10 ft) long; terminated in a connector plug; available for Sensor Model 871A-2 only. Optional cable lengths with a connector plug up to 15 m (50 ft) are also offered.

**Sensor Mounting**

1-in external NPT on both ends, with a 1.125-in wrench flat on body. For in-situ or in-line mounting, as required. See “Dimensions – Nominal” section.

**Immersion Depth**

76 mm (3 in) minimum

**Dimensions**

Refer to DIMENSIONS - NOMINAL section.

**Approximate Mass**

0.34 kg (0.75 lb)

ACCESSORIES

**Bushings (Figure 2)**

Bushings are used to mount sensors in a system that has process piping larger than the 1-in external NPT connection of the sensor. Bushings are offered with 1 1/4-in or 1 1/2-in external NPT connections, and are available in either 316 ss, PVDF, or CPVC. See Table 3 for bushing specifications

Figure 2. Bushing

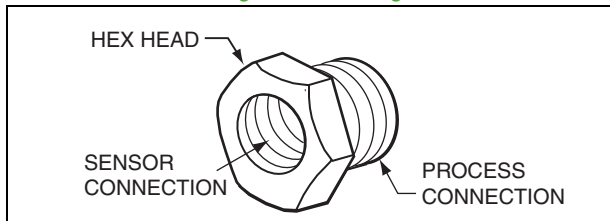

Table 3. Bushing Specifications (a)

Bushing Material	Sensor Connection	Process Connection	Part No.
316 ss	1 NPT	1 1/4 NPT 1 1/2 NPT	BS805TD BS805TF
PVDF	1 NPT	1 1/2 NPT	BS805TG
CPVC	1 NPT	1 1/4 NPT 1 1/2 NPT	BS805TE BS805TH

(a) See Figure 1 for pressure-temperature rating.

**Flow Chambers (Figure 3)**

Flow chambers are a convenient way of mounting sensors in a system where a sample is provided by a small diameter sample line. The inlet and outlet ports of the flow chamber are provided with either 1/4 NPT or 1/2 NPT internal threads, and connect to the system with user-supplied fittings. The flow chamber is offered in AISI Type 316 stainless steel (316 ss), PVDF, or CPVC (chlorinated polyvinyl chloride). Refer to Table 4 for flow chamber specifications.

Figure 3. Flow Chamber

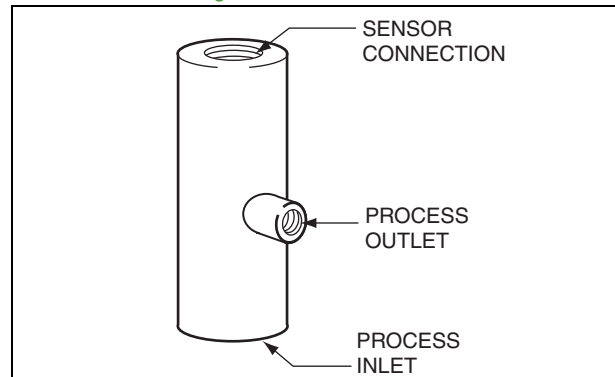

Table 4. Flow Chamber Specifications (a)

Flow Chamber Material	Sensor Connection	Process Connections	Part No.
316 ss	1 NPT 1 NPT	1/4 NPT 1/2 NPT	BS805SP BS805SS
PVDF	1 NPT 1 NPT	1/4 NPT 1/2 NPT	BS805SQ BS805ST
CPVC	1 NPT 1 NPT	1/4 NPT 1/2 NPT	BS805SR BS805SU

(a) See Figure 1 for pressure-temperature rating.



**Tee Assemblies (Figure 4)**

Tees are used for flow-through installations in a pipeline. The sensor and process connection ends are internally threaded for the 316 ss and PVDF materials, and have internal pipe socket weld connections for the CPVC material. Reducing bushings are used on the sensor end, and also process ends (as required) to accommodate the 1-inch NPT sensor and various process connection sizes. Refer to Table 5 for tee assembly specifications.

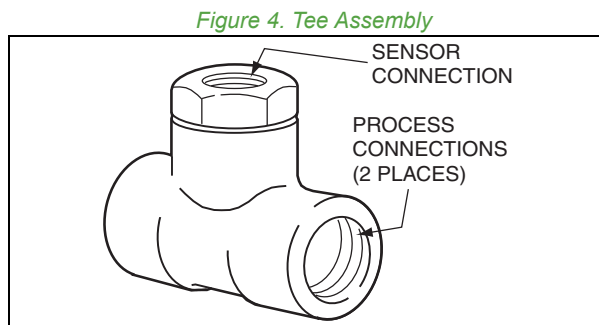

**Table 5. Tee Assembly Specifications (a)**

Tee Assembly Material	Sensor Conn. (b)	Process Connections (c)	Part No.
316 ss	1 NPT	1 NPT 1 1/4 NPT 1 1/2 NPT	BS805SV BS805SY BS805TA
PVDF	1 NPT	1 NPT 1 1/2 NPT	BS805SW BS805TB
CPVC	1 NPT	33 mm (1.3 in) (d) 41 mm (1.6 in) (d) 48 mm (1.9 in) (d)	BS805SX BS805SZ BS805TC

- (a) See Figure 1 for pressure-temperature rating.
- (b) Reducing bushing is used to accommodate a 1 NPT sensor connection.
- (c) Reducing bushings are used as required to accommodate the process connections listed in the table.
- (d) Pipe socket-weld.

**Electrode Protection Sleeve (Figure 5)**

The electrode protection sleeve protects the glass electrode from contacting the bottom or side of a tank. This PVDF sleeve is applicable to submersible applications, and is usable within the pressure-temperature limits shown in Figure 1. Specify Part Number BS805TJ.

*Figure 5. Electrode Protection Sleeve*

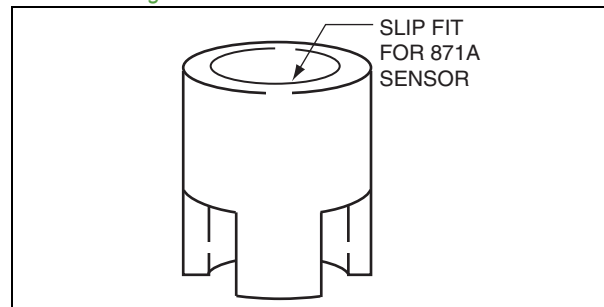

**Buffers**

Buffers are available as a solution, or in a salt packet. When provided in a salt packet, the buffer is mixed with 0.47 litres (16 fluid ounces) of distilled water to convert to a buffer solution. Refer to Table 6 below for part numbers for Buffer Solutions and Salt Packets.

**Table 6. Buffer Solutions and Salt Packets**

Buffer Type	Buffer Description	Part No.
Solution	4.00 pH, 0.47 L (16 fl oz)	Q0104KC
	7.00 pH, 0.47 L (16 fl oz)	Q0104KB
	10.00 pH, 0.47 L (16 fl oz)	Q0104KA
Salt Packet	4.00 pH (Note a)	1600100
	7.00 pH (Note a)	1600101
	10.00 pH (Note a)	1600102

- (a) Mix buffer packet with 0.47 L (16 fl. oz.) of distilled water to convert to solution form.

**Ball Valve Assemblies (Figure 6)**

Purgeable ball valve assemblies are offered. A ball valve assembly permits an 871A Sensor to be inserted and removed from a process stream or tank under rated temperature and pressure without draining the system or resorting to a bypass arrangement. The assembly consists of the ball valve unit and an insertion shaft assembly; both support a sensor in a stream. A standard flexible conduit (user provided) can be used for cable protection. Also see Table 7.

Figure 6. Purgeable Ball Valve Assembly

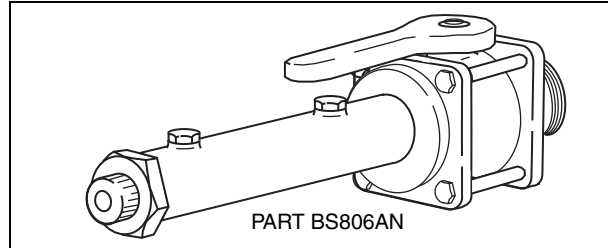

Table 7. Ball Valve Assembly Specifications

Materials of Process Wetted Parts (a)				Rated Pressure (b)		Max. Temp. (b) at Rated Pressure		Process Line Connection	Part Number
Process Connection and Housing	Ball Seat	Ball Valve	O-Ring						
316 ss	ptfe	Glass-Filled Polypropylene	EPR	1.0	145	20	70	1 1/2 NPT	BS806AN
				0.4	55	65	150		
				0.07	10	88	190		
Titanium	ptfe	Kynar	EPR	1.6	230	20	68	1 1/2 NPT	BS806EP
				1.0	145	60	140		
				0.35	50	140	284		

(a) Refer to Global Customer Support for other materials.

(b) Actual application rating may be reduced by sensor pressure/temperature rating. Refer to Figure 1.

**Junction Boxes - Surface Mounted (Figure 7)**

Three junction boxes are offered that provide the cabling interconnection between the sensor and transmitter or analyzer. They can be used with sensors having or not having an integral preamplifier. (Junction boxes are simply interconnection devices and do not have preamplifiers. Refer to Remote Preamplifier section that follows.) There is a generous amount of space within each junction box to accommodate the terminal blocks, and the sensor and transmitter/analyzer cable assembly terminations. These junction boxes have the dusttight and weatherproof rating of IP65 as defined by IEC 60529, and provide the NEMA ratings listed in Table 8. Refer to Figure 13.

**Table 8. Junction Box Part Numbers and Application**

Junction Box Part No.	Junction Box used with Sensors Listed Below	Sensor has Integral Preamp.	Junction Box NEMA Rating
BS813XN	871A-1, -3 (a)	NO	4X
0051052	871A-2 only (b)	YES	4
BS807BZ	871A-4 only (a)	YES	6

- (a) Extension cables can be provided. See Table 10.
- (b) Extension cables or patch cords can be provided. See Table 10.

*Figure 7. Junction Boxes and Part Numbers Shown with Covers Removed*

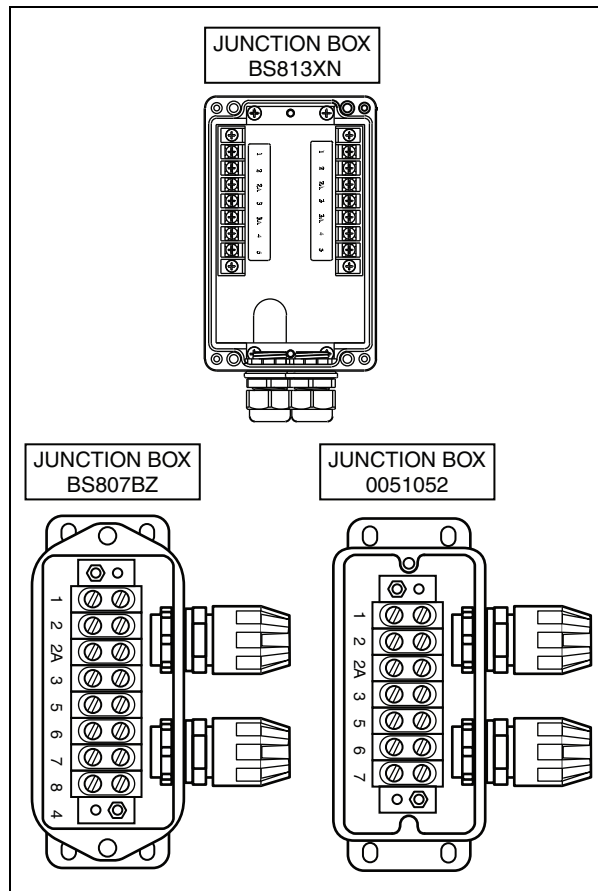

### Remote Preamplifier (Figure 8)

Certain installations require a sensor without an integral preamplifier, but still must connect to a transmitter or analyzer with a cabling distance more than 15 m (50 ft) away. In this situation, a junction box with a remote preamplifier is provided that interconnects the sensor and transmitter/analyzer with a total cable length up to 150 m (500 ft) maximum. The junction box enclosure has a NEMA 4X rating that provides weatherproof, dustproof, and corrosion resistant protection. See Table 9 and Figure 13.

**Table 9. Remote Preamplifier Part Number and Application**

Remote Preamplifier Part No.	Remote Preamplifier used with Sensors Listed Below	Enclosure Rating
BS811MR	871A-1, 871A-3 (a)	NEMA 4X

(a) Extension cables can be provided. See Table 10.

*Figure 8. Junction Box with Remote Preamplifier*

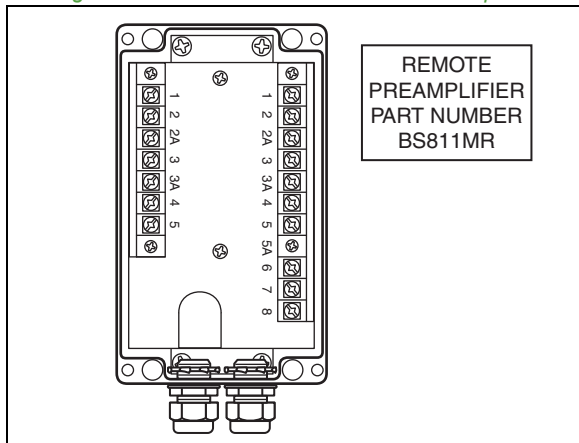

### Patch Cords (Figure 9)

Patch Cords provide connections between an 871A-2 sensor, with Optional Cable Selection Codes -5 or -7, and either a transmitter or analyzer. There is a connector socket on one end of the patch cord that mates with the 871A-2.-5 or 871A-2.-7 sensor that terminates in a connector plug. The patch cord has leads with straight pin lugs on the other end that connect to the transmitter or analyzer. They are offered in 15 m (50 ft) lengths, or lengths up to 150 m (500 ft). Refer to Table 10 for part numbers and temperature limits, and to Figure 13 for configuration and application.

*Figure 9. Patch Cord*

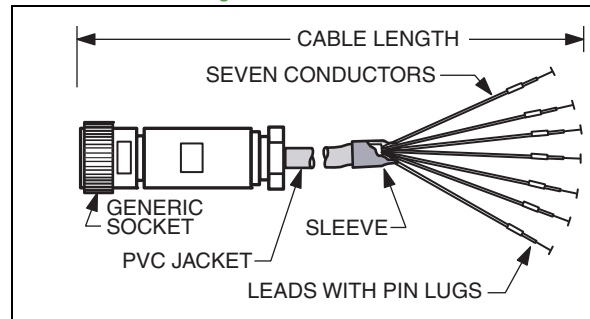

**Extension Cables (Figures 10 and 11)**

These multi-conductor PVC-jacketed extension cables provide intrasystem connections.

For sensors without an integral preamplifier, or for systems without a remote preamplifier, these extension cables are offered with straight pin lugs on both ends with cable lengths of 3, 6, 9, 12, or 15 m (10, 20, 30, 40, or 50 ft). Refer to Table 10, and Figure 13.

For sensors with an integral preamplifier, or for systems with a remote preamplifier, these extension cables are offered with straight pin lugs on both ends with a cable length specified by the user, but not exceeding 150 m (500 ft). Refer to Table 10 for part numbers and temperature limits, and to Figure 13 for configuration and application.

**Raw Underterminated Cable (Figure 12)**

Multi-conductor, PVC-jacketed, raw, unterminated cable is also offered for intrasystem connections for use with sensors with or without an integral preamplifier, or with or without a remote preamplifier. Raw Cable Part Number P0170UU is used when there is no preamplifier in the system, while Part Number P0170UV is used when there is a preamplifier in the system. These unterminated cables are offered in continuous lengths up to 300 m (1000 ft), on a per meter or per foot basis. Refer to Table 10 for part numbers and temperature limits.

Figure 10. Extension Cable Assemblies when No Preamplifier is used on the System

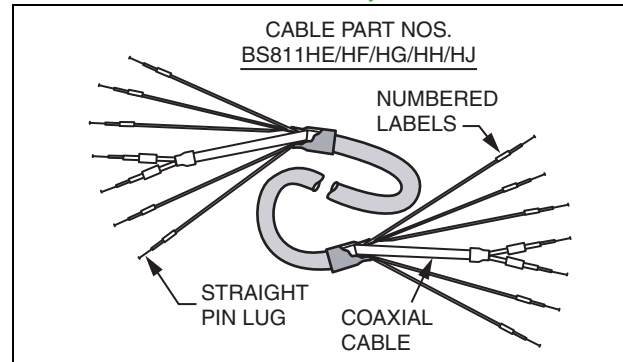

Figure 11. Extension Cable Assembly when a Preamplifier is used in the System

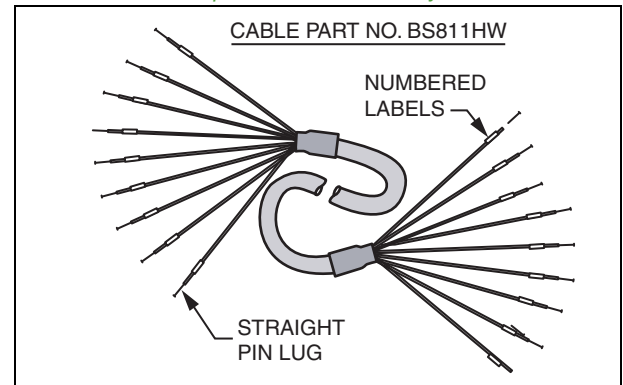
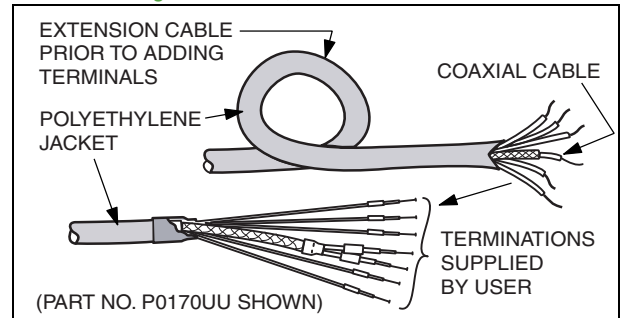

Figure 12. Raw, Unterminated Cable



**Accessories used for Intra System Cabling**

Figure 13 depicts the typical interconnections between a sensor and a transmitter or analyzer. Note that the interconnection topography varies depending on the sensor, junction box, remote amplifier, extension cable, or patch cord used. Also note that when the sensor has an integral preamplifier, or when a remote preamplifier is used, the cabling length can be up to, but not more than, 150 m (500 ft). When there is no preamplifier, the maximum cabling length allowed between sensor and transmitter or analyzer is 15 m (50 ft). Patch cords, extension cables, junction boxes, or a remote amplifier can be provided for the installation required by the user. Refer to Figure 13 for typical system installation topologies, and refer to Table 10 for patch cord and extension cable descriptions and part numbers.

**Electrode Cleaning System**

The Model ECS Electrode Cleaning system comprises a family of automatic in-line electrode cleaners used exclusively with many Foxboro pH and ORP sensors, including the 871A sensor. The continuous rotation of the cleaning element across the measuring element(s) minimizes or totally eliminates physical coatings that interfere with obtaining accurate measurements. The Model ECS is offered in various flow-through and submersible assembly configurations. Refer to PSS 6-1A2 C for configurations available, specifications, and ordering instructions.

Figure 13. System Installation Topologies using Intra System Cabling Accessories

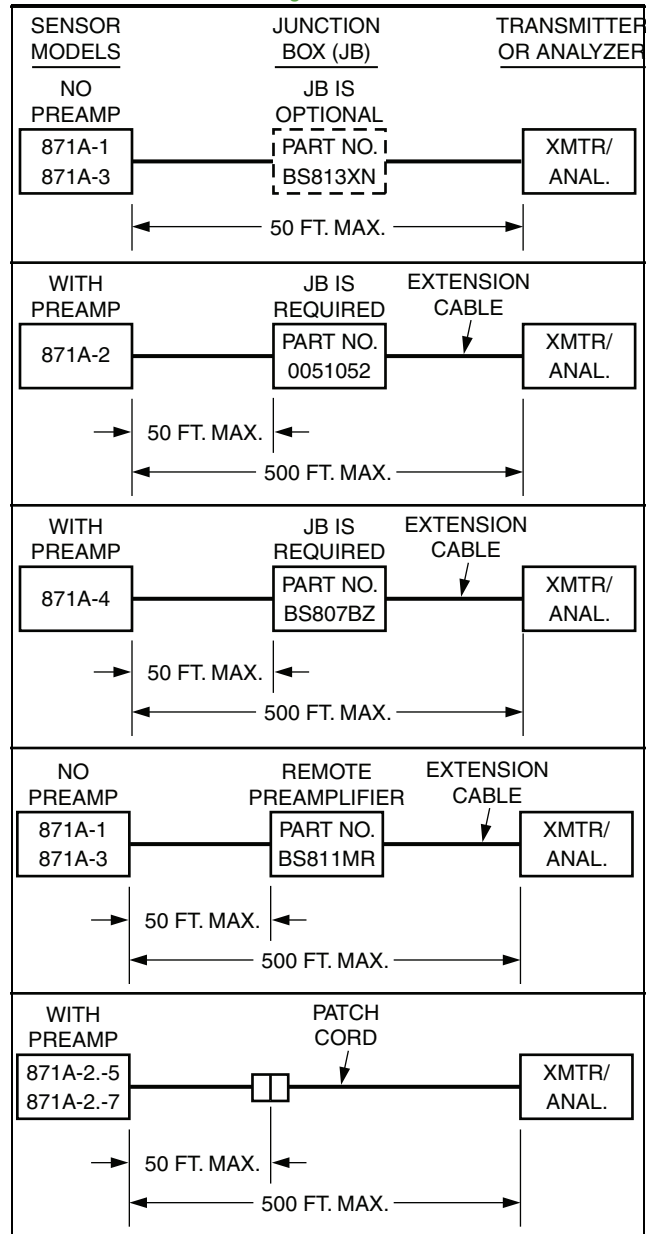

Table 10. Patch Cord, Extension Cable, and Raw Cable Part Numbers

Part Number (c)	Temperature Limit	Sensor Model	Cable Option Code(s)	Terminations	Length (a)
<b>Patch Cords used with Sensor having an Integral Preamplifier, and Cable Option Codes -5 and -7</b>					
BS811PV (BS806NV)	-30 to +85°C (-22 to +185°F)	871A-2	-5, -7	Connector Socket on one end; and straight pin lugs on other end	3 m (10 ft)
BS5811PW (BS806NW)		871A-2	-5, -7		to 150 m (500 ft) (b)
(a) Cable length tolerance is +1, -0 ft (+0.3, -0 m). (b) Nonstandard cable length per sales order up to 150 m (500 ft). Specify both part number and patch cord length desired. (c) Cable part number BS806NV has been replaced by part number BS811PV; and cable part number BS806NW has been replaced by part number BS811PW. The new cables BS811PV and BS811PW are backwards compatible with the older sensors.					
<b>Extension Cable used with Sensor without an Integral Preamplifier, and without a Remote Preamplifier</b>					
BS811HE	-20 to +85°C (-4 to +185°F)	871A-1, -3	-3	Straight Pin Lugs on Both Ends	3 m (10 ft)
BS811HF		871A-1, -3	-3		6 m (20 ft)
BS811HG		871A-1, -3	-3		9 m (30 ft)
BS811HH		871A-1, -3	-3		12 m (40 ft)
BS811HJ		871A-1, -3	-3		15 m (50 ft)
<b>Extension Cable used with Sensor having an Integral Preamplifier, or a System with a Remote Preamplifier (a)</b>					
BS811HW	-30 to +85°C (-22 to +185°F)	871A-2, -4 Note (b)		Straight Pin Lugs on Both Ends	to 150 m (500 ft) (c)
(a) Remote preamplifier part number is BS811MR. (b) Not for use with Sensor Models 871A-2.-5 or 871A-2.-7. These sensors require patch cords. (c) Specify extension cable length up to a maximum of 150 m (500 ft).					
<b>Raw Cable, Underterminated, for Users who wish to make their own Extension Cable</b>					
P0170UU (a)	-20 to +85°C (-4 to +185°F)	871A-1, -3	This raw, underterminated cable is ordered in lengths to 300 m (1000 ft), on a per meter or per foot basis.		up to 300m (up to 1000 ft)
P0170UV (b)	-30 to +85°C (-22 to +185°F)	871A-2, -4			
(a) Five conductor cable (1 coaxial plus 4 primary) with PVC jacketed shield. For use when there is no preamplifier in the system. (b) Eight conductor cable with an overall shield and drain wire, all PVC jacketed. For use with Remote Preamplifier Part Number BS811MR, or with a sensor having an integral preamplifier.					

MODEL CODE

<b>Description</b>	<u>Model</u>
pH and ORP Sensor	871A
<b>Signal Conditioning (a)</b>	
Standard Configuration, No Preamplifier	-1
Standard Configuration, Integral Preamplifier	-2
Intelligent Configuration, No Preamplifier	-3
Intelligent Configuration, Integral Preamplifier	-4
<b>Measuring Electrode and Material</b>	
pH, Flat Glass	F
ORP, Platinum	D
ORP, Gold	E
<b>Optional Integral Cable Selection</b>	
See Notes (b) and (c)	-1
Nonstandard Integral Cable Length to 15 m (50 ft); specify length (d) (c)	-3
Nonstandard Integral Cable Length to 15 m (50 ft), specify length; select with 871A-2 Sensor only Terminated in Connector Plug (e)	-5
Standard 3 m (10 ft) Integral Cable, select with 871A-2 Sensor only Terminated in Connector Plug (f)	-7
Examples: 871A-2F-7; 871A-3F-3 (40 ft required)	

- a. Refer to Table 2 for compatibility with transmitters and analyzers.
- b. The -1 option is no longer used to add No. 6 spade lugs (standard termination is now straight pin lugs), but the selection is still offered to users who have previously made, and still require, this selection. This selection is functionally equivalent to the previously supplied - 1 option which had No. 6 spade lugs.
- c. Optional Integral Cable Selections -1 and -3 may each be selected individually, or as a combination.
- d. Sensor assembly includes an integral 3 m (10 ft) integral cable with straight pin lugs.
- e. Optional Integral Cable Selections -5 and -7 require a patch cord to mate to transmitter/analyzer. See ACCESSORIES section.
- f. Not compatible with ball valve assembly mountings.



DIMENSIONS – NOMINAL

$\frac{\text{mm}}{\text{in}}$

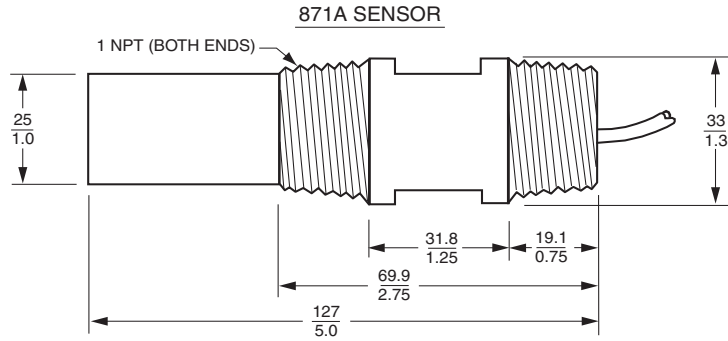

TEE ASSEMBLIES (INCLUDES REDUCING BUSHINGS)

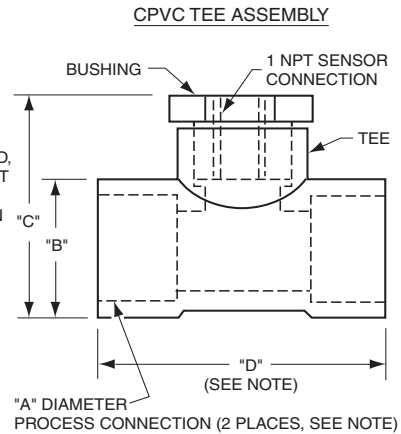
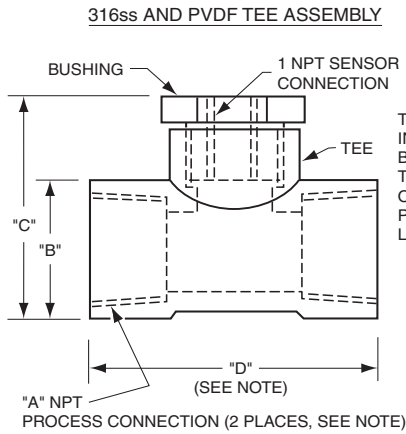

NOTE  
THE "D" DIMENSION INCLUDES REDUCING BUSHINGS, IF REQUIRED, TO PROVIDE THE "A" NPT OR "A" DIAMETER PROCESS CONNECTION LISTED IN THE TABLES.

316 ss and PVDF Tee Assemblies

Part Number	Material	Dimensions (a)			
		"A"	"B"	"C"	"D"
BS805SV	316 ss	1 NPT	$\frac{64}{2.5}$	$\frac{94}{3.7}$	$\frac{124}{4.9}$
BS805SW	PVDF	1 NPT	$\frac{64}{2.5}$	$\frac{89}{3.5}$	$\frac{147}{5.8}$
BS805SY	316 ss	1 1/4 NPT	$\frac{64}{2.5}$	$\frac{94}{3.7}$	$\frac{124}{4.9}$
BS805TA	316 ss	1 1/2 NPT	$\frac{64}{2.5}$	$\frac{94}{3.7}$	$\frac{99}{3.9}$
BS805TB	PVDF	1 1/2 NPT	$\frac{64}{2.5}$	$\frac{89}{3.5}$	$\frac{122}{4.8}$

(a) The "B", "C", and "D" dimensions listed are approximate.

CPVC Tee Assemblies

Part Number	Material	Dimensions (a)			
		"A"	"B"	"C"	"D"
BS805SX	CPVC	$\frac{33}{1.3}$	$\frac{64}{2.5}$	$\frac{102}{4.0}$	$\frac{193}{7.6}$
BS805SZ	CPVC	$\frac{41}{1.6}$	$\frac{64}{2.5}$	$\frac{102}{4.0}$	$\frac{137}{5.4}$
BS805TC	CPVC	$\frac{48}{1.9}$	$\frac{64}{2.5}$	$\frac{102}{4.0}$	$\frac{124}{4.9}$

(a) The "B", "C", and "D" dimensions listed are approximate.

**BUSHINGS**

**mm**  
**in**

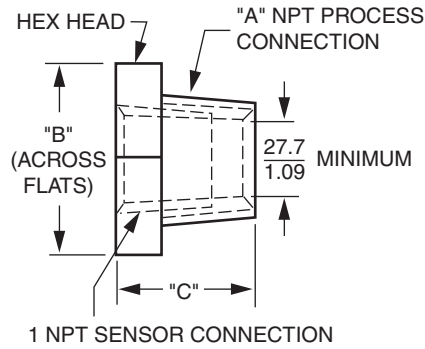

Part Number	Material	Dimension (a)		
		"A"	"B"	"C"
BS805TD	316 ss	1 1/4 NPT	$\frac{46}{1.8}$	$\frac{30}{1.2}$
BS805TE	CPVC	1 1/4 NPT	$\frac{41}{1.6}$	$\frac{36}{1.4}$
BS805TF	316 ss	1 1/2 NPT	$\frac{51}{2.0}$	$\frac{33}{1.3}$

**FLOW CHAMBERS**

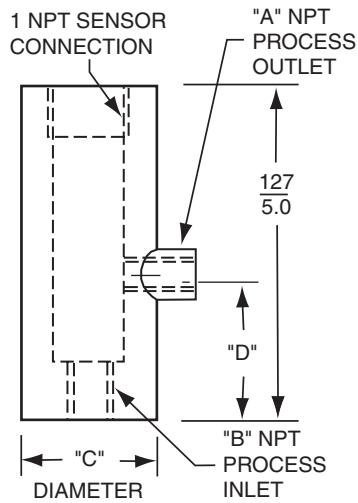

Part Number	Material	Dimensions (a)			
		"A"	"B"	"C"	"D"
BS805SP	316 ss	1/4 NPT	1/4 NPT	$\frac{44}{1.75}$	$\frac{44}{1.75}$
BS805SQ	PVDF	1/4 NPT	1/4 NPT	$\frac{51}{2.00}$	$\frac{56}{2.2}$
BS805SR	CPVC	1/4 NPT	1/4 NPT	$\frac{44}{1.75}$	$\frac{44}{1.75}$
BS805SS	316 ss	1/2 NPT	1/2 NPT	$\frac{44}{1.75}$	$\frac{44}{1.75}$
BS805ST	PVDF	1/2 NPT	1/2 NPT	$\frac{51}{2.00}$	$\frac{56}{2.2}$
BS805SU	CPVC	1/2 NPT	1/2 NPT	$\frac{44}{1.75}$	$\frac{44}{1.75}$

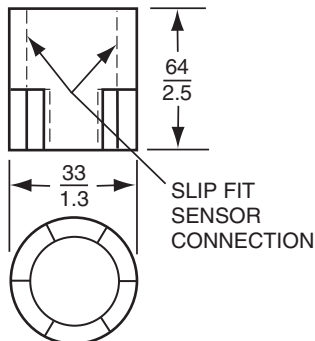

**ELECTRODE PROTECTION SLEEVE**  
**PART NUMBER BS805TJ**

NOTE  
ELECTRODE PROTECTION SLEEVE  
IS AVAILABLE IN PVDF MATERIAL  
ONLY.

$\frac{\text{mm}}{\text{in}}$

**BALL VALVE ASSEMBLY WITH 316 ss PROCESS CONNECTION AND PURGEABLE HOUSING  
PART NUMBER BS806AN**

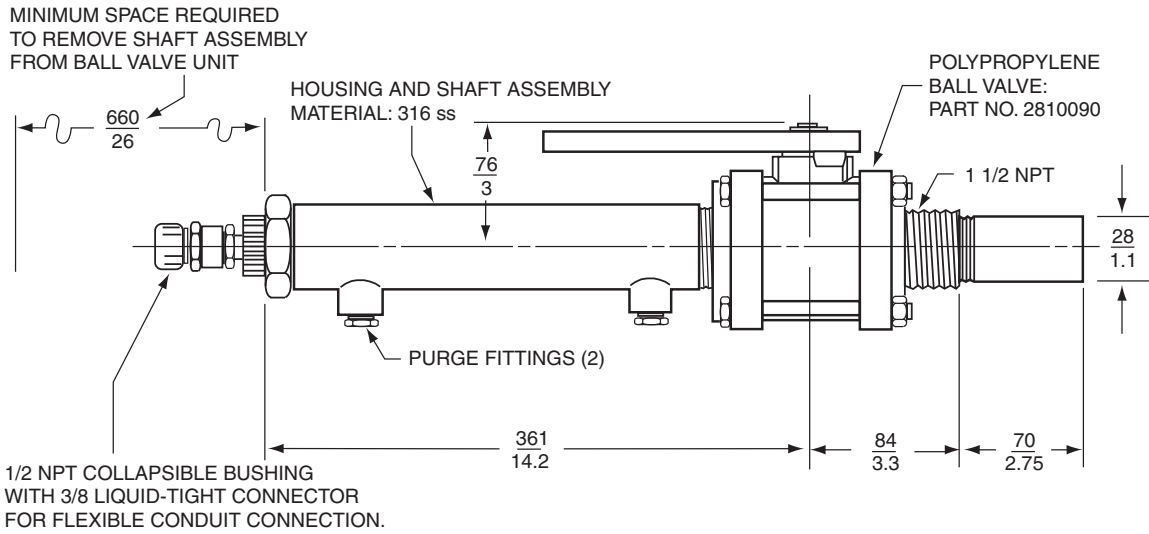

**BALL VALVE ASSEMBLY WITH TITANIUM PROCESS CONNECTION AND PURGEABLE HOUSING  
PART NUMBER BS806EP**

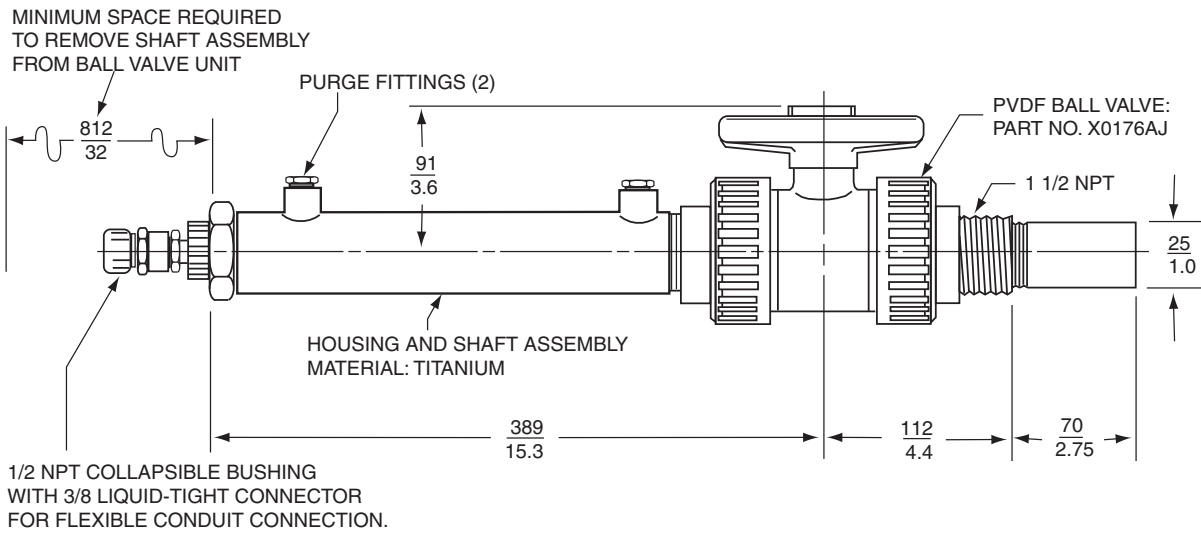

## ORDERING INSTRUCTIONS

1. Model Number
2. Cable Length, if nonstandard
3. Electrical Safety Specifications
  - ▶ CS Code for ATEX Certifications
  - ▶ Transmitter or Analyzer used for FM Approvals or CSA Certifications
4. Accessories
5. User Tag Data

## OTHER FOXBORO PRODUCTS

The Foxboro product lines offer a broad range of measurement and instrument products, including solutions for pressure, flow, analytical, temperature, positioning, controlling, and recording. For a list of these offerings, visit our web site at:

[www.fielddevices.foxboro.com](http://www.fielddevices.foxboro.com)