

# Foxboro® Model 84 Series

MNPT Vortex Meter



## Model 84 Series Description

The Foxboro® Model 84 Series Intelligent Vortex flowmeters are the highest performing vortex flowmeters on the market. These instruments are designed for flexibility and reliability in harsh process environments. No other vortex flowmeter measures up to the Model 84 for accuracy in liquid, gas, and steam. The Model 84 is now available in a MNPT (Male National Pipe Thread), and is well suited for direct replacement of turbine and magnetic flowmeters.

The Model 84 incorporates patented DirectSense technology and Flexible Tuning for unmatched performance. DirectSense technology eliminates unreliable, mechanical sensor linkages used in other vortex meters. The result is a simpler, more reliable design that is more sensitive to flow and less sensitive to noise. Combined with Flexible Tuning, the Model 84 has the widest flow range capability of any vortex meter. The Model 84 is also equipped with an on-board LCD Indicator/Configurator.

## Summary

The Foxboro Model 84 flowmeters are the highest performing vortex flowmeters on the market. The new Foxboro threaded vortex flowmeter is well suited for direct replacement of turbine, magnetic flow and orifice meters.

## Business Value

The Foxboro Model 84 Series MNPT (Male National Pipe Thread) Vortex flowmeter has high accuracy with reduced maintenance costs and direct replacement of existing flowmeters. No need to modify peripheral equipment.

# Model 84 Series

## MNPT Vortex Meter



### Features / Benefits

- No moving parts
- Direct replacement for turbine, magnetic flow and orifice meters
- Liquid, gas and steam service
- Currently available in 1 and 2 inch sizes
- Solar Powered (Nom. 12 vdc) version available
- Best accuracy delivers tighter process control and better material balance
  - 1.0% of reading in liquids, gas and steam
  - Best accuracy under operating conditions
- Widest flow range available for greater flexibility; greater than 40:1
- Patented Flexible Tuning improves accuracy under operating conditions
- HART® communication protocol for measurement integration
- DirectSense™ technology: performance and reliability backed by a lifetime sensor warranty

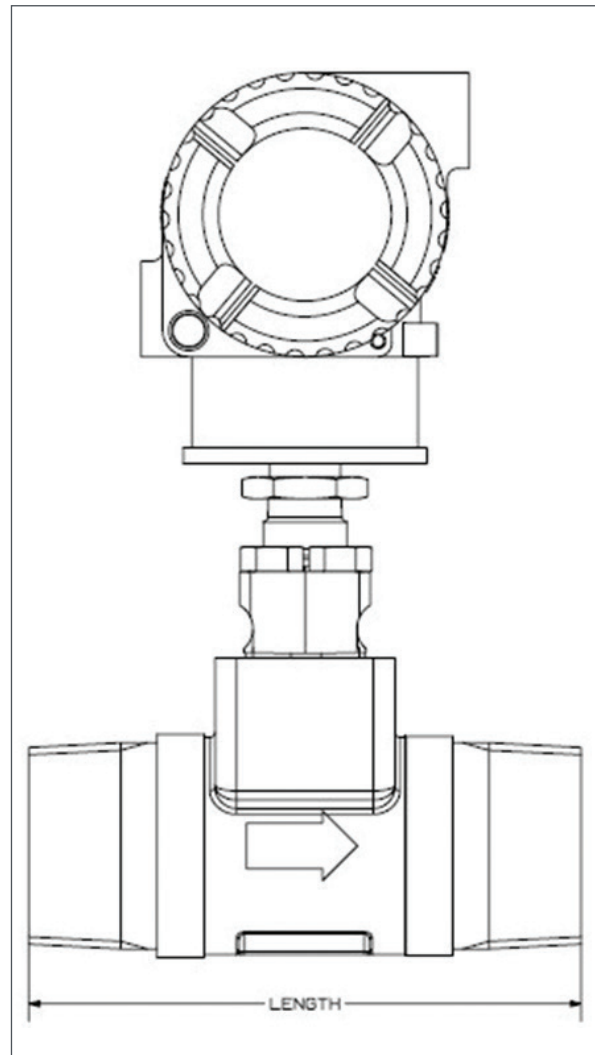

Size	Length +/- 0.125" (3.2mm)	
1" MNPT	4"	101.6mm
2" MNPT	6"	152.4mm

# Model 84 Series

MNPT Vortex Meter



## Best Accuracy Under Operating Conditions

Model 84 flowmeters utilize Flexible tuning to automatically compensate for operating influences and maintain accuracy under conditions outside the calibration lab:

- **Process temperature** - correction for K-Factor shift due to change in the process temperature.
- **Operation at low flow rates** - an algorithm, utilizing values of flowing density and viscosity, is embedded in the flowmeter to correct for nonlinearity in K-Factor at low flow rates ( $RD < 20\,000$ ).
- **Low Flow Cut-in (LFCI)** - eight selections of LFCI. The Model 84 also includes an automatic low flow cut-in feature that can be configured to automatically select LFCI.
- **Signal Conditioning** - a digital smoothing algorithm can be enabled to condition the raw vortex signal. This results in improved performance, particularly at low flow.
- **Low and high frequency filters** - these filters are set automatically based on the flowmeter configuration.
- **Adaptive filtering** - the flowmeter provides an adaptive mode which automatically adjusts the high and low frequency filters.

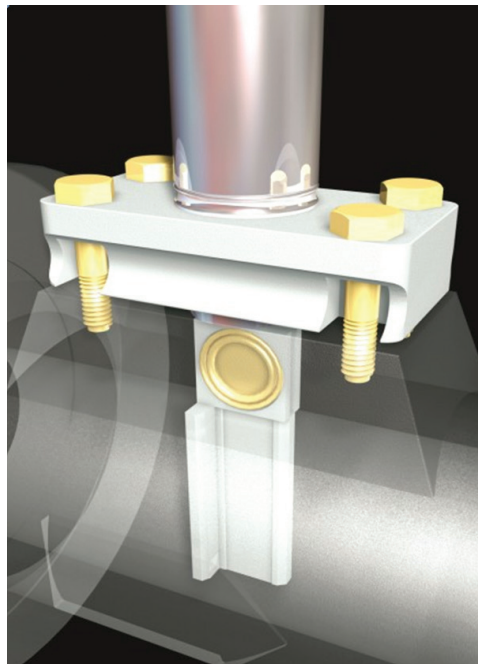

DirectSense™ technology with large sensing surface.

# Model 84 Series

## MNPT Vortex Meter



### Model Specifications

- Sizes:** 1" MNPT and 2" MNPT
- Accuracy:** ± 1.0% of rate\*
- Operating Pressure:** 1" MNPT: Equivalent to Class 1500, 2" MNPT: Equivalent to Class 900
- Construction:** 316 ss
- Sensor:** Stainless steel (CF3M) or Hastelloy (CW2M)
- Options:** Fluorolube, silicon, or unfilled options

\* Accuracy may vary based on operating conditions. Please use [www.flowexpertpro.com](http://www.flowexpertpro.com) flowmeter sizing program for accuracy at actual operating conditions.

### Ordering

Apply the appropriate ECEP number to a properly configured 84F-.01R1 .... for 1" NPT or 84F-.02R1 ... for 2" NPT. The ECEP number for 1" NPT is CO122601 and for 2" NPT is CO122601A. For more information please contact the Foxboro Global Client Support Center at 866-746-6477 (U.S. and Canada), 508-549-2424 (International).

Size	Approximate Minimum and Maximum Flow Rates for Liquids *			
	inches	L/min	U.S. gpm	BBLs/day
1" MNPT	5.5 - 215	8.9 - 56	30 - 2304	
2" MNPT	22 - 881	16 - 203	120 - 8640	

\* Assumes water at 60°F (15.6°C) and 100 PSIG (7 Bar). For more exact sizing please refer to [flowexpertpro.com](http://flowexpertpro.com)

Size	Approximate Minimum and Maximum Flow Rates for Gas *			
	inches	Actual M <sup>3</sup> /D	ACFD	SCFD
1" MNPT	73,086-3,040,000	2,558 - 106,400	20,000 - 832,048	
2" MNPT	215,571 - 12,594,286	7,545 - 440,800	59,000 - 3,447,058	

\* Assumes 0.6 SG natural gas at 60°F (15.6°C) and 100 PSIG (7 Bar). For more exact sizing please refer to [flowexpertpro.com](http://flowexpertpro.com)

Foxboro  
 38 Neponset Ave., Foxboro Massachusetts 02035 USA  
 Toll free within USA: 1-866-746-6477  
 Global: +1-508-549-2424

[www.fielddevices.Foxboro.com](http://www.fielddevices.Foxboro.com)

Life Is On

**Foxboro**  
 by Schneider Electric