

# Technical Specification

## Prefabricated 750kW Power Enclosure

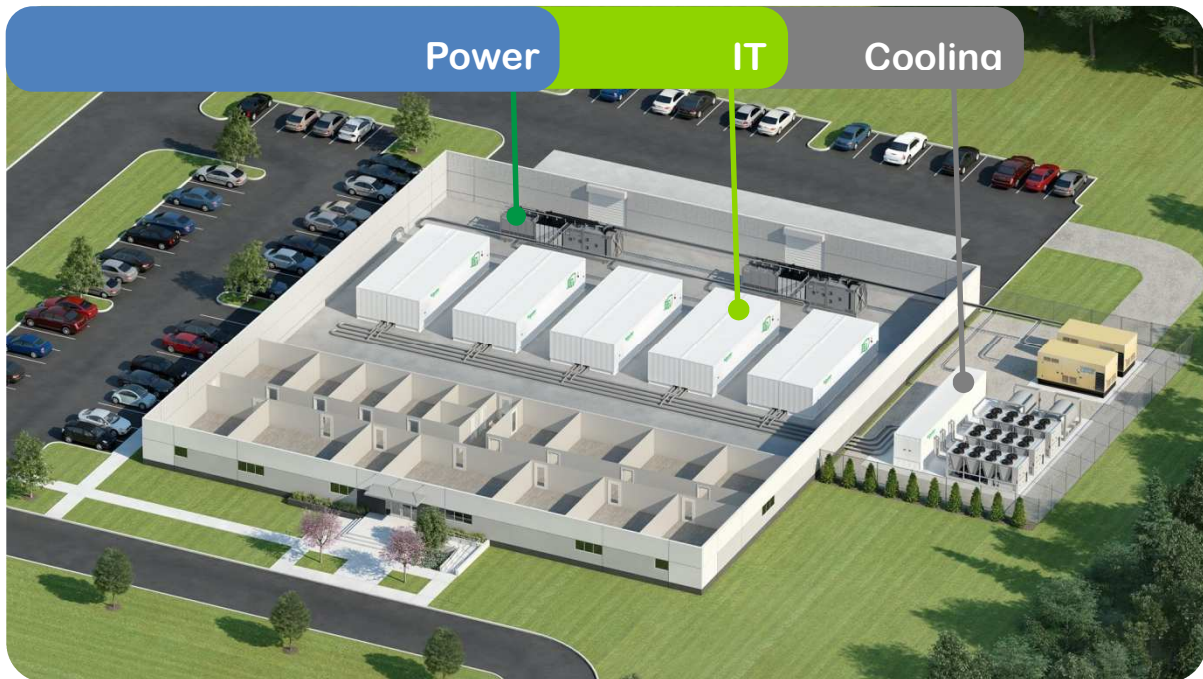

## Table of Contents

1. Introduction.....	4
1.1. Context .....	4
1.2. Main benefits.....	4
1.3. Scope of Work .....	4
1.4. Applicable Codes and Standards .....	5
1.4.1. Specification Codes and Standards .....	5
1.4.2. Safety.....	5
1.5. Quality Assurance.....	5
1.5.1. Material Workmanship.....	5
1.5.2. Quality Assurance System .....	5
2. Prefabricated Power Enclosure .....	6
2.1. Introduction .....	6
2.2. Concept and Dimensions for Prefabricated Power Enclosure .....	6
2.2.1. Prefabricated LV Power Solution with 750kW Galaxy VX UPS .....	6
2.3. Operating Conditions .....	8
2.3.1. Shipping conditions .....	8
2.3.2. Operating conditions .....	8
2.3.3. Handling .....	9
2.4. Construction.....	9
2.4.1. General .....	9
2.4.2. Steel enclosure construction .....	10
2.4.3. Floor.....	10
2.4.4. Walls and ceilings.....	10
2.4.5. Doors- Personnel access doors .....	11
2.4.6. Painting and Corrosion Protection.....	12
2.4.7. Surface Preparation .....	12
2.4.8. Steelwork Frame Coating.....	12
2.4.9. Coating System Quality Tests .....	13
2.4.10. Cable Glands .....	13
2.4.11. Air Renovation System (optional).....	14
2.4.12. Environmental Specification.....	14

3.	Electrical System .....	14
3.1.	Components.....	16
3.2.	Grounding .....	19
4.	Climate Control – Wall mounted Cooling .....	19
5.	Fire Suppression System (optional).....	19
5.1.	Fire Control Panel .....	20
5.2.	Smoke Detector .....	20
5.3.	Extinguishing system .....	20
6.	Monitoring System.....	21
6.1.	EcoStruxure for IT and/or Power (Optional): .....	23
6.2.	Environmental Monitoring .....	23
7.	Internal Power Module Equipment Details.....	24
7.1.	Schneider Electric: 750kW Galaxy VX .....	24
7.1.1.	Technical Specification.....	24
7.1.2.	VRLA Battery Solution:.....	26
7.1.3.	Lithium Ion Battery Solution:.....	26
7.2.	QED2 Switchboards.....	29
7.2.1.	Automatic Throw-over Controller.....	29
7.2.2.	Masterpact ACB NW Circuit Breakers.....	32
7.2.3.	SurgeLogic TVSS.....	32
7.3.	Cooling.....	33
7.1.	HVAC – Fresh Air Ventilation System - ERV.....	34
8.	Exclusions .....	35
9.	Pricing .....	36

# 1. Introduction

## 1.1. Context

The purpose of the document is to introduce and present the general technical specification of a 750kW prefab power enclosure offered by Schneider Electric.

This solution consists of a constructive solution of equivalent quality to the deployment of a low voltage electrical distribution system for a data center.

The environment has been designed to provide the following qualities:

- Usability for technical operations
- High quality, robust structure
- Reduced time to acquire and deploy

## 1.2. Main benefits

Prefabricated data center modules are the latest trend in the datacenter industry intended to decrease the time to acquire and deploy new datacenter capacity, improve the predictability and reliability of a new datacenter build and reduce upfront and ongoing capital expenditures.

All equipment in the proposed module are pre-installed and tested in our factories, reducing on-site construction risks and reducing time allocated for site works and commissioning.

Schneider Electric is a market leader in the data center business worldwide with complete integrated solutions including prefabricated modules, electrical distribution, cooling and IT space. Our installed base gives us a thorough knowledge of data center market evolution, future needs and an understanding of business challenges.

## 1.3. Scope of Work

### **This proposal covers a complete prefabricated module**

This document mainly covers the following topics:

- Enclosure structure and design
- UPS
- Electrical distribution system
- Fire suppression and detection
- Controls
- Power monitoring
- Climate cooling (HVAC)

## **1.4. Applicable Codes and Standards**

### **1.4.1. Specification Codes and Standards**

The enclosures should comply with the latest editions of the following standards and codes:

- BS6399-1997 Part 2 - Loading for Buildings, Code of practice for Wind Loads
- IEC 60529 - Classification of Degrees of Protection provided by enclosures
- ISO 12944 - Coating for Steel Work and Enclosures
- Meets IEC 60529 definition
- Tested to Ingress Protection level IP55

In addition to the above, the product specific safety standards are specified in each respective component section. The method of compliance verification by Schneider Electric (SE) is noted at the end of this standard.

### **1.4.2. Safety**

Product shall comply with all appropriate local agency standards.

## **1.5. Quality Assurance**

### **1.5.1. Material Workmanship**

All materials and workmanship are of a suitable type and quality to ensure that the enclosures will function satisfactorily and accordance with this specification.

### **1.5.2. Quality Assurance System**

Integrator must be compliant to ISO 9001:2008, with continuous in-house quality assessments that include but are not limited to:

- Maintenance of risk register
- Recording of non-conformances and follow-up corrective actions
- Continuous improvement and reviewing of targets and objectives
- Continuous assessment of procedures and work instructions to facilitate quality production
- Statistical record of Quality Control Tests

## 2. Prefabricated Power Enclosure

### 2.1. Introduction

The following proposal is for a 750kW power enclosure that is a separate prefabricated purpose –built structure. This weather proof module provides the low voltage power distribution system for the IT environment. Optionally, the power enclosure can provide non-UPS conditioned power for the building such as the mechanical plant. The enclosure itself shall consist of a single enclosure that is transportable by road or ship and meets applicable country and local standards and regulations.

### 2.2. Concept and Dimensions for Prefabricated Power Enclosure

#### 2.2.1. Prefabricated LV Power Solution with 750kW Galaxy VX UPS

##### Exterior View – Conceptual Example



### Conceptual Top-Level Layout View (Li-Ion Option Shown)



#### **Prefabricated power distribution system solution includes:**

- Single interlock enclosure depending upon final size, equipment layout and site requirements
- Uninterruptible Power System – 1 x 750kW for 750kW UPS capacity
  - Modular, Scalable High Efficiency UPS
    - Economy and ECONversion modes of operation
    - Full Load efficiency >96%
  - Standard: 5-6 minutes of run time BOL, 5-year battery design life (VRLA)
  - Optional: Lithium Ion battery solution, 10-12 year battery design life (Li-ION)
  - Internal Static Switch
- Low Voltage Distribution uL 891 Switchboards, distributing power from Main Input and/or Generator feed to the UPS as well as other mechanical loads.
  - Input Voltage 480 VAC, Output Voltage 480 VAC
- Electrical configuration
  - Main Input Feed
  - Generator Feed (**optional**)
  - Automatic transfer controller included for generator input (**optional**)
  - UPS input and output breakers

- Maintenance Bypass breakers with Kirk key Interlock
  - Critical Output Switchboard
  - Additional Feeder sections (**optional**)
  - Load bank breaker (**optional**)
  - Input and output power meters (see SLD for further details)
- Cooling – Uniflair wall mounted coolers in a N+1 configuration
  - Dehumidifier (**optional**)
- Automatic Fire Protection System and Detection
- Internal cable trays for wire routing
- Cable glands for power and fiber entrance into the module, bottom entry optional
- The entire assembly will be classified and labeled via Underwriters Laboratory (UL) utilizing the QXRA program – “prefabricated industrial commercial buildings and units”
- Netbotz 570 environmental monitoring system monitoring the following
  - Internal temperature
  - Internal humidity
  - Leak detection
  - External Door Status
  - Security camera monitoring
- EcoStruxure ready including power meters, EGX gateway, Ethernet switch w/ fiber port and wall mounting cabinet for monitoring and BMS equipment
  - EcoStruxure for Buildings or Power Monitoring (optional)
- Structural calculations to be performed on all units per the site conditions. A professional engineer stamp can be provided with additional fee

## **2.3. Operating Conditions**

### **2.3.1. Shipping conditions**

The enclosure will be designed and constructed for the transportation on sea (roll on-roll off) and on land (road or rail) throughout the world, and will be suitable for the environmental conditions imposed by those modes of transport. All materials used in the construction will be able to withstand extreme shipping environment temperatures ranging from -40°C (-40°F) to 70°C (158°F) without effect on the enclosure's strength or water tightness.

### **2.3.2. Operating conditions**

The enclosure ambient outdoor conditions at the installation site will range between

-20°C (-4°F) to 45°C (113°F) and 0 to 100% relative humidity. Enclosures shall be designed to be installed in altitudes up to 1000m. Environments outside of these parameters requires additional engineering and equipment.



The enclosure shall also be designed and constructed to withstand external loading conditions as prescribed by the International Building Code for the specified final location as a minimum. In addition, the following loading shall apply:

- a. Floor Loading: 12kPa (250psf) minimum Dead Load + Live Load (DL + LL) or as required for equipment exceeding this requirement. Each rack shall be assumed to be loaded to 909 Kg (2,000 lbs.).
- b. Maximum Deflection: Deflection of any base member shall not exceed L/400 (base member length divided by 400) at time of lift, and following final installation, with all applicable dead and live loads applied. SE will provide weights and locations of all equipment in each final configuration for calculation of final floor loading and deflection.
- c. Wind driven rain and dust intrusion: The enclosure should protect the electrical equipment against dust and water intrusion to meet IEC 60529 definition and testing to Ingress Protection level IP55.
- d. Roof snow loading: The roof should be capable of supporting a snow load of 2.4 kPa (50 PSF)
- e. Ceiling load: Interior ceilings must be capable of supporting 100 lbs./ linear foot supported at 3 ft. intervals to hold cable trays, conduit, ducts, interior lighting, etc.
- f. Wall Loading: Wind (Gust) = Maximum Basic Speed of 58 m/s (130mph). Wind gust load pertains to the enclosure walls only. Analysis will consider the enclosure to be fixed at the specified base locations and will analyze the walls with the max wind loads per this spec. There will be no considerations of foundation footings. The foundation design is to be analyzed by engineers at each installation site.
  - BS6399 1997 Part 2 'Loading for Buildings – Code of Practice for Wind Loads

### 2.3.3. Handling

The enclosure will be constructed to be capable of being handled without any permanent deformation which will render it unsuitable for use or any other abnormality during the following conditions:

- Lifting at the designated bottom lift bracket positions using slings with terminal fittings at sling angles of 30 degrees minimum to the vertical plane.

## 2.4. Construction

### 2.4.1. General

The enclosure is to be weather proof, insulated and is designed to be suitably robust to provide durability during its intended lifetime. The enclosure will be

classified as “Industrial” Use and Occupancy and “Type IIA” Building Construction. The summary of applicable standards is found in Appendix A.

During shipment and installation, the enclosure should arrive at site without damaging any internal components. The enclosure and associated materials are designed so not to exhibit signs of rusting or aging throughout its lifetime (with normal maintenance).

Refer to appropriate detail mechanical drawings for specific location of permanent components such as personnel access doors, equipment mounting features and other details.

#### **2.4.2. Steel enclosure construction**

The enclosure will be constructed with interlocking sheet metal wall and roof panels attached to a structural welded steelwork base frame. All steelworks will be built up by means of automatic or semi-automatic welding. All exterior welding, including that on base structure will be continuous to give watertight properties. All the welds, even spots, will have full penetration without undercutting or porosity.

#### **2.4.3. Floor**

The floor shall be ¼” minimum steel plate. The floor panels are to be securely attached to the base frame members and to be stitch welded to adjacent floor panels. If the floor panels need to be removable, they will be screwed to the base frame members with countersunk screws that are flush to under flush with the floor top surface.

The underside of the enclosure is insulated. The sheet metal base pans and side walls of the weldment is insulated with closed cell polyurethane spray foam insulation to provide minimum R-11 thermal insulation.

Alternate floor insulation construction would be fiberglass or mineral fiber (Rockwool) insulating batts or panels to provide minimum R-11 thermal insulation installed on the base pans and side walls of the weldment. The insulation would be protected from water intrusion by sheet metal panels attached to the underside of the base steel structure.

#### **2.4.4. Walls and ceilings**

The walls and roof are constructed as prefabricated and pre-coated interlocking sheet metal panels. Typical sheet metal thickness is 2.0mm but may vary as required. The wall panels are attached to the base steelwork frame and to each other in a watertight manner using self-drilling sealing type screws or sealing type rivets.

Roof panels are attached to the wall structure and to each other in a watertight manner using self-drilling sealing type screws or sealing type rivets. Roof panels will have 2 degrees minimum pitch to allow water runoff. There shall be no instance where water may pool on the roof.

The standard construction of the enclosure walls will not have a fire rating (fire rating optional)

The enclosure walls will be designed to allow an optional, alternate construction of walls with 1 hour fire rating and listed per UL 263. Class B or better rated materials (flame spread 26-75, smoke developed 0-450) per UL 723 shall be used. In addition, they shall be classified "B" per BS 476 Part 22/EN 13501-1 and certified for European compliance by meeting EN 13823 and ISO1182 or ISO1716.

The compliance with the above must be proved by test reports and declaration of performance (DoP) per Annex III of European Construction Products Regulation (305/2011). Any applicable regulatory mark, including NRTL Listing and CE Marking, must be affixed to the component.

Standards for classifying and evaluating interior walls and ceiling are shown in Appendix A.

- Wall thermal insulation is to be R-15 minimum. Roof thermal insulation is to be R-30ci minimum. Note: this will meet 2015 IECC requirements for climate zones 1 thru 6.

Interior finish and color of the walls and ceilings is to be approved by SE. Install wall and ceiling sheets with finish edges and corner moldings for good aesthetics. Hidden fasteners are preferred. If fasteners are visible, the color should match the wall color as close as possible using standard fastener colors

#### **2.4.5. Doors- Personnel access doors**

All personnel doors shall conform to the latest version of the Steel Door Institute (SDI) ANSI/SDI – 100-91 – Recommended Specifications for Standard Steel Doors and Frames. The main access door must be sized appropriately to move all equipment into and out of the enclosure. Alternate doors may be sized for personnel access only. The doors should be positioned per the detail drawing specification.

Door and door frame to accommodate optional electronic entry system.

The door core should include insulation to provide minimum R-6 thermal insulation.

Optional constructions with 1 hour fire rated walls will require that the door assembly be ¾ hour minimum fire rated. It shall be tested to NFPA- 252 as verified and listed per UL10C (for NAM). In EMEA, it shall be tested and certified for European compliance by meeting 1 hour fire rating per EN 1634-1.

The compliance of door assembly including its components with the above must be proved by test reports and declaration of performance (DoP) per Annex III of European Construction Products Regulation (305/2011). Any applicable regulatory mark, including NRTL Listing and CE Marking, must be affixed to the component.

Standards for door assembly and components are shown in Appendix A.

#### **2.4.6. Painting and Corrosion Protection**

The coating system, preparation and application shall meet the requirements of ISO12944 for a C4 industrial environment and designed for medium durability (5 to 15 years to first major maintenance).

All coatings shall be applied inside an environmentally controlled (air quality, temperature and humidity) paint booth with ventilation and filtration provisions in accordance with the local environmental agency standards and in accordance with the coating manufacturer's requirements. Coating performed in outside, ambient air conditions shall not be acceptable.

#### **2.4.7. Surface Preparation**

1) All steelwork surfaces prior to forming or after will be de-greased and shot blasted to Swedish Standard SA 2.5 to obtain the surface roughness at 25 to 35 microns which can result in the removal of all the rust, dirt, mill scale and all other foreign materials.

2) All fasteners such as bolts/nuts, washers, self-tapping screws, which are not mentioned in this Spec. will be electro zinc plated to 13 Microns minimum, unless specified otherwise.

3) Sealant is applied to the perimeter of the floor, all overlapped joints, all holes for bolts and nuts and all places where water may leak to prevent water entry.

#### **2.4.8. Steelwork Frame Coating**

##### **1. Prior to Assembly**

All the structural steel surfaces will be coated with primer paint immediately after shot-blasting.

## **2. After Assembly**

All the weld joints will be shot-blasted to remove all the welding fluxes, spatters, burnt primer coatings caused by welding heat, and other foreign materials, and followed with the primer paint operation immediately.

### **2.4.9. Coating System Quality Tests**

The following minimum coating system test results shall be certified (from in process, manufacturer's samples) by independent laboratory tests performed under ASTM or equivalent criteria. Copies of the test results and certification shall be submitted for review:

- Corrosion Resistance (Salt spray): Passes 2250 hours per ASTM-B117 or ISO 9227
- Color & Gloss Retention: Only slight change after 250 and 1000 hours in Q.U.V. test
- Oil Resistance Immersion: Passes both 72 hours at 78 degrees F and 72 hours at 212 degrees to 220 degrees F
- Hardness: Minimum H pencil hardness
- Abrasion Resistance: 3000 cycles per ASTM D4060 or ISO 7784-2 using Teledyne Taber with CS-10 wheels
- Chemical Resistance: Excellent
- Wash ability & Stain Resistance: Excellent

Humidity Resistance: 1000 hours per ASTM-D2247 or ISO 6270 run at 113 degrees F

Structural framework will be made of steel with a fully welded design to support the installed equipment.

### **2.4.10. Cable Glands**

Roxtec cable glands or equivalent will be installed at all cabling and piping interface points that enter or exit the module. Cable glands provide thermal, fire, and water protection for the module. The cable gland is easily configurable to adapt to the number and dimensions of cables and pipes that enter the module as it provides isolation and protection fitting its compression unit.

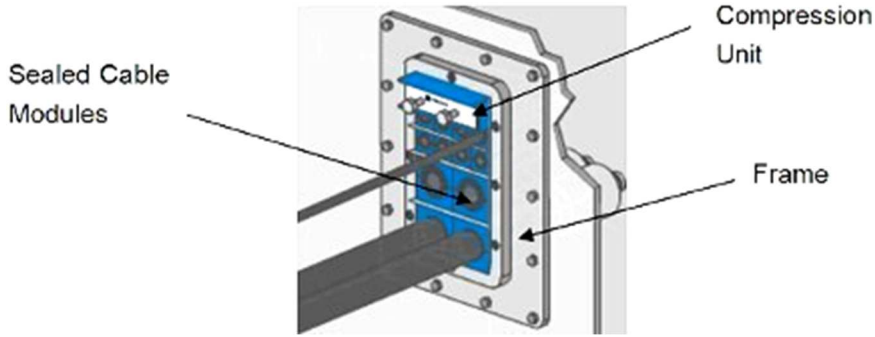

#### 2.4.11. Air Renovation System (optional)

Each enclosure can be equipped with an air renovation system which will refresh the air inside the module with outside air at a rate to comply with local regulations for hydrogen control. The air renovation system includes a radial fan sections and 2 filter sections.

#### 2.4.12. Environmental Specification

**Operating Min/Max Temperature:** 0° C to 40° C  
(Recommended Battery temperature: 25° C)

**Operating Humidity Range:** 0 – 95% Non- Condensing

**Audible Noise:** 74 dB (a) @ 1m from surface of unit)

### 3. Electrical System

Following is the description of a standard low voltage electrical system provided inside the module. The electrical system can be customized to meet specific customer and site requirements.



750kW 480V GVX  
Power Enclosure Ele

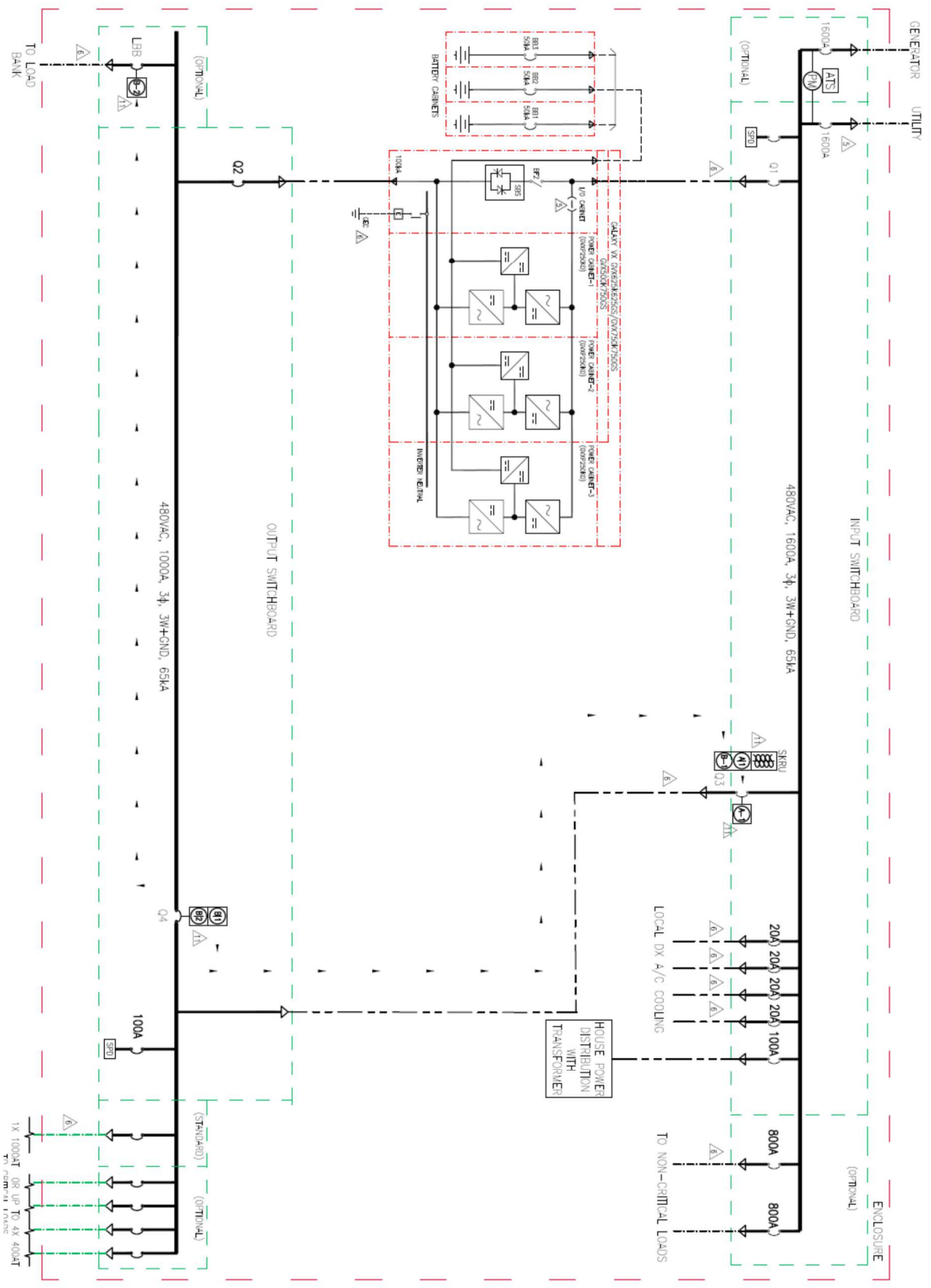

### 3.1. Components

- **Main Input Switchboard:** (1) 480V 1600A three-phase electrical switchboard UL /cUL 891, 65kA TN-S type, construction type. The switchboard incorporates (1) main input circuit breaker, Square D NW Type, fixed mounted 100% rated at 1600A. The switchboard will feed the UPS system, provide a path for maintenance bypass of the UPS system as well as other mechanical loads. The additional feeder for the UPS system is a fixed mounted 1200AF/1200AT, 65kA, Type Square D NW. A Square D NW Type, fixed mounted 100% rated at 12000AF/1000AT, 65kA Type SquareD NW circuit breaker to feed external maintenance bypass of the UPS system with a Kirk Key Interlock system. In addition, the main panel includes a 100A SPD with a surge rating of 240kA, all breakers 250A and larger have metering and communication option, a PM5563RD w/ display power meter and Ethernet gateway for external access. Additional, (4) 60AS/50AT 480V 80% Rated 65 kA 3 Pole UL, Group Mounted Electronic Circuit Breaker: Type HJ feeder breakers to support electrically the wall mounted coolers. (2) 100AS/100AT 480V 80% Rated 65 kA 3 Pole UL, Group Mounted Electronic Circuit Breaker: Type HJ feeder breakers to support surge protection device and house load panel
- **Critical Switchboard:** (1) 480V 1000A three-phase electrical switchboard UL/cUL 891, 65kA TN-S, construction type. (1) UPS output circuit breakers at 1200AF/1000AT, Square D fix mounted 100% rated 65kA, Type NW. (1) output circuit breakers at 1200AF/1000AT, Square D fix mounted 100% rated 65kA, Type NW. In addition, (1) 100A SPD with a surge rating of 240kA is included on the output switchboard. All breakers to have metering and communication option including an optional PM8244 power meter on the output.
- **Generator Input Section (Optional):** Incorporates (1) Generator input circuit breaker, Square D NW Type, fix mounted, 100% rated at 1600A. This section will allow for input source selection between the Utility mains and the Generator feed. See Woodward (DTSC200) source controller section for additional details.
- **Additional Feeders (Optional):** Both the Main Input and Critical Switchboard can provide an additional section for extra feeders. Input switchboard: (2) group mounted 800AS/800AT 65kA 100% rated 65kA, Type Square D PJ circuit breakers. Critical output switchboard: (4) group mounted 400AT 100% rated 65kA, Type Square D LJ circuit breakers.
- **Load Bank Breaker (Optional):** A 1000A 100% rated Square D Type NW Load bank circuit breaker with a Kirk key interlock will be provided.



## UPS Details:

- **Uninterruptable Power System:** (1) UPS Galaxy VX 750kW part #GVX750K750GS. UPS will be equipped with a high efficiency mode of operation resulting in full load efficiencies >96 up to 99% efficiency in economy mode of operation.
  - Output Power Factor = 1
  - 100% rated static bypass support overload continuous at 125%
  - Short circuit withstand 100kAIC standard
  - Seismic compliant
    - OSHPD
    - ICC-ES AC 156
- **Battery Racks:** Minimum of 4 strings of (160) Enersys Data Safe 12HX505+ Battery System with Intrapak IP3 Battery cabinets (GVX- 160H505- 480- 4 4D500), estimated 5-6 minutes runtime, beginning of life @ 100% load. Battery design life, 5 years, 25 Degree C.
  - **Optional** Lithium Ion batteries can be provided to decrease the total weight and footprint while increasing the number of discharge cycles for the battery system. The battery racks shall be front access only, part number #ELPM182 136S1P to provide up to a total of 20 minutes of runtime beginning of life at 100% load.
  - **Schneider Electric Lithium Ion Rack type G\***
    - Nominal voltage: 516.8V
    - Operation voltage: 408V – 571V
    - Capacity: 34.6kWh
    - Nominal Power:231kW
    - Modules include battery management system (BMS)
    - Minimum expected battery life > 12 years
- **Automatic Throw-over Controller:** ATS control is provided to the main input switchboard from a Woodward brand genset controller (DTSC200) mounted in the Generator Input Section
  - Normal Open transition (standard)
- **Main Power Cabling:**

- Power lines from Main Switchboard to each UPS input
- Power Lines from UPS system to Critical Switchboard
- Internal cabling for maintenance bypass between switchboards and connection to the critical output switchboard
- Internal cabling between all ancillary equipment such as panelboard, step down transformer, lighting, emergency lighting, etc.,

- **Lighting:**



- 4' industrial grade LED Lighting or equivalent.
- The Vaportite LED Series is an energy efficient industrial Vaportite fixture that features rugged and durable construction. The Vaportite LED incorporates a full metal fixture liner inside a reinforced fiberglass housing with a high impact diffuser. This Vaportite series is suitable for interior and exterior applications and can be surface or chain mounted. The Vaportite LED Series has been designed for maximum operation in commercial institutional and industrial environments and can operate in a wide range of temperatures (-20°C to 25°C) and is ideal for cold storage environments.
- The above light fixtures are controlled by a single lighting control. Additional controls can be added or upgraded as an option.
- Long-Life LED system coupled with electrical driver to deliver optimal performance. LED's available in 3500, 4000 and 5000K with a CRI ≥ 85. Projected life is 60,000 hours at 91% lumen output. cULus listed. Electronic drivers are available for 120-277V applications. A 0-10V dimming control is available (standard). IP65 rated and NSF certified (4' only).
- UL/cUL listed for Wet location. RoHS compliant, and LED modules comply with IESNA LM-79 and LM-80 standards.
- - 64W Light Fixtures are installed above center aisle throughout the length of the enclosure.

- The above light fixtures are controlled by a single lighting control. Additional controls can be added or upgraded as an option.
- **Emergency lighting:**
  - (2) Exit Sign/Emergency lighting block mounted above each door or equivalent
- **Additional Power Metering**
  - Additional power meters can be added to the input panels as an option.

### 3.2. Grounding

The power enclosure includes an integrated grounding system. The customer will supply a ground from the external system to a grounding bar on the outside of the skid structure. All internal components will be grounded to this bar via the internal electrical system. The module is designed to connect to a TN-S type grounding system.

## 4. Climate Control – Wall mounted Cooling

- (4) Uniflair WMF0661 460V, 60hZ wall mounted coolers configured in a N+1 architecture for full load operation

<b>750kW 480V Power Enclosure Performance Calculations</b>		
<b>Total Sensible Load</b>	kW	41.92
<b>Nominal Max Ambient Temperature</b>	°F	113
<b>Nominal Altitude</b>	m	999.9
<b>Nominal RAT</b>	°F	85
<b>Single Cooler Sensible Capacity</b>	kW	14.9
<b>Single Cooler Airflow</b>	CFM	2578

## 5. Fire Suppression System (optional)

The fire protection system is designed to prevent, detect and extinguish possible fires inside the rooms. This will be an automatic system innocuous for people, goods and friendly environment. It will include the following equipment:

- Fire Control Panel
- Smoke Detection System
- Fire extinguishing system based on Novec1230.

## 5.1. Fire Control Panel



The fire panel controls the fire detection and extinguishing system.

The panel can monitor two distinct areas, can trigger at least 2 levels of alarms, and incorporate a delay to evacuate the room before activating the extinguishing system. The system can also be activated by a manual switch attached to the panel.

This solution will implement an ANSUL AutoPulse 542R fire panel with following features:

- Suitable for multiple types of Suppression: Clean Agent, Carbon Dioxide, Pre-Action Sprinkler/Deluge, and Water mist Systems
- Microprocessor based with hardware and software integration designed to guarantee reliability
- Cross zone, sequential manual release, abort, water flow and supervisory detection types
- Three Class B, Style Y notification appliance circuits rated for 2.0 amps @ 24VDC
- Dedicated release circuits compatible with agent release or solenoid actuation
- Five Class B, Style B initiating circuits
- Optional Class A modules for notification appliances/releasing circuits and initiating circuits
- Alpha-numeric LED display for status and troubleshooting
- Programmable pre-discharge and discharge timers
- Resettable and continuous auxiliary output power
- Small surface or flush mount enclosure with removable door
- Approved for releasing device service and sprinkler supervisory
- Built-in Gentex and System Sensor synch protocol
- Steel enclosure 19" x 16.65" x 5.25"
- Enclosure equipped with .50" wide lip for flush mounting
- (Additional control panels and features available upon request)

## 5.2. Smoke Detector



Smoke Detection is achieved by photoelectric smoke detectors mounted to the roof of the enclosure and spaced evenly among the enclosure. All sensors will be wired to create a single detection circuit wired back to the fire panel.

## 5.3. Extinguishing system

The automatic fire extinguishing system will be able to extinguish the fire quickly using clean extinguishing agents that don't damage the equipment to be protected. The gas release will be ordered by the fire panel at the second alarm level and once the timeframe expires. A description of the system is provided below

## DESCRIPTION



Ansul Clean Agent Containers are used in fire extinguishing systems to store the Clean Agent until a fire develops and the agent must be released. The Clean Agent is retained in the container by a solenoid and an Electric Actuator Assembly. An electric signal initiates the actuator and the Clean Agent is released. The actuator is can be controlled both electrically and manually.

Ansul Clean Agent Containers have passed extensive testing by Factory Mutual and Underwriters Laboratory. Clean Agent containers can be filled in 1 pound (0.5 kg) increments to their maximum capacity.

## SPECIFICATION

- Fill Range: 116 to 280 lbs./ft<sup>3</sup> (630 to 1121 kg/m<sup>3</sup>)
- Fill Increments: 1.0 lbs. (0.5 kg)
- Valve requirements in accordance with DOT regulations
- Container Construction: Carbon Steel Alloys
- Paint Options: Red (default)
- Container Ratings: DOT 4BW450
- Actuation Methods: Electric/Manual/Pneumatic (capable but used for multiple containers)

## APPROVALS

- UL/cUL Listed
- FM Approved

Gas, pipe, pipe fittings, bottle fittings, chrome steel diffusers, stainless diaphragms, manual pulls, system abort button, and protected local labels will be included.

## 6. Monitoring System

The Power enclosure shall be capable of integrated power monitoring system that will monitor and allow for remote access of power usage and component level information

- Power Meter PM5563RD series on Mains and Output Feeder or equivalent
  - Included communication card
  - 3 CTs
  - Display
- EGX Gateway for Modbus communication (BMS)
- Ethernet switch with Fiber port for Communication via network/ TCP/IP
- Aux. contacts on main breakers for status
- Micrologic trip units 6.0 P or E
- Terminal strip for easy wire connections

- Wall mounted cabinet to house monitoring equipment

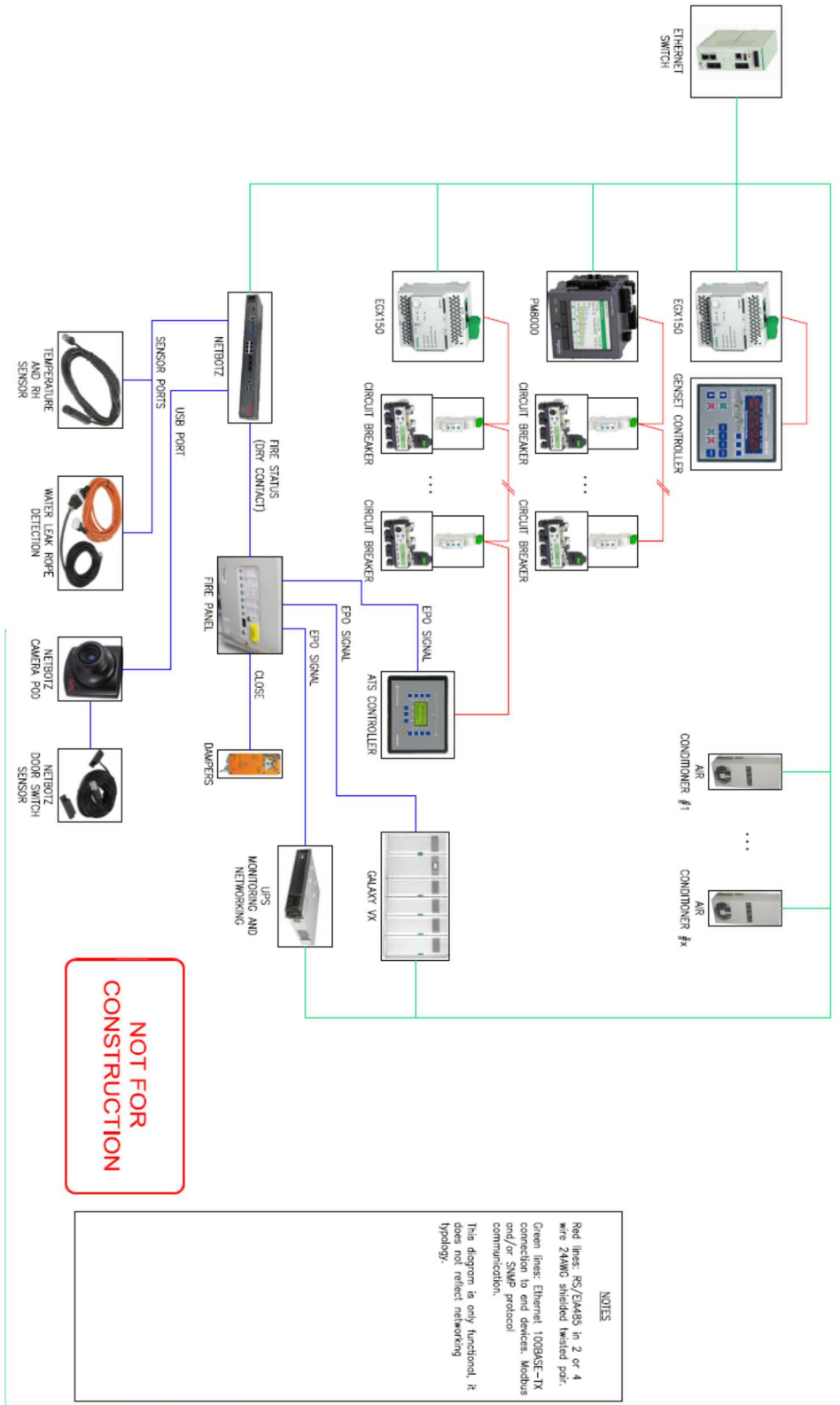

## 6.1. EcoStruxure for IT and/or Power (Optional):

- The power enclosure can be configured with Ecostruxure IT and/or Power Monitoring Expert (PME) and the associated cabling, meters and switches to communicate with all equipment integrated within the power enclosure. Our Critical Facility Management integrates two components of the EcoStruxure™ architecture – EcoStruxure Power Monitoring Expert, which provides power monitoring, control, and analysis, and EcoStruxure IT, which monitors IT infrastructure making it more reliable & efficient while simplifying management by offering complete visibility, alerting & modeling tools. Customers can receive data, alerts, predictive analytics, and system advice on any device to optimize availability and efficiency in the white space. This integration enables intelligent, comprehensive insight into data center infrastructure for both electrical and IT systems.



## 6.2. Environmental Monitoring



Each Module includes a Netbotz 570 rack mounted appliance that will monitor the environment and provide security monitoring for the module. The Netbotz 570 is a scalable system which will allow additional sensors and devices to be added to the system to scale to the final needs of the user.

The Netbotz 570 system will monitor the following information inside the module:

- 2 temperature/humidity sensors
- 1 leak detection rope
- The status of all the external doors
- Security cameras at each external door location
- The dry contact alarm status on the fire panel.

## 7. Internal Power Module Equipment Details

### 7.1. Schneider Electric: 750kW Galaxy VX

(1) UPS Galaxy VX 750kW part #GVX750K750HS. UPS will be equipped with a high efficiency mode of operation resulting in full load efficiencies >96 up to 99% efficiency in economy mode of operation.

- Output Power Factor = 1
- 100% rated static bypass support overload continuous at 125%
- Short circuit withstand 100kAIC standard
- Seismic compliant
- OSHPD
- ICC-ES AC 156



Figure 1: MGE Galaxy VX UPS

#### 7.1.1. Technical Specification

<i>Output</i>	
<b>Output power capacity</b>	750 kWatts / 750 kVA
<b>Max Configurable Power (Watts)</b>	750 kWatts / 750 kVA
<b>Nominal Output Voltage</b>	480V 3PH
<b>Output Frequency (sync to mains)</b>	50 Hz, 60 Hz
<b>Output Frequency (not synced)</b>	60Hz +/- 0.1% for 60Hz nominal
<b>Load Crest Factor</b>	3 with THC <5%
<b>Topology</b>	Double Conversion Online
<b>Waveform type</b>	Sine wave
<b>Overload Operation</b>	150% for 1 minute 125% for 10 minutes
<b>Output Voltage THD</b>	< 2% linear load and <3% non-linear load
<i>Input</i>	
<b>Nominal Input Voltage</b>	480V 3PH
<b>Input frequency</b>	40 - 70 Hz
<b>Input Total Harmonic Distortion</b>	Less than 3% for full load
<b>Maximum Short Circuit Withstand (Icw)</b>	100.0kAmps



<b>Maximum Input Current</b>	1092.0A
<i>Batteries &amp; Runtime</i>	
<b>Battery type</b>	No internal battery - uses external battery system
<b>Nominal Battery Voltage</b>	480Vdc
<b>End of Discharge Battery Voltage</b>	384 Vdc
<b>Efficiency</b>	<a href="#">View Efficiency Graph</a>
<i>Communications &amp; Management</i>	
<b>Pre-Installed SmartSlot™ Cards</b>	<a href="#">AP9635</a>
<b>Control panel</b>	7" Touch Screen Display
<b>Audible Alarm</b>	Audible and visible alarms prioritized by severity
<b>Available SmartSlot™ Interface Quantity</b>	2
<i>Physical</i>	
<b>Maximum Height</b>	1970mm, 197.0cm
<b>Maximum Width</b>	3300mm, 330.0cm
<b>Maximum Depth</b>	900mm, 90.0cm
<b>Net Weight</b>	2669kg. / 5885 lbs
<b>Color</b>	White
<i>Environmental</i>	
<b>Operating Temperature</b>	0 - 40 °C
<b>Operating Relative Humidity</b>	0 - 95% non-condensing %
<b>Operating Elevation</b>	0-999.9meters
<b>Storage Temperature</b>	-15 - 40 °C
<b>Storage Relative Humidity</b>	0 - 95% non-condensing %
<b>Storage Elevation</b>	0-15000meters
<b>Audible noise at 1 meter from surface of unit</b>	69.5dBA
<b>Online thermal dissipation</b>	174332.0BTU/hr
<b>Protection Class</b>	IP 20

## Conformance

<b>Approvals</b>	cUL Listed, C-tick, CE, IBC 2012, IEC 62040-1-1, IEC 62040-2, IEC 62040-3, IEC 62040-4, ISTA 2B, UL 1778 5th edition
<b>Standard warranty</b>	1-year on-site repair or replace with factory authorized Start-Up



### 7.1.2. VRLA Battery Solution:

- Intrapak GVX Battery Cabinets: QBATGVX-QNBO91457 - Energys Data Safe 12HX505+ Battery System with Intrapak Battery cabinets, estimated 5-6 minutes runtime beginning of life @ Full load

- a. The battery cabinet shall feature valve regulated, high-rate discharge, lead acid batteries which provide energy to the support the load during a momentary loss of input power to the rectifier.
- b. Non-redundant construction - one battery string per cabinet.
- c. Each battery cabinet shall require front access only for installation, service and maintenance.
- d. Each battery cabinet shall feature a DC rated circuit breaker. The circuit breaker within the battery cabinet shall only provide protection to the battery string within that battery cabinet.
- e. The UPS shall incorporate a battery capacity test that will be capable of determining available runtimes.
- f. The battery cabinets shall come in a remote configuration and an optional remote adjacent configuration.
- g. Configuration will support top entry only.

- Battery Breaker Cabinet: Optional.  
Floor-mount battery breaker cabinet available. Cabinet will include DC breaker rated for specific UPS maximum current draw. Battery Breaker Cabinet shall support top or bottom entry. Battery breaker shall include UVR and Aux contacts to support monitoring by UPS modules

### 7.1.3. Lithium Ion Battery Solution:



The Schneider Electric™ Li-ion battery solution for three-phase UPSs is a high-value, innovative energy storage protection solution for data centers, industrial processes, or critical infrastructure. This solution is supported by Schneider Electric Symmetra™ MW, Galaxy™ 7000, Galaxy VM, and Galaxy VX UPSs and brings the following benefits:

- Significantly reduced battery footprint and weight to allow for a more
- effective use of space

- Double the life and simplified maintenance vs. traditional batteries
- Reduced cooling requirements
- Improved backup storage predictability and manageability (BMS included)
- Reduced TCO
- Each module contains a battery management system

○ **Schneider Electric Lithium Ion Rack Type G\***

- Nominal voltage: 516.8V
- Operation voltage: 408V – 571V
- Capacity: 34.6kWh
- Nominal Power:231kW
- Modules include battery management system (BMS)
- Minimum expected battery life > 12 years

<b>Output</b>	
Battery Capacity (mAh)	67000
Battery Output Voltage	30.40
<b>Batteries &amp; Runtime</b>	
Battery type	Lithium Ion

System component			
	Cell	Module	Rack type G*
Description	Cell	Module	Rack type G*
Configuration	1S1P	8S1P	136S1P
Dimensions (HxWxD)	4.95 x 1.8 x 6.85 in; 125.7 x 45.6 x 173.9 mm	6.4 x 8.5 x 16.3 in; 163 x 216 x 414 mm	80.9 x 25.6 x 23.6 in; 2055 x 650 x 600 mm
Weight	4.14 lb (1.88 kg)	37.5 lb (17 kg)	1212.5 lb (550 kg)
Nominal voltage (V)	3.8 V	30.4 V	516.8 V
Operating range (V)	2.7 V – 4.2 V	24.0 V – 33.6 V	408 V – 571 V
Capacity (kWh)	0.254 kWh	2.04 kWh	34.6 kWh
Nominal power (kW)	1.7 kW	13.6 kW	231 kW

\*MCCB: 600 A; DC fuse: 500 A. Three-year warranty included. Optionally, extend the warranty up to 10 years.

Battery mounting	Enclosed battery cabinet
Battery Placement	Battery Cabinet
Battery manufacturer	Samsung
Battery Service Life	10 – 15 years
<b>Physical</b>	
Maximum Height	2055mm, 205.5cm
Maximum Width	650mm, 65.0cm
Maximum Depth	599mm, 59.9cm
Net Weight	549.98kg
Shipping weight	549.98kg
Shipping Height	2200mm, 220.0cm
Shipping Width	1200mm, 120.0cm
Shipping Depth	600mm, 60.0cm
Color	White
<b>Environmental</b>	
Operating Temperature	18 - 28 °C
Storage Temperature	0 - 40 °C
Storage Relative Humidity	0 - 60 %
<b>Conformance</b>	
Approvals	CE
Standard warranty	3 years repair or replace
<b>Sustainable Offer Status</b>	
RoHS	Compliant
REACH	REACH: Contains No SVHCs
Battery Directive	Compliant

## 7.2. QED2 Switchboards



SquareD Power-Style QED-2 uL 891 switchboards offer the flexibility to meet the simplest or most complex critical power requirements. These switchboards can be built to meet a simple multi-section application or highly customized for critical auto-throw-over system applications. QED-2 offers the proven flexibility and reliability to keep your system up and running regardless of system complexity.

### 7.2.1. Automatic Throw-over Controller



Woodward's DTSC-200 is the ultimate control for new ATS (automatic transfer switch) builds and retrofits. A complete measurement and protection package, it easily configures to Utility-to-Generator, Generator-to-Generator, or Utility-to-Utility systems for open, delayed, or closed-transition transfer with synch-check to ensure the smoothest possible transfers.

High-end features like transfer inhibit, source priority selection, load shed, motor load disconnect, elevator pre-signal, and engine exerciser timers come standard in this incredibly versatile, cost-effective control.

- Normal Open transition (standard)
- Feature overview:
  - Configurable for open, delayed, and closed transition transfer
  - Configurable for Utility-to-Gen, Generator-to-Generator, and Utility-to-Utility applications
  - Closed transition transfers can be accomplished in times < 100ms
  - In-phase monitoring (sync-check)
  - Load/no load test functionality
  - Engine exerciser (load/no load test) routine with fully adjustable interval
  - Peak shaving mode
  - Load shedding
  - Extended parallel time (for closed transition transfers that take longer than 100ms)
  - Transfer and/or re-transfer inhibit
  - Source priority selection
  - Elevator pre-transfer and motor load disconnect timers
  - Event/Alarm log system with real time clock
  - Internal breaker interlock utilizing discrete inputs for breaker position detection

- Freely configurable discrete I/O with support for external I/O expansion units (e.g. Woodward IKD 1)
- RS-232, RS-485 and CAN bus interfaces for remote control and visualization purposes
- Supports CANopen and Modbus RTU protocols
- PC and/or front display configuration
- 128x64 pixels graphic LCD display
- LogicsManager provides programmable logic functions that eliminate relay logic or PLC`s
- True RMS voltage, current and power sensing
- LEDs for source availability and breaker status

<b>Specification</b>	
Power supply	12/24Vdc (6.5 to 40 Vdc)
Consumption	max. 8W
Ambient temperature (storage)	-30 to 80 °C / -22 to 176 °F
Ambient temperature (operation)	-20 to 60 °C / -4 to 140 °F
Ambient humidity	95 %, non-condensing
Voltage AC input	120Vac and 480Vac true RMS
Accuracy	Class 1
Current AC input	1A or 5A true RMS, isolated
Accuracy Iac	Class 1
Discrete inputs (isolated)	Range: 12/24Vdc (8 to 40Vdc)
Relay outputs	Isolated
<b>Housing</b>	
Front panel mounting	Plastic housing
Dimension (WxHxD)	219 × 171 × 61 mm

Sealing (front/back)	IP65/IP20
Weight	Approx. 800 g

Technical Specification: Woodward DSC200			
Power supply	12/24 VDC (6.5 to 40.0 Vdc; not buffered)	Discrete inputs	isolated
Inrush current	max. 50A peak, 1ms	input range	12/24 Vdc (8 to 40.0 Vdc)
Input capacitance <sub>x</sub>	2000 $\mu$ F	Input resistance	approx. 20 k $\Omega$
Intrinsic Consumption	max. 8 W / 3 W ( Power Savings Mode)	Discrete outputs Group A [R 1-4]	isolated
Ambient Temperature (operation)	-20 to 60° C / -4 to 140° F	Contact material	AgCdO
Ambient Temperature (storage)	-30 to 80° C / -22 to 176° F	Load (GP)	2.00 Aac@250 Vac / 2.00Adc@ 24 Vdc
Max. operating altitude	2000 m (6,500 ft)	Discrete output Engine Start [R5]	isolated
Ambient Humidity	95%, Non-condensing	Contact material	AgNi 90/10
<b>Voltage (both ranges within one unit on different terminals. <math>M\Delta</math></b>		Load (GP)	10.00 Aac@250 Vac
100 Vac [1] Rated (Vrms)	69/120 Vac	Discrete output Group B [R 6-9]	isolated
Max. value (Vmax)	86/150 Vac	Contact material	AgNi 90/10
Rated (Vphase-ground)	150 Vac	Load (GP)	10.00 Aac@250 Vac
Rated surge volt (Vsurge)	2.5 kV	RS-485 interface	isolated 500 Vac
400 Vac [4] Rated (Vrated)	277/480 Vac	CAN bus interface	isolated 500 Vac
Max value (Vmax)	346/600 Vac	Housing	Flush - Type easYpack
Rated (Vphase-ground)	300 Vac	Dimensions	Flush -219x171x61mm (8.6x6.7x2.4in.)
Rated surge volt (Vsurge)	4.0 kV	Front cutout	Flush - 186[+1.1]x138[+1.0] mm
Accuracy	Class 1	Material	glass fiber -reinforced plastic
Measurable alternator windings	3p-3w,3p-4w,1p-2w,1p-3w	Connection	screw/plug terminals AWG 14 / 2.5 mm <sup>2</sup>

Setting range - Primary	50 to 650,000 Vac	Front	insulating surface
Linear measuring range	1.25x Vrated	<b>Protection system (with proper installation)</b>	
Measuring frequency	50/60Hz 940 to 70 Hz)	Front	IP54 (with clamp fastening)
input resistance per path	[1] 0.498MΩ [4] 2.0MΩ	Front	IP65(with screw fastening)
Max.power consumption per path	<0.15 W	Back	IP20
Current Rated (Irated)	[1]/1 A or [5] /5 A	Weight	approx. 800 g (1.75 lbs.)
Linear measuring range	I source=3.0x Irated	Disturbance test (CE)	tested acc. To applicable EN guidelines
Burden	<0.15 VA	Listings	UL/cUL listed, Ordinary Locations, File No. 231544
Rated Short-time current (1 s)	[1]50x I rated, [5] 10x Irated		

### 7.2.2. Masterpact ACB NW Circuit Breakers



The Masterpact NW circuit-breaker range features optimized dimensions: not only is it more compact, but even better two sizes are sufficient to cover requirements from 4000 to 6300 A. At a time when installations are becoming increasingly complex, Masterpact NW enables standardization of electrical switchboards by providing unrivalled **simplicity** in terms of both choice and installation.

### 7.2.3. Surgelocic TVSS



With SURGELOGIC TVSS, Square D by Schneider electric offers the world's finest array of Transient Voltage Surge Suppression solutions for electrical distribution systems. From simple to mission-critical applications in commercial and industrial construction and OEM design, the comprehensive SURGELOGIC TVSS line provides a Surge Protective Device (SPD) for every need.



### 7.3. Cooling



Uniflair wall mounted cooling units to be installed on the external wall of the enclosure. The built-in air condenser means that the units can be supplied **completely assembled and filled with refrigerant** the components are set in the factory for normal working conditions and the electrical and cooling functions are all tested. Installation only requires simple electrical wiring and mechanical fixing to the shelter. The direct **free-cooling units (WMF)** are supplied with a motorized damper: during free-cooling the excess of air is expelled from the room through the condenser section without using any extra over-pressure dampers.

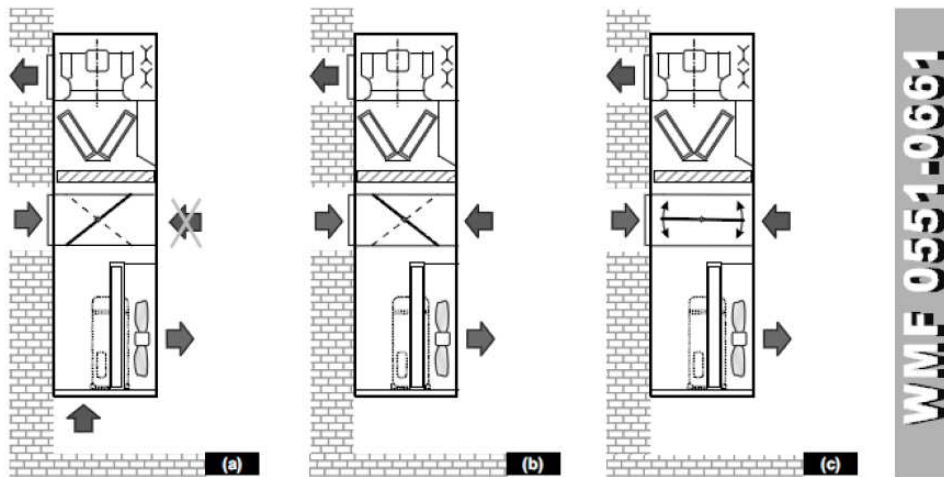

Mechanical  
Cooling

Free-cooling  
Mode

Free-cooling  
+ Mixing

## 7.1. HVAC – Fresh Air Ventilation System - ERV

- TwinFresh Comfo RA-50-2, single-room ventilator is an easy and effective solution for arranging of decentralized energy saving ventilation in separate rooms. The ventilator is equipped with a ceramic regenerator that enables supply of fresh air due to extract air heat energy regeneration.
- The ventilator is designed for through-the-wall mounting. The telescopic ventilator design enables its installation in the walls from 250 mm (9 13/16") up to 470 mm (18 1/2") thick for the ventilator TwinFresh Comfo RA-50 and from 120 mm (4 3/4") up to 300 mm (11 13/16") thick for the ventilator TwinFresh Comfo RA-50-2.
- The ventilator is rated for continuous operation always connected to power mains.
- The ventilator is designed for indoor application with the ambient temperature ranging from -20°C (-4 °F) up to +50°C (+122 °F) and relative humidity up to 80%.
- The ventilator is classified as a class I electric appliance.
- Ingress Protection (IP) rating from solid objects and liquids IP 24.



Ventilator Technical Specifications			
Speed	I	II	III
Supply Voltage, 50-60Hz (V)	1 Phase 100-230V		
Max. Total Power (W)	3,80	3.96	5,61
Max. Ventilator Current (A)	0,024	0,026	0,039
Max. Air Capacity(m <sup>2</sup> /H) (CFM)	14 (8,2)	28(16,5)	54 (31,8)
RPM (min)	610	800	1450
Noise Level, 3 m [dB(A)] (Sones)	19 (0,3)	22 (0,5)	29 (0,81)
Max. Transported Air Temperature [°C] / (°F)	-20 (-4) up to +50 C (+122)		
Heat Regeneration Efficiency	up to 91%		

Regenerator Type	<b>Ceramic</b>
------------------	----------------

## 8. Exclusions

The following list gives the limit of our scope of supply. All works listed hereafter are excluded from this proposal.

### General:

- Any item not specifically listed in the proposal
- Freight to the final site
- Unloading of the module into its final position
- Project management services

### Civil works:

- Any outdoor and indoor civil works (e.g. trenches, preparation of foundations, concrete slabs, fireproof walls, doors, holes, stairs...)
- Any opening or drilling in the building existing walls and roof
- Any scaffolding, builders work or allied tradesman work
- Any ceiling or overhead plenum
- Installation of condensers on external slab
- Attachment of piping between condensers and module

### Data cabling:

- Any IT cabling and fiber optics installation

### Electrical cabling:

- Any electrical installation work outside the prefabricated solution.
- Any digging, trenches and soil preparation for fuel tank and piping network installation
- The supply and installation of the incoming LV electrical supply from the Gensets
- The supply and installation of the incoming LV electrical supply from the normal source

### Electrical equipment:

- Emergency gensets including fuel tanks
- Lightning Protection

## **9. Pricing**

### **Total Solution Price**

Our quotation is open for acceptance for a period of 90 days from the date of this document.

### **Basis of the Schneider Electric IT Corporation Offer**

This document will define the proposed scope of work and associated commercial details for the solution designed by Schneider Electric IT Corporation representative. Offer has been submitted on the basis of the interaction that has taken place between Schneider Electric IT Corporation and the customer.

.