

# Transparent Ready® Products

## Web-enabled Power and Control

*Navigate* freely across a universal network

Catalog  
June

# 06

Transparent  
*Ready*®  
*Web-enabled Power & Control*



a brand of  
**Schneider**  
Electric



**Telemecanique**

For .....

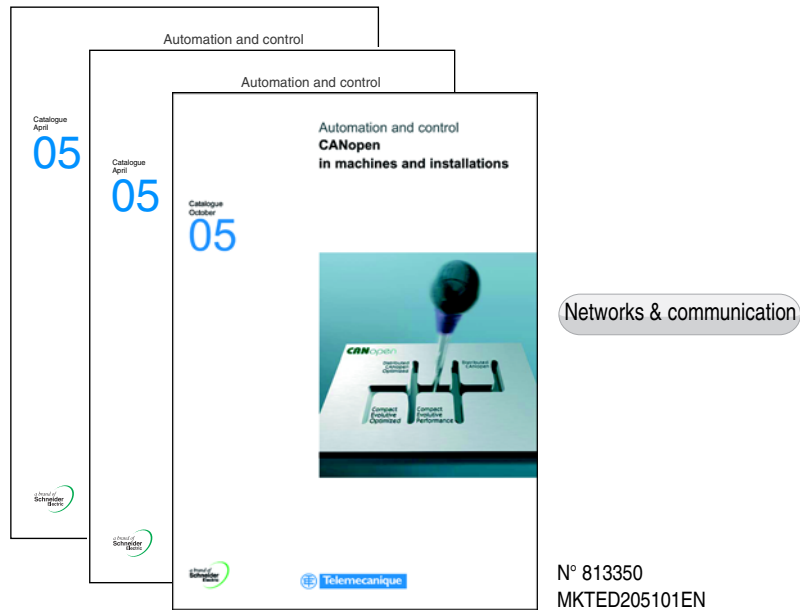

## Automation



**Global Detection**  
Electronic and electromechanical sensors  
N° 54752 - MKTED203031EN

Limit switches  
Proximity sensors  
Photo-electric and ultrasonic sensors  
Pressure switches  
Rotary encoders

**Software**  
Safety mat configuration software



**Modicon® Momentum™**  
distributed I/O and control  
N° 807861 - MKTED205061EN



**Modicon Quantum™**  
**Automation platform, Unity™ Software and Concept Proworx® software**  
N° 802621 - MKTED204071EN



**Modicon Premium™**  
**Automation platform and Unity™ - PL7 software**  
N° 802625 - MKTED204072EN



**Automation platform**  
**Modicon TSX Micro and PL7 software**  
N° 70984 - MKTED204012EN

PLCs, PC based control  
Distributed I/O  
Communication



**Automation and relay functions**  
N° 70455 - MKTED204011EN

Plug-in relays  
Electronic timers  
Control relays  
Counters  
Smart relays

**Software**  
PLCs and safety controllers programming software



**Control and signalling components**  
N° 805911 - MKTED205021EN

Control and signalling units  
Cam switches  
Beacons and indicator banks  
Control and pendant stations  
Controllers  
Front panels, mounting kits  
Emergency stops  
Foot switches



**Human/Machine interfaces**  
N° 96949 - MKTED2040401EN

Operator interface terminals, industrial PCs, Web servers, HMI and SCADA PC-based software

**Software**  
Operator terminal software



**Motor starter solutions**  
**Control and protection components**  
N° 27501 - MKTED201001EN

Contactors  
Circuit-breakers, fuse carriers  
Thermal relays  
Combinations, motor controllers

Mounting solutions  
Motor starter mounting kits



**Soft starters and variable speed drives**  
N° 802660 - MKTED204091EN

Software,  
Variable speed drives

**Software**  
Motor control programming software

..... all Automation & Control functions

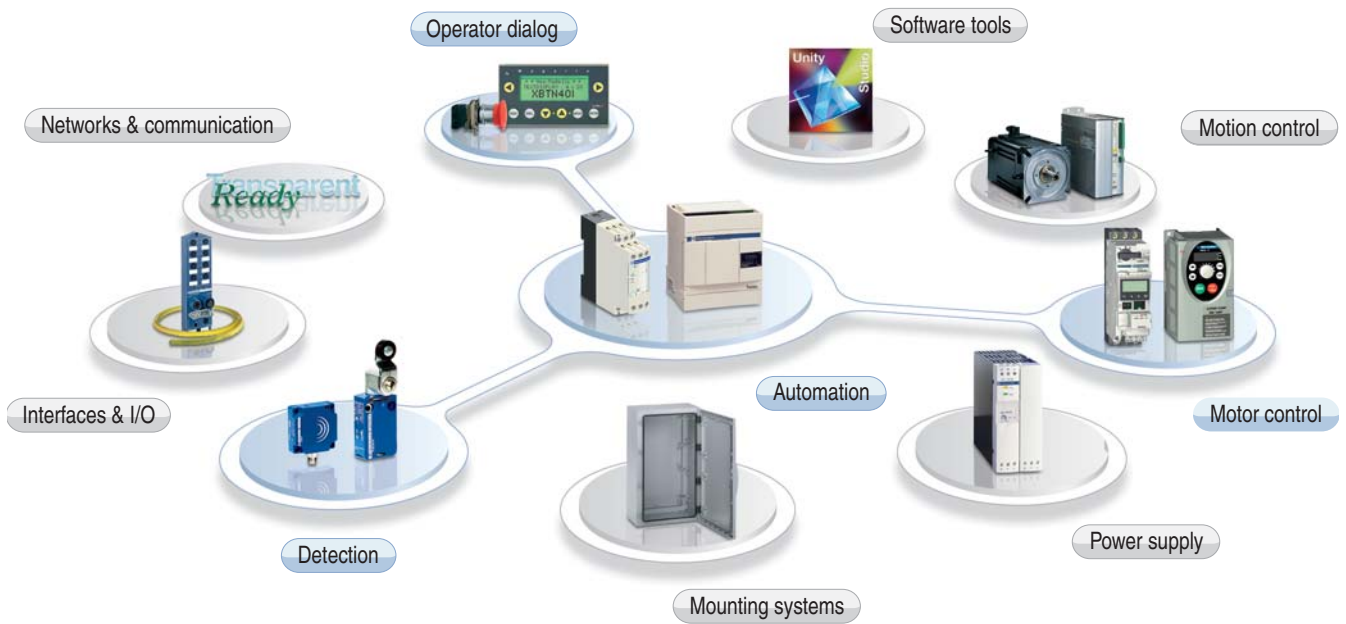

Motion control	Machine safety	Interfaces & I/O	AS-Interface	Networks & communication
<p> <b>Lexium® 17D Motion control</b> N° 806381 - MKTED205031EN</p> <p> <b>Twin Line™ Motion control</b> N° 061233 - DIA7ED2030902EN</p> <p>Servo drives and brushless motors Motion control modules Modicon Premium and Modicon Quantum</p> <p><b>Software</b> Software for drives and motors</p>	<p>This catalog contains Automation and Control function products relating to Safety</p> <p> <b>Preventa™ Safety solutions</b> N° 67341 - MKTED203111EN</p> <p>Safety monitors and controllers on AS-Interface Switches, light curtains, mats</p> <p>Emergency stops, control stations, enabling switches, foot switches, beacons &amp; indicator banks</p> <p>Optimum and universal controllers</p> <p>Switch disconnectors, thermal-magnetic motor circuit breakers, enclosed D.O.L. starters</p>	<p> <b>Interfaces, I/O splitter boxes and power supplies</b> N° 70263 - MKTED203113EN</p> <p>Plug-in relays Analog converters Discrete interfaces Pre-wired interfaces IP67 Splitter boxes</p> <p>Connectors Cable ends, terminal blocks</p> <p> <b>Advantys™ STB - IP 20 distributed inputs/outputs</b> N° 804818 - MKTED204101EN</p> <p>Modules for automation island Network interface, power distribution, digital I/O, analogs and application-specific software</p> <p><b>Software</b> Software to design and install AS-Interface system, safety monitors and controllers on AS-Interface programming software</p> <p>STB configuration software</p>	<p>This catalog contains Automation and Control function products relating to the AS-Interface cabling system</p> <p> <b>AS-Interface cabling system</b> N° 804961 - MKTED204121EN</p> <p>IP20/IP67 interfaces, cables, repeaters, addressing and adjustment terminals</p> <p>Control stations, keypads, beacons &amp; indicator banks</p> <p>Master modules for PLCs</p> <p>AS-Interface power supplies</p> <p>Motor controllers, enclosures, variable speed drives</p>	<p> <b>Ethernet TCP/IP and Web technologies</b> <b>Transparent Ready® Web-enabled Power and Control</b> N° 809201 - MKTED205102EN</p> <p>Embedded Web services Ethernet communication services Connecting Ethernet devices Transparent Ready partners</p> <p> <b>CANopen in machines &amp; installations</b> N° 813350 - MKTED205101EN</p> <p>CANopen implementations Telemecanique devices Infrastructure, wiring system CANopen partners</p>
<p><b>Power supplies</b></p> <p> <b>Interfaces, I/O splitter boxes and power supplies</b> N° 70263 - MKTED203113EN</p> <p>Switch mode power supplies</p> <p>Filtered rectified power supplies and transformers</p>				

# Transparent Ready® Products

## Web-enabled Power and Control

---

<b>1 – Presentation</b>	
Introduction . . . . .	page 8 - 10
Service classes offered . . . . .	page 11 - 13
<i>Panorama of Transparent Ready products . . . . .</i>	<i>page 14 - 17</i>
<b>2 – System approach</b>	
<i>Contents . . . . .</i>	<i>page 18 &amp; 19</i>
FactoryCast™ Embedded Web services . . . . .	page 20
Ethernet TCP/IP communication services . . . . .	page 21
Performances of Ethernet TCP/IP network . . . . .	page 46 - 53
Industrial Ethernet cabling system . . . . .	page 54
<b>Application to specific domains</b>	
Application to electrical distribution . . . . .	page 60
Application to Intelligent Motor Control Center (iMCC) . . . . .	page 62
Modicon Quantum™ Hot Standby . . . . .	page 64
Application to Preventa™ safety PLCs . . . . .	page 66
Unity™ Studio software suite . . . . .	page 67
Integration of Transparent Ready products . . . . .	page 68 - 76
<b>3 – Field devices</b>	
<i>Contents . . . . .</i>	<i>page 77</i>
Modicon Momentum™ distributed I/O . . . . .	page 78
Advantys™ STB & OTB distributed I/O . . . . .	page 79 - 80
Lexium® 17D servo drives for brushless motors . . . . .	page 81
Altivar™ 61/71 variable speed drives . . . . .	page 82 - 83
Identification systems Inductel™ & Ositrack™ . . . . .	page 84
<b>4 – Ethernet gateway products</b>	
<i>Contents . . . . .</i>	<i>page 87</i>
Ethernet/Modbus™ gateway . . . . .	page 88
FactoryCast™ Web gateway . . . . .	page 89
Ethernet/Modbus Plus gateway/router . . . . .	page 90
<b>5 – Electrical Distribution products</b>	
<i>Contents . . . . .</i>	<i>page 91</i>
<b>MV / LV protection &amp; metering and</b>	
iMCC motors control-command . . . . .	page 92 - 93
Advanced electrical circuit monitors . . . . .	page 94
Electrical power management software . . . . .	page 95

---

## 6 – Controllers and PLCs

<b>Contents</b> .....	<b>page 96</b>
<b>Modicon® Momentum™ M1E processor adapters</b> .....	<b>page 97</b>
<b>Twido™ compact base controller</b> .....	<b>page 98</b>
<b>TwidoPort™ interface for Twido controllers</b> .....	<b>page 99</b>
<b>Modicon™ TSX Micro platform</b> .....	<b>page 100</b>
<b>Modicon Premium™ Atrium platform</b> .....	<b>page 101 - 103</b>
<b>Modicon Quantum™ platform</b> .....	<b>page 104 - 105</b>
<b>Preventa™ safety PLCs</b> .....	<b>page 106 - 107</b>
<b>W@de remote terminal units for the water sector</b> .....	<b>page 108</b>

## 7 – Human/Machine Interface products

<b>Contents</b> .....	<b>page 111</b>
<b>Magelis® XBT graphic terminals</b> .....	<b>page 112</b>
<b>Magelis® iPC industrial PCs</b> .....	<b>page 113 - 114</b>
<b>Web application development, FactoryCast™ HMI software</b> .....	<b>page 115</b>
<b>Vijeo™ Look supervisory software</b> .....	<b>page 116</b>
<b>Monitor Pro™ supervisory software</b> .....	<b>page 117</b>
<b>OFS data server software</b> .....	<b>page 118</b>

## 8 – Cabling system

<b>Contents</b> .....	<b>page 119</b>
<b>ConneXium™ hubs</b> .....	<b>page 120</b>
<b>ConneXium™ transceivers</b> .....	<b>page 121</b>
<b>ConneXium™ switches</b> .....	<b>page 122 - 123</b>
<b>ConneXium™ connection cables</b> .....	<b>page 124</b>

## 9 – Modbus™-IDA organization and Collaborative Automation Partner Program

<b>Contents</b> .....	<b>page 126</b>
<b>Modbus-IDA organization</b> .....	<b>page 127</b>
<b>Collaborative Automation Partner Program</b> .....	<b>page 128</b>
<b>Transparent Ready® Partners</b> .....	<b>page 129</b>
<b>Index</b> .....	<b>page 149</b>



---

## 1 - Presentation

- Introduction ..... page 8 -10
- Service classes offered ..... page 11 - 13
- Panorama of Transparent Ready® products (field devices, gateways, electrical distribution products, controllers and PLC, terminals) . page 14 - 15***
- Selection guide of Ethernet gateways ..... page 16***
- Selection guide of HMI products ..... page 16***
- Selection guide of ConneXium™ cabling system ..... page 17***

# Transparent Ready® Products

Universal technologies for a world without restrictions

## Presentation

### Transparent Ready products making collaborative architectures a reality

Company environments are constantly changing due to the pressure of competition and the need for profitability. It is vital to take opportunities quickly. The challenge of today's world is therefore agility, which means adopting a **collaborative approach** to share data in real-time.

Schneider Electric's Transparent Ready products, based on universal Ethernet TCP/IP and Web technologies, meet this requirement. Telemecanique® industrial automation products and Merlin Gerin® electrical distribution products can be integrated into real-time data-sharing systems, with no need for interfaces.

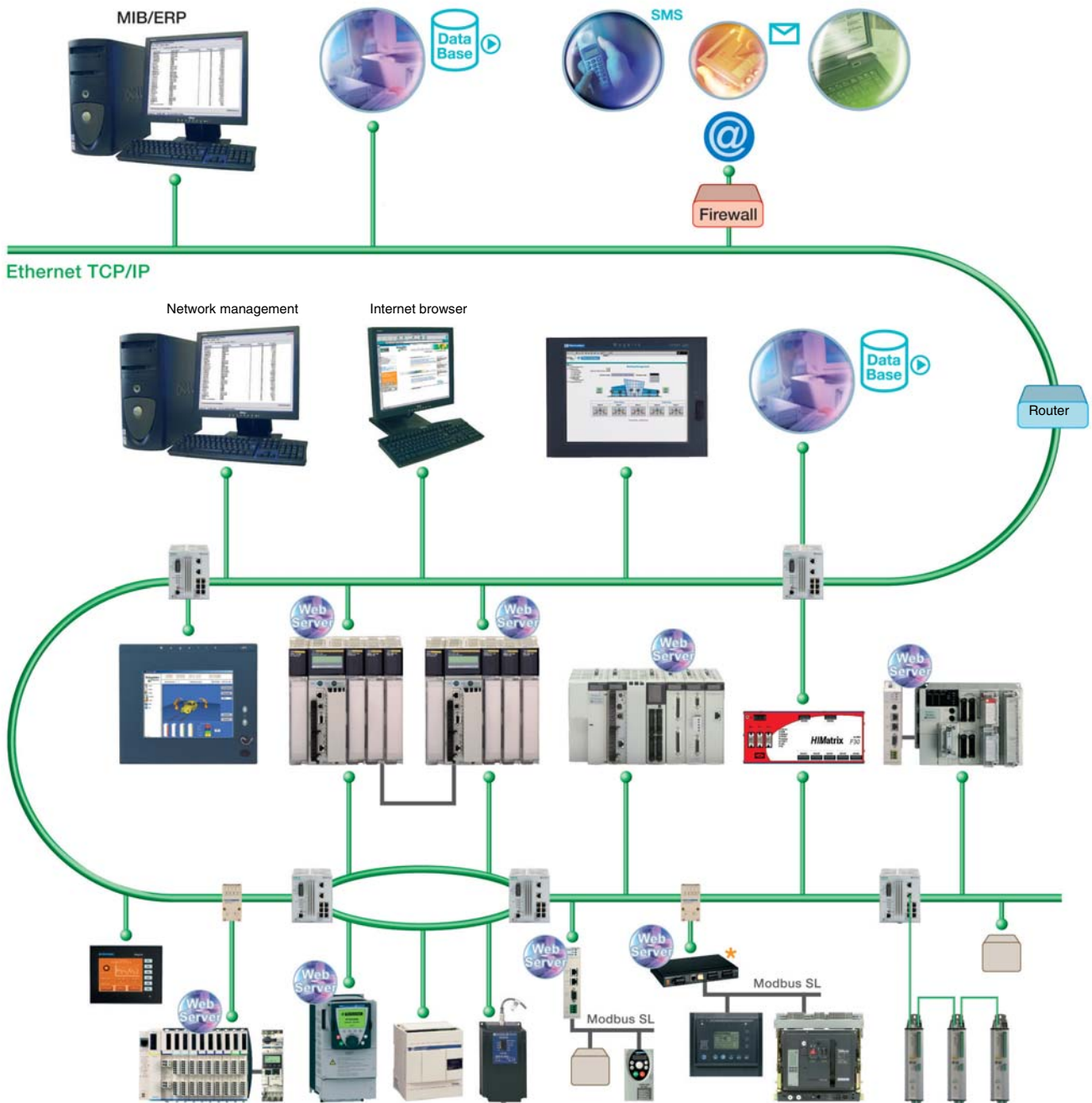



# Transparent Ready® Products

## Universal technologies for a world without restrictions

### Presentation (continued)

#### The universal communication standard: Ethernet TCP/IP

The recognition of Ethernet TCP/IP, both in organizations and on the Internet, has made it the **communication standard** of today. Its wide use is leading to a reduction in connection costs, increased performance and the addition of new functions, which all combine to ensure its durability.

Ethernet TCP/IP meets the connection requirements of every application:

- Twisted pair copper cables for simplicity and low cost.
- Optical fiber for immunity to interference and for long distances.
- Communication redundancy, inherent in the IP (*Internet Protocol*).
- Radio or satellite to overcome wiring restrictions.
- Remote point-to-point access via the telephone network or the Internet for the cost of a local call.

Ethernet TCP/IP, a truly open technology, supports all types of communication:

- Web pages.
- File transfer.
- Industrial messaging, etc.

With its high speed, the network no longer limits the performance of the application. The architecture can evolve without any difficulty. The products or devices remain compatible, ensuring the long-term durability of the system.

#### Modbus® protocol messaging: a standard technology adapted for the world of automation and electrical distribution

Modbus serial link protocols have been the de facto standard in the industry since 1979. It is used for the communication of millions of automation devices. As a result of this success, the Internet community has reserved the TCP 502 port for Modbus protocol messaging. Modbus protocols are recognized by international standard IEC 61158 and is a "Chinese National Standard".

Modbus messaging can thus be used for exchanging automation data on both Ethernet TCP/IP and the Internet, as well as for all other applications (file exchange, Web pages, E-mail, etc).

The simple structure of Modbus serial link protocols are bringing it ever-increasing success. Users can download the specifications and source code for numerous devices that use the Modbus TCP/IP protocol, free of charge from the Modbus-IDA website: [www.modbus-ida.org](http://www.modbus-ida.org)

Building on its industrial expertise, Schneider Electric now has a complete offer of highly user-friendly services on Ethernet TCP/IP that are dedicated to the world of automation: Modbus TCP/IP messaging, optimized I/O Scanning, publication and subscription of variables between Controllers and PLCs (Global Data), automatic device reconfiguration (Faulty Device Replacement), bandwidth monitoring, system diagnostics (Web diagnostic), SOAP/XML Web services, etc.

The single network, requiring no interfaces between the worlds of information technology and automation, is now a reality.

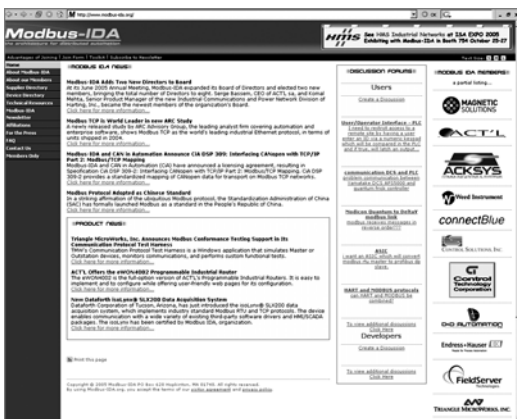

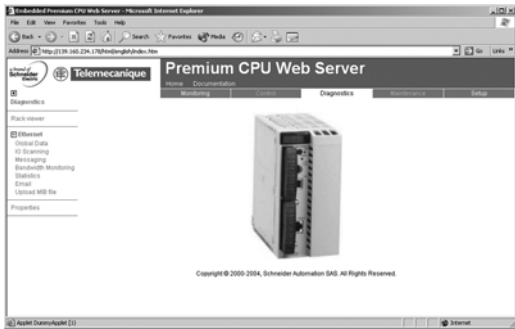

## Presentation (continued)

### Free navigation on the Web Automation

In 1998, Schneider Electric broke new ground with the first on market Web servers embedded in Telemecanique PLCs.

With continuous innovations, Schneider Electric is spreading the use of Web technologies in industrial equipment by implementing Web servers inside new Telemecanique and Merlin Gerin devices such as PLCs and controllers, distributed I/Os, variable speed drives, power meters, etc.

These web servers represent the easiest solution to get remote and transparent access to equipment information and device diagnostics, simply using an Internet browser.

With FactoryCast HMI, Schneider Electric is taking an important step further, by making the Web Servers "Active", thus holding your HMI application as a Web server.

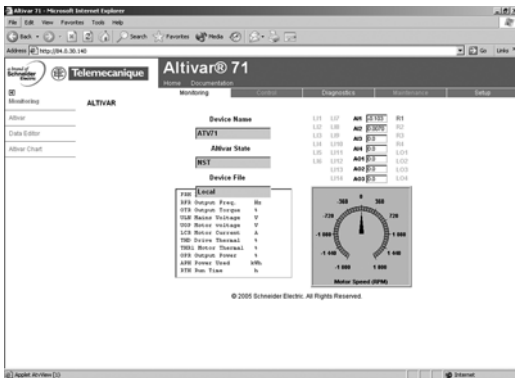

Not only does these active server provide Web pages displaying system and process information, but they also execute HMI functions at source in the PLC and controller device, totally autonomously, without making use of the controller processor: management of a real-time HMI database with data processing, E-mail transmission, direct connectivity with relational databases, etc.

With its functions embedded in a controller, the FactoryCast HMI active Web server:

- Simplifies or removes the need for conventional HMI/SCADA (*Supervision Control And Data Acquisition*) solutions, reducing communication via polling to update HMI/SCADA databases
- Provides multiclient remote control, without any special software on the client stations
- Provides a direct link to company information systems, without the need for any intermediary interface.

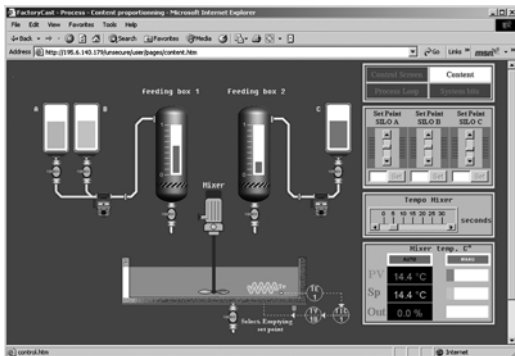

## Transparent Ready Products for a world without restrictions

Schneider Electric has a wide range of Transparent Ready products: Controllers and PLCs, industrial PCs, HMI devices, variable speed drives, I/O modules, safety PLCs, gateways, servers, switches, SCADA software, inductive identification systems, etc.

These products provide different levels of Web services and communication services on Ethernet TCP/IP, according to users' requirements. In order to simplify choice and ensure their interoperability within a system, each Transparent Ready product is now identified by the class of services it provides.

### With Transparent Ready Products, you have ...

- **Ingenuity** of collaboration improving agility
  - Transparency of information throughout the enterprise, make authorized people and tools, better share data.
- **Openness** of universal standards Ethernet TCP/IP with Modbus
  - Vendor independent and well known, so future proof and open
  - Only one communication technology to maintain
  - Seamless vertical & remote connections, enabling collaboration.
- **Simplicity** of Web technologies optimizing your Human Machine Interface
  - Easy and inexpensive local & remote access from a web browser (e.g. for maintenance)
  - Distribute Web servers on automation devices and remove bottlenecks
  - Combine Web technologies and traditional SCADA, to refocus process controls.

### Transparent Ready Products

Ethernet TCP/IP technologies and services      Web technologies and services

### Presentation

The Transparent Ready service classes make it possible to identify the services provided by each device:

- Diagnostic, display and control services via Web technologies
- Ethernet communication services.

The Transparent Ready service classes thus simplify the choice of devices and ensure their interoperability within an architecture.

### Web service classes

The Web services are defined by 4 classes identified by a letter:

- Class **A**: No Web service
- Class **B**: Standard Web service
- Class **C**: Configurable Web service
- Class **D**: Active Web service.

Transparent Ready devices with an embedded Web server can provide 3 types of Web service:

- Maintenance Web services control Web services
- Diagnostic Web services
- Optional Web services such as documentation or configuration.

The following table specifies the services provided by each Web service class (A, B, C or D).

Web service class		Web services			
		Maintenance	Monitoring and IT link	Diagnostics	Optional
<b>D</b>	Active Web server	- User website update	- Autonomous execution of specific services (e.g. alarm notification by E-mail, exchange with databases, calculations, ...) - SOAP/XML (client/server)	- User-defined states	- User documentation
<b>C</b>	Configurable Web server		- PLC variables editor - Remote commands - User Web pages - SOAP/XML (server)	- Communication service diagnostics - State of internal device resources	
<b>B</b>	Standard Web server	- Remote device software update - Remote auto-tests	- Device description - Data viewer	- Device status - Device diagnostic	- Configuration of network parameters and Ethernet communication services - Device documentation
<b>A</b>	No Web server	- No Web service			

### Ethernet communication service classes

The Ethernet communication services provided by a device are defined by 3 classes, identified by a number:

- Class 10: standard Ethernet communication services
- Class 20: Ethernet communication management services (network level and device level)
- Class 30: advanced Ethernet communication services.

Transparent Ready devices can provide eight types of Ethernet communication service:

- Modbus TCP/IP messaging service
- I/O Scanning service
- FDR (*Faulty Device Replacement*) service
- SNMP network management service
- Global Data service
- Bandwidth management service
- NTP time synchronization service
- SMTP event notification service (E-mail).

These Ethernet communication services are described in chapter 2, "System approach", see pages 34 to 45.

The following table specifies the services provided for each Ethernet communication service class.

Ethernet communication service classes		Ethernet communication services							
		Modbus messaging	I/O Scanning	FDR	Network management SNMP	Global Data	E-mail SMTP	Bandwidth management	Time synchronization NTP
30	Advanced services	- Direct reading/writing of I/O	- Periodic reading/writing of I/O  - Configuration of the list of devices scanned	- Automatic control and updating of the device parameters configuration	- Use of the MIB library by an SNMP manager	- Publication and subscription of network variables	- Notification of events by E-mail	- Monitoring of load level	- Synchronization of device clocks
	20			Communication management services	- Automatic assignment of the IP address and network parameters - Control and updating of the configuration and device parameters by the user				
10	Standard services	- Reading/writing of data words		- Local assignment of the IP address Verification of duplicate IP addresses					

### Choice of Transparent Ready devices

The services provided by a Transparent Ready device are identified by a letter defining the level of Web service, followed by a number defining the level of Ethernet communication service. For example:

- A class **A10** product is a device with no Web service and standard Ethernet services
- A class **C30** product is a device with a configurable Web server and advanced Ethernet communication services.

**The services provided by a higher class include all the services supported by a lower class.**

Transparent Ready devices are chosen from 4 main families:

- Sensor and preactuator type field devices (simple or intelligent)
- Controllers and PLCs
- Human Machine Interface (HMI) applications
- Dedicated gateways and servers.

The selection table on the following pages can be used for choosing Transparent Ready devices according to the required service classes.

		Web services			
		Class A	Class B	Class C	Class D
Ethernet communication services		No service	Standard	Configurable	Active
Class 30	Advanced service				
Class 20	Communication management services				
Class 10	Standard services				

		Class A	Class B	Class C	Class D
Class 30			B30		
Class 20			B20	C20	
Class 10		A10	B10		D10

Simple and intelligent devices (A10, B10)

Controllers and PLCs (B20, C20)

### Ethernet TCP/IP communication services

### Web services

### No Web service Class A

No Web service

### Advanced services Class 30

- FDR (faulty device replacement), automatic checking of network parameters
- SNMP (network administration), use of the MIB library by an SNMP tool
- Global Data
- Bandwidth management
- NTP (clock synchronization)
- SMTP (notification by E-mail)



### Communication management services Class 20

- Modbus TCP/IP messaging (read/write I/O)
- I/O Scanning
- FDR (faulty device replacement), automatic assignment of network parameters
- SNMP (network administration), product detection



### Standard communication services Class 10

- Modbus TCP/IP messaging
- FDR (faulty device replacement), verification of duplicate IP address



- Momentum adapter 170 ENT 110 02
- Advantys OTB interface OTB 1E0 DM9LP
- Ositrack identification system XGK Z33ETH
- Twido compact base TWD LCAE 40DRF
- TwidoPort interface 499 TWD 01100
- Atrium coprocessor TSX PCI 57 204/454M
- Preventa safety compact PLC XPS MF 30/31/35
- Preventa safety modular PLC XPS MF 60
- Modbus gateway 174 CEV 300 20
- Modbus Plus gateway 174 CEV 200 40
- Magelis graphic terminal XBT G/XBT GT
- Magelis graphic terminal XBT F024/034
- Magelis Smart & Compact iPC MPC ST5/KT5
- Magelis Modular iPC MPC AN0/BN0/CN0

See page

**Standard Web services  
Class B**

- View device description and status
- Remote software update

**Configurable Web services  
Class C**

- Variables editor
- Remote commands
- User Web pages
- Communication service diagnostics
- SOAP/XML server

**Active Web services  
Class D**

- Autonomous execution of services
- Diagnostics of user-defined states
- Alarm notification by E-mail
- Databases access
- SOAP/XML client/server

Premium module TSX ETY 4103	Premium FactoryCast module TSX ETY 5103		103
Premium processor TSX P57 1634M Premium processor TSX P57 2623/34M Premium processor TSX P57 2823 Premium processor TSX P57 3623/34M Premium processor TSX P57 4823 Premium processor TSX P57 4634/5634M			101
Quantum module 140 NOE 771 01	Quantum FactoryCast module 140 NOE 771 11		105
Quantum processor 140 CPU 65150 Quantum processor 140 CPU 65160			104
TSX Micro module TSX ETZ 410	TSX Micro FactoryCast module TSX ETZ 510		100
Momentum adapter 170 ENT 110 01			78
Advantys STB module STB NIP 2212			82 & 83
	Altivar 71/61 communication card VW3 A3 310		81
	Modbus FactoryCast Gateway TSX ETG 1000		89
	Uni-Telway FactoryCast Gateway TSX ETG 1010		89
	Premium FactoryCast module TSX ETY 110 WS	Premium FactoryCast HMI TSX WMY 100	103
		Quantum FactoryCast HMI 140 NWM 100 00	105
		W@de remote terminal unit for water W330	108
			78
			80
			85
			98
			99
			102
			106
			107
			90
			90
			112
			112
			113
			114
Inductel identification station XGK S1715503			84
Lexium 17D communication card AM0 ETH 00● V000			83
Modbus gateway EGX 100MG (1)			92
Modbus gateway TSX ETG 100			88
Momentum M1E 171 CCC 980 ●0 Momentum M1E 171 CCC 960 ●0			97
W@de remote terminal unit for water W315/W320			108
	Modbus server EGX 400MG (1)		93
	Circuit Monitor card ECC 21		94

(1) Dedicated to Sepam protection relays, to Micrologic protection units for Masterpact circuit-breakers, to POWERLOGIC® PM and CM power meters.

# Transparent Ready® Products

Ethernet gateways of Schneider Electric

Human-Machine Interface products

ConneXium cabling system

## Gateways

## Converter



<b>Transparent Ready class</b>	A10	B20	C20	C10
<b>Dedicated to</b>	Twido controller	TSX Micro automation platform		CM 3000/4000 circuit monitor
<b>Communication type</b>	Many-to-one Modbus serial link	Many-to-one terminal port (Uni-TE)		Many-to-one Modbus serial link
<b>Embedded</b>				
Web server	–	Standard	FactoryCast configurable	WPG type
Remote access	–	Remote Access Server (RAS)		–
<b>Type of gateway</b>	499 TWD 01100	TSX ETZ 410	TSX ETZ 510	ECC21
<b>Page</b>	99	100		94

## Human-Machine Interface products

<b>Graphic terminals</b>	<b>Industrial PCs</b>	<b>Web HMI application development software</b>	<b>SCADA supervisory software</b>
--------------------------	-----------------------	---	-----------------------------------



<b>Transparent Ready class</b>	A10			
<b>Display</b>	3.8", 5.7", 7.4", 10.4", 12.1"	12", 15"		
<b>Type of HMI products</b>	Magelis XBT G/GT Magelis XBT F	Magelis iPC	FactoryCast HMI	Vijeo Look Monitor Pro OFS
<b>Pages</b>	112	113 and 114	115	116 to 118



## Router



## Server



B10				C20			D10
Automation and control	Automation and control	Electrical distribution (high temperature range)	Remote terminal unit for water domain application	Automation and control	Electrical distribution	Remote terminal unit for water domain application	
Many-to-many Modbus Plus network	Many-to-many Modbus serial link	PowerLogic® - RNIM (SyMax)	Many-to-many Modbus serial link	Many-to-many Uni-Telway serial link	Many-to-many Modbus serial link	Many-to-many Modbus serial link Uni-Telway serial link	
-	-	-	Standard	FactoryCast configurable	WPG type	Configurable	
-	-	-	GSM/GPRS, PSTN, Leased Line or radio modem	Remote Access Server	-	GSM/GPRS, PSTN, Leased Line or radio modem	
<b>174 CEV 200 40</b>	<b>TSX ETG 100</b> <b>174 CEV 300 20</b>	<b>EGX 100MG</b>	<b>TSX ETW 315 ▲</b> <b>TSX ETW 320 ▲</b>	<b>TSX ETG 1010</b>	<b>TSX ETG 1000</b>	<b>EGX 400MG</b> <b>TSX ETW 330</b>	
90	88, 90	92	109	89	93	108	

▲ Available later

## ConneXium cabling system

Hubs	Transceivers	Switches
		IP 20/IP 30
		IP 67



Type of ports	Copper cable and/or optical fiber	Copper cable		
Selection guidelines	See page 120 to 125			
Type	<b>499 NEH/NOH</b>	<b>499 NTR</b>	<b>499 NES/NOS/NMS/NSS</b>	<b>TCS ESU</b>
Pages	120	121	122 and 123	124

---

## 2.1 Embedded Web services

- FactoryCast™ overview ..... page 20 - 21
- Standard Web services ..... page 22 - 23
- FactoryCast™ configurable Web services ..... page 24 - 25
- FactoryCast™ HMI active Web services ..... page 26 - 29
- FactoryCast™ Gateways Web services ..... page 30 - 31
- SOAP™/XML Web services ..... page 32 - 33

## 2.2 Ethernet TCP/IP communication services

- Standard Ethernet services ..... page 34 - 36
- Modbus™ communication standard ..... page 37
- I/O Scanning service ..... page 38
- FDR replacement service for faulty devices ..... page 39
- Global Data service in real time between stations ..... page 40
- NTP time synchronization service ..... page 41
- SMTP electronic mail notification service ..... page 42
- SNMP network management protocol service ..... page 43
- TCP Open optional service ..... page 44

## 2.3 Performance of Ethernet TCP/IP network

- Guidelines to evaluate the network load ..... page 46 - 49
- Application response time ..... page 50 - 51
- Processing capabilities of Premium™ and Quantum™ PLCs ..... page 52 - 53

## 2.4 Industrial Ethernet cabling system

- Ethernet 802.3 principles ..... page 54
- Different network topologies ..... page 55
- Distance limits and number of devices per segment ..... page 56
- Physical media ..... page 57
- Redundancy ..... page 58
- Guidelines to select cabling industrial devices ..... page 59

---

## 2.5 Application to specific domains

- Electrical distribution ..... page 60 - 61
- Intelligent Motor Control Center (iMCC) ..... page 62 - 63
- Modicon Quantum™ Hot Standby on Ethernet TCP/IP ..... page 64 - 65
- Preventa™ safety PLCs ..... page 66 - 67

## 2.6 Integration of Transparent Ready® products

- Company level ..... page 68
- Inter-PLC level ..... page 69
- Field level
  - Communication with Modbus™ field products ..... page 70
  - Communication with CANopen in machines and installations ..... page 71
  - Communication between field PCs or operator terminals, PLCs and field devices ..... page 71
- Transparent remote communication
  - On the Internet ..... page 72
  - Via telephone networks ..... page 73
  - By radio ..... page 73
- Other requirements (diagnostic, interoperability, security)
  - Diagnostics services ..... page 74
  - Interoperability with third-party products or protocols ..... page 74
  - Ethernet TCP/IP network security ..... page 75

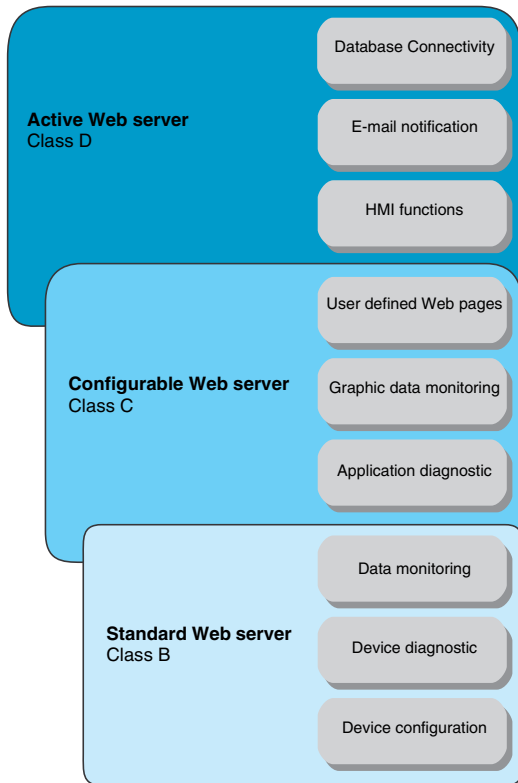

#### Web services overview

Schneider Electric offers a wide range of Transparent Ready products integrating Web services: controllers and PLCs, safety PLCs, industrial PCs, HMI devices (2), variable speed drives, distributed I/O modules, gateways, switches, inductive identification systems, etc.

These products provide different levels of Web services and communication services on Ethernet TCP/IP, according to user requirements.

Among these Transparent Ready products, FactoryCast embedded web services defines a range of modules and gateways with configurable Web server combining:

- Real-time communication functions based on Ethernet TCP/IP
- Predefined Web pages for advanced installation diagnostics
- And the capacity to host dynamic user-defined Web pages or any document (.doc, pdf, etc) designed to assist maintenance.

#### Web services embedded in Ethernet modules and gateways

Transparent Ready Products approach, Ethernet modules and gateways integrate Ethernet TCP/IP services (Modbus TCP/IP messaging, SNMP network management functions, etc).

They also offer, depending on the product, the following Web functions:

- Standard Web services (predefined)
- FactoryCast configurable Web services
- FactoryCast HMI active Web services.

There are two ranges of configurable Web server:

- **FactoryCast modules** with TSX Micro, Premium, Quantum, Momentum automation platforms. These modules provide transparent access to system and application diagnostic information in real-time using Web technologies
- **FactoryCast Gateway** that integrate all the network interfaces, a router RAS function and a customizable Web server in a stand alone unit.

The FactoryCast Gateway is a cost-effective response to the need to integrate serial installations (Modbus or Uni-Telway) in an existing Ethernet TCP/IP infrastructure, as well as requirements for customized remote access services including remote diagnostics, maintenance, monitoring and control using a simple Web browser.

#### Web services presentation

##### Standard Web services

Standard Web services are integrated in the following Schneider Electric Ethernet products: PLC processors and Ethernet modules, distributed I/O modules, variable speed drives, Ethernet gateways. See selection guide page 21.

Using a simple Web browser, the standard Web services provide the following "ready-to-use":

- Device configuration setup
- Remote device diagnostic and maintenance
- Device data monitoring (read/write variables and status).

The embedded Web server is a real-time data server. All the data is presented in the form of standard Web pages in HTML format and can therefore be accessed using any Web browser supporting the embedded JAVA code. The standard functions provided by the Web server are supplied "ready to use" and therefore do not require any programming of either the PLC or device or the client PC supporting the Web browser.

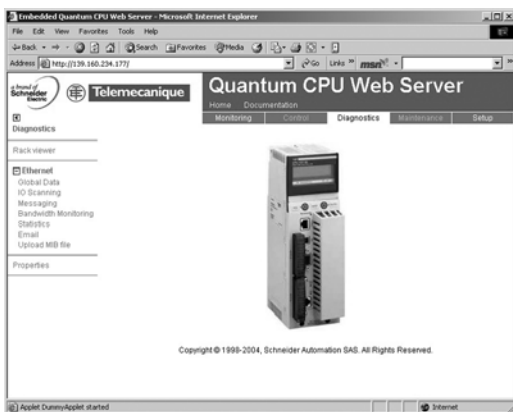

(1) In order to simplify choice and ensure their interoperability within a system, each Transparent Ready product is identified by the class of services it provides. Letter A, B, C or D (level of service for the Web server) followed by 10, 20 or 30 (level of service for Ethernet communication). See pages 11 to 13.

(2) HMI = Human Machine Interface.

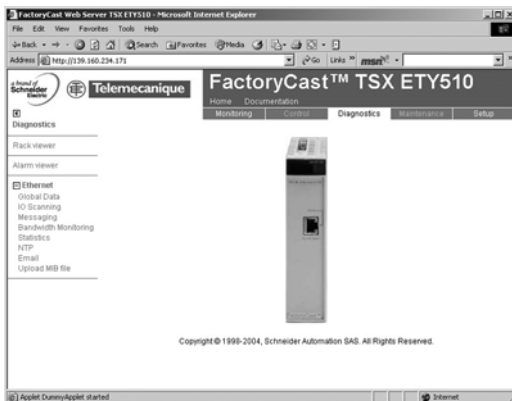

## Presentation of the Web services (continued)

### FactoryCast configurable Web services

FactoryCast configurable Web services are integrated in the following Schneider Electric Ethernet products: TSX Micro, Premium and Quantum FactoryCast PLCs modules and FactoryCast Gateway modules.

In addition to the predefined Web services, the configurable Web server offers the following utilities:

- Graphic application diagnostics (customized graphic views created by the user)
- Graphic monitoring via animated Web pages created by the user and stored in the Web server module.

And depending on the products:

- Management of controllers system and application alarms, with partial or total acknowledgement ("ready-to-use" "Alarm Viewer" pages)
- SOAP/XML server interface (1).

FactoryCast Embedded Web services can also be used to customize supervision, diagnostics and maintenance interfaces via user-defined Web pages or any other document (doc, pdf, etc) transferred to the module.



### FactoryCast HMI active Web services

FactoryCast active Web services are integrated in the Premium and Quantum FactoryCast HMI PLC modules.

The FactoryCast HMI services provide in addition HMI functions, which are executed in the module itself:

- Data acquisition with real-time HMI database management, independent of the PLC processor
- Data processing (arithmetic and logical calculations)
- Direct connectivity with relational databases (traceability, data login)
- Recipe management (read/write)
- Alarm and report notification by E-mail
- Active page server, dynamic generation of animated HTML pages
- SOAP/XML client/server interface(1).

FactoryCast HMI is defined as an active Web server used to execute HMI functions without any effect on the PLC application program and therefore on its scan time.

(1) Standard protocol providing interoperability with computer management applications, see pages 32 and 33.

## Selection of Telemecanique brand Transparent Ready products

Product	Reference	Embedded Web server		
		Standard, class B10/B20	Configurable, class C20/C30	Active, class D10
Modicon Quantum Automation Platform	Processors	140 CPU 651 50/60		
		140 NOE 771 01		
	Modules	140 NOE 771 11	FactoryCast	
		140 NWM 100 00		FactoryCast HMI
Modicon Premium Automation Platform	Processors	TSX P57 2●23 M		
		TSX P57 3623 M		
		TSX P57 4823 M		
		TSX P57 ●634 M		
	Modules	TSX ETY 4103		
		TSX ETY 110WS	FactoryCast	
		TSX ETY 5103	FactoryCast	
		TSX WMY 100		FactoryCast HMI
Modicon TSX Micro Automation Platform	Modules	TSX ETZ 410		
		TSX ETZ 510	FactoryCast	
Modicon Momentum Automation Platform	M1E processors	171 CCC 960 20/30		
		171 CCC 980 20/30		
	Modules	171 ENT 110 01/02		
Advantys STB distributed I/O	Network interface	STB NIP 2212		
Altivar ATV 71/61 variable speed drives	Communication card	VW3 A3 310		
Inductel identification station		XGK S1715503		
FactoryCast Web Gateway		TSX ETG 1000/1010	FactoryCast	
Remote terminal units	W@de	TSX ETW 315/320●1		
		TSX ETW 330●1		

## PLC standard Web services

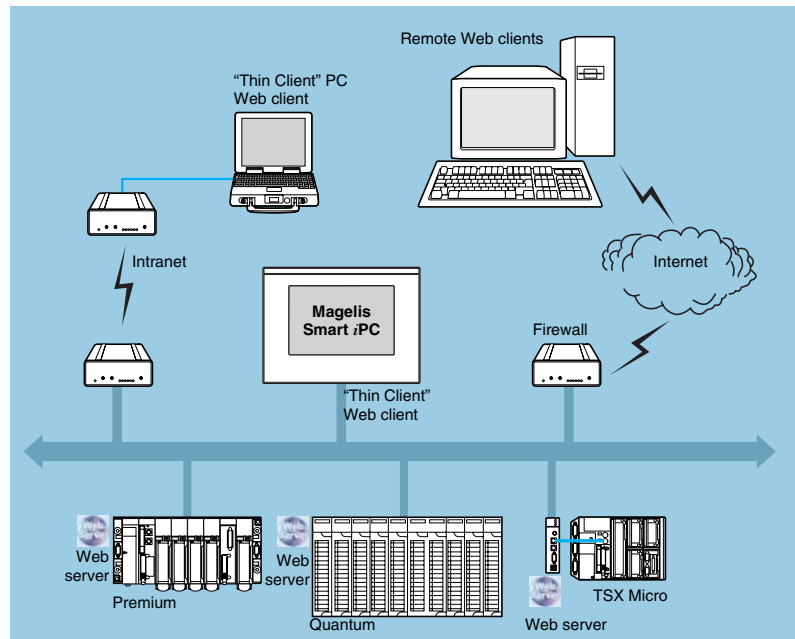

The predefined diagnostic, “PLC rack viewer”, and monitoring, “Data Editor”, functions are supported by the following Modicon PLC automation platforms (1):

- TSX Micro automation platform
- Premium automation platform
- Quantum automaton platform.

See module references on page 21.

These functions can be accessed using a standard Internet browser. They are “ready to use” and secured (password-protected).

They can be used locally or remotely via:

- Intranet
- A modem and RAS server
- Internet.

(1) For standard Web services integrated in the variable speed drives, please consult our catalog “Soft starters and variable speed drives”.

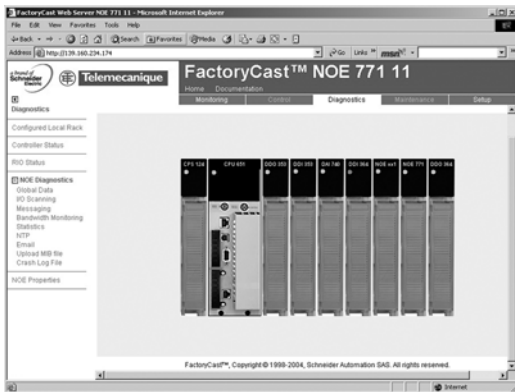

Quantum hardware configuration

## PLC standard Web services (continued)

### PLC diagnostics function “Rack Viewer”

The “Rack Viewer” function (PLC rack display) can be used for PLC system and I/O diagnostics. It displays the following in real-time:

- LED status on the front panel of the PLC
- The PLC version
- The hardware configuration of the PLC including the status of the system bits and words
- Detailed diagnostics of all I/O module channels or application-specific channels in the configuration.

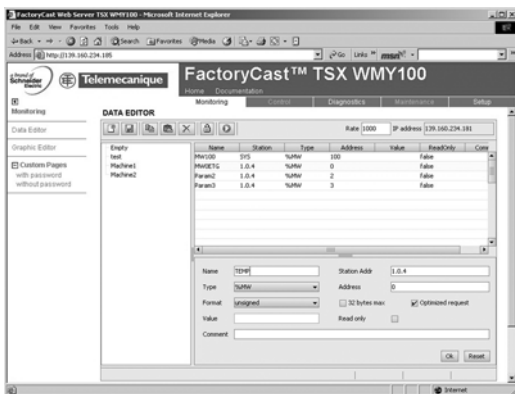

### Data monitoring function “Data Editor”

The “Data Editor” can be used to create animated tables for real-time read/write access to lists of PLC variables.

Various animation tables can be created by the user and saved in the Web server module.

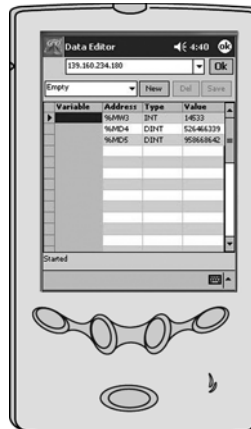

In addition when using FactoryCast Web servers:

- The variables can be entered and displayed by their symbol (S\_Pump 234)
- The write access option can be enabled/disabled for each variable using the Factorycast software. The write access is protected by a dedicated password
- Dedicated data monitoring tool can be use on pocket PC or PDA terminal.

#### FactoryCast configurable PLC Web services

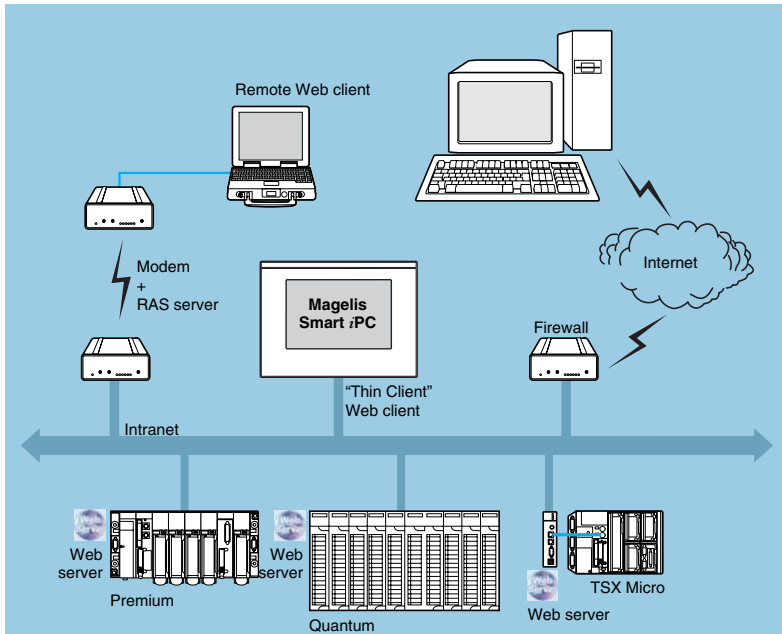

In addition to standard Web services, FactoryCast modules (see selection table on page 21) support the following functions:

- Alarm Viewer
- Creation and display of graphical views via an online graphic editor (Graphic Data Editor integrated)
- Hosting and display of user defined Web pages created by the user
- SOAP/XML server interface.

#### Alarm Viewer function

“Alarm Viewer” is a ready-to-use, password-protected function. This function is used to manage the alarms (display, acknowledgment and deletion) generated at PLC level by the system or using diagnostic function blocks known as DFBs (system-specific diagnostic function blocks and application-specific diagnostic function blocks created by the user).

These alarms are store in the PLC diagnostic buffer (specific memory area used to store all diagnostic events), this function is available with the Premium/Atrium platforms (with PL7 or Unity Pro software) and the Quantum automation platform (with Unity Pro software).

The diagnostics viewer consists in a Web page displaying a list of messages, with the following information:

- Time stamping of the appearance/disappearance of the fault.
- Alarm message
- Alarm status
- Type of associated diagnostic function block (DFB).

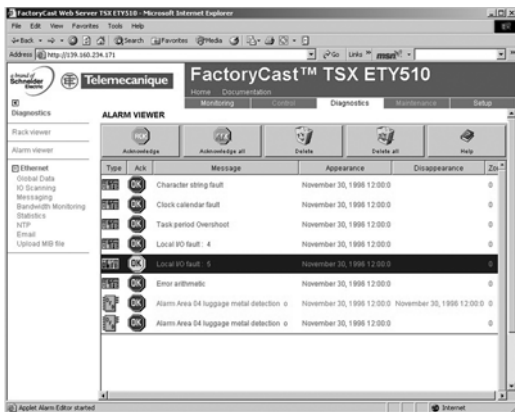

#### Graphic Data Editor function

This function is used to create graphical views animated by PLC variables. This graphic editor is available online “ready-to-use” and also offline using FactoryCast configured software.

These views are created by simple copy/paste operations, using a library of predefined graphic objects. The object parameters are set according to user requirements (colors, PLC variables, labels, etc.).

List of graphic objects provided:

- Analog and digital indicators
- Horizontal and vertical bar charts
- Dialog boxes for displaying messages and controlling/displaying values
- Pushbuttons
- Trending charts
- Tanks, valves, motors, etc.

Many views created can be saved in the Web server modules.

These customized graphic objects can be reused in user defined Web pages that have been created using standard software for editing HTML pages.

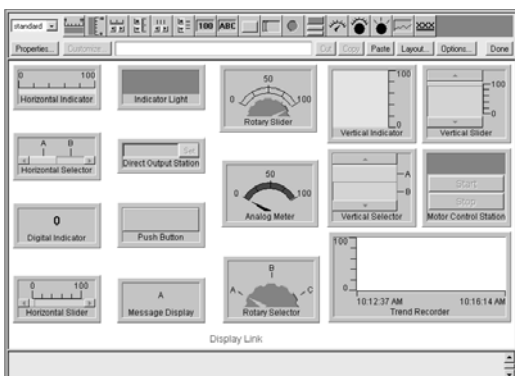



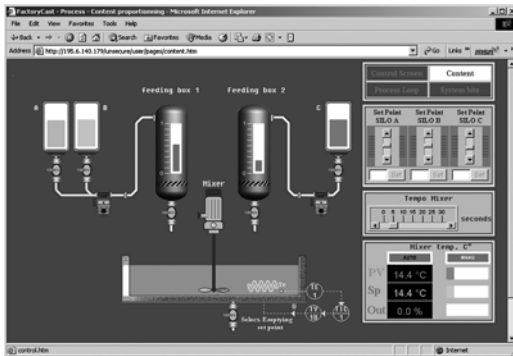

#### FactoryCast configurable PLC Web server (continued)

##### User Web page hosting and display function

FactoryCast Web services also has modules with 8 Mbyte memory (1), which is accessed in the same way as a hard drive and can be used to host Web pages and all user-defined documents in Word or Acrobat Reader (for example, maintenance manuals, diagrams, etc).

These Web pages can be created using any standard tool, for example Microsoft FrontPage, that enables creation and editing in HTML format. These pages can be enhanced by inserting animated graphic objects linked to PLC variables. These animated objects are created using the Graphic Data Editor supplied with FactoryCast.

The Web pages created can be used, for example, to:

- Display and modify all PLC variables in real time
- Create hyperlinks to other external Web servers (documentation, suppliers, etc).

This function is particularly suitable for creating graphic screens used for the following purposes:

- Display, monitoring, diagnostics
- Generation of real-time production reports
- Maintenance help
- Operator guides.

##### SOAP/XML server interface

FactoryCast modules incorporate a standard SOAP/XML data server that provides direct interoperability between automation devices and computer management applications (MES, ERP, SAP, .Net application, etc). See page 32.



##### FactoryCast Web server configuration software

The FactoryCast Web server configuration software is supplied on CD-ROM with every FactoryCast module (TSX ETZ 510 for TSX Micro, TSX ETY 110WS/5103 for Premium, 140 NOE 771 11 for Quantum and TSX ETG 1000/1010 gateways). This software is used for configuration and administration of the Web server embedded in these modules. It is compatible with Windows 2000 and Windows XP operating systems. It provides the following functions:

- Setting the parameters of the FactoryCast functions
- Definition of access security, passwords
- Importing of PLC symbol databases
- Definition of access to write-enabled variables
- Management of the Web site:
  - Management of default Web site pages
  - Management of user Web site pages (2)
  - Graphic object editor for animating Web pages
  - Downloading of Web pages between the PC and the module
  - Debugging of Web pages in online mode or in simulation mode (including animations and Java beans)
- Simulation mode

The application and the Web site (including the Java animations) can be set up in online mode or in simulation mode. Simulation mode is used to test the operation of the Web application without a FactoryCast module (with no physical connection to a PLC) thereby simplifying debugging.

A graphics editor integrated in the configuration software can be used for easy customization of graphic objects (bar charts, gauges, LEDs, curves, cursors, operator input fields, alphanumeric display fields, buttons, etc).

- Creation of user Web pages (2)

User Web pages are created graphically using an external HTML editor (FrontPage or similar, not supplied).

User Web pages created in the FactoryCast environment are actual animated supervision screens and can be used to monitor your process. Based on Web technologies (HTML and Java) they provide real-time access to PLC variables using the FactoryCast graphic object library (Java beans).

(1) Memory not affected by power outages or reinitialization of the PLC.

(2) FactoryCast includes a plug-in for FrontPage 2000. This plug-in makes it easier to set up animations for real-time access to the PLC variables in HTML pages created by the user. They are created in the HTML editor by simply inserting customized graphic objects.

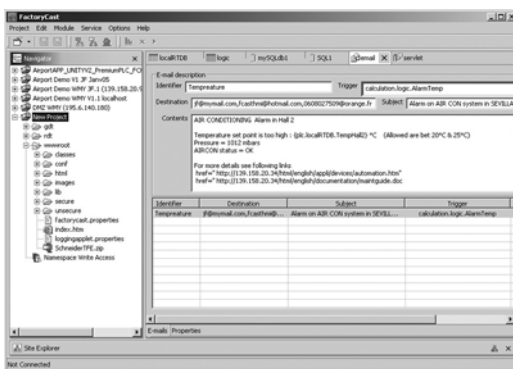

### FactoryCast HMI active Web services

The FactoryCast HMI Web services are integrated in PLC Web server modules on Premium and Quantum PLC platforms.

These modules have the following Ethernet and Web services:

- Ethernet TCP/IP communication functions:
  - TCP/IP messaging service with Modbus TCP/IP and Uni-TE TCP/IP protocols
  - SNMP agent for standardized network management, which supports standard MIB II and private Transparent Ready MIB.
- FactoryCast configurable Web services:
  - “Rack Viewer” PLC diagnostics functions, see page 23
  - “Data Editor” for PLC data monitoring, see page 23
  - “Alarm Viewer” for PLC alarm display, see page 22
  - “Graphic Data Editor” for online graphical PLC data monitoring, see page 22
  - Hosting and displaying user defined Web pages, see page 23.

FactoryCast HMI modules also provide the following specialized HMI Web services:

- Dedicated Real-time Database managed in the module, combining PLC data acquisition and management of local internal variables
- Data processing function with arithmetic and logical calculations
- Database logging function with direct connection to the SQL Server, MySQL and Oracle relational databases for data archiving or tracking
- E-mail notification for alarms and reports
- SOAP/XML client/server interface (see pages 22 and 23)
- Recipe management
- Web based HMI interface with actives Web pages support.

By simply setting parameters, the FactoryCast HMI application development software can be used to set up these functions in an intuitive and user-friendly way. A simulation mode, which is integrated in the software, can be used to test the operation of the FactoryCast HMI application without the need for a physical connection to a module and a PLC, thereby simplifying application debugging.

### Architectures

FactoryCast HMI Web servers can be integrated in various architectures:

- Installations that require a flexible and distributed HMI solution
- Combined architectures supplementing conventional SCADA systems
- Architectures where a direct link is required between automation systems and information management levels (IT link).

### Flexible and distributed Web based HMI solution

The use of Web-based technologies means that FactoryCast HMI can replace conventional HMI or SCADA solutions in applications where architectures require a flexible multistation HMI, thus providing a temporary “nomadic” remote control function.

These architectures consist of:

- Several PLCs networked on Ethernet, equipped with FactoryCast HMI Web server modules ....
- One or more PC terminals simply equipped with a Web browser thus providing a “Thin Client” interface (license free)
- If necessary, a relational database in which FactoryCast HMI can archive data directly from the automation system.

FactoryCast HMI modules read PLC data and execute HMI services (E-mail, interpreted calculations, connection to relational databases, updating Web pages) at source in the PLC, without affecting the PLC program or the scan time.

This solution provides:

- A reliable HMI application, which is executed at source in a robust PLC device.
- An integrated multistation interface and remote access that is easy and cost-effective to set up (“Thin Client” terminal)
- An HMI application that is easy to maintain (the application is housed in a single location on the server side)
- Preventive maintenance via E-mail
- Greater availability of the data archiving done directly from PLC source.

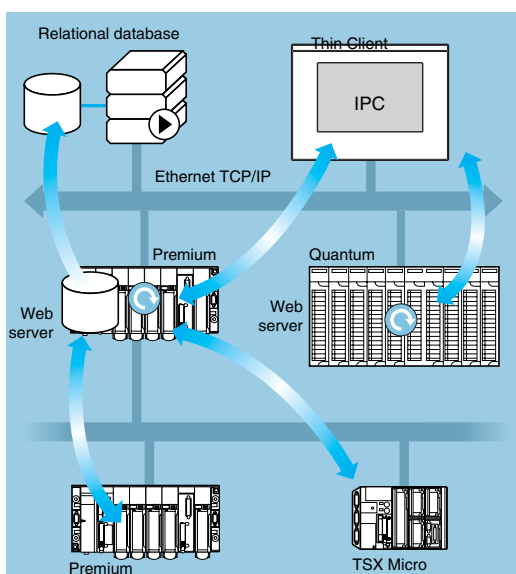

## Architectures (continued)

### Combined architectures

In this type of architecture, FactoryCast HMI supplements conventional SCADA systems such as Vijeo Look or Monitor Pro. SCADA meets the requirement for centralizing information for global supervision from a central site.

Combining a FactoryCast HMI solution and a conventional SCADA solution enables:

- Simplification of the SCADA application by locating some of the SCADA processing function at source, at PLC level
- Increased availability of the traceability function due to the direct connection between FactoryCast HMI modules and relational databases
- Powerful “ready to use” remote diagnostics capacities
- “Nomadic” client stations to be connected to the Intranet or Internet via “Thin Client” PC or PDA devices.

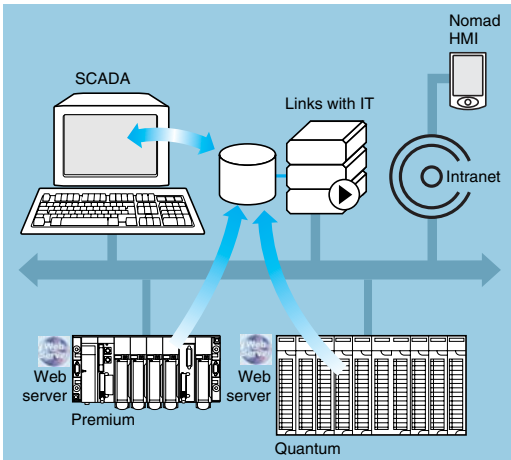

### Direct links with the information management levels

In this type of architecture FactoryCast HMI eliminates the need for intermediate devices (software or hardware gateways), which are expensive to install and maintain, by establishing a direct links between the automation levels and the global information management levels (MES, ERP, etc).

The PLC manages the following links which allow a “collaborative” automation system to be set up, making it: easier to share data in real time:

- Directly archives information from the automation system in relational databases, which allows a “collaborative” automation system to be set up, making it easier to share data in real-time
- Directly interacts with IT applications through SOAP/XML client/server interface.

This solution results in:

- Simplified architectures
- Lower installation, development and maintenance costs
- Increased reliability of information (the data is collected at source)
- Increased inter operability with IT applications
- Greater availability of data archiving.

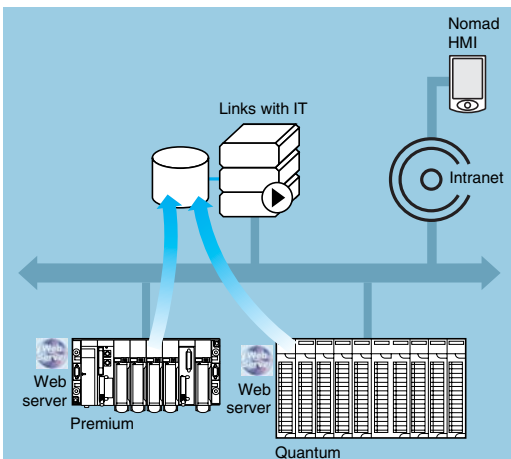

## Specialized HMI services

### PLC data acquisition and real time database

With an internal architecture similar to that of an HMI/SCADA system, FactoryCast HMI modules manage its own variable database in real-time, independently of the PLC program. It is this variable database that is used to execute various functions, including internal processing, archiving, alarm, E-mail, etc.

Variables in this real-time database are updated using the automation system PLC data acquisition service.

This service becomes operational once the following parameters have been set in the FactoryCast HMI software:

- Direct import of PLC variable/symbol databases (no double entry).
- Definition of the frequency of acquisition (period at which the variables are updated).

**Note:** A FactoryCast HMI application running in a Premium configured FactoryCast HMI module can access also the remote PLC variables in the architecture transparently on the network (X-Way/Uni-TE transparent protocols).

### Characteristics:

- Maximum number of I/O variables per application: 1000 variables from PLCs
- Maximum number of internal variables per application: 100
- Acquisition frequency: 500 ms, minimum.

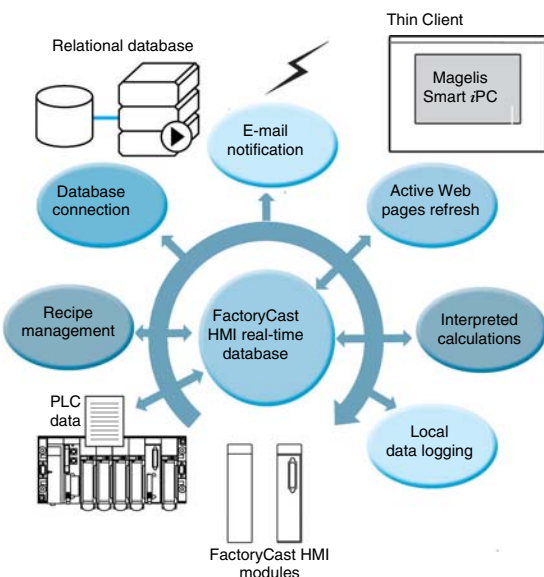

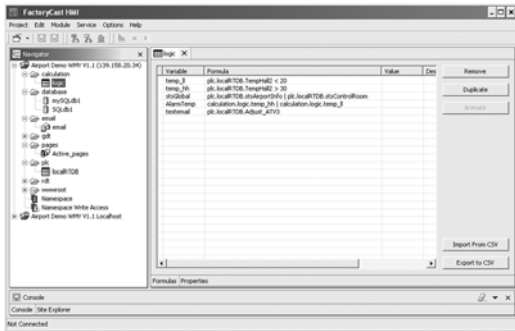

## Specialized HMI services (continued)

### Calculation functions

The FactoryCast HMI server can carry out various arithmetic and logical operations on a combination of variables from the HMI database. These calculations include, for example, scaling, formatting, logic processing for event triggering, etc.

This calculation function can be used for local data processing independently of the PLC CPU processor and is provided in the form of spreadsheets where the formulae are defined in cells. The spreadsheets are interpreted and processed by the server. The result of each formula is associated with a new internal variable. The processing of each spreadsheet is initiated by a trigger.

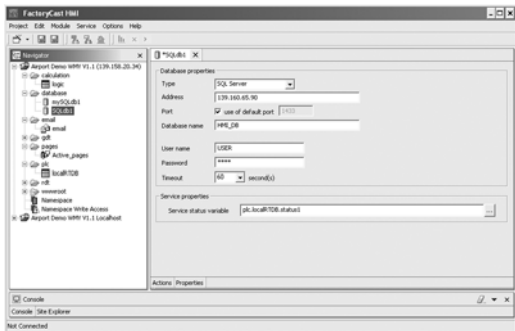

### Connection to relational databases

The FactoryCast HMI module can be connected directly and completely autonomously to the following remote relational databases:

- SQL Server
- MySQL
- Oracle

This connection enables all internal or process data to be archived directly from the FactoryCast HMI module without any intermediary system (hardware or software).

The data can be archived (written) periodically and/or on a specific event. These variables can either be from PLCs (I/O bits, internal bits, internal words and registers) or local to the module. The FactoryCast HMI "Roll Over" function checks the size of tables by managing the maximum number of records. This circular data archiving function automatically deletes the oldest data and can be accessed by simply setting parameters in the FactoryCast HMI software.

### Characteristics:

- Number of databases that can be connected: 3
- Number of tables that can be written per database: 10, maximum
- Number of columns per table: 50, maximum
- Type of database supported: Oracle, SQL Server and MySQL
- Automatic table creation: The FactoryCast HMI server automatically creates a table in the database if one does not already exist

### E-mail notification

The FactoryCast HMI module can, on a specific event, send E-mail completely autonomously to a predefined list of E-mail addresses. This function is executed independently of the PLC program.

The event that triggers the E-mail may be associated with the following:

- A PLC variable (I/O, internal variable)
- An alarm, a threshold overshoot
- A machine or process state
- An operator action, etc.

When an E-mail is sent, it is relayed through an SMTP (*Simple Mail Transfer Protocol*) server to a destination E-mail address. The E-mail service is compatible with all SMTP servers. A return address can be defined should delivery to the destination address fail.

This E-mail notification is very efficient for advanced remote diagnostic, maintenance, data alarming and reporting. The text of the E-mail can contain information such as real-time process values integrated in the message of the mail useful for reporting additional live information to the end user and also hyperlinks to other Web pages or documents (maintenance guide, schematics, etc) in the module or to other Web sites to serve as a guide to the end user.

### Characteristics:

- Configuration of the SMTP server: Compatible with all SMTP servers
- Maximum number of E-mail: 100
- Contents of E-mail messages: Free text with embedded dynamic values and hyperlinks (unlimited).

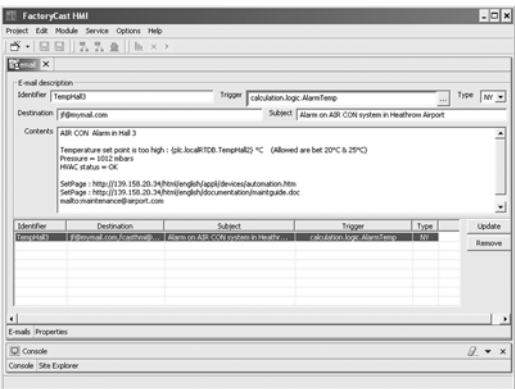

### Specialized HMI services (continued)

#### Local data logging

FactoryCast HMI modules can process data into a file internally in its flash memory. This file can be either:

- exported via FTP
- attached to an E-Mail.

This feature is particularly useful for stand alone installations or substations which are not connected to an intranet or for data storage backup.

#### SOAP/XML client/server interface

For total interoperability purpose, FactoryCast HMI implements SOAP/XML Web service as a:

- Server function so that it can answer to SOAP requests generated by any client application (MES, ERP, SAP, SCADA or third party application running on .NET or Java environment)
- Client function so that it can take the initiative to send SOAP requests to a SOAP server application (another FactoryCast module or an ERP, MES, IT program to exchange data.

See page 32 and 33.

#### Recipe management

The recipe function allows FactoryCast HMI application to read “Recipe” files automatically on process event or operator command and apply the recipe values by writing them in a single shot to the PLC memory.

This function brings great flexibility in operations providing capability to simply execute production changes by modifying manufacturing or process set points and parameters.

#### Characteristics:

- “Recipe” files are described in XML format (SOAP/XML format)
- “Recipe” files can be stored locally in the module or on a remote system
- “Recipe” files contain a consistent set of values conforming a recipe template, values which are written in the PLC memory.

#### Web based HMI interface

The memory of FactoryCast HMI Web server is open to hosting user defined Web pages in order to provide a graphical HMI interface.

Its Active Web server provides a dynamic refresh of the Web pages generated by the server itself.

FactoryCast HMI supports two types of Web pages:

- HTML pages animated in real-time with graphical Java objects which are useful for creating graphical human machine interface (FactoryCast HMI comes with a complete graphic objects Java library).
- Active Web pages dynamically generated by the server itself with integration of PLC variables values inside the HTML code (PLC “tags”) which can be used for reporting purpose. These active pages consisting in pure HTML code are fully compatible either with “thin client” terminal devices such as Pocket PC, PDA, or with any standard PC.

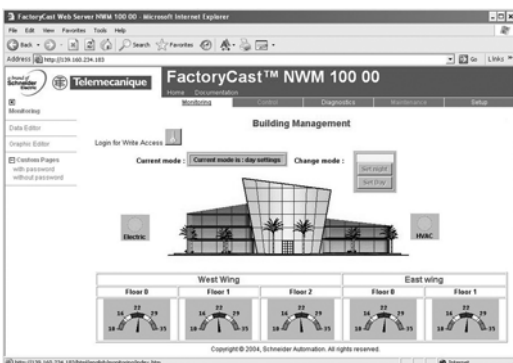

#### FactoryCast HMI application development software

FactoryCast HMI application development software, referenced TLX CD FCHMI V1M, provides multi-project management and complete control of FactoryCast HMI applications, during both the development and the debugging phases, thanks to the online mode and simulation mode (operational when the system is offline).

This software enables the intuitive and user-friendly setup of HMI functions by simply setting parameters using a tree structure of the application and can be used for complete management of the Web site:

- Setting parameters for HMI functions.
- Management of the Web site.
- Simulation mode.

See page 115 for product data sheet.

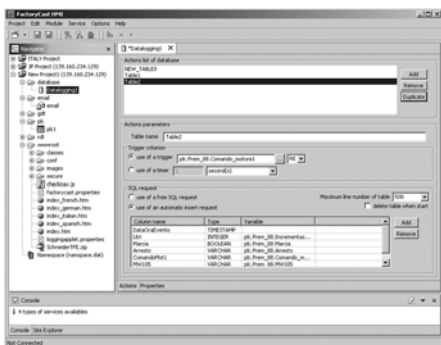



TSX ETG 1000    TSX ETG 1010

## Presentation

FactoryCast Gateway is a new offer of “all in one” intelligent Web gateways integrating, in a stand alone compact unit:

- All the TCP/IP network communication and serial link (Modbus or Uni-Telway) interfaces
- An RAS (*Remote Access server*) / IP Router
- A customizable Web server.

TSX ETG 1000/1010 gateways are a low-cost response to the need to integrate serial link installations in an existing Ethernet TCP/IP infrastructure as well as requirements for remote access services including remote diagnostics, remote maintenance, remote monitoring and remote control.

Two gateway modules are offered:

- TCP/IP – Modbus TSX ETG 1000 gateway
- TCP/IP – Uni-Telway TSX ETG 1010 gateway.

(1) RAS Remote Access Server

## Application examples

### Integration of serial devices (Modbus or Uni-Telway) in an Ethernet TCP/IP network infrastructure

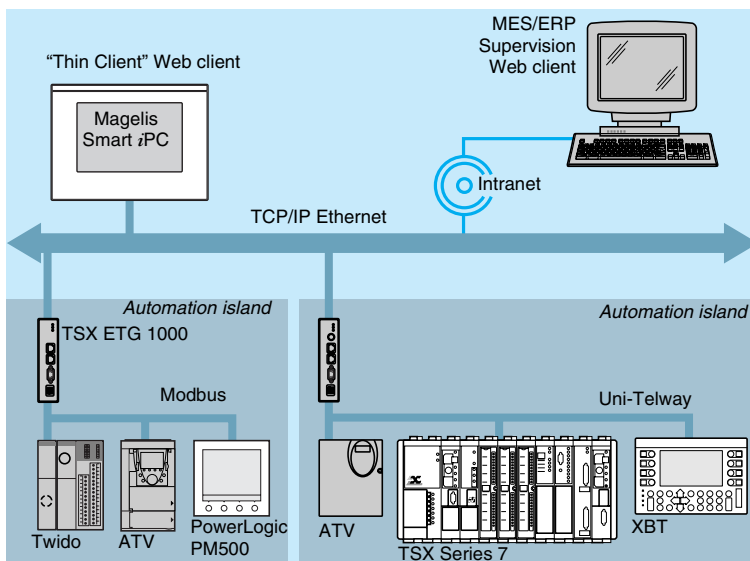

TSX ETG 1000/1010 gateways provide a simple and low-cost means of integrating any existing Modbus serial RTU or Uni-Telway device, installation or automation island in an Ethernet TCP/IP network infrastructure. Each gateway is able to make the serial devices (Modbus or Uni-Telway) directly accessible to computer management (MES, ERP) or supervision applications in real-time.

The following serial devices can be used:

- On Modbus, with the TSX ETG 1000 gateway: Twido controllers, Compact/Momentum/Premium/Quantum PLCs, Altivar drives, Altistart motor starters, Magelis terminals or any other product compatible with the Modbus standard.
- On Uni-Telway, with the TSX ETG 1010 gateway: TSX Micro/Premium/TSX Series 7 PLCs, Altivar drives, Magelis terminals or any other product compatible with the Uni-Telway standard.

In addition, its customizable Web server, accessible from any PC equipped with an Internet browser, offers the following additional services:

- Device diagnostics (Modbus or Uni-Telway)
- Reading/writing of Modbus registers or Uni-Telway variables
- Alarm notification by e-mail
- Hosting of user-defined Web pages.

## Application examples (continued)

### Remote diagnostics and remote maintenance Web portal

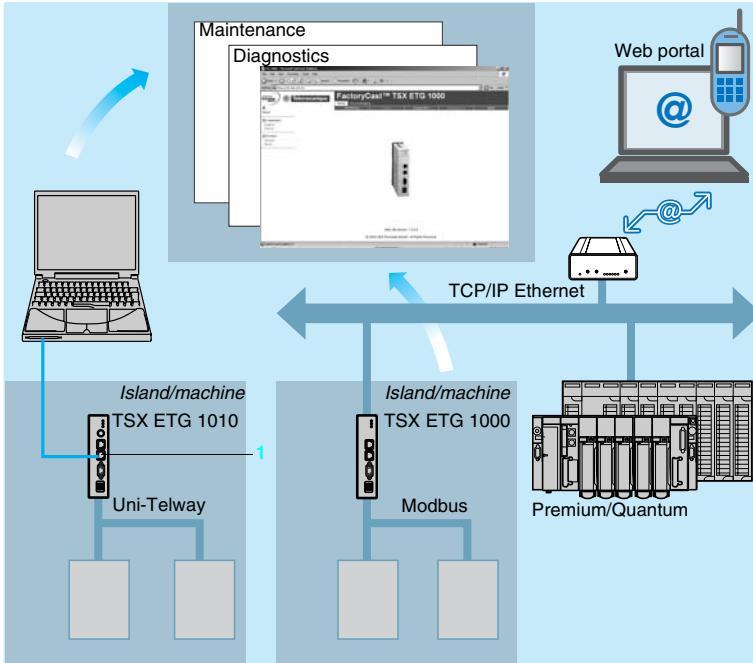

The addition of the FactoryCast Gateway to any stand-alone machine or automation island creates a truly sophisticated maintenance portal, without any modification of Modbus or Uni-Telway serial devices.

This Web portal offers the following functions:

- Configurable Web server
- Alarm notification by e-mail
- Remote diagnostics and remote maintenance
- Remote monitoring and control of (Modbus or Uni-Telway) variables via predefined Web pages.

Any PC or "Thin Client" terminal (e.g., Magelis Smart iPC) equipped with an Internet browser can be used to access these services if it is connected:

- Directly to the TCP/IP 1 port on the gateway
- Remotely via the local network, Intranet, Internet, or via a modem link.

The Web server is fully customizable so that it can be adapted to the user's requirements. Both the hosting of Web pages and any other documents created by the user, and also alarm notification by e-mail mean that the user can access the essential parameters in a preventive manner.

From now on, each machine has its own built-in maintenance.

### Remote access to Modbus/Uni-Telway devices via modem

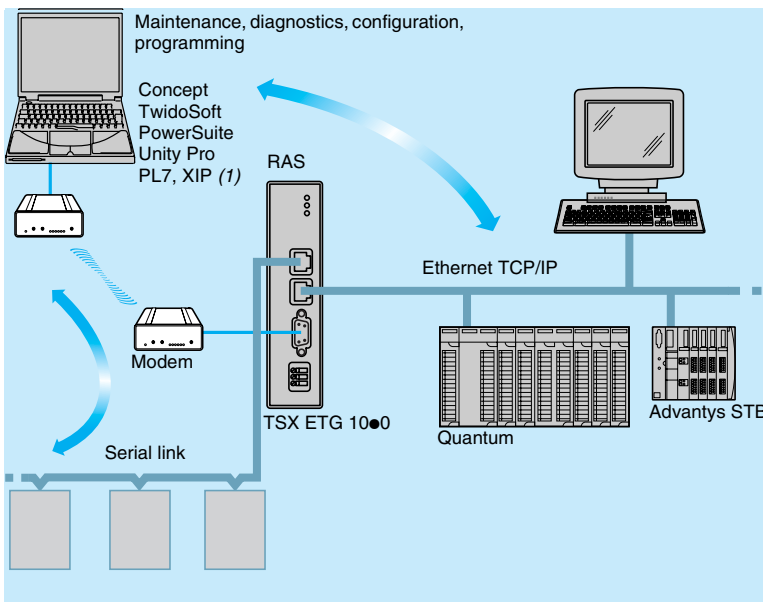

TSX ETG 1000/1010 gateways integrate an RAS (*Remote Access Server*) function, which is compatible with all types of modems (RTC, GSM, radio modem, etc.), Intranet/VPN (*Virtual Private Network*) and Internet links.

They support:

- PPP (*Point to Point Protocol*), managing incoming and outgoing calls
- A routing function (IP router) providing transparent access to any device present on the Ethernet TCP/IP infrastructure.
- Secure access integrating an embedded filtering function for IP client addresses in order to control access with password protection (miniature firewall).

This type of connection is suitable for remote maintenance and remote diagnostics when there are a large number of sites to be monitored, spread over a wide geographical area.

In addition, it can be used to configure and program:

- Remote Modbus devices using Telemecanique brand software (Unity Pro, Concept, TwidoSoft, PowerSuite, etc.)
- Remote Uni-Telway devices using Telemecanique brand software (Unity Pro, PL7 Micro, PL7 Junior/Pro, etc.) and the XIP communication driver.

See page 89 for **TSX ETG 1000/1010** product data sheet.



(1) XIP communication driver with Uni-Telway TSX ETG 1010 gateway



#### Presentation

##### SOAP/XML Web Services embedded in the PLC

*When the Telemecanique PLC interacts directly with computer management applications.*

Communication between platforms or applications is now a necessity in a market where **e-manufacturing** and **e-business** are an essential fact of life for companies.

Web service technology currently represents the most successful strategy for ensuring interoperability of heterogeneous software applications via an Intranet or the Internet, independently of any platform, operating system, or programming language.

The standardization of Web services has come about as a result of joint development between **Microsoft** and **IBM**, amongst others, validated at the **W3C** (*World Wide Web Consortium*) as an open "standard".

It now provides all the tools, specifications and environments needed for each platform.

Web services are based on standards such as:

- **XML** (*eXtensible Markup Language*): the universal standard for data exchange
- **SOAP** (*Single Object Access Protocol*) protocol carried via the **HTTP** (*Hyper Text Transfer Protocol*) channel.
- **WSDL** (*Web Services Description Language*) the Web Services description language, in **XML** format.

SOAP is currently considered to be the reference protocol, including in industry. It has since been adopted by the main players such as Microsoft (•NET, SQL Server, Office, etc), IBM (Java, Web Sphere), Lotus, ORACLE, Sub, SAP, ...

*It is now available in control system equipment within the FactoryCast Web server offer embedded in the Telemecanique PLCs.*

##### Embedded SOAP/XML Web Services: ModbusXMLDa Web services

*The Telemecanique PLC integrates the Web services standard.*

This new Transparent Ready service offers the previously unused (or uncommon) possibility of making an IT/e-business application interact directly with the control system levels using the same standards.

With the implementation of ModbusXMLDa (*Modbus XML Data access*) Web services in FactoryCast Web servers, the IT engineer can easily create his own application which will access the desired information directly in the PLC and in real time.

Data exchanges are made in XML standard format in response to a request using SOAP protocol.

The implementation of Web services in control system equipment makes it easy to achieve vertical integration of the control level and the creation of even more collaborative architectures which can be used to link production systems to the corporate management systems. It brings simplified access to information, a reduction in the costs of training, development and deployments costs, plus an increase in productivity.



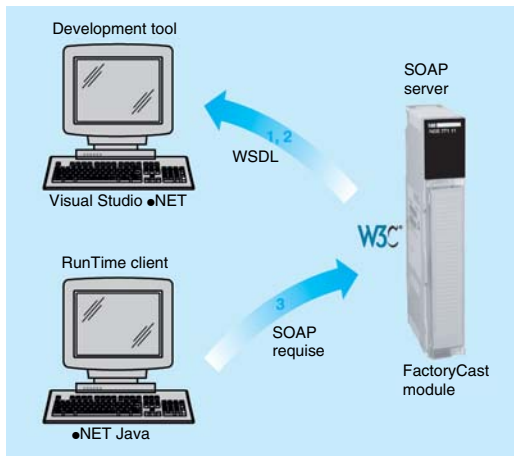

### Implementation of the ModbusXMLDa Web services in FactoryCast modules

#### ModbusXMLDa server interface

This implementation enables a SOAP client application (management level computer application, MES, ERP, etc) to communicate directly with a FactoryCast Web server module embedded in the PLC. Exchanges are initiated by the SOAP client application (the server responds to these requests).

- **Step 1: Creation of the client application with learning of the Web services.** The development environment (for example, Visual Studio .NET) looks in the FactoryCast server for the list of available services and their WSDL standard interfaces provided by the module.
- **Step 2: Development of the client application.** The developer integrates the Web service functions using the code retrieved at the learning stage.
- **Step 3: Execution of the client application.** The client application communicates in real time with the FactoryCast Web server module using the SOAP protocol.



#### ModbusXMLDa client interface

This implementation allows a FactoryCast HMI module to execute a SOAP client application in order to communicate with a remote SOAP server application (for example another FactoryCast Web server module or a computer management application, MES, ERP, etc).

Exchanges are initiated by the FactoryCast HMI client module (the remote application server responds to SOAP requests sent by the FactoryCast HMI module).

- **Step 1: Configuration of ModbusXMLDa client service.** The user declares the PLC variables that are to be exchanged (in read or write mode), using the FactoryCast HMI configuration software.
- **Step 2: Use of the application. ModbusXMLDa client service** executed in the FactoryCast HMI module communicates directly with the remote server application using SOAP requests in XML format.

### Selection guide and list of implemented SOAP requests

The ModbusXMLDa functions are implemented in the following FactoryCast PLC modules.

ModbusXMLDa interface	FactoryCast modules	FactoryCast HMI modules
Server	TSX ETZ 510 TSX Micro module TSX ETY 5103 Premium module 140 NOE 771 11 Quantum module	TSX WMY 100 Premium module 140 NWM 100 00 Quantum module
Client	–	TSX WMY 100 Premium module 140 NWM 100 00 Quantum module

Requests implemented in the FactoryCast modules listed provide either physical or symbolic variables data access. They are defined in the table below.

Access to data via	ModbusXMLDa functions implemented in FactoryCast modules
Physical address	ReadDeviceIdentification
	ReadMultipleRegisters
	WriteMultipleRegisters
	ReadCoils
	WriteMultipleCoils
	ReadDiscreteInputs
Symbol	Read, operation to read item list value
	Write, operation to write item list value
	Browse, operation to browse item list

# Transparent Ready® Products

## System approach

### Ethernet TCP/IP communication service

#### Presentation

Transparent Ready products allow transparent communication on a single Ethernet TCP/IP network.

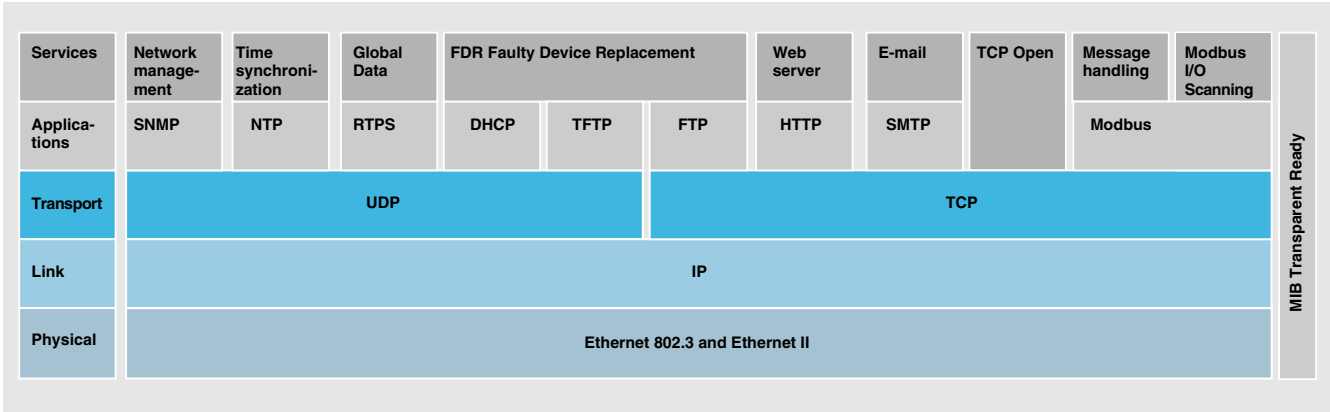

In addition to universal Ethernet services (HTTP, BOOTP/DHCP, FTP, etc), the Transparent Ready device communication services designed for use in automation applications include:

- Modbus TCP/IP messaging for class 10, 20 or 30 devices.
- I/O Scanning service for class 30 devices.
- FDR (Faulty Device Replacement) for class 10, 20 or 30 devices.
- SNMP (Simple Network Management Protocol) network administration for class 20 or 30 devices.
- Global Data, for class 30 devices.
- Module Bandwidth Monitoring for class 30 devices (see performance levels on pages 46 to 49).
- NTP (Network Time Protocol) time synchronization for class 30 devices.
- E-mail notification of application events via SMTP for class 30 devices.
- TCP Open, optional, for class 30 devices.

The following pages present the various options available through all of these services in order to facilitate the optimum choice of solutions when defining a system integrating Transparent Ready devices.

#### Functions

##### Standard Ethernet services

###### HTTP "Hypertext Transfer Protocol" (RFC1945)

The HTTP protocol "Hypertext Transfer Protocol" is used for transmitting Web pages between a server and a browser. HTTP has been used on the Web since 1990.

*Web servers embedded into Transparent Ready devices are used to provide easy access to devices anywhere in the world from a standard browser such as Internet Explorer or Netscape Navigator.*

###### BOOTP/DHCP (RFC1531)

BOOTP/DHCP is used to automatically provide the devices with the IP parameters. This avoids having to manage the addresses of each device individually. Management is instead performed in a dedicated IP address server.

DHCP protocol (Dynamic Host Configuration Protocol) is used to automatically assign the devices their configuration parameters. DHCP is an extension of BOOTP. DHCP protocol is made up of 2 components:

- One for providing the IP network address,
- One for providing the IP parameters specific to the device from a DHCP server.

*Telemecanique devices can be:*

- BOOTP clients allowing automatic recovery of an IP address from a server,
- BOOTP servers enabling a device to distribute IP addresses to the network stations.

*Telemecanique uses standard BOOTP/DHCP protocols for its Faulty Device Replacement service (FDR).*

###### FTP "File Transfer Protocol" (RFCs 959, 2228, and 2640)

File Transfer Protocol (FTP) provides basic file sharing elements. Many systems use FTP protocol to exchange files between devices.

###### TFTP "Trivial File Transfer Protocol" (firmware updates of networking devices)

Trivial File Transfer Protocol (TFTP) is A network transfer protocol that allows to connect to a device and download code onto it. For example, it can be used to shove boot code onto a diskless workstation, or connect and download firmware updates to networking devices

**Note:** *Transparent Ready devices implement FTP and TFTP for transferring certain data to or from devices, in particular when downloading firmware or user Web pages.*

#### Functions (continued)

##### Standard Ethernet services (continued)

##### **NTP** "Network Time Protocol" (RFC 1305)

NTP (Network Time Protocol) is used to synchronize the time of a client or server device from a time server. Depending on the network used, it provides the following time precision based on the UTC:

- Several milliseconds on a local area network (LAN).
- Several tens of milliseconds on a wide area network (WAN).

##### **SMTP** "Simple Mail Transfer Protocol" (RFC 0821)

SMTP (Simple Mail Transfer Protocol) is an E-mail transmission service. It is used to send E-mail between a sender and a recipient via an SMTP E-mail server.

##### **SNMP** "Simple Network Management Protocol" (RFCs 1155, 1156 and 1157)

The Internet community developed standard SNMP for managing the different components of a network through a single system. The network management system can exchange data with SNMP agent devices. This function enables the manager to view the status of the network and devices, modify their configuration and feed back alarms in the event of failure.

*Note: Transparent Ready devices are SNMP-compatible and can be integrated naturally in a network managed via SNMP.*

##### **COM/DCOM** "Distributed Component Object Model"

COM/DCOM (Distributed Component Object Model) or OLE (Object Linking and Embedding) is the name of the technology used in Windows components. This enables Windows applications to communicate transparently.

*Note: These technologies are used in the OFS Data server software.*

Modbus TCP/IP function codes	dec	hexa
<b>Bits access</b>		
Read of n input bits	02	02
Read of n output bits	01	01
Exceptional read status	07	07
Write 1 output bit	05	05
Write of n output bits	15	0F
Read of 1 input word	04	04
Read of n input words	03	03
Write 1 output word	06	06
Write of n output words	16	10
Read device ID	43/14	2B/0E
Access CANopen interface	43/13	2B/0D

Example of Modbus TCP/IP function codes supported for accessing data and diagnostics

## Functions (continued)

### Modbus communication standard

Modbus, the industrial communication standard since 1979, has been combined with Ethernet TCP/IP, which supports the Internet revolution, to make Modbus TCP/IP, a completely open Ethernet protocol. The development of a connection to Modbus TCP/IP requires no proprietary component or license purchase.

This protocol may be easily combined with any device supporting a standard TCP/IP communication stack. Specifications can be obtained free of charge from the website: [www.modbus-ida.org](http://www.modbus-ida.org)

### Modbus TCP/IP, simple and open

The Modbus application layer is very simple and universally recognized with its 9 millions installed nodes. Thousands of manufacturers are already implementing this protocol. Many have already developed a Modbus TCP/IP connection and many products are currently available.

The simplicity of Modbus TCP/IP enables any small field team, such as an I/O module, to communicate over Ethernet without the need for a powerful micro-processor or a lot of internal memory.

### Modbus TCP/IP, high-performance

Because of the simplicity of its protocol and the high speed of 100 M bits/s Ethernet, Modbus TCP/IP delivers excellent performance. This means it is possible to use this type of network in real-time applications such as I/O Scanning.

### Modbus TCP/IP, one standard

An identical application protocol is used for Modbus serial link, Modbus Plus or Modbus TCP/IP. This therefore makes it possible to route messages from a network to another without changing protocol.

As Modbus is implemented above the TCP/IP layer, users can also benefit from the IP routing which enables devices located anywhere in the world to communicate without having to worry about the distance between them.

Schneider Electric offers an entire range of gateways for interconnecting a Modbus TCP/IP network to already existing Modbus Plus or Modbus serial link networks. See product data sheets, pages 88 to 90, 92 and 93.

The IANA institute (Internet Assigned Numbers Authority) has assigned Schneider Electric port TCP 502 (Well known port), which is reserved for the Modbus protocol. So, it is a standard within the Internet community.

A study by ARC Advisory Group, the leading analyst firm covering automation and enterprise software, shows Modbus TCP/IP as the World's leading industrial Ethernet protocol, in terms of units shipped in 2004.

Modbus and Modbus TCP/IP are recognized by IEC 61158 international standard as a fieldbus. They are also "Chinese National Standard" managed by ITEI.

### CANopen interfacing Modbus TCP/IP

CiA DSP 309-2 provides a standardized mapping of CANopen data for transport on Modbus TCP/IP networks. In the specification Modbus function code 43/13 is reserved for this purpose. The reservation of this function code is exclusively for CANopen (see page 95 for more details).

### Modbus TCP/IP characteristics

Maximum size of data:

- Read: 125 words or registers.
- Write: 100 words or registers.

#### Functions (continued)

#### I/O Scanning service

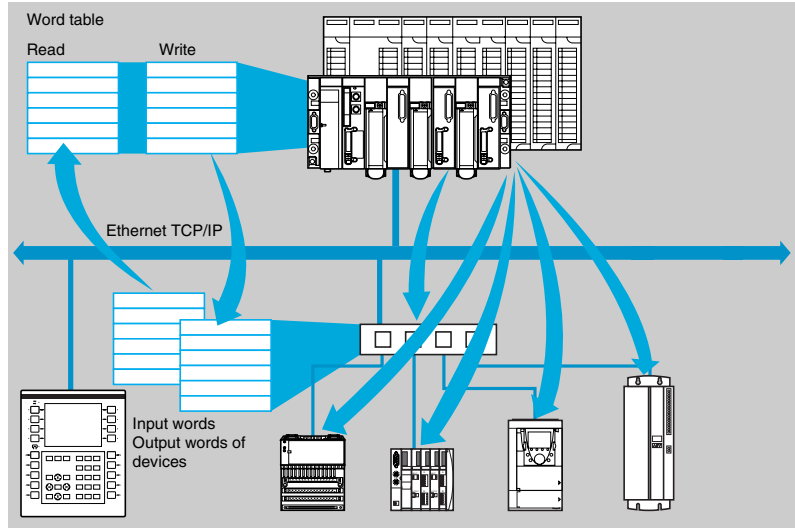

The I/O Scanning service can be used to manage the exchange of distributed I/Os on the Ethernet network after a simple configuration operation, with no need for special programming.

The I/Os are scanned transparently by means of read/write requests according to the Modbus Master/Slave protocol on the TCP/IP profile. This principle of scanning via a standard protocol enables communication with any device which supports a Modbus server on TCP/IP.

This service can be used to define:

- An %MW word zone reserved for reading inputs
- An %MW word zone reserved for writing outputs
- Refresh periods independent of the PLC scan.

During operation, the module:

- Manages the TCP/IP connections with each of the distributed devices
- Scans the devices and copies the I/Os into the configured %MW word zone
- Feedback status words so that correct operation of the service can be monitored from the PLC application
- Applies the preconfigured fallback values in the event of a communication problem.

An offer of hardware and software products which enable the I/O Scanning protocol can be implemented on any type of product connected to the Ethernet network (please consult: [www.modbus-ida.org](http://www.modbus-ida.org)).

#### Characteristics

- Each station can exchange, with Unity software a maximum of:
  - 100 words for writing
  - 125 words for reading.
- Maximum size in the PLC managing the service:
  - 2 K words %MW (1) in inputs and 2 K words %MW (1) in outputs with manager PLC (64 stations max.)
  - 4 K words %MW (1) in inputs and 4 K words %MW (1) in outputs with manager PLC (128 stations max.).

#### I/O Scanning service diagnostics

I/O Scanning service diagnostics can be performed in 3 ways:

- By the application program from a data field specific to the PLC
- From the debugging screen in the programming software
- From the PLC system diagnostics function viewed with the Internet browser on a PC station.

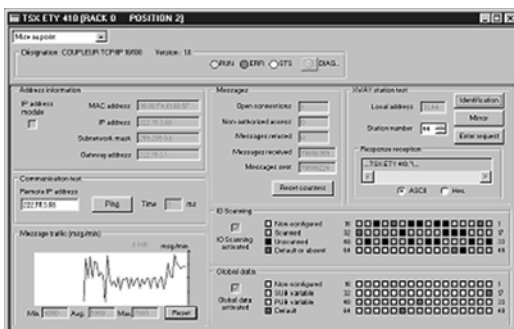

(1) or 4x registers with Concept or ProWORX.

#### Functions (continued)

##### **FDR (Faulty Device Replacement), replacement service for faulty devices**

The Faulty Device Replacement service uses the standard BOOTP/DHCP, file management and TFTP (Trivial File Transfer Protocol) technologies with the objective of simplifying Ethernet device maintenance.

It enables a faulty device to be replaced by a new product while guaranteeing its detection, reconfiguration, and automatic restart by the system, without difficult manual intervention.

The principal steps are:

- 1 A device using the FDR service is faulty.
- 2 Another similar device is taken from the maintenance pool, preconfigured with the "Device\_name" (or identifier) of the device that is out of service, then reinstalled on the network. The identifier is set by the position of the rotary switches, as for Advantys STB, **a** or Advantys OTB distributed I/O. The "Device\_name" should be given with a keypad, for Altivar variable speed drives.
- 3 The FDR server detects the new addition, configures that device's IP address and transfers the configuration parameters to it.
- 4 The substituted device verifies if all the parameters are indeed compatible with its own characteristics, then switches to operating mode.

The FDR server can be:

- Premium processor with embedded Ethernet TSX P57 ●●●●M,
- Quantum processor with embedded Ethernet 140 CPU 651 50/60,
- Premium Ethernet module TSX ETY 4103/5103,
- Quantum Ethernet module 140 NOE 771 01/11.

See pages 101 to 105.

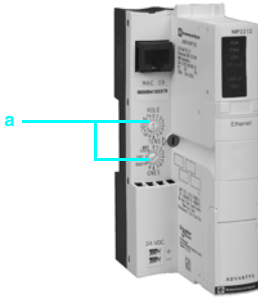

#### Functions (continued)

#### Global Data service

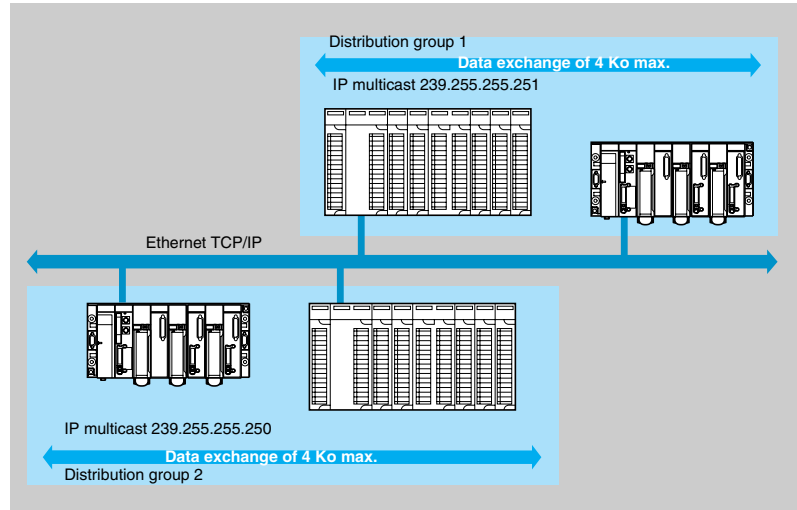

The Global Data service ensures data exchanges in real-time between stations belonging to the same distribution group. It is used to synchronize remote applications, or share a common database among several distributed applications. The exchanges are based on a standard producer/consumer protocol, guaranteeing optimal performance while maintaining a minimum network load. This RTPS (Real-Time Publisher Subscriber) protocol is promoted by the Modbus-IDA organization (see page 127), and has already been adopted as a standard by several manufacturers.

#### Characteristics

A maximum of 64 stations can participate in Global Data within the same distribution group. Each station can:

- Publish one 1024-byte variable. The publication period can be configured from 1 to n periods of the Mast task of the processor.
- Subscribe to between 1 and 64 variables. Validity for each variable is controlled by Health Status Bits, linked to a refresh time-out configurable between 50 ms and 1 s. Access to a variable element is not possible. The total size of the subscribed variables reaches 4 K contiguous bytes.

In order to optimize Ethernet network performance further still, Global Data can be configured with the “multicast filtering” option, which together with switches in the ConneXium range (see pages 122 to 124), perform data broadcasting only on Ethernet ports, where there is a Global Data service subscriber station. If these switches are not used, Global Data is transmitted in “multicast” on all switch ports.

#### Global Data service diagnostics

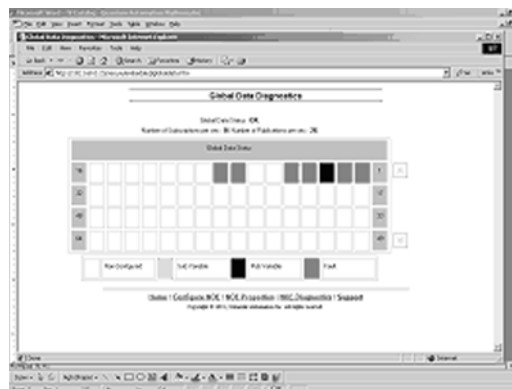

The diagnostics screens use a color code to show Global Data status:

- Configured/not configured/faulty.
- Published/subscribed.



### Functions (continued)

#### NTP time synchronization service

##### Presentation

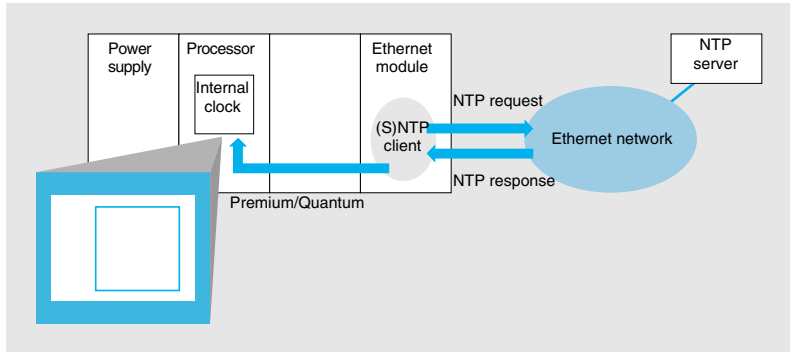

The time synchronization service is based on the NTP (*Network Time Protocol*) which is used to synchronize the time of a client or a server on Ethernet TCP/IP from a server or another reference time source (radio, satellite, etc).

##### Operation

Some Ethernet communication modules for automation platforms:

- **140 NOE 771 11** with the Modicon Quantum Unity V2.0 (or more),
  - **TSX ETY 5103** with Premium Unity V2 (or more),
- have an NTP client component.

These modules can connect to an NTP server using a client request (unicast), in order to update their local time. The module clock is updated periodically (1 to 120 seconds) with an error of less than 10 ms for standard processors and less than 5 ms for high performance processors. If the NTP server cannot be reached, the Ethernet TCP/IP module switches to a standby NTP server.

Ethernet module associated with its Unity processor		Predicted typical time service precision		
Ethernet modules	Unity processors	Clock synchronization (1)	Event synchronization	Time stamping (2)
TSX ETY 5103	TSX P57 0244M TSX P57 1●4M TSX P57 2●4M TSX P57 3●4M	± 1 ms typical ± 10 ms max.	= Clock synchronization precision	= Clock synchronization precision
	TSX P57 4●4M TSX P57 5●4M	± 1 ms typical ± 5 ms max.	+	+
140 NOE 771 11	140 CPU 311 10 140 CPU 434 12U 140 CPU 534 14U	± 1 ms typical ± 10 ms max.	Fast task time	I/O time
	140 CPU 651 50 140 CPU 651 60 140 CPU 671 60	± 1 ms typical ± 5 ms max.	+	
			I/O time	

(1) Time difference between field input and central NTP server.

(2) Assuming input connected to the interrupt module.

The PLC processor clock is therefore itself updated with a precision of 5 ms for standard processors and 1 ms for high performance processors. A function block is available for reading this clock. In each PLC application, events or variables can be time-stamped.

The Ethernet module is configured via a Web page. The time zone can be configured. A time synchronization service (NTP) diagnostic Web page is also available.

Information on the time synchronization service (NTP) is also available in the Transparent Ready private MIB, which can be accessed via the SNMP network management service (see above).

### Functions (continued)

#### SMTP electronic mail notification service

##### Introduction

This simple mail notification service is a programmed service that allows PLC applications to report by exception conditions monitored by the PLC. The automation controller can automatically and dynamically create electronic mail to alert specified users with data, alarms and events - whether the recipients are local or remote.

Note: This service is available on the latest Premium and Quantum Ethernet modules & CPUs, when operating with Unity Pro software. A more comprehensive mail service, independent of the PLC application, is available on the FactoryCast HMI active web server modules (see page 29)

##### Usage

A simple yet powerful mechanism is used. Predefined email headers are linked together with the body of the mail which is created dynamically from the latest information in the automation application.

The user logic program can trigger the message based on a predefined event or condition. Using a function block, one of 3 predefined headers is selected and an email message with variable information and text (up to a maximum of 240 bytes) is created and sent directly from the PLC.

Each of the three mail headers contains these common predefined items –email recipient list, sender name and subject. This information can be defined and updated by an authorized administrator using the configuration web pages.



##### Message creation and delivery

The PLC application selects the appropriate header. The system architect may define the mail headers to indicate differing importance levels. For example:

- Header 1 could be “URGENT problem reported by PLC 10”,
- Header 2 might be “WARNING at substation 10”,
- Header 3 could be “INFO message from water system”.

Differing lists of recipients between the three headers help to ensure that the right information quickly flows to the right recipients. The application can then add pertinent information to the body of the mail message such as the specific device, process or location.

Completed mail is then sent to an electronic mail server for expeditious distribution to the interested parties. These recipients could be engineers, managers, process owners etc.

##### Security

Each mail message can be protected by an optional login and password that is authenticated by the SMTP mail server. If, for additional security, the site’s mail installation has changed the TCP port number from the default of 25, the port number can be changed in the PLC email configuration (via secured web page access).

##### Configuration

An authorized administrator can use a web page to easily configure the mail service. For each of the three mail headers, the sender; recipient list and subject message can be defined. The electronic mail server connection information such as IP address and security information can also be set from the web page.

##### Diagnostics

As all other Ethernet services in Premium and Quantum systems, the Mail Service has a Diagnostic Web page showing the complete, up to the second, status.

##### Remote Monitoring

These products provide diagnostic information for remote management applications following the SNMP network management standard. Information for the mail service is included in the Schneider Electric private MIB which is publicly available.

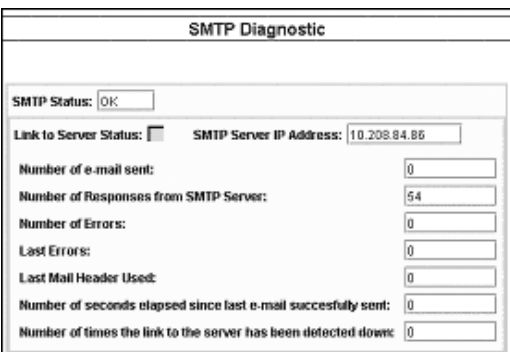

#### Functions (continued)

##### SNMP service protocol

The SNMP (Simple Network Management Protocol) protocol is used, from a network management station, to monitor and control all Ethernet architecture components and thus ensure rapid diagnostics if a problem occurs.

It is used to:

- Query devices such as computer stations, routers, switches, bridges or terminal devices (DTE) in order to view their status
- Obtain statistics for the network on which the devices are connected.

This management software respects the traditional Client/Server model. However, in order to avoid confusion with other communication protocols using this terminology, we prefer to use these definitions:

- IntraVUE from Network Vision (see partner sheet page 141)
- Network manager for the Client application running on the computer station
- SNMP agent for the server application that runs on the device.

Transparent Ready can be managed by any SNMP network manager, including HP Openview or IBM Netview.

Standard SNMP (Simple Network Management Protocol) is used to access configuration and management objects included in the MIB (Management Information Base) for the devices. These MIBs must comply with certain standards in order to be accessed by all managers on the market. However, depending on the device complexity, manufacturers can add certain objects to the private databases.

The Transparent Ready private MIB includes management objects specific to the Telemecanique offer. These objects simplify installation, implementation, and maintenance for Transparent Ready products in an open environment using standard network management tools.

The Transparent Ready products support 2 SNMP network management levels:

- Standard MIB II, a first level of network management, can be accessed via this interface. It lets the manager identify the devices forming the architecture and retrieve general information on the configuration and operation of the Ethernet TCP/IP interfaces
- MIB Transparent Ready interface; management of the Transparent Ready devices is improved via this interface. This MIB includes a set of data that enables the network management system to supervise all the Transparent Ready services. The Transparent Ready private MIB can be downloaded from the Web server from any Ethernet Transparent Ready module in a PLC.

#### TCP Open optional service

##### Presentation

**TSX ETY 110 WS/5103** Premium platform Ethernet modules support a number of communication protocols based on the TCP/IP standard. Among these, the Modbus protocol has public specifications and its simplicity recommends it for the needs of communication with third-party devices.

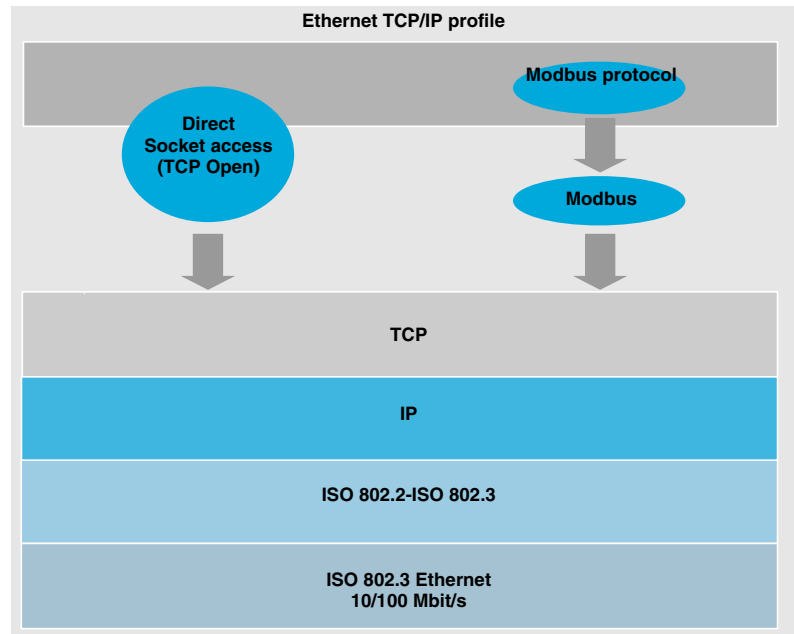

However, for certain applications, it may prove necessary to use other protocols. This is the case when, for example, users wish to integrate Modicon Premium platforms into existing architectures which use a particular communication protocol, possibly a proprietary one.

To meet these needs for open access, 2 interface levels are included in the Telemecanique offer:

- A library of basic functions, which can be used in C language, enables direct access to the socket interface on TCP. The user can thus create his own communication functions using SDKC development software and take advantage of the ease of use which this program offers in terms of development and debugging. Once generated, these function blocks are used in the application like any standard PL7 or Unity Pro programming software function block
- A library of basic function blocks known as EFs, which can be used directly in the application programs with PL7 Unity Pro language. These are the same as functions developed in C language seen earlier, but are designed for use by non-computer specialists. These EF function blocks are not modifiable.

##### Functions

Operating in TCP connection client/server mode, the basic functions on the Berkeley socket interface enable:

- Management of 16 connections on the Open profile out of a maximum of 32
- Creation of sockets and their attachment to any TCP port
- Switching of these sockets to "listen for a connection request from a remote client" mode
- Opening of a connection
- Transmission and reception of data on these connections (8 bytes max.)
- Closing this connection.

#### TCP Open optional service (continued)

##### Description

The TCP Open offer consists of a CD-ROM containing the TCP/IP function libraries. Open access on TCP is only possible via TSX ETY 110WS (1) and TSX ETY 5103 Ethernet modules. With open access on TCP, all the basic functions of these modules can be used.

The TCP/IP **TLX CD TCP 50M** function library comprises:

- The SDKC program enhancement library that provides access to the module TCP/IP socket functions
- The user's manual in English (no printed version)
- EF elementary communication function blocks (Socket/Bind/Listen/Accept/Shutdown/Close/Send/Receive/Select/Set\_Socket Option/Connect) for installation using PL7 software (version ≥ V3.3)
- Higher level EF function blocks, provided by way of example, which can perform more advanced functions such as the complete sequence for establishing or closing a connection, or sending or receiving data. The source files for all these EF blocks are also supplied
- An example of a PL7 application communicating with a TELNET application on a PC.

If customized function blocks are needed both:

- the SDKC program for C language:
  - **UNY SPU ZU CD 20E** (with Unity Pro software)
  - or **TLX L SDKC PL741M** (with PL7 software)
- and the library of function blocks TCP Open **TLX CD TCP50M** should be installed on the development station (see references page 102).

##### Setup precautions

The development of C language functions requires compliance with certain setup precautions:

- To set up these services, the user should be familiar with the TCP/IP profile
- In addition, since the SDKC program enables access to all the PLC internal resources, all the necessary precautions should be taken when developing EF communication blocks to avoid endangering the PL7 application, especially on the commonly fragile operating modes such as cold/warm restarts, response to a fault, etc
- The user should also take care to maintain the requests from the different communication profiles at a level compatible with the performance required by the application
- Finally, it is the responsibility of the client application software (PL7, Unity Pro or C program) to manage the operating modes for communication which may be specific to the application, for example the behavior if a remote device fails to respond or in the event of a break in connection.

For these different reasons, we recommend that you consult your Regional Sales Office to ensure that your TCP protocol open access project is feasible.

(1) Open access on TCP requires **TSX ETY 110 WS** modules, version ≥ PV 03 and SV 2.9. In addition, it should be integrated on a configuration with a **TSX P57 ●●3/●●4** processor (or **TSX P57 ●●2** version > V3.3).

#### Selecting the communication architecture

When selecting an architecture, it is advisable to take performance into account at the earliest possible stage.

When selecting an architecture, the designer must:

- 1 Have a clear idea of his needs as regards:
  - quantity and type of devices to be interconnected,
  - volume and type of exchanges,
  - expected response times,
  - environment.
- 2 Compare his needs with the characteristics of the offers available and be aware that the precise performance level between any 2 points on an architecture is dependent on the weakest link in the chain, which can be:
  - a function of the hardware,
  - but also a function of the applications (size, architecture, OS, machine power, etc.) which are often poorly defined at this stage of the project.
- 3 Select the most suitable architecture.

The objective of the following pages is to provide main information and guidelines to help answering the second point. As performance of an Ethernet architecture is linked to numerous parameters, those pages are not delivering all information needed for a complete calculation of the network performance. They intend to concentrate on the following key aspects:

- **Guidelines to evaluate the network load** to design an Ethernet network answering the application requirement. As network load calculations require numerous parameters we will not intend to describe the whole calculation methodology, but to deliver main guidelines, see pages 46 to 49
- **Application response time** that should be reached depending of the configuration used, see page 51
- **Processing capabilities of Modicon Premium and Modicon Quantum PLCs** to determine the CPU and the number of Ethernet connection required on PLC, depending of the application, see pages 52 and 53.

#### Guidelines to evaluate the network load

##### Introduction

To evaluate the network load of an Ethernet network, calculations of all the communication services of all devices connected to the network are required. Due to Ethernet high performances, in most cases, the load will be easily below the Ethernet network limits and will not have a significant effect on the total application response time. It's due to the high speed of Ethernet: the network transaction time is less than 10% of the total application response time. To ensure a low network load and avoiding huge theoretical calculation, it is strongly recommend to separate the collision domain to limit the network load, using only switched network (tree, star or daisy chain topology), see pages 55 and 56.

The following are guidelines to evaluate the network load. Only switched or daisy chain networks should be used avoiding the system evaluation inside the collision domains.

Guidelines are only for the following Ethernet communication services:

- TCP/IP Modbus messaging
- I/O Scanning
- Global Data

**Other services (as Faulty Device Replacement, Network management SNMP, Web...) and transactions management (account retries and collisions, bandwidth used for establishment and management of the services...) are not taken into consideration in the evaluation guidelines.**

#### Guidelines to evaluate the network load (continued)

Modbus request/response	Total PDU	Function code	Param.	Data
	length	length	length	length
<b>Read coils (01)</b>				
Request	5	1	4	0
Response	2 + N	1	1	N
<b>Read discrete inputs (02)</b>				
Request	5	1	4	0
Response	2 + N	1	1	N
<b>Read holding register (03)</b>				
Request	5	1	4	0
Response	2 + N	1	1	N
<b>Read input register (04)</b>				
Request	5	1	4	0
Response	2 + N	1	1	N
<b>Write single coil (05)</b>				
Request	5	1	4	0
Response	5	1	4	0
<b>Write single register (06)</b>				
Request	5	1	4	0
Response	5	1	4	0
<b>Write multiple coils (15)</b>				
Request	6 + N	1	5	N
Response	5	1	4	0
<b>Write multiple registers (16)</b>				
Request	6 + N	1	5	N
Response	5	1	4	0
<b>Read file record (20)</b>				
Request	9	1	8	0
Response	4 + N	1	3	N
<b>Write file record (21)</b>				
Request	9 + N	1	8	N
Response	9 + N	1	3	N
<b>Mask Write registers (22)</b>				
Request	7	1	6	0
Response	7	1	6	0
<b>Read/write multiple registers (23)</b>				
Request	10 + M	1	9	M
Response	2 + N	1	1	N
<b>Read device identification (43)</b>				
Request	4	1	3	0
Response	7 + $\Sigma(2 + K_i)$	1	6	$\Sigma(2 + K_i)$

#### Evaluation of TCP/IP Modbus messaging

Evaluation of bandwidth used by TCP/IP Modbus messaging is particularly complex because a lot of parameters are changing for each requested transaction of the application program.

#### Transaction periodicity

Periodicity of transaction is not so simple to determine. The request could be sent at the task period of the initiator, but the response depends on the task period of the destination station. If there is a lot of traffic on the network, the response may take several periods. All these parameters have to be evaluated before entering the period of the transactions.

#### Length of messages

- One part of the message has always the same length, due to successive encapsulations: Ethernet (26), IP (24), TCP (24), and Modbus-MBAP (7), giving a total of 81 bytes, to this 12 bytes is added corresponding to the Inter Packet Gap
- Second part of the frame has a length, which depends of the length of Modbus PDU request/response and its parameters. The different cases are listed in the attached table (*value in bytes*).

**Note :** (1)N = Number of coils / 8 or  
 N = Number of coils / 8 + 1 (remainder ≠ 0)  
 (2)N = Number of inputs / 8 or  
 N = Number of inputs / 8 + 1 (remainder ≠ 0)  
 (3)N = Number of registers x 2  
 (4)K<sub>i</sub> = Length of object i; with i = 1 to n,  
 where n = number of objects.

For the evaluation of the bandwidth used by Modbus TCP/IP messaging it's necessary to have the following characteristic parameters for each transaction:

- 1 Period of sending message *in ms*
- 2 Size of the Modbus PDU of the request *in bytes*
- 3 Size of the Modbus PDU of the response *in bytes*

The evaluation of the network load of the Modbus TCP messaging service in bite/s is made with the following formula:

$$(186 + \text{size of the Modbus PDU of the request} + \text{size of the Modbus PDU of the response}) \times 8000 / \text{period of sending message}$$

The calculation must be made for each scanned device of each transaction.

#### Evaluation of I/O Scanning

For the evaluation of the bandwidth used by I/O Scanning it's necessary to have the following characteristic parameters of each scanned station:

- 1 Period of scanning *in ms*
- 2 Size of the read variable *in words*
- 3 Size of the write variable *in words*

**Note :** The scanning period is limited by scanned device response time.

The evaluation of the network load, I/O Scanning service in bit/s is made with the following formula:

$$(103 + 2 \times \text{size of the read variables} + 95 + 2 \times \text{size of the write variables}) \times 8000 / \text{period of scanning}$$

The calculation must be made for each scanned device of each scanning station.

# Transparent Ready® Products

## System approach

### Performance of Ethernet TCP/IP network

#### Guidelines to evaluate the network load (continued)

##### Evaluation of Global Data

For the evaluation of the bandwidth used by the Global Data service, it's necessary to have the list of all the variables belonging to the same Multicast group, with their characteristic parameters:

- 1 Distribution period *in number of scan*
- 2 Period of Mast Task *in ms*
- 3 Size of variable *in number of words*

These parameters must be collected in each station publishing at least one variable in the Multicast group.

The evaluation of the network load of the global data service in bite/s is made with the following formula:

$$(\text{Size of variable} \times 2 + 90) \times (1000 / (\text{Period of Mast Task} \times \text{distribution period}))$$

This calculation must be made for all variables of all Multicast groups.

##### System evaluation

- Previous evaluations give indication of traffic when considering
- One station when sending Messages or I/O Scanning requests
  - A group of stations belonging to the same Global Data group.

The final objective is to have an evaluation of traffic when connecting several stations.

The following information is required for each station:

- Level of traffic the station has to manage (sum of I/O Scanning, messaging and Global Data) calculated previously.
- Collision domain to which the station belongs.

Additional information is required for Global Data traffic:

- Level of traffic in each Global Data group, calculated previously
- List of stations belonging of Global Data groups.

**First step** of system evaluation is traffic calculation inside each collision domain. A collision domain is a domain where hub as used. A switch separates two domains. If only a switched or daisy chain network infrastructure is used (it is strongly recommended to have the lowest possible network load) go directly to the next step. If you use hubs add all traffic of all stations connected to the same collision domain. Calculations are provided in the table below:

Messages transmitted per bit/s from				Total number of messages received per station	
	Station A	Station B	Station N		
Messages per second sent to	Station A			R1	
	Station B			R2	
	Station N			Ri	
Total number of messages transmitted per station		E1	E2	Ei	Network load $Cru = \sum [R1...Ri, E1...Ei]$
Not applicable					

**Second step** is traffic evaluation between collision domains. If only switches and daisy chain are used (avoiding using 2 hubs is recommended) it's only necessary to add the messages transmitted on each link. If hubs are used somewhere in the application, in this step add only the traffic from one hub domain to the other (e.g. going through one switch).



#### Guidelines to evaluate the network load (continued)

##### System evaluation (continued)

**Third step** is to calculate the total traffic of each of the collision domains. For each domain it is necessary to add the “internal” collision domain traffic to the traffic with others collision domains.

Calculation of traffic in one domain applies the following rules:

- When a station belongs to the domain, all the traffic it initiates is included in traffic calculation
- When a station does not belong to the domain, only traffic sent to this domain is included in traffic calculation.

*Note* : In calculations it's presumed that multicast filtering is activated on switches and so the Global Data traffic is propagated on collision domain where there is station belonging to the global data group.

**Fourth step** is to compare the traffic load of each collision domain and the large bandwidth of the Ethernet network (10 Mbit/s, 100 Mbit/s, ...). The user must ensure that the application load does not exceed the usable bandwidth network capacity. Usable bandwidth on automation network is evaluated with a percentage of the hypothetical network capacity. It depends of the industrial Ethernet standard used. The allowed bandwidth is situated between 30 and 40% of the theatrical global bandwidth and depends on the topology used.

If the applications load exceeds the usable bandwidth, it must be reduced, using more switches to reduce the number of stations of the overloaded collision domain (so the internal traffic of the domain) and/or the industrial Ethernet standard used has to be enhanced.

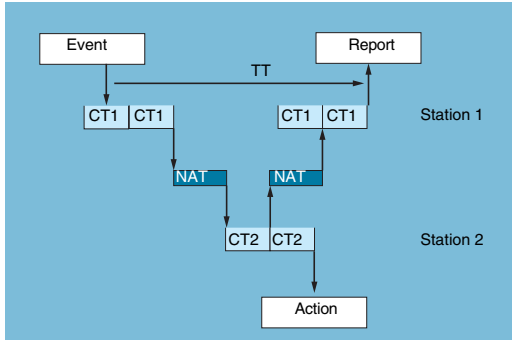

#### Application response time

##### Response time of Modbus (or Uni-TE) messaging handling service

PLC module processor exchanges are synchronous with the PLC cycle, in the same manner as the input/output exchanges. When an event appears, (input switching to 1 for example), a message can only be transmitted after this input has been taken into consideration (start of the following cycle) and the PLC program has been executed, i.e. approximately 1.5 cycles after the event has appeared.

Network access time (NAT) shown in the table below as ms, totals the module transit time and the delay before the message can be transmitted across the network.

Processing Modbus message requests	Premium Ethernet TCP/IP		Quantum Ethernet TCP/IP	
	TSX ETY 210 TSX ETY 110WS	TSX ETY 4103/5103 TSX WMY 100 TSX P57 10...57 50	140 NOE 771 01/111 140 CPU 113/311 ●● 140 CPU 434/534 1●	140 CPU 65 150/160 140 CPU 67 160
Network access time NAT	< 25 ms	< 10 ms	< 10 ms	< 10 ms

Transaction time TT includes the delay between the transmission of a message from a client station 1, its reception by a server station 2, processing the request, sending back the response and its acceptance by station 1 (update of an output for example). As the block diagram above shows:

- The duration of the transaction TT will be between:

$$2 \times CT1 + 2 \times NAT < TT < 4 \times CT1 + CT2 + 2 \times NAT$$

- Average duration  $TT_{ave}$  is:

$$TT_{ave} = 3 \times CT1 + 0.5 \times CT2 + 2 \times NAT$$

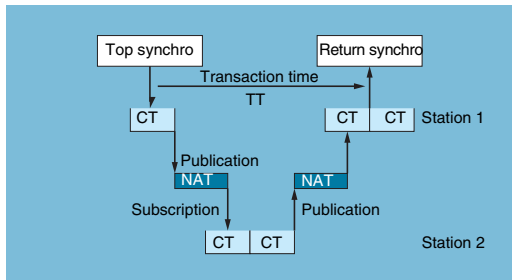

#### Response time of Global Data service

The transaction time (TT) includes the delay between publication of a Global Data by station 1, its reception and processing by remote station 2 and its retransmission to the initial station 1:

For an exchanged variable:

- If  $CT < 5$  ms, transaction time:  $TT = 5$  to  $6 \times CT$
- If  $CT \geq 10$  ms, transaction time:  $TT = 3 \times CT$

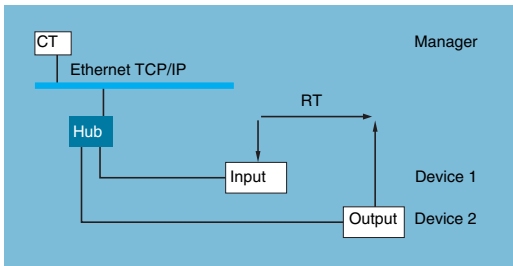

#### Application response time (continued)

##### Response time of I/O scanning service

The RT application response time includes the delay between getting data from a remote input and updating the remote output. It includes PLC application treatment time.

This RT response time is composed of following parameters:

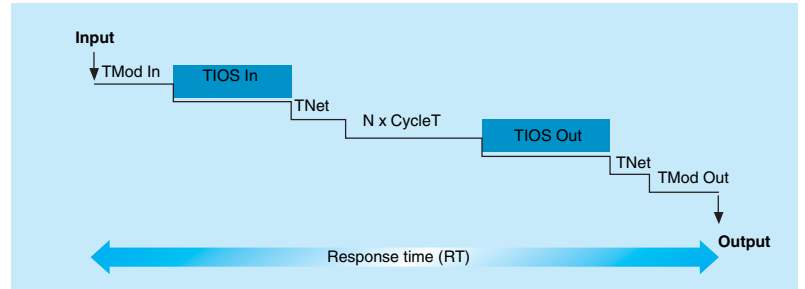

- TMod In and TMod Out: response time of the read/write device excluding the input circuit transition (TMod depends on the device, but commonly between 1 to 8 ms). For more details see table below.
- TIOS In and TIOS Out: time between two scanning cycles of the same read device (0.3 ms x number of devices scanned and at least the polling rate configured. TIOS is executed in parallel of the CPU cycle time, so could be hidden for the RT response time).
- N: number of PLC CPU cycles. For more details see table below.
- Cycle T: CPU cycle time.
- Tnet: propagation time on the network (depending of the application, but commonly Tnet is 0.05 ms at 10 Mbit/s and 0.005 ms at 100 Mbit/s).

The RT response time can be estimated using the following formulas:

■ RT<sub>min</sub>, minimal response time with TIOS hidden:

$$RT_{min} = (TMod In + 0) \times TIOS In + (Tnet + N) \times CycleT + (0 \times TIOS Out) + Tnet + TMod Out$$

■ RT<sub>typic</sub>, typical response time with 0,5 TIOS hidden:

$$RT_{typic} = (TMod In + 0.5) \times TIOS In + (Tnet + N) \times CycleT + (0.5 \times TIOS Out) + Tnet + TMod Out$$

■ RT<sub>max</sub>, maximal response time with TIOS not hidden:

$$RT_{max} = TMod In + TIOS In + (Tnet + N) \times CycleT + TIOS Out + Tnet + TMod Out$$

The TMod In and TMod out response time are shown below:

Discrete I/Os	Response time	Min.	Typical	Max.
Momentum 170 ENT 110 02	TMod In	1 ms	1 ms	1 ms
	TMod Out	5 ms	5 ms	5 ms
Momentum 170 ENT 110 01	TMod In or TMod Out	4 ms	6 ms	8 ms
Advantys STB STB NIP 2212	TMod In or TMod Out	2 ms	3 ms	4 ms

The TIOS In and TIOS Out times measured between two scanning cycles (network with switches) are shown opposite.

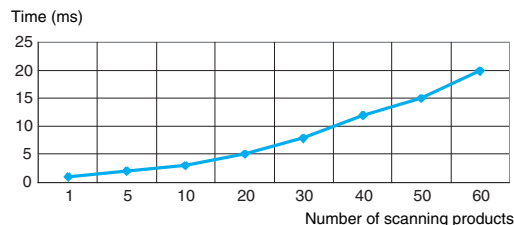

The number, N of CPU cycle times are shown below:

Number N of CPU cycles	Min.	Typical	Max.
Premium processors TSX P57 26/3634M and TSX P57 26/28/36/4823M	2	2.5	3
All Premium processors with TSX ETY 4103/5103 modules All Quantum processors with 140 NOE 771 01/771 11 modules	1	1	2
Premium processors TSX P57 46/5634M Quantum processors 140 CPU 651 50/60	1	1	2

# Transparent Ready® Products

## System approach

### Performance of Ethernet TCP/IP network

#### Processing capabilities of Premium and Quantum PLCs

##### Processing capacity

The table below compares the total number of messages received via the Modbus and Uni-TE service for each station (value R1, R2 or Ri) with the stations processor processing capacity.

Modbus request answered per Unity PLC scan

Premium or Atrium platform	Messages being received
<b>Communication by EFs or EFBs (PL7 or Unity Pro)</b>	
Total PLC messages from all communication modules (1)	TSX 57 10 4 mes/cycle
	TSX 57 20 8 mes/cycle
	TSX 57 30 12 mes/cycle
	TSX 57 40 16 mes/cycle
	TSX 57 50 (2) 16/20 mes/cycle

Quantum platform	Embedded port limitations		Communication modules limitations		Ethernet modules per PLC
	All type of communication request	Additional read or write 4x registers	All type of communication request	Additional read or write 4x registers	
140 CPU 113 (3)	–	–	1 mes/cycle	4 mes/cycle	Max. 2
140 CPU 311	–	–	1 mes/cycle	4 mes/cycle	Max. 2
140 CPU 434/534	–	–	4 mes/cycle	8 mes/cycle	Max. 6
140 CPU 651	16 mes/cycle	16 mes/cycle	4 mes/cycle	8 mes/cycle	Max. 6

mes/cycle: number of messages being received per cycle from the PLC master task (typical cycle from 50 to 100 ms).

Example:

Quantum 140 CPU 434 12● with 4 140 NOE 771 ●1 modules = 20 mes/cycle total for all type communication request and 32 mes/cycle total for read/write of 4x registers.

##### Ethernet connection processing capacity

For each station, compare the total number of messages received  $\Sigma$  [values Ri, Rj] and the total number of messages transmitted  $\Sigma$  [values Ei, Ej] for station N, for example) with the Ethernet network connection processing capacity shown below. Use the following as Ethernet connection per PLC rather than the number of transactions required by the application.

Processing capacity of Ethernet connections	Premium Ethernet TCP/IP			Quantum Ethernet TCP/IP	
	TSX ETY 110/210 TSX ETY 110WS	TSX ETY 4103/5103 TSX WMY 100 (4) TSX P57 10/20/30/40	TSX P57 50	140 NOE 771 01/11 140 NWM 100 00 (4)	140 CPU 65 150/160 140 CPU 67 160
Modbus messaging	60 transactions/s	450 transactions/s	500 transactions/s	350 transactions/s	350 transactions/s
Scanning I/O polling	Service not available	2000 transactions/s	2000 transactions/s	2000 transactions/s	2000 transactions/s
Global Data subscriptions		800 transactions/s	800 transactions/s	800 transactions/s	800 transactions/s

(1) A temporary overload on several PLC cycles, due to an adjustment terminal or the temporary connection of an Internet browser, is acceptable.

(2) Only with Unity Pro software.

(3) Only with Concept/ProWORX software.

(4) I/O Scanning and Global Data services are not available for TSX WMY 100 and 140 NWM 100 00 modules.



## Processing capabilities of Premium and Quantum PLCs (continued)

### Management of the Ethernet network module bandwidth

The bandwidth management service shows load level for the Ethernet module. This enables the user to monitor any drift and anticipate possible problems.

Ethernet module load is indicated in 3 ways:

- Anticipated load in the PL7/Unity Pro configuration screen
- Actual load in the PL7/Unity Pro diagnostics/debugging screen, as well as in Web diagnostics pages. The load is displayed as a bar graph, animated in real time
- In the SNMP interface for access to the SNMP network manager.

The bandwidth is shown as a percentage for each of the following services:

- Modbus (and Uni-TE) message handling
- I/O Scanning
- Global Data
- Other.

#### Presentation

The ConneXium Industrial Ethernet Offer is comprised of a complete family of products and tools required to build the infrastructure of an Industrial Ethernet network. In the following chapter summary information for the proper design of a network and the selections of its components is offered.

#### Office Ethernet versus Industrial Ethernet

There are three main areas of differentiation between Ethernet applications in an office environment and Ethernet applications in an Industrial environment, they are:

- Environment
- Layout (not physical layer specification)
- Performance

Contrary to the office environment and even though ISO/IEC is working on it, there are not yet clearly defined specifications for Ethernet devices targeted to Industrial applications. The specifications of what it is called Industrial Ethernet are defined by different agencies or entities based upon its nature and based upon what the automation market has traditionally used.

The environmental specifications of Industrial Ethernet devices are today defined by the traditional agencies that define the environmental specifications for standard industrial devices (UL, CSA, CE, ...).

The IEEE 802.3 defines the physical layer specifications of the Ethernet network (types of connectors, distance between devices, number of devices, ...) while the 11801 (similarly to the TIA/EIA 568B, and CENELEC EN 50173) provide installers the layout guidelines; therefore when designing an Industrial Ethernet network and selecting its infrastructure components the IEEE 802.3 rules for quantities of devices and lengths.

The performance specifications are actually being worked on by ISO/IEC.

#### Ethernet 802.3 principles

The Ethernet 802.3 Link Layer is based on a collision detection mechanism (CSMA CD): every node whose information has collided on the network realizes the collision and re-sends the information.

The process of re-sending information causes delays in its propagation and could affect the application.

A collision domain is a group of Ethernet end devices interconnected by hubs or repeaters (devices that receive information and send it out to all their other ports, no matter where the destination device is connected): it means that all devices will be affected by collisions.

With the availability of full duplex switches (devices that receive information and send it out just through the port to which the destination device is connected) the collision domains have disappeared.

Therefore, for industrial automation applications it is strongly recommended to use in every case full duplex switches to interconnect devices. In this way the collision domains will be eliminated completely.

#### Different network topologies

Next there is a description of some of the available network topologies.

#### Star topology

In a star topology, all devices are connected through an intermediate device.

##### Ethernet Star

In an Ethernet star the intermediate device may be a **hub** or a **switch**. Star is the commonly used topology in corporate networks and as of today is adopted in almost every automation application. As mentioned previously, for industrial Ethernet applications the use of full duplex switches as central device rather than hubs is strongly recommended.

##### Deploying Star topologies with ConneXium

With any of the hubs and switches offered by the ConneXium offer, star topologies can be implemented.

#### Bus topology

The bus is one of the most adopted topologies in traditional industrial automation networks. A single trunk cable connects all the devices on the network usually via passive or active T-connectors, or directly chained (daisy chain). Devices usually can be installed anywhere along the bus.

##### Ethernet Bus

An Ethernet bus can be deployed by interconnecting **hubs** and/or **switches** in line and considering every one of them as the connection for a drop device. A limited number of hubs and an unlimited number of switches can be interconnected to achieve this purpose.

##### Deploying Bus topologies with ConneXium

With any of the hubs and switches offered by the ConneXium offer bus topologies can be implemented. Specially suitable for this purpose are the switches with 1 or 2 fiber optic ports. The 2 fiber optic ports switches could be for connection of inline devices while the single fiber optic port switches could be used for the connection of end line devices.

#### Daisy chain topology

Daisy chain -along bus- is the other most adopted topology in traditional industrial automation networks. Cable segments interconnect multiple devices, being the devices "part" of the network cable.

##### Ethernet daisy chain

Daisy chain is not today a very common Ethernet topology, but it will soon become one of the most popular ones when enough quantity of devices is made available. In Ethernet daisy chain the devices have **2 Ethernet ports** and an **embedded switch**.

Schneider Electric is releasing to the Industrial market Industrial Ethernet devices to be connected in daisy chain architectures.

##### Deploying daisy chain topologies

To deploy daisy chain topologies, no hubs or switches are required. All devices have an embedded switch.

Dual port Ethernet at the device level is an absolute integral component for daisy chain topologies. Each device in the network has at least two Ethernet ports. One port of the device connects to one port of the neighboring device on either side of the device. These neighboring connections make up the daisy chain.

Ethernet switches can be employed in a daisy chain topology when multiple scan chains are in use by the controlling device. It is expected that the Ethernet switch will be located near the controlling device with the different scan chains emanating from the switch.

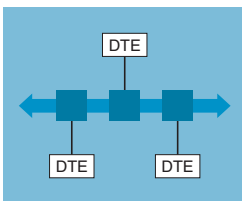
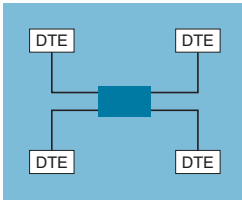

#### Daisy chain topology (continued)

##### Limitations of daisy chain:

Limitations of daisy chain to insure the operational integrity of the network and meet performance matrix, are:

- Dual port Ethernet devices only support 10 Mbit/s and/or 100 Mbit/s operational speeds and must use one or the other.
- The network will operate only as fast as the slowest device that is connected to the network
- In order to improve network traffic latency the numbers of devices in a single scan chain, has been limited to 32 devices.
- Limiting a single scan chain to 32 devices the time for a round trip of a packet through the daisy Chain is expected less than 5 milliseconds (with 32 devices plugged on a scan daisy chain).

The maximum packet latency of a packet passing through any device in a scan chain is no more than 10 µs.

The first Schneider Electric device with Ethernet daisy chain capabilities is the Lexium 17D servo drive, see page 83.

#### Ring topology

In a ring topology, all devices or network infrastructure components are connected in a loop with no beginning or end. Through these types of topologies a type of network redundancy is achieved.

##### Ethernet Ring

Ethernet rings are usually the backbones of applications in which high availability is required. If ring topology is required then switches that support this feature should be ordered.

##### Deploying Ring topologies using ConneXium.

The ConneXium line offers hubs and switches that allow the deployment of single and coupled self-healing rings. There is additional information about this topic in the redundancy segment.

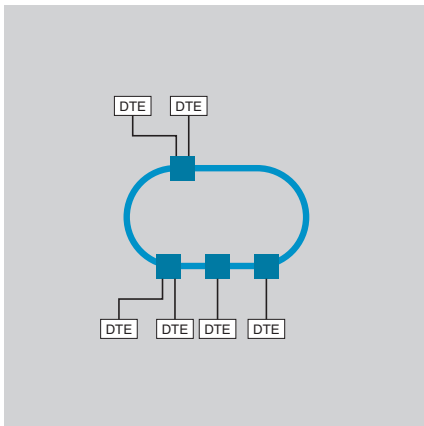

#### Distance limitations and number of devices per segment

Based upon the 802.3, the distance limits and the numbers of devices in cascade are the following:

Type	Maximum segment length (1)	Maximum segment length (offered by ConneXium devices)	Maximum number of hubs in cascade	Maximum number of switches in cascade
10BASE-T	100 m	100 m	4	Unlimited
100BASE-TX	100 m	100 m	2	Unlimited
1000BASE-T	100 m	100 m	–	Unlimited
10BASE-FL	2000 m	3100 m (2)	11 (fiber ring)	–
100BASE-FX	412 m/2000 m	4000 m with multimode, 32.500 m with monomode (3)	–	Unlimited
1000BASE-SX	275 m	–	–	Unlimited

(1) Based on 802.3, full duplex/half duplex.

(2) Depends on the optical budget and fiber attenuation.

(3) Depends on the optical fiber budget and fiber attenuation, typical specification is 2 km for multimode and 15 km from monomode.



## Physical Media

The Ethernet 802.3 defines the Physical Layer. A summary of the most common ones are shown below

Type	Data rate	Cable type		Connector type	
		Defined by 802.3	Recommended by Schneider Electric	Defined by 802.3	Recommended by Schneider Electric
10BASE-T	10 Mbit/s	CAT 3 - UTP	CAT 5E - STP	RJ45	RJ45
100BASE-TX	100 Mbit/s	CAT 5 - UTP	CAT 5E - STP	RJ45	RJ45
1000BASE-T	1 Gbit/s	CAT 5 - UTP	CAT 5E - STP	RJ45	RJ45
10BASE-FL	10 Mbit/s	Two multimode fiber optic cables typically 62.5/125 µm fiber, 850 nm light wavelength	Two multimode fiber optic cables typically 62.5/125 µm fiber, 850 nm light wavelength	ST	ST
100BASE-FX	100 Mbit/s	Two multimode optical fibers typically 62.5/125 µm multimode fiber, 1300 nm light wavelength	Two multimode optical fibers typically 62.5/125 µm multimode fiber, 1300 nm light wavelength	ST	SC
		–	Two monomode optical fibers typically 9/125 µm multimode fiber, 1300 nm light wavelength	–	SC
1000BASE-SX	1 Gbit/s	Two 62.5/125 or 50/125 multimode optical fibers, 770 to 860 nm light wavelength	Two 62.5/125 µm or 50/125 m multimode optical fibers, 1300 nm light wavelength	SC	LC
1000BASE-LX	1 Gbit/s	–	Two 9/125 µm monomode optical fibers, 1300 nm light wavelength	–	LC

*Nota : The above are the specifications defined by IEEE 802.3. However some of the cables are not longer being developed. For instance, for 10BASE-T as well as for 100BASE-TX the cable used is CAT-5e.*

## Management

The Ethernet devices in general (end devices and the cabling devices) devices may be divided in two categories: unmanaged and managed devices:

- **The unmanaged** devices are those which there is no possibility to configure or control any of the parameters of the device.
- **The managed** devices are those which there is possibility to configure or control the parameters of the device (manage them) and to access to its internal information.

The ConneXium product line offers both types of devices.

There is also a third category of devices not specifically defined but is important to understand the difference. These devices only allow access to its information but can not be controlled and/or configured. Usually these devices are considered in the category of managed devices.

**The managed devices** offer the following features:

- **Traffic optimization and filtering**, goal is to increase the bandwidth, or the traffic capacity in a network (some of the features in this area are message and port priority, flow control, multicast filtering, broadcast limiting, IGMP snooping, Vlan, etc.).
- **VLAN**, a virtual LAN (VLAN) consists of a group of network participants in one or more network segments who can communicate with each other as if they belonged to the same LAN.

VLANs are based on logical (instead of physical) links. The biggest advantage of VLANs is their possibility of forming user groups based on the participant function and not on their physical location or medium.

Since broad/multicast data packets are transmitted exclusively within a virtual LAN, the remaining data network is unaffected. VLAN can also serve as a security mechanism to block unwanted Unicast messages.

- **Security**, feature that helps the user protect the switch from unauthorized access that could result in changes in its configuration and impact the traffic going through the switch (some of the features in this area are port security, read/write community name, etc.).

User can also set up the switch so that it blocks messages coming from unauthorized “devices” source addresses connected to the switch.

- **Time Synchronization**, feature that allows all the devices in the network to be synchronized on time.
- **Network Redundancy**, to develop high availability applications.
- ...

#### Redundancy

To develop high availability applications, “redundancy” in the networking infrastructure is the answer. By implementing a single ring architecture, or a coupled ring one, can protect themselves against losses of network segments.

#### Single Ring

The first level of redundancy is achieved by implementing a single ring. The **499 N●S 271 00** ConneXium switches allow the set up of backbone ring configurations.

The ring is constructed using the HIPER-Ring ports (6 and 7). If a section of the line fails, a ring **structure of up to 50 Switches** transforms back to a line-type configuration within 0.5 seconds.

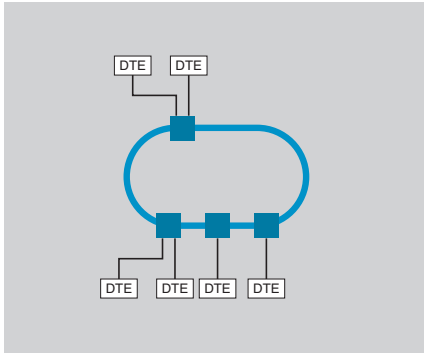

#### Dual Ring

The second level of redundancy is achieved by implementing a dual ring. The control intelligence built into the **499 N●S 271 00** ConneXium switches allows the redundant coupling of HIPER-Rings and network segments.

These configurations would double the redundancy obtained by using a single ring.

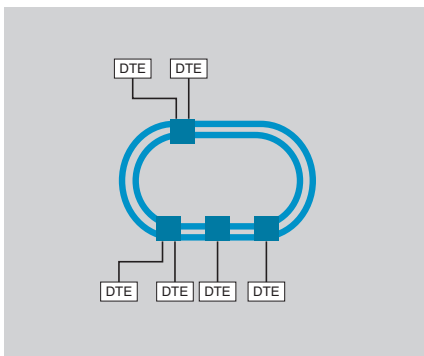

#### Mesh topology using the Rapid Spanning Tree protocol

**A third level of redundancy can be achieved by implementing a mesh topology.** In simple terms spanning tree is a protocol that ensures a single path for the signal, when multiple paths exist, and if the active path is broken, the spanning tree protocol enables one of the alternatives paths.

The **499 N●S 271 00** ConneXium switches offer the possibility.

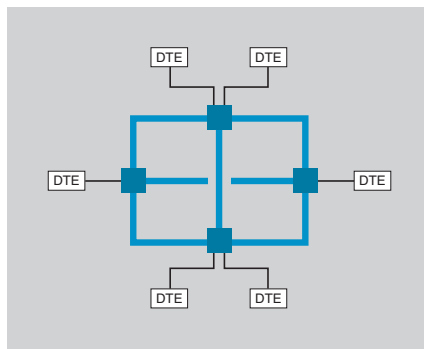

#### Industrial Cabling devices selection guidelines

The following are high level guidelines for the selection of the right cabling devices

<b>General recommendation</b>	<ul style="list-style-type: none"> <li><input type="checkbox"/> Use switches to eliminate collisions, increase performance and simplify network design. Avoid using Hubs whenever possible</li> <li><input type="checkbox"/> Understand network traffic and segment network properly</li> </ul>
<b>For networks in which high bandwidth availability is required</b>	<ul style="list-style-type: none"> <li><input type="checkbox"/> Use full duplex switches (10BASE-T/100BASE-TX)</li> <li><input type="checkbox"/> Understand network traffic and segment network properly</li> </ul>
<b>For applications in which minimum application downtime is required</b>	<ul style="list-style-type: none"> <li><input type="checkbox"/> Use self-healing ring or redundant self healing ring</li> </ul> <p>Reference: <b>499 NoS 271 00</b></p>
<b>For networks that require basic level diagnostic</b> (e.g no Link or failure of one P/S)	<ul style="list-style-type: none"> <li><input type="checkbox"/> Use unmanaged switches with alarm relay</li> </ul> <p>References: <b>499 NoS 251 01</b>, <b>499 NoS 251 02</b> and <b>499 NES 181 00</b></p>
<b>For networks that require high level services and traffic administration</b>	<ul style="list-style-type: none"> <li><input type="checkbox"/> Use managed switches</li> </ul> <p>Reference: <b>499 NoS 271 00</b></p>
<b>For applications that require network discovery and monitoring</b>	<ul style="list-style-type: none"> <li><input type="checkbox"/> Use managed switches</li> </ul> <p>Reference: <b>499 NoS 271 00</b></p>
<b>For applications that require interconnecting devices separated by long distances (&gt; 100ms)</b>	<ul style="list-style-type: none"> <li><input type="checkbox"/> Use fiber optic products</li> </ul> <p>Multimode fiber: Up to 2 km between nodes          Monomode fiber: Up to 15 km between nodes</p> <p><i>Nota : Depending on the fiber and optical budget could reach 4 km on multimode and 30 km on monomode (see distances in this chapter)</i></p> <p>Reference: <b>499 NoS 251/ 271●●</b></p>
<b>For networks that require high immunity to electromagnetic noise</b>	<ul style="list-style-type: none"> <li><input type="checkbox"/> Use products with fiber optic ports</li> </ul> <p>Reference: <b>499 NoS 251/ 271●●</b></p>
<b>For applications that require physical medium change</b>	<ul style="list-style-type: none"> <li><input type="checkbox"/> Use transceivers or use switches with a combination of copper and fiber optic ports.</li> </ul>
<b>For applications that require external (IP 67) mounting of the switch</b>	<ul style="list-style-type: none"> <li><input type="checkbox"/> Use IP 67 switches and cables</li> </ul> <p>Reference: <b>TCS ESU 051 F0</b></p>
<b>Cabling components, the following are high level guidelines for the selection of the right cables and connectors</b>	
<b>For 10BASE-T / 100BASE-TX networks ("copper" networks) in IP 20 environment</b>	<ul style="list-style-type: none"> <li><input type="checkbox"/> Use STP (Shielded Twisted Pair) Cat5e cable (based on TIA 568B) - 4 pairs or 2 pairs</li> <li><input type="checkbox"/> Verify jacket specifications to be suitable for IP 20 environment</li> <li><input type="checkbox"/> Use RJ45 connectors</li> </ul>
<b>For 100BASE-FX networks ("fiber" networks) in IP 20 environment</b>	<ul style="list-style-type: none"> <li><input type="checkbox"/> Use multimode or monomode fiber optic</li> <li><input type="checkbox"/> Verify jacket specifications to be suitable for IP 20 environment</li> <li><input type="checkbox"/> Use SC connectors</li> </ul>
<b>For 10BASE-T / 100BASE-TX networks ("copper" networks) in IP 65/67 environment</b>	<ul style="list-style-type: none"> <li><input type="checkbox"/> Use STP (Shielded Twisted Pair) Cat5e cable (based on TIA 568B) - 2 pairs</li> <li><input type="checkbox"/> Verify jacket specifications to be suitable for IP 65/67 environment</li> <li><input type="checkbox"/> Use M12 D coding 4 pins connectors</li> </ul>
<b>For 100BASE-FX networks ("fiber" networks) in IP 65/67 environment</b>	<ul style="list-style-type: none"> <li><input type="checkbox"/> Use multimode or monomode fiber optic</li> <li><input type="checkbox"/> Verify jacket specifications to be suitable for IP 65/67 environment</li> <li><input type="checkbox"/> Use SC connectors</li> </ul>

#### Transparent Ready Power Equipment

The application of Transparent Ready in electrical distribution power equipment is based on the concept of the Transparent Ready Power Equipment offer.

This is an optimized architecture in which the Transparent Ready services are mutualized within the EGX gateway, while providing communicating products built into the electrical equipment (switchboard) with transparent connectivity for any Modbus client on TCP/IP.

Once the parameters of the EGX gateway have been set, the user therefore has the benefit of very simple (see below) ready-to-use functions such as:

- The display of summary pages on instantaneous measurements and the status of the electrical equipment.
- The display of detailed electrical data on all circuits (rms current (A), actual power (kW), power factor, active and reactive powers, etc).
- The logging of standard data, power, trends, etc.
- The display of logs.
- Exporting data tables in standard Windows format.

The Web server embedded in the electrical equipment does not interfere with the Modbus communication flows from the Modbus clients on the Ethernet network.

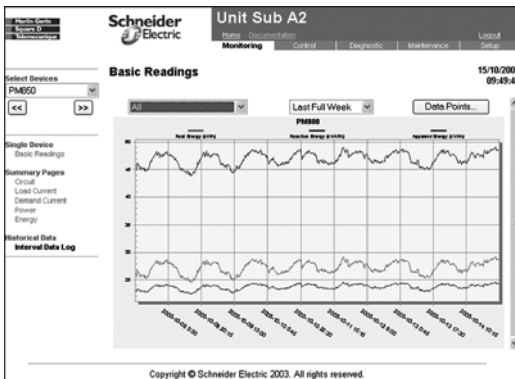

#### Web Page Generator (WPG)

The Web Page Generator is a software tool for creating Web pages, designed for the commissioner of the Transparent Ready Power Equipment. Its purpose is the automatic creation of Web pages, according to the actual configuration of the electrical switchboard.

It includes a library of electrical distribution and motor control products such as:

- PM 800/500 power meters.
- Micrologic digital protection relays (Masterpact).
- Sepam 2000 and Sepam 20/40/80 digital protection relays.
- CM 3000/4000 circuit monitors for measuring and analyzing power quality.

The Web Page Generator software also supports:

- Motorlogic Plus relays, Motorpact medium voltage motor controllers (Trademark Square D).
- TeSys model U starter controllers, ATV 31/58/68 Altivar variable speed drives, ATS 46/48 Altistart soft starters (Trademark Telemecanique).

It automatically creates the corresponding Web pages for each of the products connected on the Modbus (SL) serial link built into the electrical equipment and declared by the installer. It also automatically produces summary pages, providing the operator with an overall view of the status of his equipment. It also integrates an FTP client in the EGX gateway, which authorizes the immediate downloading of the HTML pages that have been created.

The level of knowledge required to carry out these operations has been set at a deliberately low level.

The operating mechanisms of the Web pages created in this way are described on page 70. The HTML pages produced are standard format which can be edited further if necessary, using standard word processing or HTML tools.

#### Mechanism for dynamic reading via the Web

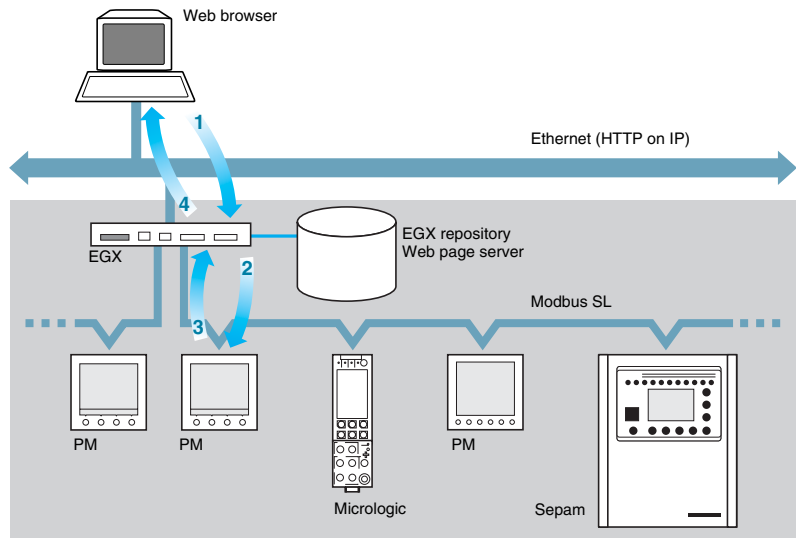

Schneider Electric Unit Sub A2 Monitoring

10.15.2003 09:45:04

Circuit Summary

Transformer	PhA	PhB	PhC	Fault Status
Model 99	33	33	32	OFF

Circuit	RMS Current (Amps)	Real Power (kW)	Power Factor	Breaker Status
Type P	268	89	1.00	closed
CM2450	95	74	0.88 lag	---
CM2000	425	1490	0.48 lag	---
CM4000-4	22	9	0.93 lag	---
CM4000-40	118	42	0.98 lag	---
Sepam M41	409	-6723	-0.5	---
Sepam S20	274	---	---	closed
PM650	0	0	1.00	---
PM650	69	-8	0.32 lag	---
PM650	55	12.39	0.59	---
PM650	82	-45540	-0.83	---
PM650	222	115	0.59 lag	---
Energy Meter	1.07	0.08	0.83	---

Copyright © Schneider Electric 2003. All rights reserved.

The EGX gateway uses HTML language for serving the Web pages containing dynamic values associated with the products on the Modbus SL link, and is thus compatible with all Web browsers. This mechanism is totally transparent for the user.

When HTML pages are created, each dynamic data location in the page causes a “<PL>tag” to be inserted which specifies the characteristics of the Modbus service required for finding the value of this variable, as well as presentation data for this variable (Modbus function code, Modbus address, register number, LSB order, unit). When the Web page is viewed (action 1, reception of an HTTP request from the Web client), the EGX gateway analyzes the contents of the requested Web page, detects any “<PL> tags”, then executes the Modbus services required for reading the dynamic variables (actions 2 and 3), fills in the HTML page accordingly and sends it all back as if it were a static page (action 4). The HTML page is displayed on the browser screen.

The page is automatically updated by the browser every 5 seconds.

#### Transparent access mechanism via Modbus messaging

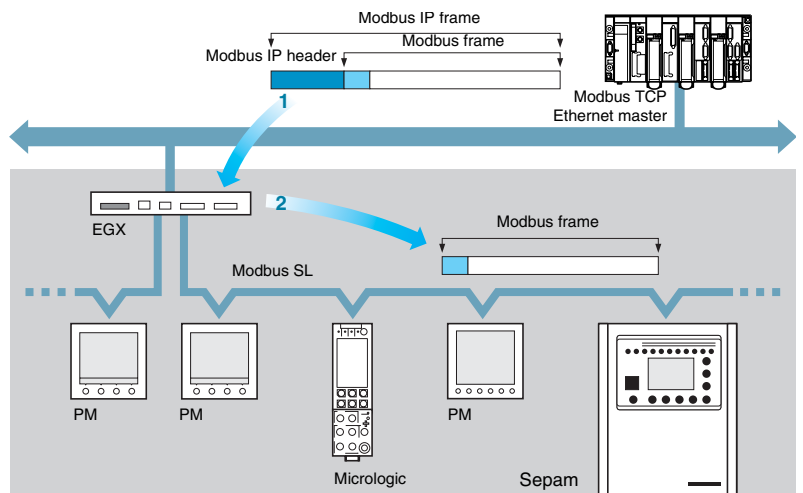

When accessing product data on the Modbus SL link, via Modbus messaging, the gateway has no added value other than translating addresses, encapsulating and unencapsulating Modbus frames, whatever function code is used (transparent data access).

The gateway thus provides products on the Modbus SL serial link with the Ethernet pass band and a multi-master operating capability. The latter function is also effective when the Modbus master is connected directly to one of the two Modbus SL ports on the EGX gateway (configured this way).



Prisma Plus iMCC switchboard



Okken iMCC switchboard

#### Presentation of the dedicated iMCC approach

**iMCC (Intelligent Motor Control Center)** control switchboards are low voltage switchboards dedicated to energy distribution, as well as control and protection of motors. They are used in continuous and semi-continuous processes, in which it is necessary to group the motor starters together in one place for operational and maintenance reasons.

The Schneider Electric switchboard systems (Prisma Plus, sold under the Merlin Gerin brand, and Okken, sold under the Schneider Electric brand) provide an optimized solution for mounting motor starters:

- Complete, fully-tested mounting kit providing the correct thermal, electrical and mechanical (protection, access) environment for the components and equipment
- Optimized stacking density, up to 48 starters per column
- Wide range of mounting types: fixed, disconnectable and removable.

#### Integration of motor starters in iMCC switchboards

iMCC control switchboards make the work of operation and maintenance teams easier by improving the availability of the process, via:

- Control of motor starters using wire-to-wire cabling or via remote I/O located as close as possible to the starters and connected on the network
- Protection of the motors using an intelligent electronic protection relay. This provides more precise protection of the motors (analysis of operating conditions and alarm thresholds before tripping, etc).

These two functions can be grouped together in a single product, the electronic protection module. In this case, the protection relay module manages and transmits all this control and protection information directly.

#### Advantages of iMCC switchboards

iMCC control switchboards provide a high level of process availability while ensuring the safety of property and personnel. This solution decreases the number of process stoppages and their duration, reduces maintenance, reduces and repairs costs and optimizes process productivity:

- Reduction of process stoppages as a result of detailed alarms and diagnostics that enable staff to react before the motor starter trips, or react more quickly if it does trip
- Rapid diagnostics due to the availability of more detailed information on the stoppage conditions
- Analysis of stoppage logs using statistics from the electronic protection module.

iMCC control switchboards make installations easier to create, by reducing engineering and debugging time:

- Rapid parameter-setting as a result of local or remote downloading
- Analysis of phenomena via alarms, detailed diagnostics and stoppage logs (statistics embedded in the electronic protection module).

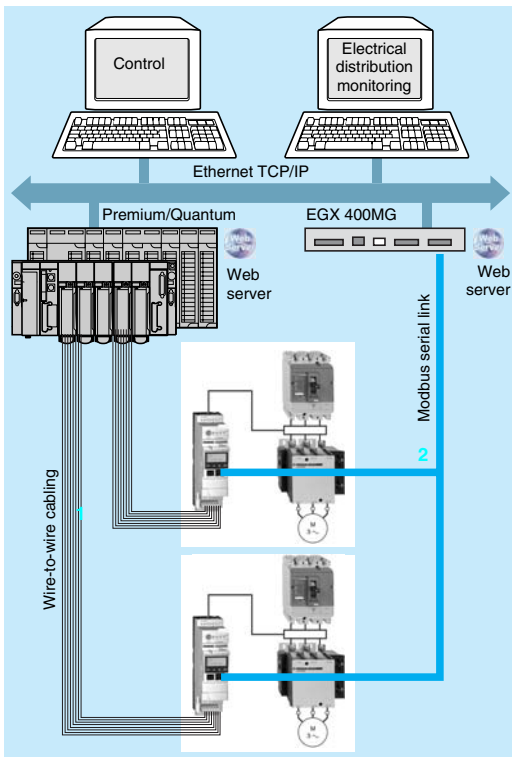

### iMCC switchboards with wire-to-wire TeSys model U motor starters and embedded Web server

In this architecture the TeSys model U motor starters are connected:

#### To the process control system 1

TeSys U motor starters are connected using a wire-to-wire link to a PLC or a controller providing maximum availability of the installation. Only the information necessary for control is wired.

#### For monitoring and diagnostics of Electrical Distribution 2

The TeSys model U motor starters (1) are connected via a Modbus serial link to an EGX gateway/server (see page 92). This connection make available on Ethernet TCP/IP, all information available on the TeSys model U intelligent motor starter, thus improving diagnostics and optimizing availability.

This information can be accessed locally or remotely by authorized persons only, for example an electrical installation manager, on any PC that has a simple Web browser.

This solution offers the following advantages:

- The amount and relevance of the information, provided at minimal cost
- No need for a user license on the client station (PC), and ease of use.

### iMCC switchboards with prewired TeSys model U motor starters and embedded Web server

In this architecture the TeSys model U motor starters are connected:

#### To the process control system 3

Each TeSys model U motor starter is connected by a dedicated LU9 R●● or 490 NTW 000 ●● cable to an Advantys STB automation island equipped with STB EPI 2145 parallel interface modules.

Each Advantys STB EPI 2145 module can be used to connect up to 4 TeSys model U controller-starters, each represented by 3 discrete inputs and 2 discrete outputs. The STB EPI 2145 module takes TeSys model U motor starters in non-reversing or reversing configuration.

This solution has the advantage of reducing wiring and thus the inherent risk of faults. It also enables control systems to be connected to a Transparent Ready architecture via the Advantys STB Ethernet TCP/IP network interface module, STB NIP 2212 (see page 98). This module is easy to replace in the event of a fault using the FDR replacement service (see page 39).

Connection to other networks or fieldbuses is also possible via Advantys STB network interface modules (CANOpen, Modbus Plus, Fipio, Profibus DP, INTERBUS, or DeviceNet).

#### For monitoring and diagnostics of Electrical Distribution 4

This is carried out, in a similar way to the wire-to-wire architecture above, via Modbus serial link to an EGX gateway/server in order to make all the information concerning the TeSys model U motor starters available, using Web pages.

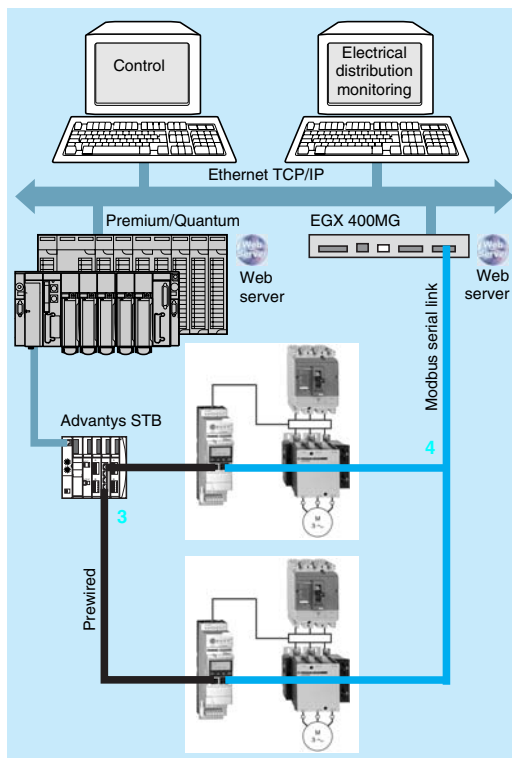

### Okken iMCC switchboards with Eagle motor protection system

Eagle is an intelligent motor protection system for critical processes, in particular in the chemical and petrochemical industries. It is installed in Okken, a high dependability switchboard, and is available from Schneider Electric referenced partners.

The Eagle system consists of:

- A relay card to protect the motors, and monitor and control the starters and incoming electrical distribution feeders
- A support for installing 12 or 24 relay installed in the cable duct in order to avoid accidental temperature rise and interference. This solution also enables the cards to be replaced without stopping communication, saves and automatically reloads the parameters of the relay cards when they are replaced
- Bus and power supplies that can be redundant (2 ports per relay)
- A software package for rapid programming of the data concentrator PLC and designing the embedded server Web pages.

(1) To be equipped with multi-function protection unit LUC M●●BL. These protection unit is connected to Modbus serial link.

## Modicon Quantum Hot Standby on Ethernet TCP/IP

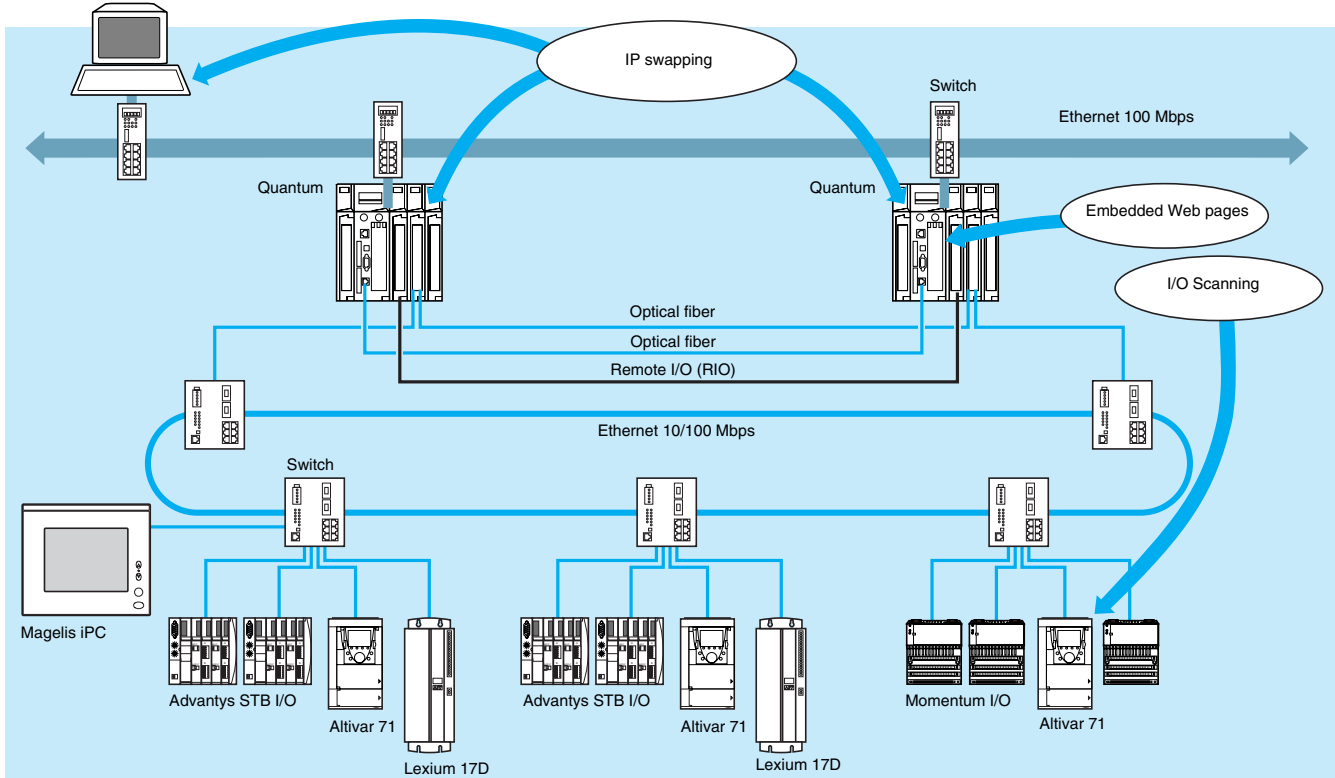

### Presentation

The Hot Standby option enables the Modicon Quantum automation platform to meet the needs of the most critical applications in terms of operating safety and availability. The main element of the system is a second PLC referred to as the “Standby”, configured to be identical to the “Primary” PLC and in standby mode. The Standby PLC uses a special high speed fiber optic link and the RIO link for redundancy, to constantly monitor the status of the Primary PLC. If there is a fault on the Primary PLC, the system automatically controls the changeover to the Standby PLC.

For less critical applications an Ethernet TCP/IP configuration could be used instead of using a Remote I/O (RIO) network and I/O drops (1). As both PLCs (Primary and Standby) simultaneously scan the same devices distributed on Ethernet TCP/IP using the I/O Scanning service, the process controlled by these devices is not affected by the fault in the control system. Likewise, the “IP swapping” function for automatically transferring the IP address from the Primary to the Standby makes the changeover from one PLC to the other transparent from the supervision PCs and HMIs.

Two types of Ethernet modules can be used in Quantum Hot Standby configurations: **140 NOE 771 01** and **140 NOE 771 11**, however the failure of one them is not automatically detected.

The Ethernet TCP/IP Web and communication services on these modules (Modbus messaging, Global data, FTP/TFTP, SNMP, HTTP, etc) are available in Hot Standby configuration, apart from the DHCP server providing the FDR (*Faulty Device Replacement*) service.

(1) Please consult our “Modicon Quantum automation platform and Unity, Concept & ProWORX” catalog.



#### Modicon Quantum Hot Standby on Ethernet TCP/IP (continued)

##### Cyclic transfer of the application context

At the start of each scan cycle, the content of the data memory in the “Normal” PLC is transferred to the “Standby” PLC via the fiber optic link, at the same time as the content of the tables that are images of the input and output states. The Hot Standby system is thus able to transfer all the 128 Kb made available to receive the located variables (RAM State) from the “Normal” PLC to the “Standby” PLC. As far as unlocated application variables are concerned, and also application data such as DFB instance data, for example, not less than 512 Kb can be transferred.

The principle of exchanges, as well as exchange times according to the volume of data, are described in the diagram below.

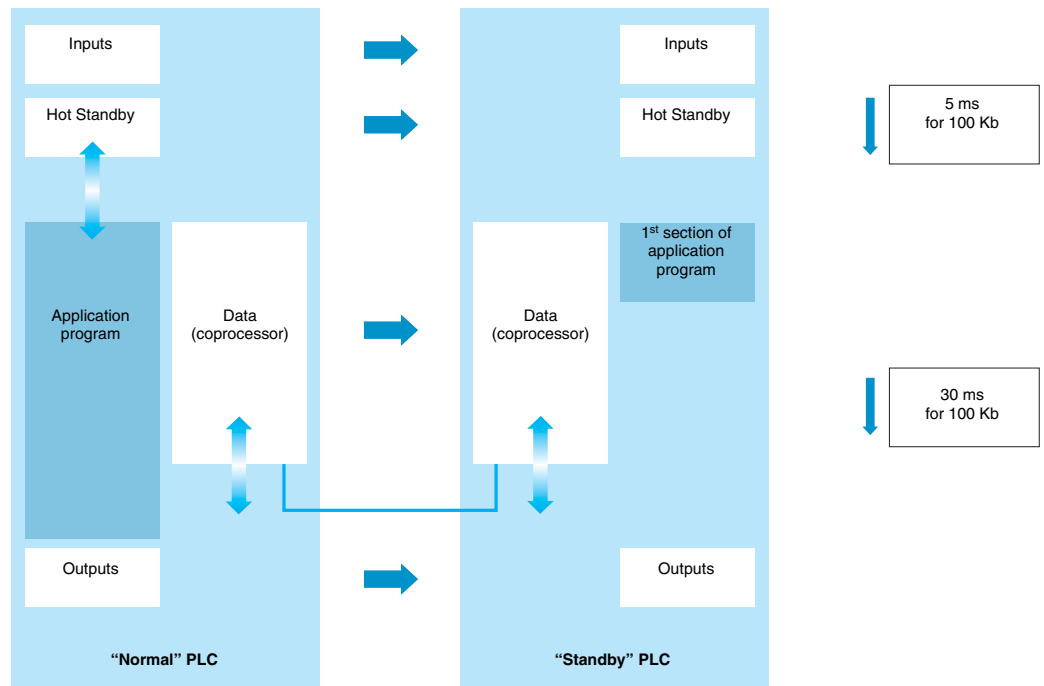

##### Operation on changeover

If there is a changeover from the Primary to the Standby PLC, the “IP swapping” function automatically assigns the IP address of the Ethernet **140 NOE 771 01/11** module of the Primary PLC to the Ethernet **140 NOE 771 01/11** module of the Standby PLC making the changeover transparent from the supervision PCs and HMIs.

After having closed the current client and server connections on Ethernet, each 140 NOE module sends a UDP changeover message to the 140 NOE module in the other PLC. The **140 NOE 771 01/11** module that sent the message then waits for the response from the other **140 NOE 771 01/11** module for a “Time-out” of 500 ms. As soon as the message is received or after this “Time-out”, the **140 NOE 771 01/11** module changes its IP address.

Likewise, the changeover is transparent when seen from the process. The most recent versions of distributed I/O on Ethernet TCP/IP have a function for maintaining the status of the outputs if there is a break in communication, thus when there is a changeover from one PLC to the other.

To avoid any communication problems, it is recommended that Ethernet **140 NOE 771 01/11** modules in Hot Standby configurations are connected on switches rather than on hubs (for further information on these products see the “Cabling system” section, page 54).

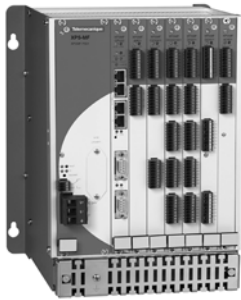

XPS MF modular Safety PLC



XPS MF compact Safety PLC



XPS MF remote I/O module

#### Presentation

The Safety PLC is a programmable logic controller designed to monitor safety functions up to Category 4 according to EN 954-1, and SIL 3 according to IEC 61508. The Safety PLC range is extensive and is able to cater to the needs of all end users.

The range is split into two parts composed of a modular Safety PLC system, and a range of compact Safety PLCs. The range alone would not be complete without an extensive range of remote Input/Output modules, which allow the expansion of the Master Safety PLCs providing more input/output terminals for all applications. The Safety PLCs have a red color housing shows the user that the product is part of the Preventa Safety range, and have an overall ingress protection rating of IP 20. The Safety PLC range are extremely versatile products and can be used in all areas of a factory floor.

#### Local I/O on safety PLCs

The Safety PLC device contains Input/Output terminals to which actuators, sensors, and signalling equipment can be attached:

- The discrete, analog or counter inputs are connected to limit switches, lever-operated switches, light guards, safety mats, emergency stops, two-hand control stations, incremental encoders, 2/3 wire sensors, and many other devices
- The discrete outputs are connected to illuminated beacons and indicator banks, lamps with rotating mirrors, sirens, circuit breakers, motor starters, power contactors, etc.

#### Distributed I/O dedicated to the safety PLCs

As well as the I/O that are integrated as standard, safety PLCs can take additional remote I/O modules. These modules can be placed closer to the application areas of the machines being monitored, and thus increase the I/O capacity of the safety PLCs.

The compact PLCs and remote I/O modules communicate on the SafeEthernet network via special communication ports (connected with RJ45 connector).

SafeEthernet communication can take place on a dedicated Ethernet segment as shown below. As SafeEthernet communication is based on Ethernet TCP/IP, all standard Ethernet devices can be used such as routers, switches. Other standard TCP/IP services, which can also be, provided over SafeEthernet, in parallel with other communication are:

- Web services
- Modbus TCP/IP messaging
- Communication between Preventa Safety PLCs and an automation platform such as Modicon Premium.

There are many benefits of using SafeEthernet protocol but by far the most important benefit lies in the protocols ability to communicate Safe and Standard data over one communication medium. This allows the user to reduce the overall costs for cabling and commissioning. End users will already be very familiar with the communication medium as it is widely used in the Information Technology sector, and many other specialized applications areas. Using the Standard grade Ethernet cable (category 5D) enables the users to connect Safety PLCs and remote I/O modules together with an overall separation of 100 m between any two nodes. The separation distance between any two nodes (modules) can be increased using fibre optic cable to over 80 km.

#### Safety PLC operation

Safety PLC modules incorporate 3 functions in order to meet Safety requirements:

- **Redundancy:** the double processor integrated within the Safety PLC analyses and compares the data received from the Safety inputs and reacts accordingly when sending data to the output terminals. The incoming and outgoing data (programmed values and received values) is received in parallel by both processors and compared in real-time. If the comparison between the two processors results are not equal then the Safety PLC system will automatically respond in such a way as to make all output signals return to their safe "off" state
- **"Watchdog" or Self-monitoring:** Safety PLCs continuously monitor the data processing cycle and the task execution procedure, and intervene if a cycle time does not comply with the cycle time set by the user. This enables the system to ensure stability preventing the processor from running very long processing cycles. This is very useful when the Safety PLC system is involved with time critical applications, such as with Emergency stop control.

#### Safety PLC operation (continued)

■ The Special Switch: stores the information received from the I/O for a very short period of time, whilst establishing a connection on the SafeEthernet network. Once a connection is established the SafeEthernet protocol determines whether to send the data in the Full-duplex mode or in Half-duplex mode. This is dependent on the network load at the time when the Safety PLC requires the transmission. When the connection is established it enables the system to send the data packet to the host without risk of a collision occurring, and thus preventing data loss. This also prevents congestion on the network, as signals need not be sent more than once. This enables the system to be deterministic due to the prevention of packet loss, and real-time ability of the system is due to the use of switches enabling the transmission times over SafeEthernet to be clearly defined. The transmission speeds over SafeEthernet at Full Duplex mode is 10 Mbit/s and in Half Duplex mode is 100 Mbit/s, with auto-negotiation.

#### Functional diagram

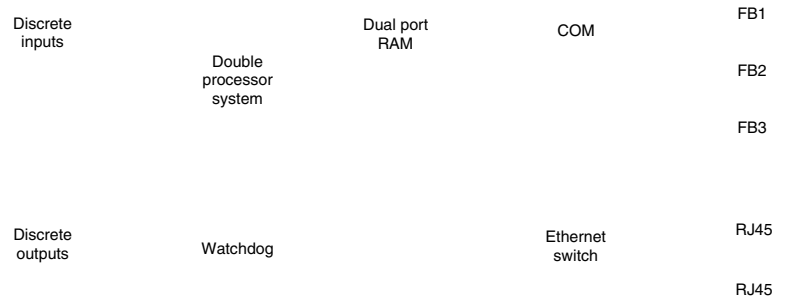

#### Communication on the SafeEthernet network

Communication over SafeEthernet is carried out using Ethernet cable category 5D or better. The Safety PLCs have either 2 or 4 RJ45 connections available (dependant on model) for connecting to the network. The Remote I/O modules have 2 RJ45 connections available for connecting to the network. The network topology can be connected as either a line or star configuration. The flexibility of the network structure enables the Safety PLC devices to be connected in any order required by the user. Therefore a master Safety PLC does not have to be directly connected to its remote I/O modules, but can be done indirectly through the other Safety PLCs on the network. The PC running **XPS MFWIN** can also be attached at any point within the network, which enables programming, and all diagnostic data to be obtained.

#### Connection on the SafeEthernet network

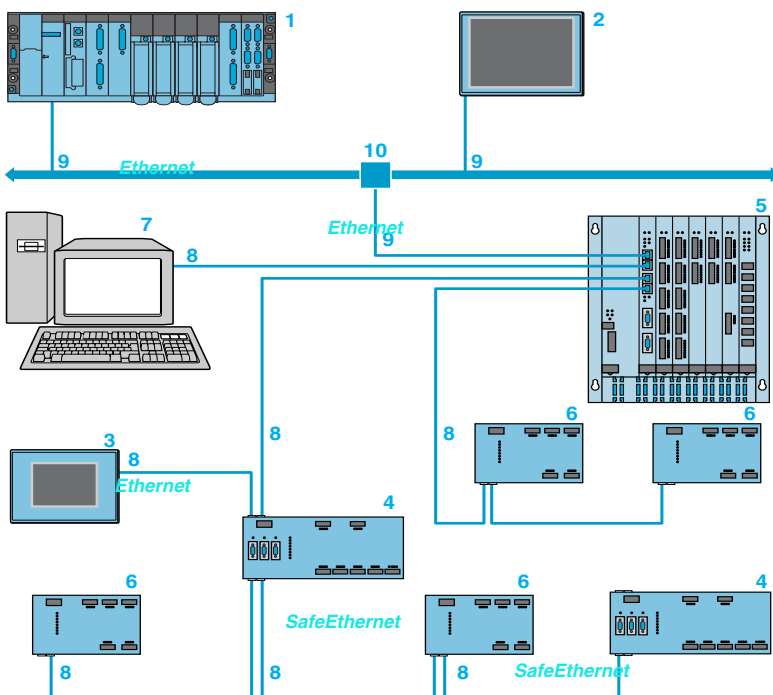

- 1 Premium **TSX P57 ●634M/●623M** processor or **TSX ETY 4103/5103** module on Premium automation platform, master on Ethernet network.
- 2 Graphic supervision terminal **XBT G5230**.
- 3 Graphic control terminal **XBT G2130**.
- 4 Preventa compact **XPS MF30/31/35** or modular **XPS MF60** PLCs.
- 5 Remote I/O modules **XPS MF1/2/3**.
- 6 PC for programming.
- 7 Straight shielded twisted pair cables **490 NTW 000 ●●**, in 5...80 m lengths.
- 8 Crossed shielded twisted pair cables **490 NTC 000 ●●**, in 2...80 m lengths.
- 9 Hubs **499 NEH 104 10**.

↕ Connection of safety sensors and actuators.

#### Presentation of integration into architectures

Transparent Ready industrial products can be integrated into architectures based on the universal Ethernet TCP/IP network, with no need for any interface. The basic architecture below shows the various communication levels and functions required by industrial applications to meet data exchange requirements:

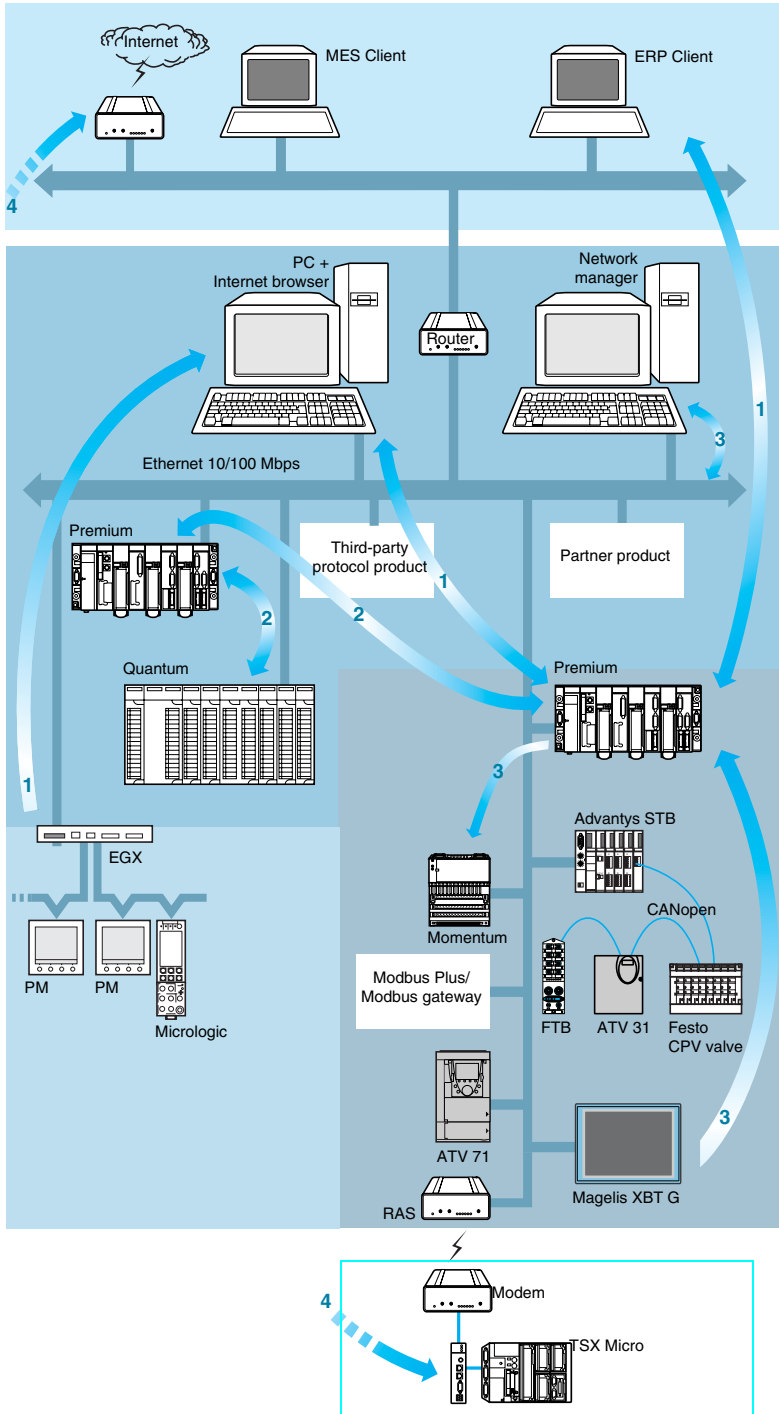

- 1 Company level: Communication between the control system products and the MES (Manufacturing Execution System) or ERP (Enterprise Resource Planning) supervision or information systems.
- 2 Inter-PLC level: Communication to PLCs for programming, diagnostics and data transfer, as well as communication between PLCs for synchronizing applications.
- 3 Field level: Communication between PLCs, PC and field devices.
- 4 Transparent remote communication: Remote communication via the Internet, or via telephone or radio link.

For a complete approach, the following requirements must also be taken into account:

- System diagnostic services
- Interoperability with third-party products or protocols
- Ethernet TCP/IP network security.

The various communication requirements of the architecture are summarized below in order to:

- Present the data exchanges required by each level
- Choose the Transparent Ready services and standard solutions on Ethernet TCP/IP that are most appropriate for each type of communication.

## 1 Company level

### Communication between MES/ERP system and PLCs

The requirements at this level are for communication using standard infrastructure and protocols for exchanging high volumes of data with production management systems. In some cases, the PLC must be able to adapt to the protocol specific to the connected system. Response times are not critical.

The Transparent Ready services used are mainly:

- HTTP communication, displaying data and sending commands via Web pages
- Data exchange using the OPC (OLE for Process Control) standard via an OFS data server
- Modbus TCP/IP messaging
- TCP Open
- E-mail transmission
- Direct publication in relational databases (via the FactoryCast HMI active Web server)
- SOAP/XML web services.

### Communication between SCADA systems and PLCs

For this type of communication, it is also necessary to transfer high volumes of data to a group of PLCs.

The required response times are in the region of 0.5 to 2 s.

The following Transparent Ready services are used:

- Mainly data exchanges using the OPC standard via an OFS data server
- Modbus TCP/IP messaging
- TCP Open
- HTTP communication integrated in the supervision system, for displaying Web pages from the field devices in supervision pages.

### Communication between HMI application and PLCs/field devices

A basic HMI (Human/Machine Interface) application must allow maintenance personnel to be notified of an event and to view the status of a field device.

The Transparent Ready services used are:

- Notification of events by e-mail
- Display of data and sending commands via Web pages.

## 2 Inter-PLC level

### Communication for data transfer

When data is sent in point-to-point mode according to PLC programming algorithms and the required response times are in the region of 200 ms to 1 s, the main Transparent Ready service to be used is Modbus TCP/IP messaging.

### Inter-PLC communication for synchronizing applications

Broadcast communication must enable several applications to be synchronized via real-time exchanges. In this case a low volume of data is exchanged.

The required response times are in the region of 10 to 500 ms.

The Transparent Ready Global Data service is particularly suitable for this type of data exchange.

### 3 Field level

#### Communication between PLCs and field devices for controlling the automation process

PLC applications are essentially responsible for controlling the I/O of peripheral devices. Data must be transferred to all devices quickly and repetitively. The required response times are in the region of 10 to 100 ms. The Transparent Ready I/O Scanning service meets these requirements.

#### Communication with field products Modbus

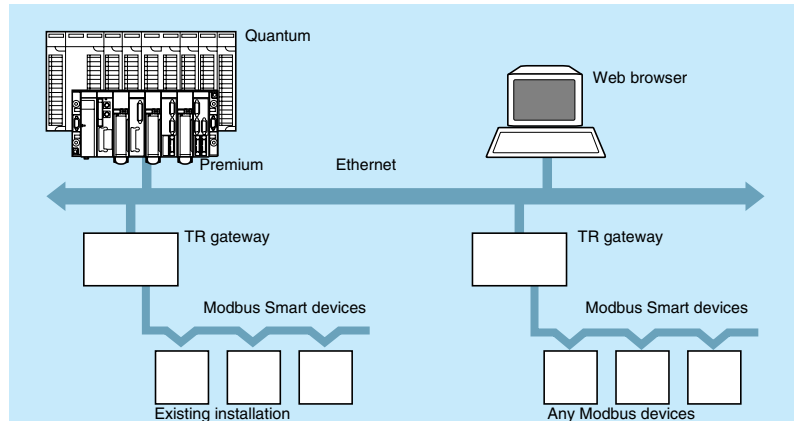

Modbus serial line protocol is a world-wide de facto standard. Its simplicity, reliability and low cost enabled it to have today, probably the most important installed base of communicating industrial products.

It is still the best technical/cost compromise for products without needs of high end communication performances.

Modbus products connection into Transparent Ready architectures with gateways of Schneider Electric group (see page 88 to 90, 92 and 93), is deliberately easy to manage and provides:

- Large openness capabilities at low cost, to all Modbus compliant devices of the market place
- Connection capabilities to existing applications
- A point of entry into Transparent Ready at an optimized cost
- Same application layer over a serial line than Ethernet TCP/IP, enabling transparent message routing.

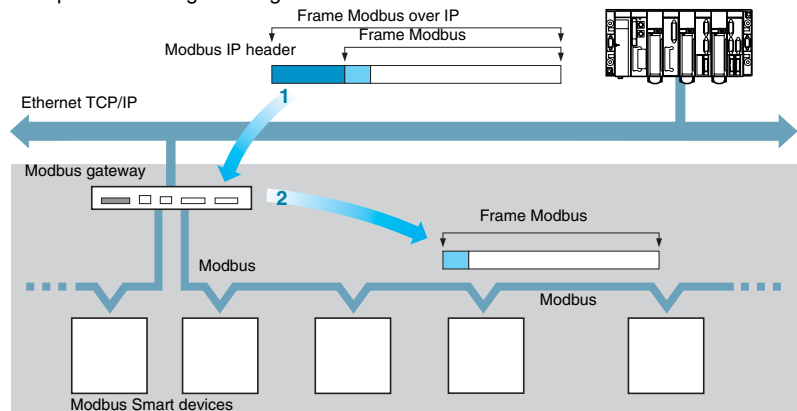

#### Mechanism of transparent data access with Modbus messaging

In case of data access to Modbus devices with Modbus messaging, the gateway as no more added value than the address translation, encapsulated and desencapsulated Modbus frames, whatever Modbus function code used.

This feature is totally transparent for the system, that makes no real difference from an Modbus device connected via a gateway and a device directly connected to Ethernet TCP/IP. The only difference should be performance.

Modbus devices connected via a gateway benefit both of Ethernet bandwidth & multi-master feature.

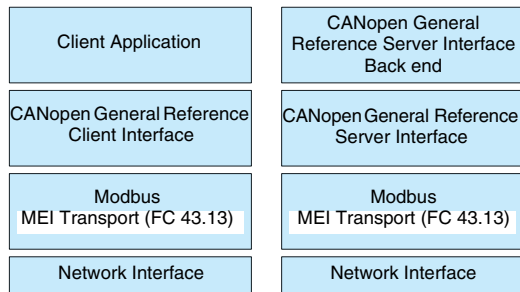

Interfacing CANopen with TCP/IP – Part 2 Modbus TCP/IP Mapping: Device View of Client and Server Modules

### 3 Field level (continued)

#### Communication with field products CANopen

Modbus-IDA and CAN in Automation have commonly made the specification CiA DSP 309-2: Interfacing CANopen with TCP/IP Part 2: Modbus/TCP Mapping. CiA DSP 309-2 provides a standardized mapping of CANopen data for transport on Modbus TCP/IP networks. In the specification, Modbus Function Code 43/13 is reserved for this purpose. The function code exclusively reserved for CANopen.

The specification is available in the CAN in Automation (CiA) Web site for CiA members (<http://www.can-cia.org>) and for Modbus-IDA members (see page 127) upon request ([headquarters@can-cia.org](mailto:headquarters@can-cia.org)).

The specification defines mapping services so that CANopen devices can communicate over a Modbus TCP/IP network via a gateway device or through the incorporation of a local Modbus TCP/IP transport layer. Access to the entries of a CANopen object dictionary is supported on both a read and write basis, along with a variety of device control functions.

This specification is the first standard allowing the implementation of an open communication between Modbus/TCP and CANopen. It will leverage the Schneider Electric network solution towards a better integration, diagnostic and configuration in distributed applications. It enables machines and installation to be seamless connected to an Ethernet plant floor combining the advantages of each network in its specific area.

#### Communication between field PCs or operator terminals, PLCs and field devices

This type of communication is used to configure, monitor and maintain field level devices.

It must be simple so that less qualified personnel can access first level diagnostics from a standard PC. The most suitable Transparent Ready service for this is the display of diagnostic and customized Web pages. See pages 22 to 25.

All the functions of Magelis XBT F/XBT G/XBT GT graphic display terminals are also available on Ethernet TCP/IP.

The SNMP standard network management protocol can also be used from a network management station to monitor, control and perform diagnostics on all the components of the Ethernet architecture.

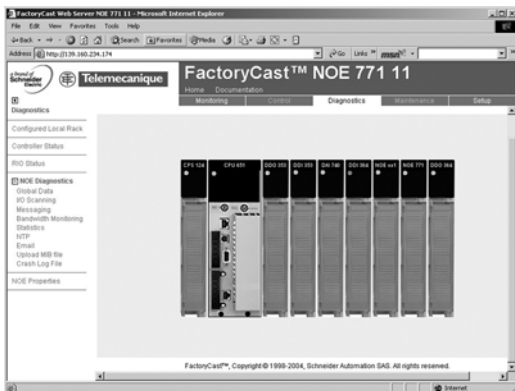

#### Choice of Transparent Ready services

The following table can be used to select the Transparent Ready service according to the required type of communication.

Communication	Company level 1			Inter-PLC level 2		Field level 3		See page
	Communication with MES/ERP	Supervision	Basic HMI application	Inter-PLC communication	Inter-PLC synchronization	Communication with peripherals (I/O)	Diagnostics	
Transparent Ready services								
Modbus TCP/IP								37
Web/FactoryCast servers								24
I/O Scanning								38
Global Data								40
SNMP network management								43
TCP Open								44
OFS server								118
SOAP/XML								32

#### 4 Transparent remote communication

##### Using remote communication

Transparent remote communication is possible, with no need for any special interface, for programming, diagnostics, data exchanges, viewing and adjustment, in a similar way to connecting to a local area network.

This type of connection is used for remote access to automation products via the PLC programming tool, or by viewing Web pages with a simple Internet browser. Transparent remote access can also be used for the other Transparent Ready services.

##### Remote communication on the Internet

Transparent remote communication on the Internet is possible without the need for any special interfaces. For this, an Internet connection must be available. If not, contact a local Internet service provider.

This type of connection is used for remotely accessing automation products at a lower communication cost and over very long distances, using:

- The PLC programming tool
- A simple Internet browser for viewing the Web pages of the automation products that have an embedded Web server.

As use of the Internet involves security risks for the system, this type of access must be made secure by a Firewall. The use of a VPN (Virtual Private Network) is also possible. This type of function must be provided by the Firewall or by an additional device.

For further information on remote management services, see “Partnership Program” page 128.



#### 4 Transparent remote communication (continued)

##### Remote communication via telephone networks

Transparent point-to-point communication on the telephone network is possible using a remote access router or RAS (Remote Access Server). Since TSX ETZ410/510 Ethernet Web server modules for Modicon TSX Micro PLCs incorporate this function themselves, there is no need to use an external server/router.

A modem for wired telephone link or GSM is also necessary for telephone communication.

To access remotely other PLCs, we recommend to use TSX ETG Web gateways (see pages 80 and 89) or W@de Remote Terminal Unit W@de for water applications (see pages 108 and 109).

As with any connection via a telephone network, access must be made secure by identification functions, or filtering by a Firewall, automatic callback by the access server or VPN server.

For further information on remote telephone connections, please consult your Regional Sales Office.

##### Remote communication by radio

Transparent remote communication by radio is also possible on Ethernet TCP/IP, both for communication between products and for links with HMI terminals which can thus be mobile.

Various types of radio technology are compatible with Ethernet TCP/IP:

- Bluetooth
- Wi-Fi
- Special wireless industrial systems, based on the 2.4 Gaze frequency.

Further information on this field, and details of partners supplying these types of technology for use with Transparent Ready products, are given on pages 128 to 147.

#### Other requirements of Ethernet TCP/IP architectures

##### Diagnostic services

Diagnostic services are available from the PLC programming tools, which provide in particular:

- Display of the PLC system status
- Diagnostics of the communication services on Ethernet TCP/IP (Modbus TCP/IP messaging, I/O Scanning and Global Data services)
- Display of the Bandwidth in Ethernet TCP/IP modules (module load level)

Similar or additional services are also available using a simple Internet browser by viewing the PLC Web pages:

- “Ready to use” pages for displaying the PLC status, “Rack Viewer” function
- Communication and Ethernet TCP/IP services diagnostics pages (communication statistics, I/O Scanning service and Global Data service)
- Access to the PLC variables and data via the “Data Editor” function
- “Alarm viewer” function for displaying alarms on Modicon Premium and Quantum PLCs
- User Web pages created with the “Graphic Data Editor” function or created using a standard tool, such as Microsoft FrontPage

In addition to these diagnostics functions there are also the services provided by the standard SNMP protocol (Simple Network Management Protocol). A network management station can also monitor, control and perform diagnostics on all the components of the Ethernet architecture and can in particular access the objects specific to the Transparent Ready offer contained in the private MIB (Management Information Base) of the PLC communication module.

For more information on Network diagnostic tool see the “Collaborative Automation Partner Program” chapter page 127.

##### Interoperability with third-party products or protocols

Some applications require communication on Ethernet TCP/IP with products from other suppliers. If these products do not have the Modbus TCP/IP protocol, it is possible to use one of the following 4 solutions:

- 1 Use TCP Open for managing communication with the third-party product directly on the TCP/IP layer in accordance with a specific protocol.
- 2 Develop the Modbus TCP/IP protocol on the third-party product, if it provides open access to the TCP/IP layer. This development is made easy by the simplicity of the Modbus TCP/IP protocol. The specifications are available on the Internet from Modbus-IDA (see page 128).
- 3 If the third-party product has a Modbus serial link, use the gateway to the Modbus protocol on TCP/IP (see pages 88 to 90).
- 4 If the product is compatible with an OPC server, it is possible to create an interface on Ethernet TCP/IP between this product and Telemecanique brand PLCs via an OPC client/server PC (equipped with Telemecanique OFS data server software).
- 5 If the product has a CANopen connection (e.g. variable speed drives, motor starter, pneumatic valves...), connect it to:
  - an Advantys STB automation island (see page 79),
  - a Premium or Twido PLC. The Modbus function code 43/13 access to the entries of a CANopen object dictionary supported on both a read and write basis, along with a variety of device control functions (see page 70). The I/O scanning service will be also available to exchange data with the STB Advantys Ethernet interface.

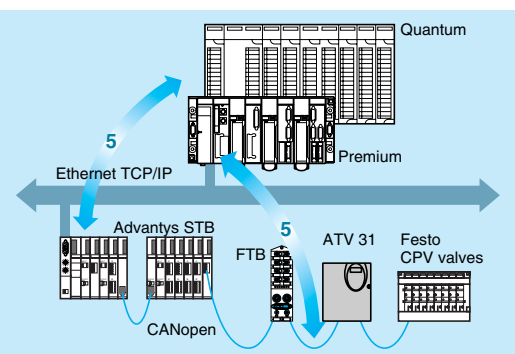
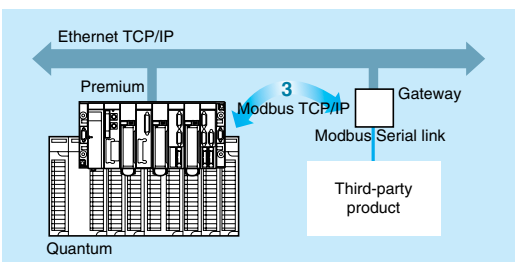
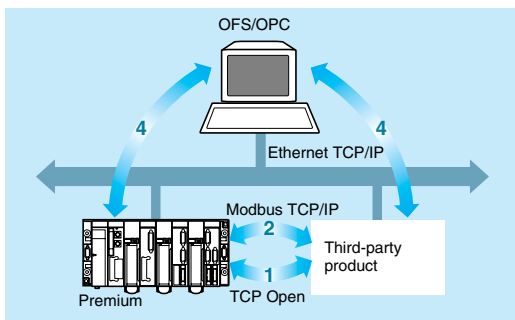

#### Other requirements of Ethernet TCP/IP architectures (continued)

##### Ethernet TCP/IP network security

Security risks on Ethernet TCP/IP are higher than when using proprietary networks, for the following reasons:

- Ethernet TCP/IP is a universal communication network that is familiar and accessible to a huge number of users
- The use of Ethernet TCP/IP for automation products enables external connection without the need for any interfaces.

There are three main risks:

- Multiple "PING" requests with the ICMP protocol to create a denial of service to the module
- Reading/modification of Web server pages with the FTP protocol
- Modification of PLC variables with TCP/IP modems.

Virus risks are extremely limited at control system product level, as they are based on special operating systems.

The risks must be dealt with at each level:

- Company level 1: Possibility of using a router as access manager to the lower levels, by filtering the IP addresses and permitted communication protocols. (Please consult your Regional Sales Office for any additional information)
- Inter-PLC level 2 and field level 3: Set up an internal security policy, ensuring that only authorized people can connect to the network locally. Use the authentication, password and IP address filtering functions available at control system product level
- Transparent remote communication 4 (see page 72).

Use dedicated solutions thanks to partners networking offer (see Collaborative Automation Partner Program, page 127).



**3 - Product data sheets**

- Modicon® Momentum™ distributed I/O ..... page 78
- Advantys™ STB distributed I/O ..... page 79
- Advantys™ OTB distributed I/O ..... page 80
- Lexium® 17D servo drives for brushless motors ..... page 81
- ALTIVAR™ 71 variable speed drives ..... page 82
- ALTIVAR™ 61 variable speed drives dedicated to  
pump and fan applications..... page 83
- Inductel™ identification system ..... page 84
- Ositrack™ identification system ..... page 85

#### Presentation



Momentum I/O bases equipped with 170 ENT 110 0 Ethernet communication adapters create a distributed I/O system on an Ethernet TCP/IP network.

Each I/O base and communicator assembly constitutes a device on the network. Types of base available:

- Discrete: inputs or outputs (32 channels max.), mixed I/O (20 or 32 channels max.).
  - Analog: current or voltage inputs or outputs, Pt/Ni thermocouple, temperature probe or mV inputs.
  - Mixed, up to 16 discrete I/O and 10 analog I/O.
  - Application-specific: 200 kHz 2-channel counter, Modbus port with 9 discrete I/O
- Sensors and preactuators are connected on removable screw or spring terminals.

#### Description

Ethernet TCP/IP 170 ENT 110 02/01 communication adapters comprise:

- 1 Standard connector for 10BASE-T or 10BASE-T/100BASE-TX interface depending on model (RJ45).
- 2 Area for identification label (supplied with each I/O base).
- 3 LED status indicators.

All the communication adapters can be fitted on any type of I/O base (discrete, analog or application-specific).

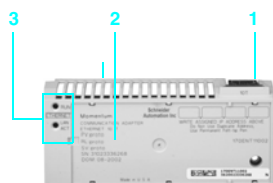

#### Characteristics

Type of communicator		170 ENT 110 02	170 ENT 110 01	
Transparent Ready services	Class	A10	B20	
	Standard Web server	–	“Rack Viewer” access to the product description and status and to base unit diagnostics “Data editor” access to the configuration functions and variables	
Standard Ethernet TCP/IP communication services		Modbus Messaging (read/write data words)		
		–	FDR client for automatic assignment of the IP address and network parameters SNMP agent, detection of the product by an SNMP manager	
Structure	Physical interface	RJ45 standard 10BASE-T connector	RJ45 standard 10BASE-T/100BASE-TX connector	
	Data rate	10 Mbps	10/100 Mbps with automatic recognition	
	Medium	Twisted pair		
Ethernet communication adapter	Operating temperature	0...+ 60°C		
	Relative humidity	5...95% non condensing		
	Degree of protection	IP 20		
	Power supply	Via I/O base		
	I/O bases	Discrete inputs	= 24 V (16 or 32 channels), ~ 120 V and 230 V (16 channels)	
		Discrete solid state outputs	= 24 V/0.5 A (16 or 32 channels), ~ 120 and 230 V/0.5 or 2A (8 or 16 channels)	
		Discrete solid state mixed I/O	Inputs = 24 V (16 channels) and Outputs = 24 V/0.5 or 2 A (8, 12 or 16 channels) Inputs ~ 120 V (10 channels) and Outputs ~ 120 V/0.5 A (8 channels)	
		Relay mixed I/O	Inputs = 24 V (10 channels) and Relay outputs = 20...115 V or Outputs ~ 24...230 V/2 A (8 N/O channels)	
		Analog inputs	Voltage/current (8 or 16 channels), thermocouple/temperature probe (4 channels)	
	Analog outputs	- 10 V...+ 10 V, 0...20 mA or - 10 V...+ 10 V, 4...20 mA (4 channels)		
Mixed discrete and analog I/O	4I/2Q analog voltage/current and 4I/2Q = 24V 6I/4Q analog 0...10 V and 8I/8Q = 24 V, 6I/4Q analog. - 10...+ 10 V and 8I/8Q = 24 V			
Application-specific	200 kHz 2 channel counter, module 6I/3Q ~ 120 V with 1 RS 485 Modbus port			
Conformity to standards	UL, CSA, CE, FM Class 1 Division 2		UL, CSA, CE	
LED indicators	Ethernet network status (LAN Active) Module status (RUN)		Ethernet network status (ST), data rate (10T, 100T) Module status (RUN)	

#### References

Description	Transparent Ready Data rate class	Data rate	Reference	Weight kg
Ethernet communication adapters	A10	10 Mbps	170 ENT 110 02	0.070
	B20	10/100 Mbps	170 ENT 110 01	0.070

(1) I/O bases and separate parts: Please consult our “Modicon Momentum automation platform” catalog.



170 ENT 110 02/01

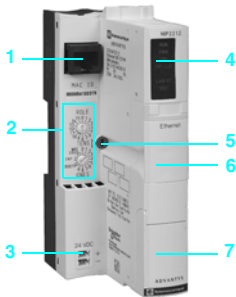

### Presentation

The Advantys STB distributed I/O solution is an open, modular I/O system. It can be used to design industrial automation islands managed by a master controller connected to various buses and networks, including Ethernet TCP/IP. Each island comprises a set of modules mounted on a DIN rail to make up one or more segments in which the power supplies (logic = 5 V, sensors and preactuators = 24 V or ~ 115/230 V) are distributed automatically. The Advantys STB I/O family can be divided into 2 groups of modules:

- Standard range: comprehensive offer with configurable parameters.
- Basic range: just enough offer but (without parametrizing) with fewer functions and non-configurable modules.

Sensors and preactuators are connected on removable screw or spring terminals. The Advantys configuration software is used to set the parameters of the numerous I/O module functions (logic of each channel, behavior in the event of a short-circuit or overload, fallback position, reflex functions, etc)

### Description

The STB NIP 2212 Ethernet TCP/IP network interface module has the following on the front panel:

- 1 A standard connector for 10BASE-T interface (RJ45).
- 2 Two rotary selector switches for addressing nodes on the bus or the network.
- 3 A = 24 V external power supply connector for the removable screw-type (STB XTS 1120) or spring-type (STB XTS 2120) terminals.
- 4 An LED display block.
- 5 A screw for unlocking the module from the DIN rail.
- 6 A slot for an STB XMP 4440 removable memory card.
- 7 Cover for access to: a port for connecting the island setup and configuration PC or an HMI terminal (read/write data), and the Reset button.

On the right-hand side panel:

A bus connector for connecting (via base units) to the power distribution module and to the I/O modules (max. 32 modules on 7 segments).

### Characteristics

<b>Transparent Ready services</b>	Class	B20	
	Standard Web server	"Rack Viewer" access to the product description and status and to the island diagnostics "Data editor" access to the configuration functions and variables	
	Ethernet TCP/IP communication management service	Modbus messaging (read/write data words) FDR client for automatic assignment of the IP address and network parameters SNMP agent, detection of the product by an SNMP manager	
<b>Structure</b>	Physical interface	RJ45 standard 10BASE-T connector	
	Data rate	10 Mbps	
	Medium	Twisted pair	
<b>Ethernet communication adapter</b>	Operating temperature	0...+ 60°C without derating	
	Relative humidity	95% non condensing at 60°C	
	Degree of protection	IP 20	
	Power supply	= 24 V (limits = 19.2...30 V), 750 mA maxi	
	Max. number of I/O modules	32 per island	
	Number of segments	1 primary and 6 extensions (on 15 m maxi)	
	I/O modules (standard and basic)	Discrete inputs	= 24 V (2, 4, 6 or 16 channels), ~ 115 V and 230 V (2 channels)
		Discrete solid state outputs	= 24 V/0.5 A (2, 4, 6 or 16 channels), = 24 V/2 A (2 channels), ~ 115...230 V/2 A (2 channels)
		Relay outputs	= 24 V or ~ 115...230 V 2 "C/O"/2 A, 2 "N/C" + "N/O"/7A
		Analog inputs	- 10 V...+ 10 V, 0...20 mA, multi-range (2 channels)
	Analog outputs	- 10 V...+ 10 V, 0...20 mA (2 channels)	
	Application-specific	Tego Power 8 motor starters (16 inputs), TeSys model U 4 controller-starters (12 inputs) 40 kHz 1 channel counter	
	Conformity to standards	IEC/EN 61131-2, UL 508, CSA 1010-1, FM Class 1 Division 2, Cc Marine classification: ABS, BV, DNV, GL, LR and RINA	
	LED indicators	Ethernet network status (10T ACT, LAN ST) Module and island status (POWER, RUN, ERROR and TEST)	



STB NIP 2212

### References

Description	Use	Reference	Weight kg
<b>Ethernet "NIM" network interface modules</b> Class B20	= 24 V power supply	<b>STB NIP 2212</b>	0.130
<b>Removable power supply terminals (pack of 10)</b>	Screw	<b>STB XTS 1120</b>	0.003
	Spring	<b>STB XTS 2120</b>	0.003
<b>32 Kb removable memory card</b>	Application memory backup	<b>STX XMP 4440</b>	-

(1) Power distribution modules, I/O modules, bases, configuration software and separate parts: Please consult our "Advantys STB I/O, the open solution" catalog.

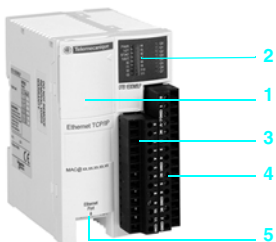

### Presentation

The Advantys OTB distributed I/O solution, which complements the Advantys STB offer, consists of a compact system (network interface and integrated I/O) with the addition of Twido I/O expansion modules. Each island has, on a DIN rail:

- A network interface module (including Ethernet TCP/IP) with 12  $\sim$  24 V inputs, 6 relay outputs and 2 solid state outputs  $\sim$  24 V 0.3 A.
- As an extension, up to 7 discrete or analog I/O expansion modules.

This structure, created using IP 20 modules, can thus be used to manage 20 to 244 I/O per island over a maximum length of 328.7 mm (height 94.5 mm).

### Description

The OTB 1E0 DM9LP Ethernet TCP/IP network interface module with integrated I/O has the following on the front panel:

- 1 A pivoting door for accessing a standard to rotary switches for Ethernet address assignment (IP by default, by DHCP server or by BOTTP server).
- 2 An LED display block.
- 3 Screw terminals for the  $\sim$  24 V sensor power supply and for connecting the input sensors (with 1 common).
- 4 Screw terminals for connecting the output preactuators (with 4 commons).
- 5 A standard connector for 10BASE-T/100BASE-TX physical interface (RJ45).

On the right-hand side panel:

A connector for TWD D●●/A●● I/O expansion modules (7 modules max.).

### Characteristics

<b>Transparent Ready services</b>	Class	A10
	Standard Web server	None
	Standard Ethernet TCP/IP communication service	Modbus messaging (read/write data words)
<b>Structure</b>	Physical interface	RJ45 standard 10BASE-T/100BASE-TX connector
	Data rate	10/100 Mbps with automatic recognition
	Medium	Twisted pair
<b>Ethernet communication adapter</b>	Operating temperature	0...+ 55°C
	Relative humidity	30...95% non condensing
	Degree of protection	IP 20
	Power supply	$\sim$ 24 V (limits $\sim$ 20.4...26.4 V)
	Inputs	12 inputs $\sim$ 24 V, 5 and 7.7 mA, 1 common point (positive or negative logic) Connection via removable screw terminals
	Outputs	6 $\sim$ 230 V or $\sim$ 30 V, 2 A relay outputs, 3 common points (1 x 3, 1 x 2 and 1 x 1) 2 $\sim$ 24 V, 0.3 A transistor outputs, 1 common point (positive logic) Connection via removable screw terminals
	Conformity to standards	IEC 61131-2, UL 508 CSA C22.2 No. 213 (Class 1 Division 2 Groups A, B, C, D), c c
	LED indicators	Controller status (PWR and STAT), I/O (I●/Q●) Ethernet network status/10 or 100 Mbps data rate (10 T and 100T)

### References



Description	No. of discrete I/O	Reference	Weight kg
<b>Ethernet network interface module</b> $\sim$ 24 V power supply	12 $\sim$ 24 V inputs 6 relay outputs 2 $\sim$ 24 V solid state outputs	<b>OTB 1E0 DM9LP</b>	0.205
Class A10			

### Discrete I/O expansion modules

Number of channels	8	16	4 I/4 Q	16 I/8 Q
$\sim$ 120 V inputs	TWD DAI 8DT	–	–	–
$\sim$ 24 V inputs	TWD DDI 8DT	TWD DDI 16DT	TWD DMM 8DRT	TWD DMM 24DRF
2 A relay outputs	TWD DRA 8RT	TWD DRA 16RT	–	–
$\sim$ 24 V 0.3 A transistor outputs	TWD DDO 8TT	–	–	–

### Analog I/O expansion module

Number of channels	1	2	4	8	2 I/1Q
0...10 V, 0...20 mA inputs	–	–	TWD AMI 4LT	TWD AMI 8HT	–
Thermocouple/Pt temp. probe inputs	–	–	–	TWD ARI 8HT	TWD ALM 3LT
0...10 V, 4...20 mA outputs	TWD AMO 1HT	–	–	–	TWD AMM 3HT
0...10 V, 4...20 mA inputs	–	TWD AMI 2HT	–	–	–
+/- 0...10 V outputs	–	TWD AVO 2HT	–	–	–

For further information, please consult our "Automation and control, automation and relay functions" catalog.



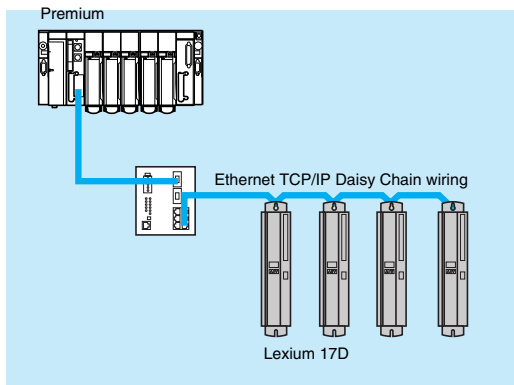

#### Presentation.

Lexium 17D digital drives provide static switching, current (or torque) regulation, speed regulation and position control for BPH, BPL or SER brushless motors. They are available in 7 current ratings (1.5, 3, 6, 10, 20, 40 and 70 A rms continuous).

In offline mode with integrated position indexer (simple applications that do not require a PLC position control module), Lexium 17D drives have a slot that can take an Ethernet TCP/IP network card. As well as the standard Ethernet connections via switches or hubs (for example, from the ConneXium range), this Ethernet card which has 2 Ethernet ports enables daisy chain connection of up to 32 Lexium 17D drives. Switches or hubs can be used to create a topology with a number of daisy chains.

The Unilink software is used for local configuration of the Ethernet parameters and Ethernet, Modbus and drive diagnostics. Modbus messaging is used to access all this information on Ethernet.

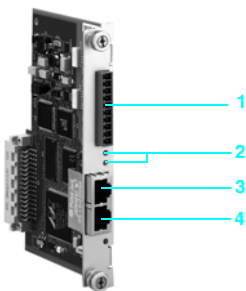

#### Description

Lexium 17D drives are connected to the Ethernet TCP/IP network via the **AM0 ETH 001V000** or **AM0 ETH 002V000** communication card. The cards have the following on the front panel:

- 1 A 10-way Phoenix removable connector for connecting 8 configurable discrete inputs (with AM0 ETH 002V000 card).
- 2 LED indicators.
- 3 A standard connector for 10BASE-T/100BASE-TX interface (RJ45).
- 4 A standard connector for 10BASE-T/100BASE-TX interface (RJ45) for daisy chain connection.

#### Characteristics

<b>Transparent Ready services</b>	Class	A10
	Standard Web server	No Web server
<b>Structure</b>	Standard Ethernet TCP/IP communication services	Modbus messaging (read/write drive parameters (240 bytes max), identification and diagnostics Save and restore drive parameters and "Motion Tasks" in blocks via dedicated registers FDR client for local assignment of the IP address I/O Scanning service (22 control words and 19 status words)
	Physical interface	2 x RJ45 standard 10BASE-T/100BASE-TX connectors (ETH1, ETH2) for daisy chain connection
<b>Lexium 17D drives</b>	Data rate	10/100 Mbps with automatic recognition
	Medium	Twisted pair
<b>Lexium 17D drives</b>	Operating temperature	0...+ 45°C, + 45...+ 55°C with derating, see our "Lexium 17D motion control" catalog
	Relative humidity	85% non condensing
	Degree of protection	IP 21
	Power supply	208...480 V~ 3-phase
	Brushless motor output	Continuous/ <i>maximum</i> current: 1.5 A/3 A to 70 A/140 A depending on the model
	Conformity to standards	EN 50178, EN 60139-1, EN 60204, UL 508C, UL 840, CSA 22-2 Machine safety NF EN 292-1, EN954-1
	LED indicators	Transmission/reception activity (ACT for ETH1, ACT for ETH2), communication status (STS)

#### References



Description	For Lexium drive	Number of discrete inputs	Reference	Weight kg
<b>Communication cards</b> Ethernet Modbus TCP/IP 10/100 Mbps	MHDA	–	<b>AM0 ETH 001 V000 ▲</b>	0.180
	1●●N00/A00	8	<b>AM0 ETH 002 V000 ▲</b>	0.195

Class A10

▲ Available later



ATV 71 without graphic terminal



ATV 71 with graphic terminal

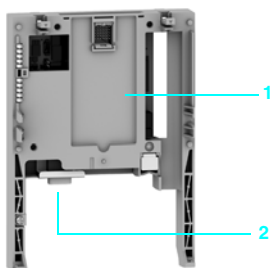

### Presentation

The Altivar 71 range of variable speed drives extends across a range of motor power ratings from 0.37 kW to 500 kW with three types of power supply:

- 200\_240 V single-phase, from 0.37 kW to 5.5 kW
- 200\_240 V 3-phase, from 0.37 kW to 75 kW
- 380\_480 V 3-phase, from 0.75 kW to 500 kW.

Open to all industrial communication networks and featuring numerous automation system options, the Altivar 71 adapts effortlessly to complex sophisticated machines. Its performance levels and ease of parameter setting make it the reference product up to 500 kW. It can be connected to Ethernet Transparent Ready by an optional card.

The Altivar 71 can be inserted in an installation's safety system. It integrates the "Power Removal" safety function which prohibits any accidental starting of the motor. This function complies with machine standard EN 954-1 category 3, the standard governing electrical installations IEC/EN 61508 SIL2 and the power drive systems standard IEC/EN 61800-5-2.

The functionality of the Altivar 71 drive boosts performance and increases a machine's flexibility of use across multiple applications (handling, hoisting, process machines, textile machines, packaging, ...).

### Description

The Altivar 71 variable speed drive can integrate a maximum of three option cards simultaneously, of which the Ethernet TCP/IP communication card. All the drive functions can be accessed via Modbus services: controlling, monitoring, adjustment and configuration.

- 1 An optional Ethernet TCP/IP communication card.
- 2 A standard connector for 10BASE-T/100BASE-TX interface (RJ45).

### Characteristics

<b>Transparent Ready services</b>	Class	C20
	Standard Web services (1)	"Altivar Viewer" drive diagnostics "Data editor" access to the configuration, adjustment and signaling functions "Altivar chart" simplified oscilloscope function "Security" configuration of passwords to access viewing and modification "Ethernet statistics" drive identification and transmission statistics
	Configurable Web service	Downloading user defined Web pages via FTP
	Standard Ethernet TCP/IP communication services	Modbus TCP/IP messaging (read/write registers, read device identification, diagnostics) BOOTP, DHCP (8 simultaneous Modbus TCP/IP connections), TFTP
<b>Ethernet structure</b>	Ethernet TCP/IP advanced communication services	I/O Scanning, 10 control variables and 10 monitoring variables freely configurable (2) FDR client, automatic assignment of the IP address and network parameters SNMP agent, detection of the product by an SNMP manager
	Physical interface	RJ45 standard 10BASE-T/100BASE-TX connector
	Data rate	10/100 Mbps with automatic recognition
<b>Variable speed drive</b>	Medium	Twisted pair
	Operating temperature	- 10...+ 50°C or - 10...+ 60°C with derating and with the control card fan kit VW3 A9 4●●
	Relative humidity	5...95 % without condensation or dripping water conforming to IEC 60068-2-3
	Degree of protection	IP 21 or IP00 (depending on model) and IP 41 on upper part (with cover plate)
	Output frequency range	1...1000 Hz or 1...500 Hz depending on model
	Speed range	1...100 in open loop mode
	Motor control profile with motor	Asynchronous: Flux vector control with or without sensor, voltage/frequency ration (2 or 5 pulses), ENA system Synchronous: Vector control without speed feedback
	Conformity to standards	IEC/EN 61800-5-1, IEC/EN 61800-3 (environments 1 and 2 categories C1 to C3, C€, UL, CSA, DNV, C-Tick, NOM 117 and GOST
LED indicators	5 LEDs on the card: RX (reception), TX (transmission), FLT (collision detection), STS (IP address) and 10/100 Mbps (speed)	

### Reference



VW3 A3 310

Description	For drive	Reference	Weight kg
<b>Communication card</b> Ethernet Modbus TCP/IP 10/100 Mbps	ATV 71, ATV 61	<b>VW3 A3 310</b>	0.300
Class C20			

(1) The standard Web server can be adapted or replaced by a customized Web server depending on the requirements of the application. Knowledge of HTTP protocol and Java technology is required to make modifications.

(2) The periodic variables of I/O Scanning may be freely assigned according to the needs of the application.



ATV 61 without graphic terminal



ATV 61 with graphic terminal

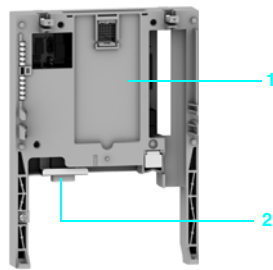

### Presentation

Dedicated to pump and fan applications in building and industrial segments, the Altivar 61 variable speed drives adapt effortlessly to simple catalog machines. Its performance levels and ease of parameter setting make it the reference product. Open to all building and industrial communication networks, it can be connected to Ethernet Transparent Ready by an optional card.

The Altivar 61 range of variable speed drives extends across a range of motor power ratings up to 630 kW with two types of power supply:

- 200\_240 V 3-phase, up to 90 kW
- 380\_480 V 3-phase, up to 630 kW.

The Altivar 61 integrates the numerous functions: PID regulator, automatic motor adaptation, automatic restart, sleep and wake up mode, flying mode, ...

The Altivar 61 can be inserted in an installation's safety system. It integrates the "Power Removal" safety function which prohibits any accidental starting of the motor. This function complies with machine standard EN 954-1 category 3, the standard governing electrical installations IEC/EN 61508 SIL2 and the power drive systems standard IEC/EN 61800-5-2.

### Description

The Altivar 61 variable speed drive can integrate a maximum of three option cards simultaneously, of which the Ethernet TCP/IP communication card. All the drive functions can be accessed via Modbus services: controlling, monitoring, adjustment and configuration.

- 1 An optional Ethernet TCP/IP communication card.
- 2 A standard connector for 10BASE-T/100BASE-TX interface (RJ45).

### Characteristics

<b>Transparent Ready services</b>	Class	C20
	Standard Web services (1)	"Altivar Viewer" drive diagnostics "Data editor" access to the configuration, adjustment and signaling functions "Altivar chart" simplified oscilloscope function "Security" configuration of passwords to access viewing and modification "Ethernet statistics" drive identification and transmission statistics
	Configurable Web service	Downloading user defined Web pages by FTP
	Standard Ethernet TCP/IP communication services	Modbus TCP/IP messaging (read/write registers, read device identification, diagnostics) BOOTP, DHCP (8 simultaneous Modbus TCP/IP connections), TFTP
<b>Structure</b>	Ethernet TCP/IP advanced communication services	I/O Scanning, 10 control variables and 10 monitoring variables freely configurable (2) FDR client, automatic assignment of the IP address and network parameters SNMP agent, detection of the product by an SNMP manager
	Physical interface	RJ45 standard 10BASE-T/100BASE-TX connector
<b>Drive</b>	Data rate	10/100 Mbps with automatic recognition
	Medium	Twisted pair
	Operating temperature	- 10...+ 50°C or - 10...+ 60°C with derating and with the control card fan kit VW3 A9 4●●
	Relative humidity	5...95 % without condensation or dripping water conforming to IEC 60068-2-3
	Degree of protection	IP 21 or IP00 (depending on model) and IP 41 on upper part (with cover plate)
	Output frequency range	1...1000 Hz or 1...500 Hz depending on model
	Speed range	1...100 in open loop mode
	Motor control profile with asynch. motor	Flux vector control without sensor, voltage/frequency ration (2 or 5 pulses), ENA system
<b>LED indicators</b>	Conformity to standards	IEC/EN 61800-5-1, IEC/EN 61800-3 (environments 1 and 2 categories C1 to C3, C€, UL, CSA, DNV, C-Tick, NOM 117 and GOST
		5 LEDs on the card: RX (reception), TX (transmission), FLT (collision detection), STS (IP address) and 10/100 Mbps (speed)

### Reference



VW3 A3 310

Description	For drive	Reference	Weight kg
<b>Communication card</b> Ethernet Modbus TCP/IP 10/100 Mbps	ATV 71, ATV 61	<b>VW3 A3 310</b>	0.300
Class C20			

(1) The standard Web server can be adapted or replaced by a customized Web server depending on the requirements of the application. Knowledge of HTTP protocol and Java technology is required to make modifications.

(2) The periodic variables of I/O Scanning may be freely assigned according to the needs of the application.

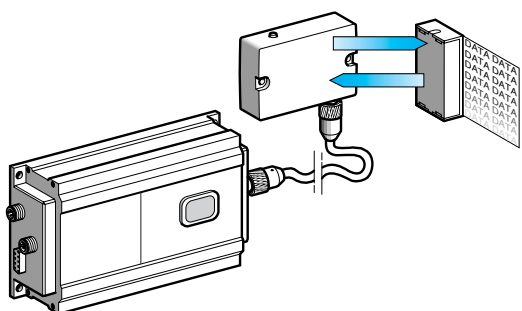

Read/write station with antenna and updatable code badge

## Presentation

Inductive technology is based on the use of a medium frequency electromagnetic signal (carrier), for contactless transmission between two electronic devices. It is used for identifying products during manufacture and improving the management of product-related data flows.

The system consists of:

- Updatable code badges, with decentralized memory (ferroelectric memory or EEPROM), accessible in read and write mode for use with the product to be identified.
- The read/write station with remote antenna, a bidirectional communication device that manages the data transmitted between the badge and the processor via the Ethernet TCP/IP network.

## Description

The **XGKS 1715503** read/write station is in the form of a dust and damp proof metal box comprising:

- 1 A 5-way female M12 connector for connection to the antenna (XGLA... or XGPA...).
- 2 A display block consisting of 5 LEDs indicating the station status.
- 3 A removable cover for accessing the station configuration switches.
- 4 A 20UNF 3 1/2" 3-pin male connector for connecting the --- 24 V station power supply (female connector to be ordered separately).
- 5 An IP 65 shielded base for connection to the Ethernet network.

The special connector supplied with the station is used to form a dust and damp proof connection using any standard RJ45 cable.

This station (210 x 60 x 235), is fixed onto a frame or panel using 4 screws (4 x 8 holes).

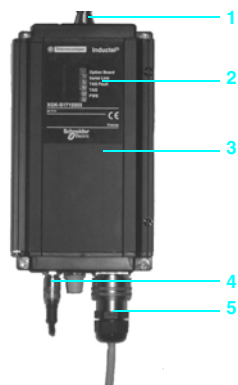

## Characteristics

<b>Transparent Ready services</b>	Class	B10	
	Standard Web server	"Inductel Viewer" access to the product description, status and diagnostics "Data editor" access to the configuration functions and variables	
	Standard Ethernet TCP/IP communication service	Modbus messaging (read/write I/O words)	
<b>Structure</b>	Physical interface	10BASE-T/100BASE-TX, standard RJ45 connector with IP 65 shielded base	
	Data rate	10/100 Mbps with automatic recognition	
	Medium	Double twisted pair	
<b>Network interface module controller</b>	Operating temperature	0...+ 50°C	
	Relative humidity	30...95% non condensing	
	Degree of protection	IP 65	
	Power supply	--- 24 V (limits --- 21...29 V)	
	External antenna	5-way female M12 connector (antenna/station link 2 m max.)	
	Communication	Requests	Modbus TCP/IP 124 words max.
		Data rate	500 words/s max. depending on antenna used
	Conformity to standards	UL, CE	
LED indicators	Electromagnetic interference, level 3 according to IEC 61000-4-2/4-3/4-3 On (green), badge present (yellow), badge and communication port faults (red) Ethernet network activity (RUN, green), collision detection (COL, red), diagnostics (STS, yellow) and fault (ERR, red)		

## References



XGK S1715503

Description	Integrated Ethernet port	Reference	Weight kg
<b>Read/write station</b> --- 24 V power supply	10/100 Mbps	<b>XGK S1715503</b>	1.120
Class B10			

Antennae, updatable code badges, connection accessories: please consult our "Inductive identification system" catalog.

## Presentation

This unit is used to connect up to 3 XGC S RFID compact stations to an Ethernet TCP/IP network.

Data is exchanged with the Ositrack stations using the Modbus TCP/IP protocol.

As a server on the Ethernet network, the cable connector can receive and respond to messages.

This data exchange enables the Ethernet TCP/IP network to access certain Ositrack station functions, such as:

- Reading/writing tags
- Control and command
- Monitoring
- Diagnostics.

## Description

The **XGS Z33ETH** cable connector is a dust and damp proof metal box comprising:

- 1 Signaling LEDs relating to the Ethernet TCP/IP network.
- 2 An M12 D-coded connector for connection to the Ethernet TCP/IP network.
- 3 An M12 A-coded connector, for connecting the 24 V  $\equiv$  power supply.
- 4 3 x M12 A-coded connectors for connecting Ositrack XGC S compact stations.

This cable connector, dimensions 237 x 120 x 60 mm, is attached via the rear using 2 screws (4 mm).

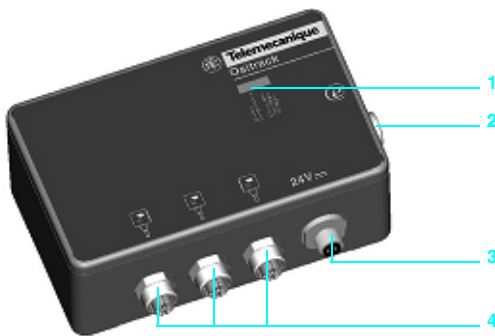

## Characteristics

<b>Transparent Ready services</b>	Class	A10	
	Standard Web server	No Web server	
	Standard Ethernet TCP/IP communication service	Modbus messaging (read/write I/O words)	
<b>Structure</b>	Physical interface	10BASE-T/100BASE-T X	
	Data rate	10/100 Mbps with automatic recognition	
	Medium	Ethernet cable with M12 connection (TCS EN1M3●●)	
<b>XGS cable connector</b>	Operating temperature	- 25...+ 55°C	
	Relative humidity	30...95% non condensing	
	Degree of protection	IP 65	
	Power supply	$\equiv$ 24 V (limits $\equiv$ 21...29 V)	
	Connecting XGC S stations	5-way female M12 connector	
	Communication	Requests	Modbus TCP/IP 124 words max.
		Speed	2 Kbytes/s max. depending on associated tags
	Conformity to standards	UL, CE	
	LED indicators	Electromagnetic interference, level 3 according to IEC 61000 and EN 55022	
		Ethernet network activity (RUN, green), collision detection (COL, red), diagnostics (STS, yellow), fault (ERR, red) and 24 V $\equiv$ power supply (yellow)	

## Reference



XGK Z33ETH

Description	Integrated Ethernet port	Reference	Weight kg
<b>Ethernet cable connector</b> (for 3 XGC S compact stations) 24 V $\equiv$ power supply	10/100 Mbps	<b>XGK Z33ETH ▲</b>	0.830

Class A10

Stations, updatable code badges, connection accessories: please consult our "Inductive identification system" catalog.

▲ Available later



---

## 4 - Product data sheets

- TSX ETG 100 monoport Ethernet/Modbus™ gateway . . . . . page 88
- TSX ETG 1000/1010 Web FactoryCast™ Gateways . . . . . page 89
- 174 CEV 300 20/ CEV 200 40 Ethernet/Modbus™ Plus gateway/router . page 90

# Transparent Ready® Products

## Ethernet gateways

### Ethernet/Modbus gateway

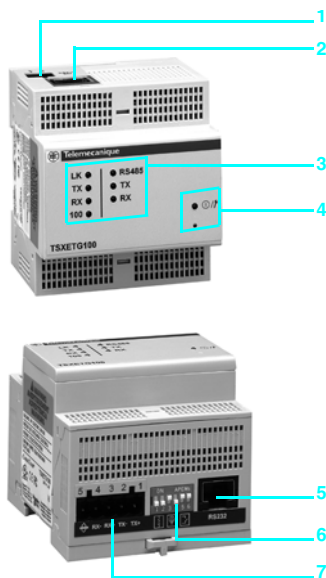

#### Presentation

**TSX ETG 100** gateway provides a simple and low-cost means of integrating any existing Modbus serial RTU device, installation or automation island in an Ethernet TCP/IP network infrastructure.

The gateway is able to make the serial Modbus devices directly accessible to high level application in real time (management, SCADA).

Modbus serial devices can be Twido controller, Compact/Momentum/Premium/Quantum PLCs, Altivar variable speed drives, Altistart starters, Magelis terminals or any other products compatible with the Modbus standards.

#### Description

**TSX ETG 100** gateway is an IP 30 box, mounted on DIN rail.

- 1 A screw terminal for connecting the  $\pm$  24 V power supply.
- 2 A standard RJ45 connector for 10BASE-T/100BASE-TX interface.
- 3 Seven LED indicators for Ethernet communication (LK, RX, TX, 100), and serial link communication (RS485, RX, TX).
- 4 A LED indicator for  $\pm$  24 V power supply and Reset button.
- 5 A RJ45 connector for Modbus RS 232 serial link.
- 6 A micro switches for 2 or 4-wire RS 485 serial link configuration.
- 7 A 5-way removable terminal block for Modbus RS 485 serial link.

#### Characteristics

Type of gateway		<b>TSX ETG 100</b>	
<b>Transparent Ready services</b>	Class	B10	
	Standard Web services	Configuration	Predefined Web pages
		Read/Write	Access to connected products list, reading of Modbus devices registers
		Diagnostic	Via predefined Web pages: diagnostic on Ethernet and Modbus links
	Ethernet TCP/IP communication management services	Modbus messaging	Read/Write Modbus registers of connected devices
SNMP		SNMP Agent, device administration with a SNMP manager	
BOOTP protocol		FDR Client (replacement of defective product)	
Security		Miniature firewall on-board (IP address filtering) and password protection	
<b>Ethernet connectivity</b>	Physical interface	10BASE-T/100BASE-TX (RJ45)	
	Data rate	10/100 Mbps with automatic recognition	
	Medium	Twisted pair	
<b>Modbus connectivity</b>	Type of port	RS 485 (2 or 4-wire) or RS 232	
	Protocol	Modbus (RTU and ASCII)	
	Maxi transmission speed	38,4 Kbps (RS 485), 57,6 Kbps (RS 232)	
	Number of devices	32 max.	
<b>Other characteristics</b>	Operating temperature	0...+ 60 °C	
	Relative humidity	5...95% non condensing at 40 °C	
	Degree of protection	IP 30	
	Dimensions (L x H x P)	72 x 81 x 76 mm, mounting on symmetrical DIN rail	
	Power supply	$\pm$ 24 V, 4 W or by power supply device PoE ( <i>Power Over Ethernet</i> - IEEE 802.3af)	
	Conformity to standards	UL, cUL (conforming to CSA C22-2 no. 14-M91), UL508, C€	
	Environmental resistance	EN 61000-6-2, EN 61000-4-2/3/4/5/6/8, EN 55022/FCC class A	

#### References

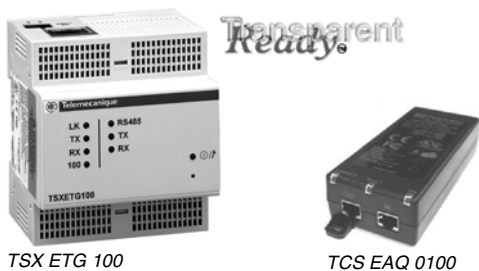

TSX ETG 100

TCS EAQ 0100

Description	Functions	References	Weight kg
<b>Modbus Ethernet gateway/router</b>	Twido, Compact, Momentum, TSX Micro, <b>TSX ETG 100</b> ▲ Altivar, Altistart, Magelis, ... All products compatible with Modbus standard		–
Class B 10			
<b>Kit for configuration</b>	Allows gateway configuration through Ethernet or RS 232 port. Comprises RJ45/9-way SUB-D adaptor and a CAT5 twisted pair cable, 3 m length	<b>TCS EAK 0100</b> ▲	–
<b>PoE power supply (conform to IEEE 802.3af)</b>	Allows gateway power supply through Ethernet CAT5 cable. Daisy chain power supply connection. Include power supply cable (Australia, Europe, UK and USA)	<b>TCS EAQ 0100</b> ▲	–

▲ Available later



# Transparent Ready® Products

## Ethernet gateways

### Web FactoryCast Gateway

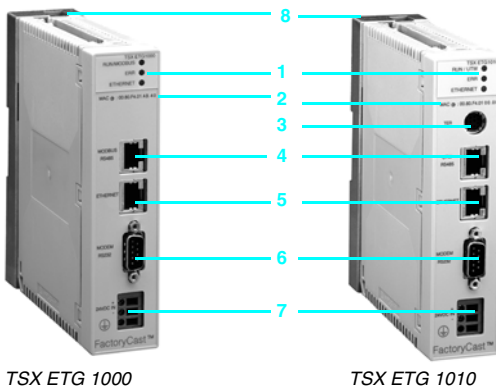

TSX ETG 1000

TSX ETG 1010

### Presentation

FactoryCast Gateway is a new offer of “all in one” intelligent Web gateways integrating, in a standalone compact unit:

- All the TCP/IP network communication and serial link (Modbus or Uni-Telway) interfaces.
- An RAS remote access (1)/IP Router function.
- A customizable Web server.

**TSX ETG 1000/1010** gateways are a low-cost response to the need to integrate serial link installations in an existing Ethernet TCP/IP infrastructure as well as requirements for remote access services including remote diagnostics, remote maintenance, remote monitoring and remote control.

### Description

**TSX ETG 1000/1010** FactoryCast Gateways feature, on the front panel:

- 1 Three LEDs indicating the gateway status (RUN, ERR, Ethernet)
- 2 The module MAC address (default factory-set address)
- 3 A mini-DIN connector for connection to the terminal port (marked TER)
- 4 An RJ45 connector for the serial link (Modbus or Uni-Telway) (marked RS 485)
- 5 A standard RJ45 connector for connection to the Ethernet TCP/IP network (marked ETHERNET)
- 6 A 9-way male SUB-D connector for the RS 232 serial link (marked Modem RS 232)
- 7 A screw terminal for connecting the 24 V<sub>DC</sub> external power supply
- 8 A support plate for fixing the module to a DIN rail or an AM1-PA pre-slotted plate

### Characteristics

Web gateway module	FactoryCast Gateway	TSX ETG 1000	TSX ETG 1010	
<b>Transparent Ready services</b> Class C20	Gateway/router function	Ethernet TCP/IP gateway to Modbus, modem to Modbus and modem to Ethernet TCP/IP with IP routing	Ethernet TCP/IP gateway to Uni-Telway, modem to Uni-Telway and modem to Ethernet TCP/IP with IP routing	
	Protocols	Serial TCP/IP	Modbus master Modbus TCP/IP	Uni-Telway slave Uni-TE TCP and/or Modbus TCP/IP
	Standard Web services	Configuration	Via predefined Web pages	
		Diagnostics	Via predefined Web pages: Diagnostics on Ethernet link, serial link, modem link; and diagnostics on e-mail and FDR services	
	Configurable Web services	Read/write	Data editor, “ready-to-use” Web pages: Access to connected device registers	
			HTTP server (8 MB of Flash memory available)	
			Hosting of animated Web pages created by the user and all documents (doc, pdf, etc.) Library of graphic objects (Java applet) with Wizard utility for FrontPage File upload/download via FTP	
	E-mail service		Alarm notification by e-mail (via remote SMTP server)	
	Ethernet TCP/IP advanced communication services	BootP/DHCP protocol	Automatic assignment of IP address, FDR client (replacement of defective product)	
		SNMP	SNMP agent, administration of the device by an SNMP manager	
Security		Miniature firewall on-board (IP address filtering) and password protection		
<b>Connectivity</b>	Ethernet TCP/IP	Physical interface	RJ45 standard 10BASE-T/100BASE-TX connector	
		Data rate	10/100 Mbps with automatic recognition	
	Medium	Twisted pairs		
	Modem	Physical interface	RS 232C link, half- or full-duplex, 57 kbps, 9-way SUB-D connector	
		Services	PPP protocol (incoming and outgoing calls), PAP authentication protocol Remote access via RAS compatible with RTC, GSM, VPN modem	
Serial link	Physical interface	Modbus RS 485 link, max. 115 kbps, standard RJ45 connector	Uni-Telway RS 485 link, max. 19.2 kbps, standard RJ45 connector	
	No. of devices	32 max.		
<b>Characteristics</b>	Operating temperature	0 to + 60°C		
	Relative humidity	10 to 95% non condensing during operation		
	Degree of protection	IP 20		
	Power supply	DC 24 V (limits DC 19.2 to 30 V), 100 mA		
	Conformity to standards	ISO/IEC 8802-3, ANSI/IEEE Std 802.3, EN 61000-6-4, EN 55011 Class A, IEC/EN 61131-2, UL 508, CSA C22.2 No. 142, CSA C22.2 No. 213 Class 1 Division 2 Pending: Marine Merchant certifications		
LED indicators		Modbus activity (RUN Modbus)	Uni-Telway activity (RUN/UTW)	
		Ethernet activity (ETHERNET), gateway error (ERR)		



TSX ETG 1000

TSX ETG 1010

### References

Designation	Routing	Reference	Weight kg
<b>Web FactoryCast Gateway gateways/routers</b> Class C20	Ethernet / Modbus RTU	<b>TSX ETG 1000</b>	0,280
	Ethernet / Uni-Telway	<b>TSX ETG 1010</b>	0,280

#### Presentation

The **174 CEV** ConneXium communication gateways are used for interconnecting the following:

- Modbus/Ethernet TCP/IP for **174 CEV 300 20**
  - Modbus Plus/Ethernet TCP/IP for **174 CEV 200 40**
- by providing multiple ports to adapt to the different architecture.

#### Characteristics



Type of gateway		174 CEV 300 20	174 CEV 200 40	
<b>Transparent Ready services</b>	Class	A10	B10	
	Standard Web services	Configuration	–	Predefined Web pages
		Read/Write	–	Access to connected products list, reading of Modbus Plus devices registers
		Diagnostic	–	Via predefined Web pages: diagnostic on Ethernet and Modbus Plus links
Standard Ethernet TCP/IP communication services		Modbus TCP messaging SNMP Agent		
<b>Functions</b>	Communication gateway	Ethernet/Modbus (many-to-many Modbus)	Ethernet/Modbus Plus (many-to-many Modbus Plus)	
	Interface for programming	Ethernet/Modbus	Ethernet/Modbus Plus	
	Modbus SL (RS 232/RS 485 serial link)	RTU/ASCII frame Data rate 0.3 K...115.2 Kbps	–	
	Modbus Plus (RS 485 network)	–	Token bus, HDLC synchronous mode Data rate 1 Mbps	
Configuration		Local or remote by Telnet in hyper terminal mode	Local or remote (1)	
<b>Interfaces</b>	Ethernet TCP/IP port	Type	1 x 10BASE-T/100BASE-TX	1 x 10BASE-T/100BASE-TX
		Shielded connectors	RJ45	
		Medium	Shielded twisted pair	
	Serial port	Type	1 x Modbus SL	1 x Modbus Plus
Shielded connectors		RJ45	9-way SUB-D connector	
Medium		Shielded twisted pair	Shielded twisted pair (single or double)	
<b>Power supply</b>	Voltage	☰ 9...30 V, ~ 9...24 V	~ 110/220 V (~ 93.5 V...242 V), 47...63 Hz	
	Power consumption	3 W	1 A	
<b>Operating temperature</b>		0...+ 60°C	0...+ 50°C	
<b>Relative humidity</b>		20...90% non condensing	10...95% non condensing	
<b>Degree of protection</b>		IP 20	IP 20	
<b>Dimensions W x H x D</b>		mm (in)	mm (in)	
<b>Weight</b>		kg (lbs)	kg (lbs)	
<b>Conformity to standards</b>		UL, CSA, FM 3611 Class 1 Division 2	UL 508, CSA 142, CE	
<b>LED indicator</b>		Activity, status, diagnostics	Power	

(1) Local with additional keyboard and monitor, via a dedicated screen for basic diagnostic and configuration. Remote, via intuitive Web pages for full configuration and diagnostic.

#### References



Transparent Ready®



174 CEV 300 20

174 CEV 200 40

Description	Transparent Ready class	Functions	Reference	Weight kg
<b>Ethernet/Modbus gateway</b>	A10	- 1 Ethernet port, 10BASE-T/100BASE-TX - 1 Modbus serial link port	<b>174 CEV 300 20</b>	0,500
<b>Ethernet/Modbus Plus gateway/router</b>	B10	- 1 Ethernet port, 10BASE-T/100BASE-TX - 1 Modbus Plus port	<b>174 CEV 200 40</b>	4,260

---

## 5 - Product data sheets

- MV and LV protection & metering products and iMCC motors control-command products *page 92*
  - EGX 100MG gateway . . . . . *page 92*
  - EGX 400MG gateway/server . . . . . *page 93*
- Advanced electrical circuit monitors CM 3000/CM 4000 . . . . . *page 94*
- PowerLogic® SMS electrical power management software . . . . . *page 95*



# Transparent Ready® Products

Electrical distribution products  
MV and LV protection and metering products  
iMCC motors control-command products

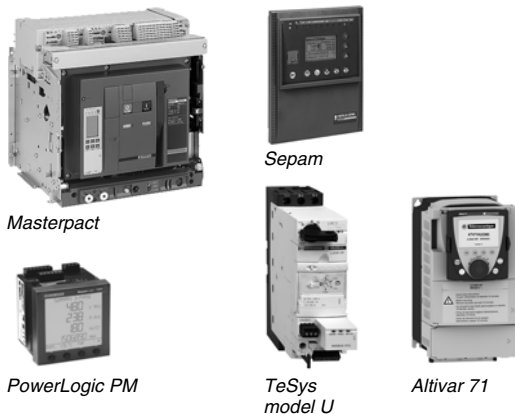

### Presentation

Merlin Gerin communicating electrical distribution protection and measurement products are ideal for integration in Transparent Ready architectures. This range includes in particular:

- Sepam series 20, 40 and 80 Medium Voltage (MV) protection relays.
- Masterpact Low Voltage (LV) circuit-breakers used with their Micrologic A, P or H protection units.
- Power Logic power meters (PM), such as the PM500, PM700 and PM800, that can be used for both MV and LV.
- The advanced Power Logic Circuit Monitors (CM), such as the CM3000 and CM4000.
- The controllers starters TeSys Model U (intelligent motor starters).
- The Altivar variable speed drives.

### Description of the EGX 100MG gateway

These products are connected to Ethernet via the EGX 100 MG gateway that is generally mutualized for a number of electrical distribution and motors control products:

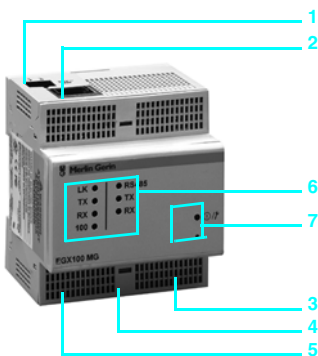

- 1 A screw terminal for connecting the  $\approx$  24 V power supply.
- 2 A standard RJ45 connector for 10BASE-T/100BASE-TX interface.
- 3 A RJ45 connector for Modbus RS 232 serial link.
- 4 A micro switches for 2 or 4-wire RS 485 serial link configuration.
- 5 A 5-way removable terminal block for Modbus RS 485 serial link.
- 6 Seven LED indicators for Ethernet communication (LK, RX, TX, 100), and serial link communication (RS485, RX, TX).
- 7 A LED indicator for  $\approx$  24 V power supply and Reset button.

### Characteristics

Type of gateway		EGX 100MG	
<b>Transparent Ready services</b>	Class	B10	
	Standard Web services	Configuration	Predefined Web pages
		Read/Write	Access to connected products list, reading of Modbus devices registers
		Diagnostic	Via predefined Web pages: diagnostic on Ethernet and Modbus links
	Ethernet TCP/IP communication management services	Modbus messaging	Read/Write Modbus registers of connected devices
SNMP		SNMP Agent, device administration with a SNMP manager	
BOOTP protocol		FDR Client (replacement of defective product)	
Security		Miniature firewall on-board (IP address filtering) and password protection	
<b>Ethernet connectivity</b>	Physical interface	10BASE-T/100BASE-TX (RJ45)	
	Data rate	10/100 Mbit/s with automatic recognition	
	Medium	Twisted pair	
<b>Modbus connectivity</b>	Type of port	RS 485 (2 or 4-wire) or RS 232	
	Protocol	Modbus (RTU and ASCII), PowerLogic - RNIM (Sy/Max)	
	Maxi transmission speed	38,4 Kbps (RS 485), 57,6 Kbps (RS 232)	
	Number of devices	32 max.	
<b>Other characteristics</b>	Operating temperature	- 25 °C to + 70 °C	
	Relative humidity	5...95% non condensing at 40 °C	
	Degree of protection	IP 30	
	Dimensions (W x H x D)	72 x 81 x 76 mm, mounting on symmetrical DIN rail	
	Power supply	$\approx$ 24 V, 4 W or by power supply device PoE ( <i>Power Over Ethernet</i> - IEEE 802.3af)	
	Conformity to standards	UL, cUL (conforming to CSA C22-2 no. 14-M91), UL508, cE	
	Environmental resistance	EN 61000-6-2, EN 61000-4-2/3/4/5/6/8, EN 55022/FCC class A	

### References

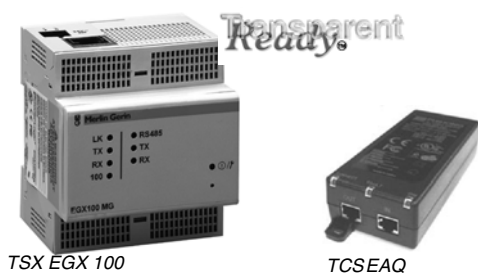

Description	Functions	Reference	Weight kg
<b>Modbus Ethernet gateway/router</b>	Twido, Compact, Momentum, TSX Micro, Altivar, Altistart, Magelis, ... All products compatible with Modbus standard	<b>EGX 100MG ▲</b>	–
Class B 10			
<b>Kit for configuration</b>	Allows gateway configuration through Ethernet or RS 232 port. Comprises RJ45/SUB-D 9 contacts adaptor and a CAT5 twisted pair cable, 3 m length	<b>RJ45 CFG ▲</b>	–
<b>PoE power supply</b> (conform to IEEE 802.3af)	Allows gateway power supply through Ethernet CAT5 cable. Daisy chain power supply connection. Include power supply cable (Australia, Europe, UK and USA)	<b>PSP OE ▲</b>	–

▲ Available later

## Presentation of the EGX 400MG gateway/server

Merlin Gerin communicating products can be connected to Ethernet via the EGX 400MG gateway/server, that is generally mutualized for a number of electrical distribution and motors control products.

The EGX 400MG gateway allows transparent connectivity on Ethernet and profits from Web services associated to products listed above, for easy monitoring of the electric network.

The EGX 400MG gateway also provides Modbus serial link/Modbus TCP/IP gateway services for all Modbus products. It can also take a Modbus master product on one of its ports (configured for this purpose) that will then have access to the Modbus products on the other port.

The EGX 400MG gateway is specifically designed to withstand harsh thermal or electrical environments.

## Description of the EGX 400MG gateway/server

The front side

- 1 A screw terminal for connecting the ~ 24 V power supply.
- 2 Ethernet indication LEDs.
- 3 A 10/100BASE-TX port for connection to Ethernet via an RJ45 connector.
- 4 A 100BASE-FX port for connection to Ethernet via an optic cUL (complying with CSA C22-2 no. 14-M91).
- 5 A terminal block for RS 485 Modbus serial link (COM1).
- 6 COM1 indication LEDs.
- 7 A terminal block for RS 485 Modbus serial link (COM2).
- 8 COM2 indication LEDs.
- 9 Mini-switches for setup of the two configuration ports.
- 10 A SUB-D 9-way connector for connection to the RS 232 serial link.

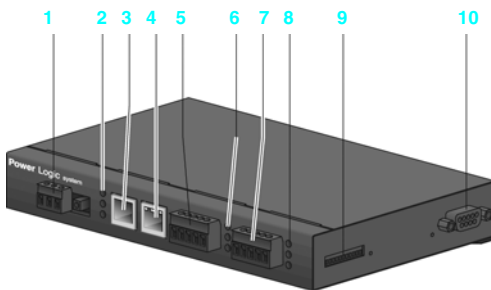

## Characteristics

Type of gateway		EGX 400MG
Transparent Ready services	Class	C10
	Standard Web server	Configuration of the gateway communication functions Monitoring/diagnostics pages associated with the products connected downstream History with graphical display (1). Exports with CSV format (Comma Separated Values) via E-mail, FTP or Microstate Web Query.
	Configurable Web server	Summary Web pages, and ability to record variables (16 Mo possible). Web pages are created using the WPG tool (Web Page Generator), provided with the gateway.
Ethernet TCP/IP communication management service	Ethernet TCP/IP communication management service	Modbus messaging SNMP agent, SNTP time synchronization, HTTP protocol, FTP file sharing
	Ethernet connection	Physical interface
Medium		Twisted pair or optical fiber
Modbus connections	Number of ports	2
	Types of port	Port 1, RS 485 (2 or 4-wire) Port 2, RS 232 or RS 485 (2 or 4-wire)
	Protocol	Modbus
	Transmission speed	38.4 Kbps
	Recommended max. number of devices	32 per port, i.e. 64 in total
Other characteristics	Operating temperature	- 30°C to + 80°C
	Relative humidity	5...95% non condensing at 40°C
	Dimension (W x H x D)	201 x 28 x 123 mm
	Power supply	~ 24 V (~ 100-240 V socket adapter supplied), 8 W
	Conformity to standards	cUL (conforming to CSA C22-2 no. 14-M91), UL508, CE
	Environmental resistance	EN 61000-6-2, EN 61000-4-2/3/4/5/8/11, EN 55022/FCC class A
Mounting	On symmetrical or asymmetrical DIN rail	

## Reference



Description	Functions	Reference	Weight kg
<b>Modbus Ethernet gateway/server</b>	Sepam, Masterpact/Micrologic, PM, CM, TeSys model U, ATV or other Modbus products	<b>EGX 400MG</b>	0.700
Class C 10			
<b>WPG software</b>	Web pages creation	Provided with the gateway	

(1) e.g., maximum recording during 38 days, 6 informations from 32 products, every 15 minutes (possible every 5, 30 or 60 minutes).

# Transparent Ready® Products

Electrical distribution products  
Advanced electrical circuit monitors  
CM 3000/CM 4000



CM 3000/CM 4000

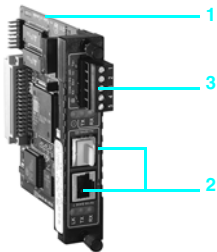

## Presentation

CM 3000 and 4000 Circuit Monitors are high-performance monitoring units that provide a large number of possibilities.  
Installed on the incoming feeder, on the Medium Voltage (MV) or Low Voltage (LV) switchboard incoming supply or on sensitive outgoing feeder, the Circuit Monitors record the electrical parameters of the installation. They provide relevant information for controlling costs, improving power quality and minimizing production downtime. They offer the possibility of detailed recording of the conditions of any detected interference.

Depending on the model and the options, they also perform the following:

- Detection and recording of voltage dips and jumps which cause production stoppages on some sensitive processes.
- Detection and recording of voltage transients: acquisition of currents and voltages adapted to the transients detection: 5 MHz voltage sampling.
- Precise (1 ms) time synchronization by GPS.

They provide current and voltage measurement precision from 0.04% to 0.1%.

## Description

These products are connected to Ethernet via their ECC21 option card. This card also provides an integrated Web gateway/server function to Modbus on Ethernet TCP/IP for Modbus Serial Link communicating products connected downstream:

- 1 ECC 21 Ethernet option card for Circuit Monitor.
- 2 A standard connector for 10BASE-T/100BASE-TX interface (RJ45).
- 3 Modbus serial port for gateway/server function for connecting Modbus products downstream.

The gateway/server function provided by the ECC 21 card is similar to that of the EGX server, but with a lower capacity.

## Characteristics

Type of gateway		ECC 21
Transparent Ready services	Class	C10
	Configurable Web server	Configuration of the CM communication functions and the Modbus TCP/IP gateway function 6 monitoring pages, 5 of which are customizable One page displays details of the electrical values of the host CM The other 5 Web pages (created using the WPG tool) can provide displays of the main electrical values of the Modbus products connected downstream
	Ethernet TCP/IP standard communication management service	Modbus messaging SNMP agent, SNTP time synchronization, SMTP e-mail notification (transmission according to alarms), HTTP protocol, FTP file sharing
Ethernet connection	Physical interface	10BASE-T/100BASE-TX (RJ45) 100BASE-FX
	Medium	Twisted pair or optical fiber
Modbus connections	Number of ports	1
	Type of ports	RS 485 (2 or 4-wire)
	Protocol	Modbus
	Transmission speed	38.4 Kbps
	Recommended max. number of devices	32
Other characteristics	Operating temperature	- 25°C to + 70°C
	Relative humidity	5...95% non condensing at 40°C
	Conformity to standards	C€, UL508
	Environmental resistance	EN 61000-6-2, EN 61000-4-2/3/4/5/8/11, EN 55022/FCC class A

## Reference



ECC 21

Description	For Circuit Monitor metering unit	Reference	Weight kg
Ethernet option card	CM3000 CM4000	ECC21	—
Class C10			

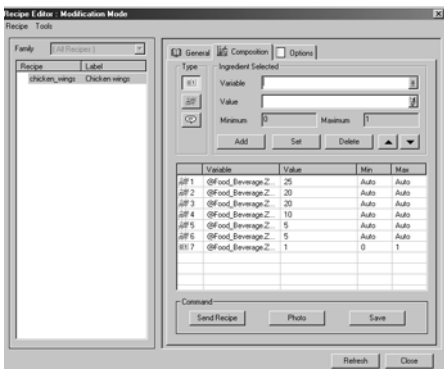

### Presentation

PowerLogic SMS software is a set of software tools specially designed to help the user of an electrical network to control this network and reduce the costs connected with electrical power.

The tools are deliberately simple to configure, and incorporate the library of electrical distribution communicating components, such as Power Meter, Circuit Monitor, Masterpact or Sepam, as standard. They are also open, so that they can handle any type of Transparent Ready product (using Modbus TCP/IP messaging).

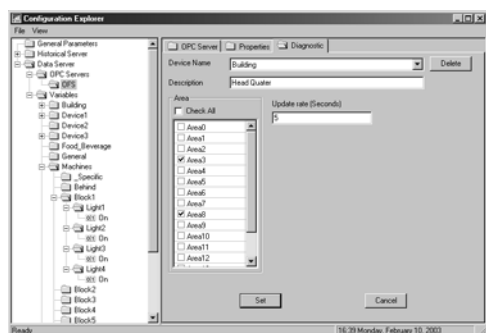

The software offers a large number of pre-defined screens, enabling users to quickly access the electrical data they require. These screens can also be customized.

Using such a tool the user can:

- Ascertain the status of his network.
- View the load curves.
- Optimize his contract with his energy supplier.
- Use submetering and thus accurately re-allocate energy costs.
- Optimize his investment.
- Monitor electricity quality for optimum operation of the network and the process being supplied.

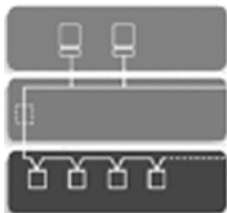

### Description

The SMS software range covers various needs according to functional requirements and type of electrical installation.

### Characteristics, references

Type	PowerLogic SMS, "electrical engineer" supervisory software	
Compatibility	All Merlin Gerin and SquareD electrical distribution products and other Transparent Ready products	
Operating system	Windows 98, Windows 2000 and Windows XP	
Type of software license	Single product	Multi-product
Reference(1)	Electrical Measurement oriented	PMX 1500***
	ED Network management oriented	SMS 1500***

(1) At the end of the reference, add **ENG** for English, **FRA** for French and **ESP** for Spanish.





**6 - Product data sheets**

- Modicon® Momentum™ M1E processor adapters ..... *page 97*
- Twido™ programmable controller ..... *page 98*
- TwidoPort™ interface for Twido controllers ..... *page 99*
- Modicon® TSX Micro Ethernet modules ..... *page 100*
- Modicon Premium™ platform
  - Processors with integrated Ethernet port ..... *page 101*
  - Ethernet modules ..... *page 102*
  - Atrium coprocessors and TCP/IP gateway ..... *page 103*
- Modicon Quantum™ platform
  - Processors with integrated Ethernet port ..... *page 104*
  - Ethernet modules ..... *page 105*
- Preventa™ safety PLCs
  - Compact safety PLCs ..... *page 106*
  - Modular safety PLCs ..... *page 107*
- W@de Remote terminal units for the water sector
  - W330 W@de RTUs ..... *page 108*
  - W315/320 W@de RTUs ..... *page 109*

# Transparent Ready® Products

## Controllers and PLCs

### Modicon Momentum

#### M1E processor adapter with embedded Web server

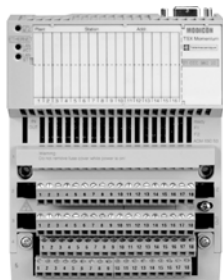

M1E processor adapter on Momentum I/O base



### Presentation

M1 processor adapters with embedded Web server are based on the Modicon Momentum distributed I/O family of products. They are designed to be stand alone for mounting on any discrete, analog or application-specific I/O base. Depending on the type, they take one of the following:

- Remote I/O via the I/O bus port
- Connection of a Modbus master/slave bus.

An optional module inserted between the M1 processor and the I/O base enables these units for network connection. The Flash memory can also be used to back up the applications, creating a local copy of the program to be loaded in the RAM.

Either ProWORX 32 software (LL984 programming) or Concept software (5 IEC languages) is required for programming M1 processor adapters, depending on the model.

### Description

M1E 171 CCC 960 20/30 and 171 CCC 980 20/30 processor adapters have the following on the front panel:

- 1 A standard (RJ45) connector for 10BASE-T interface.
- 2 A 9-way female SUB-D connector for Modbus or I/O bus connection (depending on the model).
- 3 Three LED indicators.

### Characteristics

Type of module	171 CCC 980 20	171 CCC 980 30	171 CCC 960 20	171 CCC 960 30
<b>Transparent Ready services</b>	Class B10			
Web services	"Rack Viewer" access to the product description and status, and to the island diagnostics "Data editor" access to the configuration functions and variables "Web page loader" software tool for loading user Web pages			
Ethernet TCP/IP communication management services	Modbus Messaging (read/write data words) I/O Scanning			
<b>Structure</b>	Physical interface 10BASE-T			
Data rate	10 Mbps			
Medium	Twisted pair			
<b>Network module</b>	Operating temperature 0...+60 °C			
Relative humidity	10...95% non condensing during operation			
Degree of protection	IP 20			
Power supply	Supplied by the 170 A●● I/O base on which the processor is mounted			
Processor scan time	0.3 ms per K instruction			
RAM/Flash memory	512 K/512 K	544 K/1 M	512 K/512 K	544 K/1 M
User memory/data memory	18 K/24 K			
Programming software	ProWORX 32	Concept, ProWORX 32	ProWORX 32	Concept, ProWORX 32
Other communication ports	1 RS 485 Modbus port		1 I/O bus (derived from Interpose)	
Communication extension ports	Via optional modules (1 Modbus Plus port, 1 redundant Modbus Plus port, 1 serial link)			
Conformity to standards	UL, cUL, FM Class 1 Division 2, NEMA type 250, C€			
LED indicators	Adapter operating (RUN) Ethernet network status (LAN Act), Ethernet network activity (LAN STS)			

### References



171 CCC 980/960 ●●

Transparent Ready

Description	Communication ports	Programming	Reference	Weight kg
<b>M1E processors</b>	1 Ethernet,	ProWORX 32	<b>171 CCC 980 20</b>	0.042
	1 Modbus	Concept, ProWORX 32	<b>171 CCC 980 30</b>	0.042
Class B10	1 Ethernet, 1 I/O bus	ProWORX 32	<b>171 CCC 960 20</b>	0.042
		Concept, ProWORX 32	<b>171 CCC 960 30</b>	0.042

Accessories and separate parts: Please consult the "Modicon Momentum automation platform" catalog.

# Transparent Ready® Products

## Controllers and PLCs

### Twido compact base



Twido compact base with display

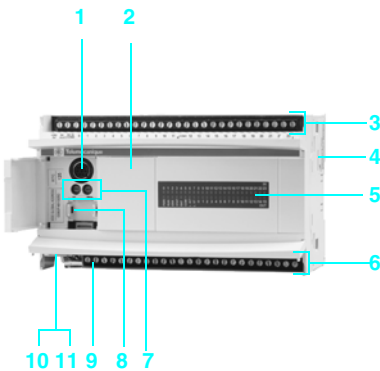

#### Presentation

The Twido range of PLCs provides a compact base with integrated Ethernet port. The TWD LCAE 40DRF base is a compact-sized (95 x 90 x 70 mm), “all-in-one” solution. It uses a 100...240 V~ power supply and has the following discrete I/O:

- 24 x 24 V<sub>DC</sub> inputs
- 14 relay outputs
- 2 x 24 V<sub>DC</sub> transistor outputs.

This base can take:

- Up to 7 I/O expansion modules, thus increasing the I/O capacity to 152 (with screw terminal version) or 264 (with HE 10 connector version)
- All Twido range separate parts (memory cartridge or real-time clock, serial link adapters, digital display).

#### Description

The TWD LCAE 40DRF Twido compact PLC base with integrated Ethernet port consists of:

- 1 An RS 485 serial link port mini-DIN connector (for connecting the programming terminal).
- 2 A slot for diagnostics/maintenance digital display unit.
- 3 Screw terminals for the 24 V<sub>DC</sub> sensor power supply and for connecting the input sensors (protected by hinged terminal covers).
- 4 A connector for expansion modules (7 modules max: discrete I/O, analog I/O, AS-Interface bus).
- 5 An LED display block.
- 6 Screw terminals for connecting the output preactuators (protected by hinged terminal covers).
- 7 Two analog adjustment points.
- 8 A connector for the extension of the 2nd RS 232C/RS 485 serial link port.
- 9 Screw terminals for connecting the 100...240 V~ power supply.

Accessible from beneath the controller:

- 10 A connector for memory cartridge or real-time clock.
- 11 A standard (RJ45) connector for 10BASE-T/100BASE-TX interface.

#### Characteristics

<b>Transparent Ready services</b>	Class	A10
	Web services	No Web server
	Standard Ethernet TCP/IP communication services	Modbus messaging (read/write data words) BOOTP client for allocation of IP addresses via FDR server
<b>Structure</b>	Physical interface	RJ45 standard 10BASE-T/100BASE-TX connector
	Data rate	10/100 Mbps with automatic recognition
	Medium	Twisted pair
<b>Drive</b>	Operating temperature	-0...+55 °C
	Relative humidity	30...90% non condensing
	Degree of protection	IP 20
	Power supply	100...240 V~, 50/60 Hz (limits 85...264 V~, 47...63 Hz)
	24 V <sub>DC</sub> sensor power supply	250 mA
	Inputs	24 x 24 V <sub>DC</sub> , 11 and 7 mA, type 1 inputs (positive or negative logic)
	Outputs	14 x 230 V~ or 30 V <sub>DC</sub> , 2 A relay outputs 2 x 24 V <sub>DC</sub> , 1 A (positive logic) transistor outputs
	Counter	2 x 24 V <sub>DC</sub> 5 kHz channels, 2 x 24 V <sub>DC</sub> 20 kHz channels
	Programming	TwidoSoft (Ladder language, Instruction List), 3000 instructions (6000 with memory cartridge)
	Application memory	3000 instructions (6000 with memory extension cartridge)
	Conformity to standards	IEC 61131-2, UL 508, UL 1604/CSA C22.2 No. 213 (Class 1 Division 2 Groups A, B, C, D), CE and TuV
	LED indicators	Controller status (PWR, RUN, ERR and STAT), I/O (IN <sup>+</sup> /OUT <sup>+</sup> ) Ethernet network status (LAN ST), 10 or 100 Mbps data rate (L ACT)

#### References



TWD LCAE 40DRF

Description	No. of discrete I/O	Reference	Weight kg
<b>Compact base with integrated Ethernet port</b>	24 x 24 V~ inputs 14 relay outputs	<b>TWD LCAE 40DRF</b>	-
100...240 V~ power supply	2 solid state outputs 24 V <sub>DC</sub>		
Class A10			

Separate parts, I/O expansion modules, extension modules, prewired system and TwidoSoft programming software: Please consult our “Automation and relay functions” catalog.

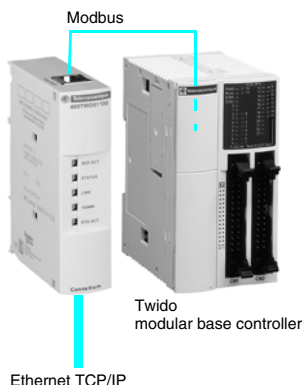

### Presentation

TwidoPort module 499 TWD 01100 is an Ethernet interface that is easy to use and dedicated to a compact or modular Twido programmable controller version ≥ 3.0. It allows incorporation of the Twido controller into an Ethernet network as a passive device (slave). With version 3.0 of TwidoSoft software and of the Twido operating system, the TwidoPort module is ready for use. When connected to the RS 485 port of the Twido programmable controller, the TwidoPort module acts as a gateway between the Ethernet network and the Modbus serial link. The connecting cable is supplied with the module.

- The main characteristics of the TwidoPort module are as follows:
- Connects to the RS 485 port of the Twido controller; no external auxiliary supply is necessary.
  - Ethernet configuration:
    - takes the Ethernet configuration from the Twido application configuration (normal mode),
    - supports manual configuration using Telnet.
  - Provides Ethernet statistics via a Telnet session

An optional type RS 485 link allow to have a second Modbus serial link to connect, for example, a Magelis XBT terminal for operator dialogue. This option is the TWD NAC 485D/485T serial interface adapter.

### Description

- TwidoPort 499 TWD 01100 interface module comprises:
- 1 Five LEDs (SER ACT, STATUS, LINK, 100 MB, ETH ACT) indicating performances associated with the TwidoPort module.
  - 2 An RJ45 connector for connection of the power supply and communications to the RS 485 on the Twido controller, cable TWD XCA RJP03P supplied.
  - 3 An RJ45 connector (accessed through the bottom of the module) for connection to the Ethernet TCP/IP network.
  - 4 An earthing screw (accessed through the bottom of the module).

### Characteristics

Twidoport module		499 TWD 01100
Transparent Ready services	Class	A10
	Web server	None
	Standard Ethernet TCP/IP communication services	Modbus messaging (read/write data words) BOOTP function auto MDI/MDX (no need cross over cable) Telnet for manual configuration and Ethernet statistics
Structure	Physical interface	RJ45 standard 10BASE-T/100BASE-TX connector
	Data rate	10/100 Mbps with automatic recognition
	Medium	Twisted pair
TwidoPort interface	Operating temperature	0...55 °C
	Relative humidity	10...95 % (without condensation)
	Degree of protection	IP 20
	Max. consumption at ~ 5 V	180 mA
	Supply voltage	5 ± 0.5 supplied by compact or modular Twido programmable controller
	Conformity to standards	UL 508, CSA 1010, FCC Class A, EN 61131-2, C€
	LED indicators	Modbus serial link activity (SER ACT), STATUS, Ethernet link status (LINK), 100 Mbps data rate (100 MB), Ethernet network activity (ETH ACT)

### Reference



Description	Characteristics	Reference	Weight kg
<b>TwidoPort interface module</b> for all base controllers version ≥ 3.0	10/100 Mbps. Auto MDIX function. RJ45 connector. TWD XCA RJP03P cable supplied.	<b>499 TWD 01100</b>	0.200
Class A10			

Separate parts, base controllers, I/O expansion modules, extension modules, prewired system and TwidoSoft programming software: Please consult our "Automation and relay functions" catalog.



TSX 37 20 TSX Micro platform

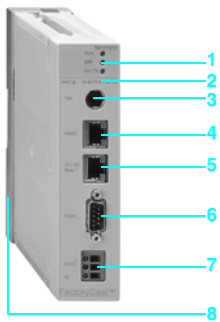

### Presentation

Modicon TSX Micro is the automation platform designed for small machines and mobile systems. It is flexible and modular, offering connections using removable screw terminals or HE10 connectors, and is suitable for applications with up to 248 discrete I/O.

The TSX 37 20 Modicon TSX Micro platform supports the following:

- 4 application-specific functions: counting, position control, analog/process control and safety
- AS-Interface, CANopen, Fipio, Modbus and Uni-Telway buses, and Ethernet, Fipway and Modbus Plus networks.

TSX Micro offers a choice of supply voltages: 24 V<sub>DC</sub> or 230 V<sub>AC</sub>.

### Description

TSX ETZ 410/510 Ethernet modules are autonomous. They are mounted outside the TSX Micro PLC rack, on DIN rails or on AM1-PA pre-slotted plates.

TSX ETZ 410/510 modules have the following on the front panel:

- 1 Three LEDs indicating the module status (RUN, ERR, RX/TX).
- 2 The module MAC address (default factory-set address).
- 3 A mini-DIN connector for connection to the terminal port (marked TER).
- 4 An RJ45 connector for Uni-Telway auxiliary connector RS 485 serial link (marked RS 485).
- 5 A standard RJ45 connector for connection to the Ethernet network (marked 10BASE-T/100BASE-TX).
- 6 A 9-way male SUB-D connector for RS232 serial link (Modem).
- 7 Screw terminals for connecting the 24 V<sub>DC</sub> external power supply.
- 8 A support plate for fixing the module.

### Characteristics

Type of module		TSX ETZ 410	TSX ETZ 510 FactoryCast
Transparent Ready services	Class	B20	C20
	Standard Web services	"Rack Viewer" access to the product description and status and to the PLC diagnostics "Data editor" access to the configuration functions and variables	
	FactoryCast configurable Web services	–	Editor for creating Web page mimics User Web page hosting (8 Mb available)
	Ethernet TCP/IP communication management services	Modbus messaging (read/write data words) FDR client for automatic assignment of the IP address and network parameters SNMP agent, detection of the device by an SNMP manager	
Structure	Physical interface	RJ45 standard 10BASE-T/100BASE-TX connector	
	Data rate	10/100 Mbps with automatic recognition	
	Medium	Twisted pair	
Network module	Operating temperature	0...+60 °C	
	Relative humidity	10...95% non condensing during operation	
	Degree of protection	IP 20	
	Power supply	24 V <sub>DC</sub> (limits 19.2...30 V <sub>DC</sub> ), 100 mA	
	Other TCP/IP communication services	Uni-TE messaging (client/server requests: 128 bytes in synchronous mode and 1 Kb in asynchronous mode)	
	Modem connection	RS 232C link, PPP protocol, Half or Full-Duplex, 56 Kbps	
	Conformity to standards	IEC/EN 61131-2, UL 508, CSA 1010-1, FM Class 1 Division 2, CE	
	LED indicators	Ethernet network status (RUN), transmission/reception activity (TX/RX) Ethernet port fault (ERR)	

### References



TSX ETZ 410/510

Description	Transparent Ready class	Reference	Weight kg
Autonomous Ethernet modules for TSX Micro PLC TSX 37 10/20/30	B20	TSX ETZ 410	0.280
	C20	TSX ETZ 510	0.280
FactoryCast software	FactoryCast configurable Web server	Supplied with TSX ETZ 510	

For further information: Please consult our "Modicon TSX Micro and PL7 software automation platform" catalog.

# Transparent Ready® Products

## Controllers and PLCs

### Modicon Premium

Processors with integrated Ethernet port and embedded Web server

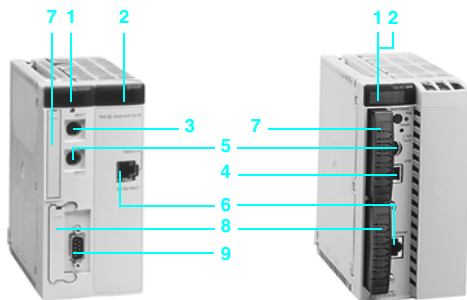

### Presentation

Modicon Premium is the optimized automation platform for complex machines, manufacturing applications and infrastructures. These processors are open to the latest technologies, with integrated universal Ethernet TCP/IP connections. Premium also has numerous advanced automation functions (counting, electronic cam, position control, weighing, process control, data storage and machine safety).

### Description

TSX P57 1634M, TSX P 26●●/2823/36●●/4634/4823/5634M double format processors (1) with integrated Ethernet port include the following on the front panel:

- 1 A display block with 5 LEDs relating to the processor.
- 2 A display block relating to the integrated Ethernet port.
- 3 An 8-way female mini-DIN connector marked TER for connecting a programming or adjustment terminal.
- 4 A USB connector marked TER for connecting a programming or adjustment terminal.
- 5 An 8-way female mini-DIN connector marked AUX for connecting an RS 485 peripheral device.
- 6 A standard (RJ45) connector for 10BASE-T/100BASE-TX interface.
- 7 A slot for a PCMCIA memory extension card.
- 8 A slot for a PCMCIA communication or data storage memory extension card.
- 9 A 9-way SUB-D connector (on TSX P57 2823/4823M models) for Fipio bus manager link.

### Characteristics

Type of module	Unity Pro software PL7 Pro software	TSX P57 1634M	TSX P57 2634M TSX P57 2●23M	TSX P57 3634M TSX P57 3624M	TSX P57 4634M TSX P57 4823M	TSX P57 5634M
<b>Transparent Class</b>		B30				
<b>Ready services</b>	Standard Web services	"Rack Viewer" access to the product description and status and to the PLC diagnostics "Data editor" access to the configuration functions and PLC variables				
	Standard Ethernet TCP/IP communication services	Modbus TCP/IP messaging (read/write data words)				
	Ethernet TCP/IP advanced communication services	I/O Scanning Yes (between 64 stations)				Yes (128 stations)
	Global Data	Yes				
	FDR server	Automatic assignment of IP address and network parameters				
	SMTP e-mail notification	Yes, via Unity Pro function blocks				
	SNMP network administrator	Yes				
	Bandwidth management	Yes				
<b>Structure</b>	Physical interface	10BASE-T/100BASE-TX (RJ45)				
	Data rate	10/100 Mbps with automatic recognition				
	Medium	Twisted pair				
<b>Premium processor</b>	No. of discrete I/O	512	1024		2048	
	No. of analog I/O	24	80	128	256	512
	No. of application-specific channels	8	24	32	64	
	Max. no. of network connections (including integrated link)	1		3	4	5
	Other TCP/IP communication services	Uni-TE TCP X-Way	Client/server requests: 128 bytes in synchronous mode and 1 Kb in asynchronous mode Yes			
	Operating temperature	0...+60 °C				
	Relative humidity	10...95% non condensing during operation				
	Degree of protection	IP 20				
	Power supply	Via the power supply of the rack supporting the processor				
	Conformity to standards	IEC/EN 61131-2, UL 508, CSA 1010-1, FM Class 1 Division 2 Group A/B/C/D, C €				
	LED indicators	Ethernet network status (RUN), transmission/reception activity (TX/RX) Collision detection (COL), Ethernet link diagnostics (STS), Ethernet port fault (ERR) 5 LEDs specific to the operation of the processor (RUN, ERR, I/O, TER and FIP)				

### References



Description	Discrete I/O Analog I/O App-sp. chann.	Reference		Weight kg
		Unity Pro	PL7 Junior/Pro	
Processors with integrated Ethernet link	512 / 24 / 8	TSX P57 1634M	–	0.042
	1024 / 80 / 24	TSX P57 2634M	TSX P57 2623M	0.042
		–	TSX P57 2823M	(2)
Class B30	1024 / 128 / 32	TSX P57 3634M	TSX P57 3623M	0.042
	2048 / 256 / 64	TSX P57 4634M	TSX P57 4823M	(2) 0.042
	2048 / 512 / 64	TSX P57 5634M	–	

(1) Except TSX P57 1634M processor, single format.

(2) Also has an integrated Fipio bus manager link.

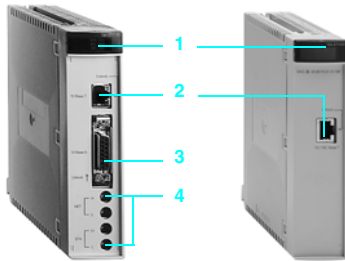

### Presentation

TSX ETY ●●● modules are single format modules which are installed in a rack slot on Modicon Premium PLC stations or Modicon Atrium coprocessors. A configuration can take from 1 to 4 network modules, depending on the type of processor. TSX ETY 110/110 WS/4103/5103 Ethernet modules route X-Way and Uni-TE messages transparently from a TCP/IP network to an X-Way network and vice versa.

### Description

The front panel of TSX ETY ●●● modules comprises:

- 1 A display block indicating the state of the module.
- 2 A standard (RJ45) connector for 100BASE-TX and/or 100BASE-T interface depending on the model.
- 3 A standard connector for 10BASE5 interface (AU1) with TSX ETY 100 WS.
- 4 Four thumb wheels for defining the station number and network number, with TSX ETY 100 WS.

### Characteristics

Type of module		TSX ETY 110 WS FactoryCast	TSX ETY 4103	TSX ETY 5103 FactoryCast	TSX WMY 100 FactoryCast HMI	
Transparent Ready services	Class	C10	B30	C30	D10	
	Standard Web services	"Rack Viewer" access to the product description and status and to the PLC diagnostics "Data editor" access to the configuration functions and variables				
	FactoryCast configurable Web services	Yes	–	Yes	–	
	User Web pages (available size)	Yes (1.4 Mb)	–	Yes (8 Mb)	–	
	FactoryCast HMI active Web services	–	–	–	Yes (1)	
	Standard Ethernet TCP/IP communication services	Modbus TCP/IP messaging (read/write data words)				
	Ethernet TCP/IP advanced communication services	I/O Scanning	–	Yes (between 64 stations)	–	–
		Global Data	–	Yes	–	–
		FDR server	–	Automatic assignment of IP address and network parameters	–	–
		NTP time synchronization	–	–	Yes	–
		SMTP E-mail notification	–	Yes, via Unity Pro function blocks	–	Yes (active Web server)
		SNMP network administrator	SNMP Agent	–	–	–
		SOAP XML Web service ▲	–	–	Server	Client/server
TCP Open		Option	–	Option	–	
Bandwidth management	–	Yes	–	–		
Structure	Physical interface	10BASE-T (RJ45) 10BASE5 (AU1)	10BASE-T/100BASE-TX (RJ45)			
	Data rate	10 Mbps	10/100 Mbps with automatic recognition			
	Medium	Twisted pair	Twisted pair			
	Operating temperature	0...+60 °C				
Network module	Relative humidity	10...95% non condensing during operation				
	Degree of protection	IP 20				
	Power supply	Via the power supply of the rack supporting the processor				
	Other TCP/IP communication services	Uni-TE TCP	Client/server requests: 128 bytes in synchronous mode and 1 Kb in asynchronous mode			–
		Ethway/X-Way	Uni-TE, common words			–
	Conformity to standards	IEC/EN 61131-2, UL 508, CSA 1010-1, FM Class 1 Division 2 Group A/B/C/D, CE				
	LED indicators	Ethernet network status (RUN), transmission/reception activity (TX/RX) Collision detection (COL), Ethernet port fault (ERR)				

### References



TSX ETY 110 WS

TSX ETY ●103/WMY 100

Description	Data rate	Transparent Ready class	Reference	Weight kg
Ethernet TCP/IP modules	10 Mbps	C10	TSX ETY 110 WS	0.370
	10/100 Mbps	B30	TSX ETY 4103	0.340
		C30	TSX ETY 5103	0.340
		D10	TSX WMY 100	0.340
FactoryCast software	FactoryCast server configuration	Supplied with TSX ETY 110WS/5103		
	HMI application development	TLX CD FCHMI V1M		
TCP Open software	TCP Open function block library	TLX CD TCP50M		
	SDKC, Unity applications	UNY SPU ZU CD20E		
	C language development	PL7 applications TLX LSDKC PL741M		

(1) Database management, arithmetic and logic calculations, automatic e-mail transmission on process event, connection to relational databases.

For further information: For further information: Please consult our "Modicon Premium and Unity & PL7 software automation platform" catalog.

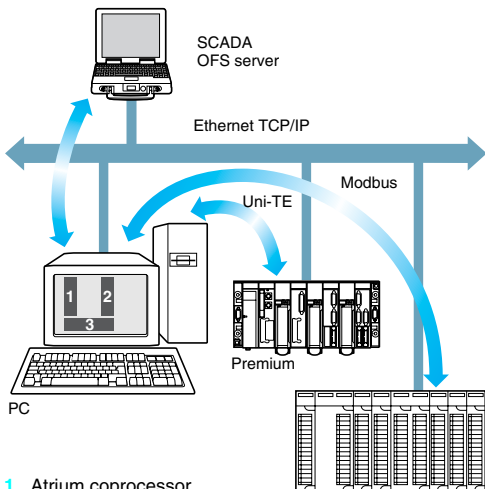
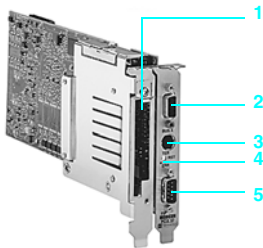

- 1 Atrium coprocessor.
- 2 Ethernet TCP/IP card or integrated port.
- 3 TCP/X-Way software gateway.

#### Presentation

The Atrium coprocessor (PCI bus card), combined with a Magelis iPC industrial PC, provides a PC with a built-in PLC and supervisory software. This type of configuration is designed for installations that require a high level of interaction between the automation functions and the HMI applications. The software gateway enables Atrium PLCs to communicate using Modbus (or Uni-TE) Ethernet TCP/IP via the integrated Ethernet port in the industrial PC.

#### Description of the Atrium coprocessor

TSX PCI 57 204/354M coprocessors occupy two consecutive slots on the PC PCI bus but only use one electrically. They comprise:

- On the faceplate:
  - 1 A slot for a PCMCIA communication or data storage memory extension card.
  - 2 A 9-way female SUB-D connector for connecting Bus X to the first Premium rack supporting the I/O modules and application-specific modules.
  - 3 An 8-way female mini-DIN connector marked TER for connecting a programming terminal.
  - 4 An ERR LED (coprocessor or embedded equipment fault).
  - 5 A 9-way male SUB-D connector (on TSX PCI 57 354M model) for Fipio bus manager communication.
- On the card, component side:
  - 4 or 5 LEDs indicating the operating status
  - A slot for the coprocessor internal RAM backup battery
  - A slot for a PCMCIA memory extension card.

#### Description of the TCP/IP gateway

The TCP/X-Way software gateway performs 2 main functions for Atrium coprocessors:

- Communication using the Modbus (or Uni-TE) TCP/IP protocol via the Ethernet TCP/IP card integrated in the PC
- Data exchange in both directions with remote stations via the telephone modem in the PC.

This software interfaces with the Atrium coprocessor PCIway driver and automatically routes messages. The most common configurations are:

- Via Ethernet network (diagram opposite). Access is made secure by checking incoming IP addresses, in a similar way to the Premium PLC TSX ETY 4103 Ethernet module. The Global Data and I/O Scanning services are not supported.
- Via modem link. Incoming calls are checked via the standard Windows password checking mechanisms. In addition to remote access with Unity Pro, the TCP/IP gateway enables communication with other stations that can be connected to a local Ethernet network (RAS (*Remote Access Server*) function).

#### Characteristics

Type of module	Unity Pro software	TSX PCI 57 204M	TSX PCI 57 454M
<b>Transparent Ready services</b>	Class	A10	
	Standard Web services	No Web server	
	Standard Ethernet TCP/IP communication services	Modbus TCP/IP messaging (read/write data words)	
<b>Structure</b>		That of the Ethernet link integrated in the host PC	
<b>Atrium coprocessor</b>	See characteristics of the Premium processor	TSX P57 2●●●M, page 100	TSX P57 3●●●M, page 100

#### References



TSX PCI 57 204M

TSX PCI 57 454M

Description	Discrete I/O Analog I/O App-sp. chann.	Type of license	Reference	Weight kg
<b>Coprocessors</b>	1024 / 80 / 24	–	<b>TSX PCI 57 204M</b>	0.310
	2048 / 256 / 64	–	<b>TSX PCI 57 454M</b>	0.340
<b>TCP/IP gateway software</b>	–	Single (1 station)	<b>TLX CD GTW 10M</b>	–
	–	Team (10 stations)	<b>TLX CD10 GTW 10M</b>	–
	–	Site (200 stations)	<b>TLX CDUN GTW 10M</b>	–



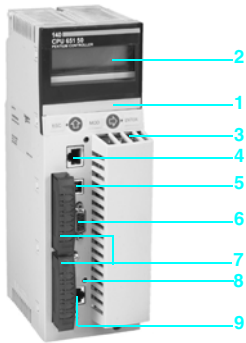

### Presentation

Equipped with a high performance processor, Modicon Quantum is optimized for the control of semi-continuous processes and for high availability requirements. The Quantum platform meets the requirements of the agribusiness, pharmaceutical, metallurgy, chemical-petrochemical and energy-infrastructure sectors.

The new Quantum processors use the latest technologies with integrated Ethernet TCP/IP port, data storage and display unit with keys for local management.

### Description

The 140 CPU 651 50 and 140 CPU 651 60 processors have the following on the front panel:

- 1 An LCD display cover, providing access to:
  - A key switch for locking system operations that may be requested and all the permitted parameters that may be modified via the LCD display (2) and 5-button keypad (3)
  - A slot for the backup battery
  - A "Restart" push button.
- 2 An LCD display (2 lines of 16 characters) with brightness and contrast controls.
- 3 A keypad with 5 buttons (ESC, ENTER, MOD, ÎI, =>) and 2 LEDs.
- 4 An RJ45 connector for connecting to the Modbus bus.
- 5 A female USB B type connector for connecting the programming PC.
- 6 A 9-way female SUB-D connector for connection to the Modbus Plus network.
- 7 Two slots for PCMCIA memory extension cards.
- 8 Two LEDs marked COM and ERR.
- 9 An RJ45 connector for connection to the Ethernet network.

### Characteristics

Type of module		Unity Pro software	140 CPU 651 50	140 CPU 651 60	
<b>Transparent Ready services</b>	Class		B30		
	Standard Web services		"Rack Viewer" access to the product description and status and to the PLC diagnostics "Data editor" access to the configuration functions and PLC variables		
	Standard Ethernet TCP/IP communication services		Modbus TCP/IP messaging (read/write data words)		
	Ethernet TCP/IP advanced communication services	I/O Scanning		Yes (between 128 stations)	
		Global Data		Yes	
		FDR server		Automatic assignment of IP address and network parameters	
		SMTP E-mail notification		Yes, via Unity Pro function blocks	
SNMP network administrator		Yes			
Bandwidth management		Yes			
<b>Structure</b>	Physical interface		10BASE-T/100BASE-TX (RJ45)		
	Data rate		10/100 Mbps with automatic recognition		
	Medium		Twisted pair		
<b>Quantum processor</b>	No. of discrete I/O		Local: 26 slots, decentralized: 31744 I/31744 Q, distributed: 8000 I/8000 Q/network		
	No. of analog I/O		Local: 26 slots, decentralized: 1984 I/31984 Q, distributed: 500 I/500 Q/network		
	Max. no. of communication modules		6 in local rack		
	Max. memory capacities	Program		7168 Kb	
		Localized/non-localized data		512 Kb	1024 Kb (768 Kb with no PCMCIA card)
		Data storage		8192 Kb	
	Operating temperature		0...+60 °C		
Relative humidity		10...95% non condensing during operation			
Degree of protection		IP 20			
Power supply		Via the power supply of the rack supporting the processor			
Conformity to standards		UL 508, cUL, CSA 22.2-142, FM Class 1 Division 2, C€			
LED indicators		Activity on the Ethernet port (COM), collision detection (ERR)			

### References



140 CPU 651 50/60

Description	Processor clock frequency	Program/data capacity (1)	Reference	Weight kg
<b>Processors with integrated Ethernet link</b>	166 MHz	7168 Kb/512 Kb	<b>140 CPU 651 50</b>	-
	266 MHz	7168 Kb/1024 Kb	<b>140 CPU 651 60</b>	-

Class B30

(1) With PCMCIA card.

For further information: Please consult our "Modicon Quantum and Unity, Concept & ProWORX 32 software automation platform" catalog.



### Presentation

Ethernet 140 NOE 771 ●1/NWM 100 00 Ethernet network modules are single format modules for installing in the local rack slots of a Modicon Quantum PLC configuration.

A configuration can take from 2 to 6 application-specific modules, including network modules, depending on the type of processor.

### Description

The front panel of TCP/IP 140 NOE 771 01/771 11 and 140 NWM10000 Ethernet modules comprises:

1 A display block, which indicates the module status and the transmission status on the network.

A hinged cover for access to:

2 A (MT-RJ) connector for 100BASE-FX optical interface.

3 A standard (RJ45) connector for 10BASE-T/100BASE-TX interface.

### Characteristics

Type of module	140 NOE 771 01	140 NOE 771 11 FactoryCast	140 NWM 100 00 FactoryCast HMI
<b>Transparent Class</b>	B30	C30	D10
<b>Ready services</b> Standard Web services	"Rack Viewer" access to the product description and status and to the PLC diagnostics "Data editor" access to the configuration functions and variables		
FactoryCast configurable Web services	–	Yes	
User Web pages (available size)	–	Yes (8 Mb)	
FactoryCast HMI active Web services	–		Yes (1)
Standard Ethernet TCP/IP communication services	Modbus TCP/IP messaging (read/write data words)		
Ethernet TCP/IP I/O Scanning	Yes (between 128 stations)		–
advanced communication services	Global Data	Yes	–
FDR server	Automatic assignment of IP address and network parameters	–	–
NTP time synchronization	–	Yes	–
SMTP e-mail notification	Yes, via Unity Pro function blocks		Yes (active Web server)
SNMP network administrator	Yes		SNMP Agent
SOAP XML Web service ▲	–	Server	Client/server
Bandwidth management	Yes		–
<b>Redundancy service</b>	Compatible with Hot Standby redundant architecture (2)		
<b>Structure</b> Physical interface	10BASE-T/100BASE-TX (RJ45) or 100BASE-FX (MT/RJ)		
Data rate	10/100 Mbps		
Medium	Twisted pair/optical fiber		
<b>Network module</b> Operating temperature	0...+60 °C		
Relative humidity	10...95% non condensing during operation		
Degree of protection	IP 20		
Power supply	Via the power supply of the rack supporting the processor		
Conformity to standards	UL 508, cUL, CSA 22.2-142, FM Class 1 Division 2, CE		
LED indicators	Rack operational (Active), module ready (Ready), network active (Link) Ethernet network status (Run), download mode (Kernel), Full-duplex mode (Fduplex) Transmission/reception activity (TxAct/RxAct), 10 Mbps or 100 Mbps data rate (10MB/100MB) Collision detection (Coll), Ethernet module fault (Fault)		

(1) Database management, arithmetic and logic calculations, automatic e-mail transmission on process event, connection to relational databases.

(2) See "System approach", section 2.5.

### References



Transparent Ready

Description	Data rate	Transparent Ready class	Reference	Weight kg
<b>Ethernet TCP/IP modules</b>	10/100 Mbps	B30	<b>140 NOE 771 01</b>	0.345
		C30	<b>140 NOE 771 11</b>	0.345
		D10	<b>140 NWM 100 00</b>	0.345
<b>FactoryCast software</b>	FactoryCast server configuration		Supplied with 140 NOE 771 11	
	HMI application development		<b>TLX CD FCHMI V1M</b>	–

For further information: Please consult our "Modicon Quantum and Unity, Concept & ProWORX 32 software automation platform" catalog.

140 NOE 771 ●1/NWM 100 00

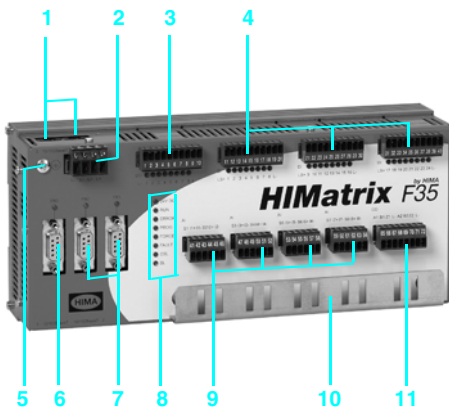

XPS MF 35●2

### Presentation

Preventa XPS MF compact safety PLCs provide a control solution for automated production lines combined with monitoring of the safety functions necessary for the protection of personnel and the safety of machines. They have been developed to meet the requirements of standard SIL 3 according to IEC 61508 and category 4 according to EN 954-1. The range of XPS MF compact safety PLCs is based on 5 small sized PLCs **XPS MF3●●●**, with differing characteristics (number and type of discrete inputs/outputs, communication ports). These Safety PLCs communicate over SafeEthernet with the remote safety I/O modules **XPS MF1/2/3** and various other devices such as graphic terminal, see pages 66 and 67.

### Description

**XPS MF 3022/31222** and **XPS MF 35●●** Preventa compact safety PLCs have the following on the front panel of their metal casing:

- 1 Four RJ 45 (10/100 BASE-T) connectors for connection to SafeEthernet.
  - 2 24 V $\overline{\text{=}}$  power supply removable screw terminals.
  - 3 A terminal for connecting discrete outputs (with one LED per channel).
  - 4 Three terminals for connecting discrete outputs (with one LED per channel).
  - 5 A grounding screw.
  - 6 An FB3 connector (9-way female SUB-D) for connection to the Modbus or Profibus bus (depending on the model).
  - 7 Two FB1 and FB2 connectors (not used).
  - 8 Eight process status LED indicators.
  - 9 Four terminals for connecting analog inputs (1).
  - 10 A plate for fixing the shielded connecting cables for the analog inputs (1).
  - 11 Terminals for connecting 2 counter input channels (1).
- With a spring device on the back panel for rail fixing (1).

(1) Only with XPS MF 35●● model.

### Characteristics

Type of Preventa PLC	XPS MF 3022	XPS MF 31222	XPS MF 3542	XPS MF 3502	XPS MF 3522
<b>Transparent Class</b>	A10				
<b>Ready services</b>	Web services No Web server Standard Ethernet TCP/IP communication services Modbus TCP/IP messaging (read/write data words)				
<b>Structure</b>	Physical interface 100BASE-TX (RJ45) Data rate 100 Mbps full duplex, 10 Mbps half duplex, with auto-negotiation Medium Twisted pair category 5D or better, filter optic cable				
<b>Preventa compact PLC</b>	No. of 24 V $\overline{\text{=}}$ discrete I/O 20 I/8Q (0.5 and 1 A) non isolated 24 I/8Q (0.5 and 1 A) non isolated No. of analog inputs – 8 single pole non isolated (0-10 V, 0-20 mA) No. of 5/24 V $\overline{\text{=}}$ counter inputs – 2 non isolated, 100 kHz No. of connections 4 Ethernet TCP/IP with Modbus and SafeEthernet 2 Ethernet TCP/IP with Modbus and SafeEthernet 4 Bus Modbus serial link – Profibus DP M/SI – Modbus serial link Operating temperature 0...+ 60 °C Relative humidity 10...95% non condensing during operation Degree of protection IP 20 Power supply 24 V $\overline{\text{=}}$ (- 15%...+ 20%) Max. operating category for product Category 4 according to EN 954-1, SIL 3 according to IEC 61508 Conformity to standards IEC 61205, IEC 61131, EN 50156 pending, DIN V 19250, NFPA LED indicators PLC status (24 VDC, RUN, ERROR, PROG, FORCE, FAULT, OSL, BL) Discrete I/O (I $\bullet$ /O $\bullet$ ), SafeEthernet status (RJ45)				

### References



XPS MF 3522



XPS MF 35●2

Description	Inputs & Outputs	Communication	Reference	Weight kg
<b>Compact safety PLCs</b>	20 I/8 Q disc.	SafeEthernet, Modbus slave	<b>XPS MF3022</b>	▲ 1.200
		SafeEthernet	<b>XPS MF31222</b>	▲ 1.000
Class A10	24 I/ 8 Q disc. 8 I analog 2 I counter	SafeEthernet, Modbus slave	<b>XPS MF3522</b>	▲ 0.340
		SafeEthernet, Profibus DP	<b>XPS MF3542</b>	▲ 1.200
		SafeEthernet	<b>XPS MF3502</b>	▲ 1.200

Description	Use	Reference	Weight kg
<b>Software</b>	Development of Preventa PLC applications in Windows	<b>XPS MFWIN</b>	▲ 0.200

For further information: Please consult our "Preventa safety solutions" catalog.

**Nota** : Available later

# Transparent Ready® Products

## Controllers and PLCs

### Preventa modular safety PLCs

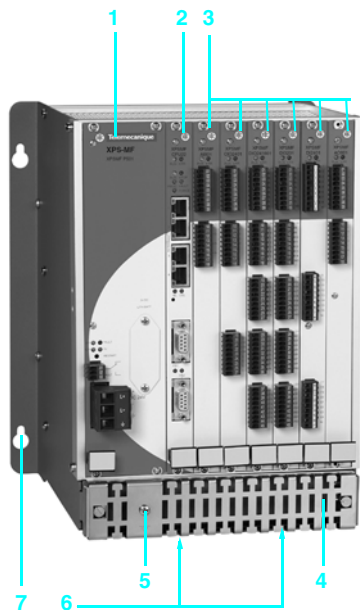

#### Presentation

The Preventa safety PLC **XPS MF60** provides a modular solution for controlling automated lines combined with monitoring of the safety functions necessary for the protection of personnel and machines.

The **XPS MF60** safety PLC has been developed to meet the SIL 3 requirements of standard IEC 61508 and category 4 in accordance with standard EN 954-1.

The **XPS MF60** modular PLC incorporates 4 Ethernet TCP/IP ports as standard and has 6 slots available to take the 7 types of discrete, analog and counter I/O modules. These PLCs use the SafeEthernet protocol for communication with **XPS MF30/31/35** compact PLCs and **XPS MF1/2/3** remote safety I/O modules and various other devices such as graphic terminal, see pages 66, 67 and 106.

#### Description

The Preventa modular safety PLC **XPS MF60** consists of a metal rack with the following:

- 1 A --- 24 V power supply module with Lithium backup battery.
- 2 A CPU.
- 3 Up to six input/output modules.
- 4 A metal plate for mounting the shielded connecting cables of the analog inputs (EMC) with a grounding screw.
- 5 A grounding screw (on a metal plate).
- 6 Two cooling fans (under the rack).
- 7 Four Ø 14 mm oblong holes for mounting the rack on a vertical support.

#### Characteristics

Type of Preventa PLC	<b>XPS MF60</b>	
Services Class	A10	
Transparent Ready Web services	No Web server	
Standard Ethernet TCP/IP communication services	Modbus TCP/IP messaging (read/write data words)	
Structure Physical interface	100BASE-TX (RJ45)	
Data rate	100 Mbps full duplex, 10 Mbps half duplex, with auto-negotiation	
Medium	Twisted pair category 5D or better, filter optic cable	
Preventa modular PLC --- 24 V discrete I/O modules	24 I (--- 24 V isolated, configurables), 32 E (--- 24 V isolated), 8 S relay (~ 230 V/--- 110 V) 24 E (--- 24 V isolated) /16 S (--- 24 V isolated, 2 A)	
Analog I/O modules	8 I single-pole (± 10 V, 0...20 mA) or 4 I double-pole (± 10 V), 8 O (± 10 V, 0...10 V, 0...20 mA)	
Counter module	2 counter inputs (100 kHz, --- 5/24 V) and 4 discrete outputs (--- 24 V isolated, 0,5 A)	
No. of connections Ethernet TCP/IP with Modbus and Safe Ethernet	4	
Bus	Modbus Serial line slave (RS 485, 122 slaves max.)	
Operating temperature	0...+ 60 °C	
Relative humidity	10...95 % non condensing during operation	
Degree of protection	IP 20	
Dimensions (L x H x P) mm	257 x 310 x 245	
Power supply	--- 24 V (- 15 %...+ 20 %)	
Max. operating category for product	Category 4 according to EN 954-1, SIL 3 according to IEC 61508	
Conformity to standards	IEC 61131-2, IEC 61131, EN 50156 pending, DIN V 19250, NFPA	
LED indicators	PLC status (RUN, STOP, ERROR, PROG, FORCE, FAULT, OSL, BL, FB2) SafeEthernet status (RJ45)	

#### References



XPS MFGEH01, XPS MFPS01, XPS MFCPU22, XPS MFDI2401, XPS MFDI3201, XPS MFAI801, XPS MFAO801, XPS MFDO801 and XPS MFDIO241601

Description	Use	Reference	Weight kg
<b>Modular CPU</b> Class A10	4 Ethernet/SafeEthernet integrated 1 Modbus slave integrated	<b>XPS MFCPU22</b>	▲ --
<b>Rack</b>	1 slot for power supply 1 slot for modular CPU 6 slots for I/O modules	<b>XPS MFGEH01</b>	▲ --
<b>Power supply</b>	--- 24 V with "Fault contact" function	<b>XPS MFPS01</b>	▲ --
<b>Input/output modules</b>	24 discrete inputs	<b>XPS MFDI2401</b>	▲ 0,260
	32 discrete inputs	<b>XPS MFDI3201</b>	▲ 0,260
	8 relay outputs	<b>XPS MFDO801</b>	▲ 0,600
	24 discrete inputs/16 discrete outputs	<b>XPS MFDIO241601</b>	▲ 0,260
	8 or 4 analog inputs (sing.or double-pole)	<b>XPS MFAI801</b>	▲ 0,240
	8 analog outputs	<b>XPS MFAO801</b>	▲ 0,280
	2 counter inputs/4 discrete outputs	<b>XPS MFCIO2401</b>	▲ 0,260
Description	Use	Reference	Weight kg
<b>Software</b>	Development of Preventa PLC applications in Windows	<b>XPS MFWIN</b>	▲ 0.200

For further information: Please consult our "Preventa safety solutions" catalog.

▲ Available later

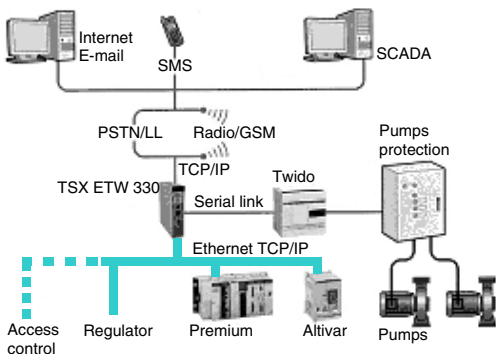

### Presentation

W@de modules are designed principally for remote sites in the water sector or generally for infrastructures. The W330 is a single format standalone module. It can be inserted in a slot of a Modicon Premium PLC or connected to a Twido controller, a Modicon Quantum or TSX Micro PLC

These RTUs can be interfaced to all SCADA or HMI software (compatible with Modbus TCP/IP) and exchange commands between themselves.

The module:

- Detects application process errors by interrogating the PLC.
- Saves and timestamps events and measures.
- Generates alarms and periodic reports via Modem or Ethernet (SMS, ...).
- Easy to configure through an embedded web interface.
- Can be delivered with specialized PLC application examples (water, ...) (1).
- Allows remote programming and remote configuration of the connected PLC.
- Charges and monitors a backup battery (optional or integrated).

### Description

The front panel of **TSX ETW 330** modules comprises:

- 1 A display block indicating the module status.
- 2 An RJ45 normalized connector for 10BASE T/100BASE-TX interface. (Ethernet TCP/IP, Modbus TCP/IP and XIP).
- 3 An RJ45 connector for link to local PLC (RS 232C/RS 485/RS 422, Modbus and Uni-Telway).
- 4 An RJ11 connector for PSTN/ISDN/Leased Line modem (on GSM/GPRS model: a GSM antenna connector below the module).
- 5 Screw terminals for connecting the discrete input/output.
- 6 Screw terminals for connecting the --- 24 V or --- 12 V power supply.

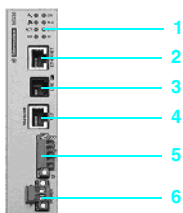

### Characteristics

Type of module		TSX ETW 330G1/330T1
<b>Transparent Ready services</b>	Class	D10
	Standard Web services	Access to PLC variables, alarms, logs and trend curves, file transfers and configuration functions
	Configurable Web services	Creation of dynamic pages with any HTML Editor (3 Mb available)
	Active Web services	Sending SMS messages. SMTP E-mail notification. Log archiving: 140,000 time-stamped data items in battery-backed Flash memory (4 Mb). Alarm management: alarm sending by SMS, E-mail, put-FTP or SNMP-trap, acknowledgment of alarms, pager. Programmable scripts: Alarm summaries, report management (Java script and Visual Basic)
	Standard Ethernet TCP/IP communication services	Transparent access by telephone or GSM/GPRS (PPP) with Unity Pro, TwidoSoft, PL7, ProWORX 32 and Concept software. Modbus TCP/IP messaging (read/write data). Modbus TCP/IP <-> Modbus and XIP <-> Uni-Telway transparent gateway.
	Ethernet TCP/IP advanced communication services	FTP Client/Server: file transmission on a server. NTP time synchronization. Automation protocols: Modbus TCP/IP (messaging and I/O scanning), XIP. SNMP network administration. VPN server compatibility. Security for remote accesses: firewall, IP filtering.
Other communication services	Via serial port	Modbus, Uni-Telway, NetMPI, DF1.
	Via Modem	Modbus TCP/IP, HTTP, FTP, SMTP, NTP, SNMP
	RAS (remote access server)	NAT routing function and "Call Back" function
<b>Structure</b>	Physical interface - data rate	10BASE-T/100BASE-TX (RJ45) (AUI) - 10/100 Mbps with automatic recognition
<b>Other characteristics</b>	Operating temperature	- 25...+ 55 °C (without fan)
	Relative humidity	95 %
	Degree of protection	IP 20
	Power supply	--- 24 V (limits --- 9...30 V)
	Conformity to standards	CISPR/EN 55024, CISPR/EN 55022, IEC 60068-2-1,2,52,78, IEC 60068-2-6-27 UL508 and CSA142 in project Integrated modem standards: PSTN/ISDN R&TTE, FCC Part 68, CS03, GSM R&TTE, GCF
	LED indicators	Power supply (ON), Fault , PLC activity (PLC), modem , Ethernet (LINK), Ethernet activity (ACT), discrete input status (DI), discrete output status (DO)

### References



TSX ETW 330T1

Description	Details	Type of integrated modem	Reference	Weight kg
<b>W330 W@de RTUs</b>	1 input, 1 transistor output	GSM/GRPS	<b>TSX ETW 330G1</b>	-
		PSTN/ISDN/LL	<b>TSX ETW 330T1</b>	-
<b>GSM whip antenna</b>	900 MHz	-	<b>TSX ETW 3GANT1</b>	-
<b>Antenna extension</b>	900/1800 MHz	-	<b>TSX ETW 3GEXT1</b>	-
<b>Power supply and battery charger</b>	20W / --- 24 V	-	<b>TSX ETW 3PWR2 ▲</b>	-

(1) For Modicon PLC application software, please consult our Regional Sales Office or see <http://www.wade-rtu.com> (login: "guest", password: "guest").

▲ Available later

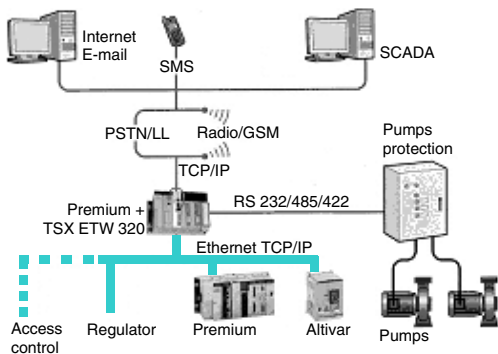

### Presentation

W@de modules are designed principally for remote sites in the water sector or generally for infrastructures. They are standalone modules. They can be inserted in slots of a Modicon Premium PLC or connected to a Twido controller, a Modicon Quantum or TSX Micro PLC.

These RTUs can be interfaced to all SCADA or HMI software (compatible with Modbus TCP/IP, Modbus, DNP3.0, IEC 870-5-101/104) and exchange commands between themselves. The modules:

- Detect application process errors by interrogating the PLC.
- Save and timestamp events and measures.
- Generates alarms and periodic reports via Modem or Ethernet (SMS, ...).
- Easy to configure through a embedded web interface.
- Can be delivered with specialized PLC application examples (water, ...) (1).
- Allow remote programming and remote configuration of the connected PLC.
- Charge and monitor a backup battery (optional or integrated).

### Description

The front panel of **TSX ETW315/320●1** modules comprises:

- A display block indicating the module status.
- An RJ45 normalized connector for 10BASE T/100BASE-TX interface (Ethernet TCP/IP, Modbus TCP/IP and XIP).
- An RJ45 connector for link to local PLC (RS 232C/RS 485/RS 422, Modbus and Uni-Telway).
- An RJ11 connector for PSTN/ISDN/Leased Line modem (with GSM/GPRS model, a GSM antenna connector below the module).
- Screw terminals for connecting the discrete inputs/outputs.
- Screw terminals for connecting the power supply --- 24 V, --- 12 V or ~ 110/230 V with TSX ETW 320●1●1 model.

### Characteristics

Type of module		TSX ETW 320●1●1	TSX ETW 315G1/315T1
<b>Transparent Ready services</b>	Class	B10	
	Standard Web services	Access to PLC variables, alarms, logs and trend curves, file transfers and configuration functions	
	Active Web services	Sending SMS messages. Log archiving: 50,000 time-stamped data items in battery-backed Flash memory (4 Mb). Alarm management: alarms sending by SMS, acknowledgment of alarms, depends on the protocol on modem link	
	Standard Ethernet TCP/IP communication services	Transparent access by telephone or GSM/GPRS (PPP) or Radio or Leased Line with Unity Pro, TwidoSoft, PL7, ProWORX 32 and Concept software. Modbus TCP/IP messaging	
	Ethernet TCP/IP advanced communication services	FTP Client/Server: file transmission on a server. NTP time synchronization. Automation protocols: Modbus TCP/IP (messaging and I/O scanning), CEI 870-5-104, DNP3.0. SNMP network administration. VPN server compatibility	
Other communication services	Via serial port	Modbus	
	Via Modem	Modbus TCP/IP, Modbus, CEI 870-5-101, CEI 870-5-104, DNP3.0	
	Time synchro via Modem	By protocol or by GPS (instead of 2 <sup>nd</sup> Modem location)	By protocol
<b>Structure</b>	Physical interface - data rate	10BASE-T/100BASE-TX (RJ45) (AUI) - 10/100 Mbps with automatic recognition	
<b>Other characteristics</b>	Operating temperature	- 25...+ 70 °C (without fan)	
	Relative humidity	95 %	
	Degree of protection	IP 20	
	Power supply	~ 110/230 V and/or --- 12 V battery	--- 24 V (limits --- 9...30 V)
	Conformity to standards	CISPR/EN 55024, CISPR/EN 55022, IEC 60068-2-1,2,52,78, IEC 60068-2-6-27 UL508 and CSA142 in project Integrated modem standards: PSTN/ISDN R&TTE, FCCpart68, CS03, GSM R&TTE, GCF	
LED indicators	Power supply (ON), Fault , PLC activity (PLC), modem , Ethernet (LINK), Ethernet activity (ACT), discrete input status (DI), discrete output status (DO)		

### References (2)

Description	Width	Discrete I/O number	Type of integrated modem	Reference	Weight kg
<b>W@de W315 RTUs</b>	Simple	-	GSM/GPRS	<b>TSX ETW 315G1 ▲</b>	-
			PSTN/ISDN/LL	<b>TSX ETW 315T1 ▲</b>	-
			Radio	<b>TSX ETW 315R1 ▲</b>	-
<b>W@de W320 RTUs with 2 integrated modems</b>	Double	6 I/O transistor configurables by group of 2	PSTN/ISDN/LL, Radio	<b>TSX ETW 320T1R1 ▲</b>	-
			PSTN/ISDN/LL, GSM/GPRS	<b>TSX ETW 320T1G1 ▲</b>	-
			PSTN/ISDN/LL, RS 232	<b>TSX ETW 320T1S1 ▲</b>	-
			PSTN/ISDN/LL, GPS synchro	<b>TSX ETW 320T1P1 ▲</b>	-
			GSM/GPRS, GPS synchro	<b>TSX ETW 320G1P1 ▲</b>	-

(1) For Modicon PLC application software, please consult our Regional Sales Office or see <http://www.wade-rtu.com> (login: "guest", password: "guest").

(2) Accessories, see page 108.

▲ Available later

---

## 7 - Product data sheets

- Magelis™ graphic terminals
  - XBT GT/XBT G touch screen graphic terminals ..... page 112
  - XBT F graphic terminals ..... page 112
- Magelis™ iPC industrial PCs
  - Smart and Compact ..... page 113
  - Modular ..... page 114
- FactoryCast™ HMI application development software ..... page 115
- Vijeo™ Look SCADA software ..... page 116
- Monitor V7.2 SCADA software ..... page 117
- OFS data server software ..... page 118

#### Presentation

Magelis XBT GT (with 3.8" LCD touch screen), Magelis XBT G (with 5.7" to 12.1" LCD touch screen) and Magelis XBT F (with keypad or 10.4" touch screen) graphic terminals provide simple access to communication solutions via their direct connection to the Ethernet TCP/IP network.

#### Characteristics and references

Transparent Ready



Touch screen graphic terminals		Magelis XBT GT	Magelis XBT G			
Display	LCD screen size	3.8"	5.7"	7.4"	10.4"	12.1"
Functions	Representation of variables	Alphanumeric, bitmap, bargraph, gauge, button, light, clock, flashing light, keypad				
	Curves	Yes, with log				
	Alarm log	Yes, incorporated				
Communication	Integrated Ethernet	10BASE-T (RJ45)				
	Downloadable protocols	Uni-TE, Modbus, Modbus TCP/IP and third-party protocols				
Compatibility with PLCs		Twido, Modicon TSX Micro, Modicon Premium, Modicon Quantum				
Configuration software		Vijeo Designer VJD S●D/G●D/T●D V42M (on Windows 2000 and XP)				
Compact Flash card slot		—	Yes			
Dimensions	W x H x D (mm)	130 x 104 x 41	171 x 138 x 60	215 x 170 x 60	317 x 243 x 58	
Supply voltage		— 24 V				
References	Back-lit B & W monochrome STN screen	XBT GT1130 (1)	XBT G2130	—	—	—
	64-color STN screen	—	—	—	XBT G5230	—
	256-color TFT screen	—	XBT G2330	XBT G4330	XBT G5530	XBT G6330

Transparent Ready

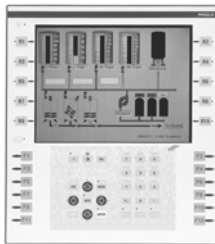

Graphic terminals		Magelis XBT F				
Display	LCD screen size	10.4"				
Data entry keypad	Soft function keys with LED	10			—	
	Static function keys with LED	12 + legends			—	
	Service keys	12			—	
	Alphanumeric keys	12 + 3 alphanumeric access			—	
Touchscreen data entry		—			Yes	
Functions	Representation of variables	Alphanumeric, bitmap, bargraph, gauge, potentiometer, selector				
	Recipes	125 records maximum with 5000 values				
	Curves	16				
	Alarm log	Yes				
Communication	Integrated Ethernet	10BASE-T/100BASE-TX (RJ45)				
	Buses and networks	Fipway, Modbus Plus, and third-party protocols				
	Downloadable protocols	Uni-Telway, Modbus, Modbus TCP/IP				
Compatibility with PLCs		Twido, Nano, Modicon TSX Micro, Modicon Premium, Modicon Quantum				
Configuration software		XBT L1003M (on Windows 98, 2000 and XP)				
Dimensions	W x H x D (mm)	296 x 91 x 322			296 x 91 x 222	
Supply voltage		— 24 V				
References	256-color TFT screen	XBT F024610			XBT F034610	

Separate parts						
Magelis XBT G graphic terminals	Compact Flash memory cards	64 Mb	128 Mb	256 Mb	512 Mb	—
	Module for connection to	—	—	—	—	Modbus Plus network
References		XBT ZGM64	XBT ZGM128	XBT ZGM256	MPC YN0 OCFE 00N	XBT ZG MBP
Magelis XBT F graphic terminals	PCMCIA memory card	16 Mb			—	—
	PCMCIA card for connection to	—			Fipway network	Modbus Plus network
References		XBT MEM16		TSX FPP 20	TSX MBP 100	

(1) With 6 function keys R1...R6.

For further information, please consult our "Human-Machine Interface" catalog.



#### Presentation

Magelis Smart iPC and Compact iPC industrial PCs are characterized by their compact size, their simplicity and their speed of setup. They use the latest Ethernet TCP/IP and Web client connection technologies.

Smart iPC and Compact iPC industrial PCs have a 15" TFT active matrix back-lit color LCD touchscreen. They include:

- An Ethernet 10BASE-T/100BASE-TX port (RJ45 connector)
- Web browser software tools (Internet/Intranet)

Also included, depending on the model:

- Smart iPC, a hardened PC with no vulnerable components (hard disk, CD-ROM drive, etc.) to be used as Web client. It includes:
  - Windows XPe operating system
  - A client for Windows Terminal Services client/server architectures
  - Software (Readers) for reading Word (.doc), Excel (.xls), PowerPoint (.ppt) and Acrobat (.pdf) files.
- Compact iPC, an industrial PC with a hard disk (> 20 MB) and CD-ROM and floppy disk drives.

#### Characteristics and references



Compact industrials PCs		Smart iPC	Compact iPC
Display	Size	15" XGA (1024 x 768)	
	Format	TFT active matrix back-lit color LCD (262,144 colors)	
Data entry		Via touchscreen	
Processor	Format	VIA	Intel Pentium 4 Mobile
	Frequency	667 MHz	1.7 GHz
Internal hard disk		–	≥ 20 Gb IDE, 2 ½"
RAM		250 Mb expandable to 512 Mb (1 memory slot max.)	
CD-ROM drive		–	Yes, 24x
Expansion slots		2 PCMCIA slots	1 PCI bus slot, 2 PCMCIA slots 1 Compact Flash slot
Ethernet TCP/IP network		1 x 10BASE-T/100BASE-TX (RJ45)	
Operating system		Windows Xpe integrated	Windows 2000 pre installed
I/O ports		2 x USB, 1 x COM1, 1 x COM2, 1 x LPT1 (parallel), 1 x PS/2 keyboard	2 x USB, 1 x COM1, 1 x COM2, 1 x COM3, 1 x LPT1 (parallel), 1 x PS/2 keyboard and 1 x PS/2 mouse
	On front panel	–	1 x USB
Fixing		Fixings included with each product for mounting on panel or enclosure door	
Dimensions	W x H x D (mm)	395 x 294 x 67 mm	395 x 294 x 100 mm
Power supply		24 V	~ 115...230 V
References		MPC ST5 2NDJ 00T	MPC KT5 2NAA 00N      MPC KT5 5NAA 00N

Compact iPC and Vijeo Look software combined offer			
Type of processor	VIA 667 MHz	Pentium 4 Mobile 1.7 GHz	
Vijeo Look supervisory software(1)	Run Time (RT)	Run Time (RT)	Build Time/Run Time (BT/RT)
References	MPC KT5 2NAA 00A	MPC KT5 5NAA 00A	MPC KT5 5NAA 00B

Separate parts			
Description	512 Mb Compact Flash memory	512 Mb memory extension for VIA 667 MHz	512 Mb memory extension for Pentium 4 Mobile 1.7 GHz
References	MPC YN0 0CFE 00N	MPC YN0 2RAM 512	MPC YN0 5RAM 512

(1) See page 116.

For further information, please consult our "Human-Machine Interface" catalog.

#### Presentation

The modularity and flexibility of the Magelis Modular iPC range enables you to choose the ideal solution for your HMI requirements on a PC base, with easy upgrading and fast maintenance:

- IP 65 front panels: 12" or 15" color TFT LCD screen, with or without touchscreen capability, and with or without QWERTY keyboard.
  - Control boxes, with varying power and expansion capabilities.
- As standard, the Control boxes include an Ethernet 10/100 Mbps port, two USB ports, the various standard serial and parallel ports, and up to 6 PCI/ISA bus slots.

#### Characteristics and references



Screens for Modular iPC industrial PCs (any screen can be used with any type of Control box)

<b>Display</b>	LCD screen size	TFT active matrix back-lit (262,144 colors)		
<b>Data entry</b>	By	Keypad	Keypad and touchscreen	Touchscreen
	Alphanumeric keys	70 standard IBM keys		–
	User function keys	2 x 10 keys		–
<b>Input/output ports and device on front panel</b>		1 IrDA infrared port, 1 PS/2 port for keyboard/mouse and pointing device		
<b>Combination</b>		With any of the Control boxes listed below		
<b>Dimensions</b>	Screen size 12"	410 x 330 x 52.7 mm		380 x 330 x 52.7 mm
	Screen size 15"	480 x 370 x 52.7 mm		460 x 340 x 52.7 mm
<b>References</b>	Screen size 12"	MPC NA2 0NNN 00N	MPC NB2 0NNN 00N	MPC NT2 0NNN 00N
	Screen size 15"	MPC NA5 0NNN 00N	MPC NB5 0NNN 00N	MPC NT5 0NNN 00N

Transparent Ready.



Control boxes	Small	Medium	Large		
<b>Processor</b>	Intel Celeron 566 MHz	Intel Pentium III 850 MHz	Intel Celeron 566 MHz	Intel Pentium III 850 MHz	Intel Pentium III 850 MHz
<b>Internal hard disk</b>	> 20 Gb	> 20 Gb, removable			
<b>RAM</b>	SDRAM 256 Mb, expandable to 512 Mb (2 memory slots maximum)				
<b>CD-ROM drive</b>	Optional	Removable, 24x			
<b>Floppy disk drive</b>	3½", 1.44 Mb	3½", 1.44 Mb, removable			
<b>Expansion slots</b>	–	3 slots (1 ISA bus, 1 PCI bus and 1 PCI/ISA bus)	6 slots (2 ISA bus, 3 PCI bus and 1 PCI/ISA bus)		
<b>Integrated Ethernet TCP/IP port</b>	1 x 10BASE-T/100BASE-TX (RJ45)				
<b>I/O ports</b>	2 x USB, 2 x COM, 1 x parallel, 1 x external VGA screen, 1 x PS/2 keyboard, 1 x PS/2 pointing device				
<b>Combination</b>	With any of the above types of screen or for use on its own (in this case, use the MPC NP0 0NNN 00N mounting panel)				
<b>Operating system</b>	Windows 2000 pre-installed				
<b>Dimensions</b>	W x H x D (mm)	310 x 310 x 94.2	310 x 310 x 184.5	310 x 310 x 258	
<b>References</b>	~ 115...230 V power supply	MPC AN0 2NAA 00N	MPC BN0 2NAA 00N	MPC CN0 5NAA 00N	MPC CN0 2NAA 00N
	~ 24 V power supply	MPC AN0 2NDA 00N	MPC BN0 2NDA 00N	MPC BN0 5NDA 00N	MPC CN0 2NDA 00N

Modular Magelis iPC-Vijeo Look software combined offers	Small	Medium	Large
<b>Processor</b>	Intel Celeron, 566 MHz		
<b>Vijeo Look supervisory software</b> (see page 115)	Run Time (RT)		Build Time/Run Time (BT/RT)
<b>References</b> ~ 115...230 V power supply	MPC AN0 2NAA 00A	MPC BN0 2NAA 00B	MPC BN0 2NAA 00C
<b>Separate parts</b>	RAM memory extension		Remote front panel screen kit
<b>Description</b>	64 MB	128 MB	256 MB
<b>References</b> ~ 115...230 V power supply	MPC YN0 0RAM 064	MPC YN0 0RAM 128	MPC YN0 0RAM 256
			MPC YN0 0R●● KIT (1)

(1) Replace ●● with 05 for remote cable 5 m, with 10 for 10 m, with 20 for 20 m.

# Transparent Ready® Products

## Human-Machine Interface products

### Web application development, FactoryCast HMI software

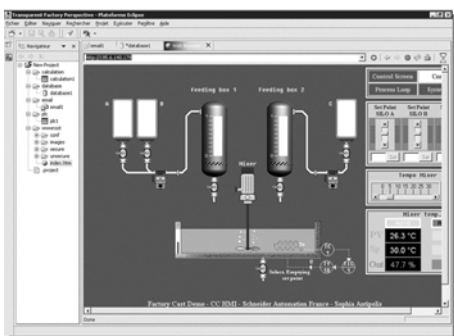

#### Web application development, FactoryCast HMI software

FactoryCast HMI application development software, referenced TLX CD FCHMI V1M, provides multiproject management and complete control of FactoryCast HMI applications, during both the development and the debugging phases, thanks to the online mode and simulation mode (operational when the system is offline) options.

This software enables the intuitive and user-friendly setup of HMI functions by simply setting parameters using a tree structure of the application and can be used for complete management of the Web site:

- Setting parameters for HMI functions:
  - Configuration of PLC interfaces: Import symbol databases and set parameters for the acquisition period
  - Configuration of spreadsheets
  - Configuration of E-mail
  - Configuration of connections to databases
  - SOAP/XML client /server interface (see pages 32 and 33)
  - Recipe management
- Management of the Web site:
  - Management of the Web site tree structure (creation/deletion of HTML folders and files)
  - Management of default Web site pages
  - Management of user Web site pages (1)
  - Graphic object editor for animating Web pages
  - Launch of the system editor for HTML pages (FrontPage or similar)
  - Up/downloading/comparison of Web pages in online mode
  - Debugging of Web pages in online mode or in simulation mode (including animations and Java beans)

- Simulation mode
 

The application and the Web site (including animations and Java beans) can be debugged in either online or simulation mode, which enables operation to be tested without a FactoryCast HMI module and without a physical connection to a PLC, thus simplifying debugging.

An integrated graphics editor in the FactoryCast HMI software can be used to easily customize the following graphic objects: bar charts, gauges, LEDs, curves, cursors, operator input fields, alphanumeric display fields, buttons, etc.

User Web pages are created graphically using an external HTML editor (FrontPage or similar, not supplied).

FactoryCast HMI includes a plug-in for FrontPage 2000. This plug-in makes it easier to set up animations, which enable PLC variables to be accessed in real-time in the HTML pages created by the user. They are created in the HTML editor by simply inserting customized graphic objects (FactoryCast Java beans).

(1) Creation of user Web pages: User Web pages created in the FactoryCast HMI environment are actual animated supervision screens and can be used to monitor your process. Based on HMI Web technology, they enable real-time access to PLC variables thanks to the FactoryCast graphic objects library (FactoryCast Java beans).



TSX WMY 100



140 NWM 100 00

#### References

##### FactoryCast HMI modules

Active Web server	Module for automation platform	Data rate	Reference	Weight kg
FactoryCast HMI	Modicon Premium	10/100 Mbps	TSX WMY 100	0.340
	Modicon Quantum	100 Mbps	140 NWM 100 00	-

##### FactoryCast HMI installation software (to be ordered separately)

Name and description	Use	Operating system	Reference	Weight kg
Multilingual FactoryCast HMI (1)	Development and debugging of the HMI application	Windows 2000, Windows XP	TLX CD FCHMI V1M	0.340

(1) Includes documentation in electronic format.

# Transparent Ready® Products

## Human-Machine Interface products

### Vijeo Look control software



#### Presentation

Vijeo Look version 2.5 is a SCADA (Supervisory Control And Data Acquisition) software package designed for standalone stations. It is based on open, standardized technologies, similar to Transparent Ready products. For example, it provides the ability to display pages in Modicon PLC embedded Web servers.

It is easy to implement and offers all the standard functions of a graphic supervision tool. Vijeo Look is supplied with a pre-configured OFS (*OPC Factory Server*, see page 117) data server. It is compatible with PCs running Windows 2000 Professional or Windows XP Professional, and is used for creating applications based on Telemecanique Twido, Modicon TSX Micro, Modicon Premium/Atrium/Momentum/Quantum PLCs.

The functions of Vijeo Look supervisory software can be used for:

- Acquisition of PLC tags
- Visualization of these tags
- Process supervision and control
- Recording the values of PLC tags or internal process tags in a database
- Embedded software processing

PLC tags are acquired exclusively by connecting to the PLCs via the OPC server, supplied with the OFS data server software included with Vijeo Look. In the case of discrete and analog I/O tags from TSX Micro/Premium/Quantum PLCs (and Advantys STB/Momentum/TBX remote I/O), the acquisition process in the Vijeo Look database takes place in an implicit, transparent manner. As an OPC server, Vijeo Look enables you to create and enhance tags, as well as make them available.

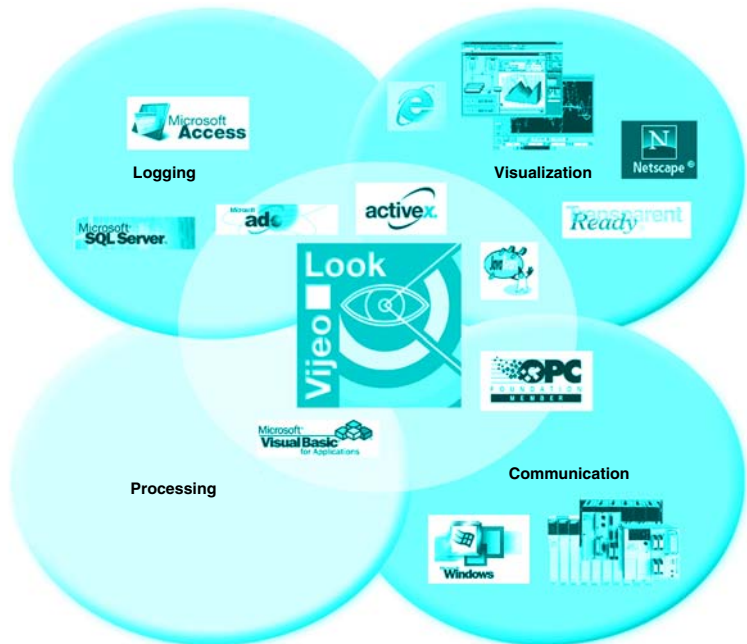
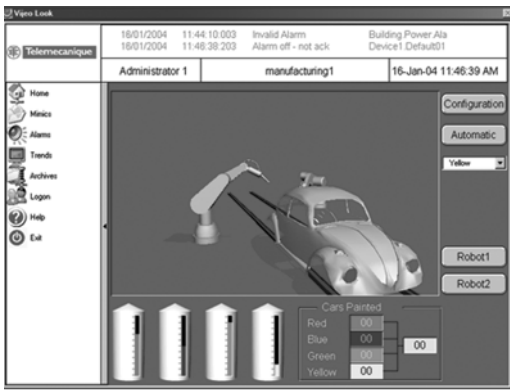

#### Structure of the offer

The Vijeo Look offer includes 2 types of software license:

- Build Time/Run Time license (*BT/RT*) allowing the application to be built and run
- Run Time license (*RT*) allowing the application built with the RT/BT license to run

There are four I/O sizes offered for each license type: Small (128 I/O), Medium (512 I/O), Large (1024 I/O) and Extra Large (2048 I/O).

#### References

Vijeo Look software				
Compatibility	Twido, Modicon TSX Micro/Momentum/Premium/Atrium/Quantum PLCs			
Operating system	Windows 2000 Professional or Windows XP Professional			
Type of license	Small, 128 I/O	Medium, 512 I/O	Large, 1024 I/O	Extra Large, 2048 I/O
References	Build Time/Run Time (BT/RT)	VJL SMD BTS V26M	VJL SMD BTM V26M	VJL SMD BTL V26M VJL SMD BTX V26M
	Run Time (RT)	VJL SMD RTS V26M	VJL SMD RTM V26M	VJL SMD RTL V26M VJL SMD RTX V26M

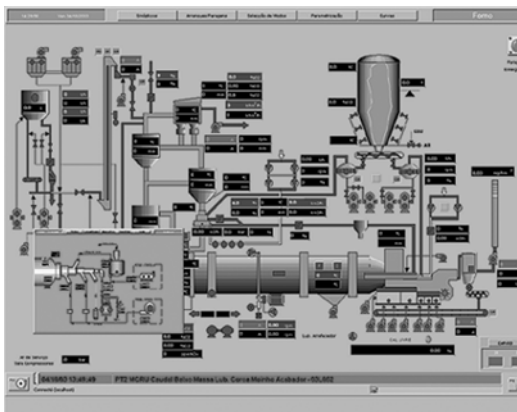

#### Description

Monitor Pro V7.2 is a SCADA (Supervisory Control and Data Acquisition) software solution. Its high-performance real-time server offers excellent processing capability, mainly due to the application objects. In addition, its client-server architecture on Ethernet TCP/IP enables it to be easily integrated in architectures based on Transparent Ready products: multi-server for sharing processing, multi-user for wide distribution of information, or in redundancy mode for your “high availability” applications.

- **The graphic interface** offers a library of graphic objects. Based on Windows technology, the interface is easy to customize.
- **Configuration Explorer:** an intuitive environment for configuring the real-time data server and for object-oriented configuration.
- **The relational database access interface,** supplied with SQL Server 2000. Monitor Pro V7.2 makes it easy to record production data or access stored information. Monitor Pro V7.2 also operates with Oracle, Sybase, Dbase IV and all other databases that support the ODBC standard.
- **Improved availability:** Monitor Pro incorporates redundancy services ensuring a high level of architecture availability.
- **Integrated traceability functions,** for real-time monitoring of the quality of your production as well as logging all the actions of the operators.

Monitor Pro V7.2 is the supervisory software package that adapts to your needs. It offers you real-time production monitoring and enables you to optimize the use of your equipment.

#### Multi-level architecture

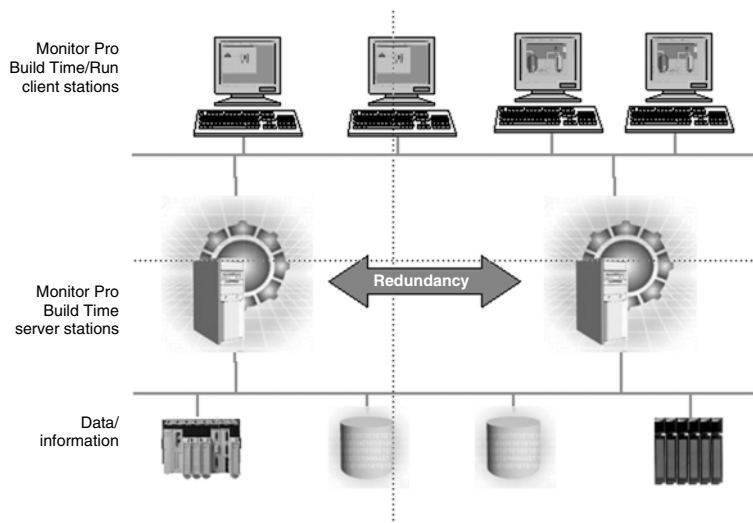

#### Characteristics

<b>Format</b>	<b>Control software</b>
<b>Compatibility</b>	All Telemecanique PLCs and all automation systems on the market via communication drivers or using the OPC standard
<b>Operating system</b>	Windows 2000 service Pack 3, Windows XP or Windows Server 2003
<b>Input/Output size</b>	11 sizes, from 300 I/O to an unlimited number of I/O (from 4800 tags to an unlimited number)
<b>Version</b>	Build Time/Run Time (BT/RT) or Run Time (RT)
<b>PC CD-ROM references</b>	Please contact your Regional Sales Office

# Transparent Ready® Products

## Human-Machine Interface products

### OFS data server software

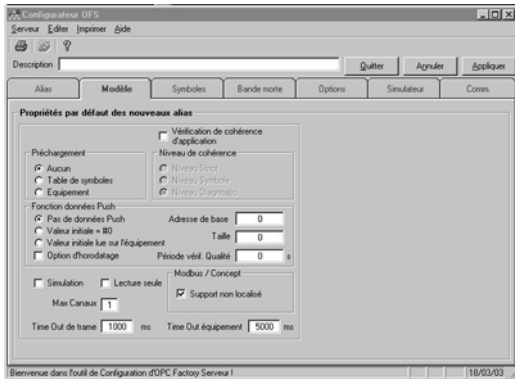

#### Description

OFS (OPC Factory Server) version 3.0 software uses the OPC (OLE for Process Control) standard that allows “Client” applications (supervisors, databases, spreadsheets) to access control system data:

- Modicon Premium/Quantum PLC internal variables (words, bits) and I/O.
- Internal variables (words, bits) only on Modicon TSX Micro, Modicon Momentum/Quantum (with Concept/ProWORX software), TSX Series 7 and April PLCs.
- Modbus devices connected to gateways of Schneider Electric group (TSX ETG, EGX, ...).

OFS software is a multi-PLC data server, that enables several communication protocols to be used, by providing client applications with a set of services for accessing automation system variables.

This software is aimed at two types of user in particular:

- “End” users who want to develop applications on PCs and require access to PLC data. In this context it is possible, for example, to create client applications (supervisory control screens, Excel spreadsheets, etc) with access to a number of PLCs connected via Ethernet to the PC supporting these applications.
- Developers of industrial automation or IT products (supervision, human-machine interfaces, etc) who wish to develop client applications in their products to access the data contained in Telemecanique PLCs via the OPC server.

OFS software can be integrated in control system architectures as shown below:

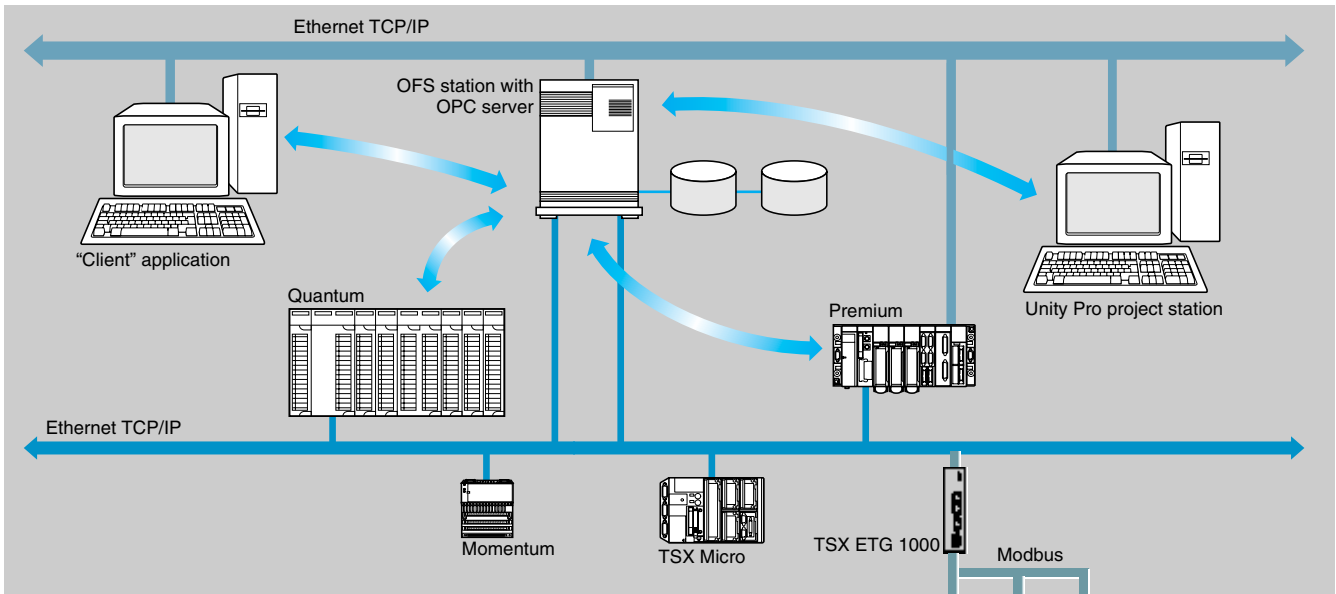

#### Structure of the offer

The OFS offer comprises:

- An OPC server configuration tool.
- OPC server software that receives requests from an OPC client and re-transmits them using Ethernet TCP/IP to the PLCs.
- Drivers for communication with Modicon PLCs.
- An OPC client for verifying the client/server communication between the various connected elements.
- A simulator for verifying the operation of the client(s) without a connected PLC.
- Setup documentation in electronic format.

#### References

##### OFS data server software

<b>Compatibility</b>	All Modicon TSX Micro/Momentum/Premium/Quantum and TSX Series 7/April PLCs		
<b>Operating system</b>	Windows 2000 Professional or Windows XP		
<b>Type of license</b>	Single station	10 stations	200 stations
<b>References</b>	Development of client applications accessing data on Telemecanique PLCs via OPC	TLX CD OFS 30M	TLX CD 10OFS 30M
			TLX CD UNOFS 30M

---

## 8 - ConneXium product data sheets

- Hubs ..... page 120
- Transceivers ..... page 121
- Switches ..... page 122
- IP 67 switch and cables ..... page 124
- Shielded twisted pair and fiber optic cables ..... page 125

### Presentation

Hubs (or concentrators) are used for transmitting signals between several media (ports). Hubs are “plug and play” devices that do not need any configuration. The use of hubs (or concentrators) makes it possible to create the following topologies:

- Star topology using hubs.
  - Tree topology using hubs.
- See “Cabling system” page 55.

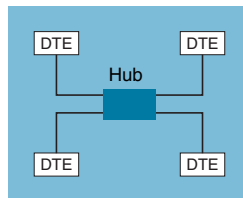

Star topology

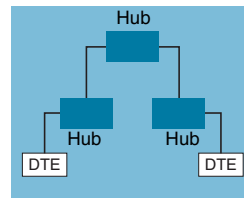

Tree topology

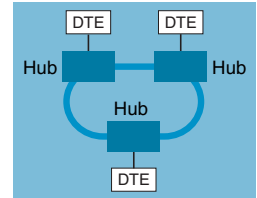

Ring topology  
(with 499 NOH 105 10)

### Characteristics and references

Transparent Ready.



Hubs						
<b>Interfaces</b>	Copper cable ports	Number and type	4 x 10BASE-T ports	4 x 100BASE-TX ports	3 x 10BASE-T ports	
		Shielded connectors	RJ45			
		Medium	Shielded twisted pair, CAT 5E category			
		Line length	100 m (328 ft)			
	Optical fiber ports	Number and type	–		2 x 10BASE-FL ports	
		Connectors	–		ST (BFOC)	
		Medium	–		Multimode optical fiber	
		Line length	–			
		50/125 µm fiber	–		2300 m (7.546 ft) (1)	
		62.2/125 µm fiber	–		3100 m (10.170 ft) (1)	
<b>Topology</b>	Number of cascaded hubs (copper)	Number of cascaded hubs (copper)	4 max.	2 max.	4 max.	
		Number of hubs in a ring (fiber)	–		11 max.	
		<b>Redundancy</b>	P1 and P2 redundant power supplies			
			P1 and P2 redundant power supplies, redundant optical ring			
<b>Power supply</b>	Voltage	~ 24 V (18...32 V), safety extra low voltage (SELV)				
	Power consumption	80 mA (130 max. at ~ 24 V)	210 mA (270 max. at ~ 24 V)	160 mA (350 max. at ~ 24 V)		
	Removable terminal	5-way				
<b>Operating temperature</b>		0...+ 60 °C (32...140 °F)				
<b>Relative humidity</b>		10...95% non condensing				
<b>Degree of protection</b>		IP 30	IP 20	IP 30		
<b>Dimensions W x H x D</b>	mm (in)	40 x 125 x 80 (1.57 x 4.92 x 3.14)	47 x 135 x 111 (3.15 x 5.51 x 3.35)	80 x 140 x 85 (1.85 x 5.31 x 4.37)		
		Weight	kg (lbs)	0.530 (1.17)	0.240 (0.53)	0.900 (1.98)
<b>Conformity to standards</b>		cUL 60950, UL 508 and CSA 142, UL 1604 and CSA 213 Class 1 Division 2, CE, GL				
<b>LED indicators</b>		Power, activity, link	Power, activity, link, error	Power, activity, link, collision		
<b>Alarm contact</b>		Power supply failure, permanent fault in hub, faulty link status of TP port (volt-free contact 1 A max. under ~ 24 V)				
<b>Reference</b>		499 NEH 104 10	499 NEH 141 00	499 NOH 105 10		

(1) Depends on the optical budget and fiber attenuation (typical specification: 2000 m (6.560 ft)).



#### Presentation

- The use of ConneXium transceivers makes it possible to perform the following:
- Creation of linear fiber optic bus topologies, for products with twisted pair cable Ethernet connection.
  - Interfacing products with twisted pair cable Ethernet connection with fiber optic cable.

Transceivers are “plug and play” devices that do not need any configuration. See “Cabling system” page 55.

ConneXium transceivers provide fiber optic connections for transmission in areas subject to interference (high levels of electromagnetic interference) and for long distance communications.

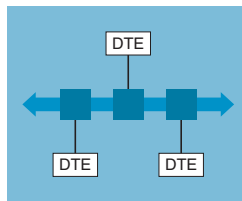

Linear topology on optical fiber

#### Characteristics and references

Transparent Ready



Transceivers					
<b>Interfaces</b>	Copper cable port	Number and type	1 x 10BASE-T port	1 x 100BASE-TX port	
		Shielded connectors	RJ45		
		Medium	Shielded twisted pair, CAT 5E category		
		Line length	100 m (328 ft)		
	Optical fiber ports	Number and type	1 x 10BASE-FL port	1 x 100BASE-FX port	
		Connectors	ST (BFOC)	SC	
		Medium	Multimode optical fiber		
		Line length			
		50/125 µm fiber	2300 m (7.546 ft) (1)	5000 m (16.404 ft) (1)	
		62.5/125 µm fiber	3100 m (10.170 ft) (1)	4000 m (13.123 ft) (1)	
Optical budget	50/125 µm fiber	10 dB	8 dB		
	62.5/125 µm fiber	13 dB	11 dB		
<b>Redundancy</b>		P1 and P2 redundant power supplies			
<b>Power supply</b>	Voltage	--- 24 V (18...32), safety extra low voltage (SELV)			
	Power consumption	80 mA (100 max. at --- 24 V)	190 mA (240 max. at --- 24 V)		
	Removable terminal	5-way			
<b>Operating temperature</b>		0...+ 60 °C (32...140 °F)			
<b>Relative humidity</b>		10...95% non condensing			
<b>Degree of protection</b>		IP 30	IP 20		
<b>Dimensions W x H x D</b>	mm (in)	40 x 134 x 80 (1.57 x 5.47 x 3.14)		47 x 135 x 111 (3.15 x 5.51 x 3.35)	
<b>Weight</b>	kg (lbs)	0.520 (1.15)		0.230 (0.50)	
<b>Conformity to standards</b>		cUL 60950, UL 508 and CSA 142, UL 1604 and CSA 213 Class 1 Division 2, C€, GL			
<b>LED indicators</b>		FM 3810, FM 3611 Class 1 Division 2		–	
<b>Alarm contact</b>		P1 and P2 power supplies, Ethernet link/port status			
		Power supply failure, permanent fault in hub, faulty link status of TP port (volt-free contact 1 A max. under --- 24 V)			
<b>Reference</b>		499 NTR 100 10	499 NTR 101 00		

(1) Depends on the optical budget and fiber attenuation (typical specification: 2000 m (6.560 ft)).

### Presentation

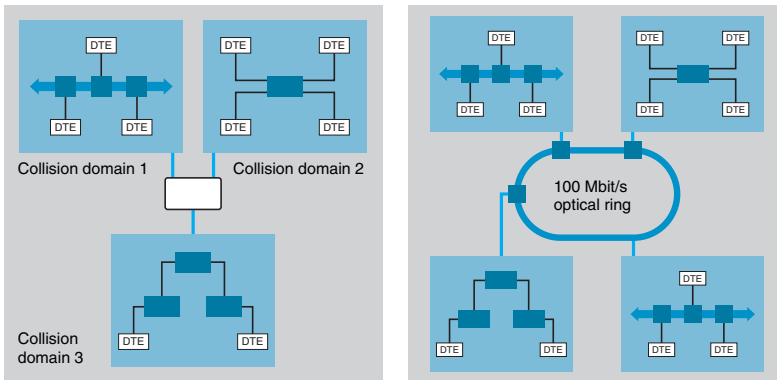

Switches (see “Cabling system” page 58) are used to increase the limits of architectures based on hubs or transceivers, by separating collision domains. Higher layer communication is provided between the ports, and collisions at link layer are not propagated (filtering). They therefore improve performance by better allocation of the pass band due to the reduction of collisions and the network load. Certain ConneXium switches also enable redundant architectures to be created on twisted pair copper or fiber optic ring. Switches are “plug & play” devices that do not need any configuration. They can also be administered remotely via the SNMP or HTTP protocols for monitoring and diagnostics purposes.

### Characteristics and references



Switches			Unmanaged basic	Shielded twisted pair and optical fiber, unmanaged				
Interfaces	Copper cable ports	Number and type	5 x 10BASE-T/ 100BASE-TX ports	4 x 10BASE-T/ 100BASE-TX ports	3 x 10BASE-T/ 100BASE-TX ports	4 x 10BASE-T/ 100BASE-TX ports	3 x 10BASE-T/ 100BASE-TX ports	
		Shielded connectors	RJ45					
		Medium	Shielded twisted pair, CAT 5E category					
		Max. distances	100 m (328 ft)					
	Optical fiber ports	Number and type	–	1 x 100BASE-FX port	2 x 100BASE-FX ports	1 x 100BASE-FX port	2 x 100BASE-FX ports	
		Connectors	–	SC				
		Medium	–	Multimode fiber			Monomode fiber	
		Fiber length	–	–				
		50/125 µm fiber	–	5000 m (16.404 ft) (1)				
		62.5/125 µm	–	4000 m (13.124 ft) (1)				
Optical budget	9/125 µm	–	–				32 500 m (106.627 ft) (2)	
	50/125 µm fiber	–	8 dB				–	
	62.5/125 µm	–	11 dB				–	
	9/125 µm	–	–				16 dB	
Topology	Number of switches	Cascaded	Any					
		Redundant in a ring	–					
Power supply redundancy		–	P1 and P2 redundant power supplies					
Power supply	Voltage	–	– 24 V (19.2...30 V)					
	Power consumption	100 mA (120 max.)	200 mA max.	240 mA max.	200 mA max.	240 mA max.		
	Removable terminals	3-way	5-way					
Operating temperature		0...+ 60°C (32...140 °F)						
Relative humidity		10...95% non condensing						
Degree of protection		IP 20						
Dimensions W x H x D		mm (in)	75.2 x 143 x 43 (2.96 x 5.63 x 1.69)	47 x 135 x 111 (3.15 x 5.51 x 3.35)				
Weight		kg (lbs)	0.190 (0.42)	0.330 (0.72)	0.335 (0.74)	0.330 (0.72)	0.335 (0.74)	
Conformity to standards		UL 508, CSA 1010, EN 61131-2, cUL 60950, UL 508 and CSA 142, UL 1604 and CSA 213 Class 1 Division 2, C, E, GL						
LED indicators		Power supply, ETH link status, 10/100 Mbps						
Alarm contact		–						
		Activity, power supply failure, permanent fault in switch, faulty link status of TP port (volt-free contact 1 A max. under – 24 V)						
Reference		499 NES 251 00	499 NMS 251 01	499 NMS 251 02	499 NSS 251 01	499 NSS 251 02		

(1) Depends on the optical budget and fiber attenuation (typical specification: 2 km).  
 (2) Depends on the optical budget and fiber attenuation (typical specification: 15 km).

#### Characteristics and references (continued)

Transparent Ready



Switches			Unmanaged, copper	Managed, copper	Managed, copper + fiber	
<b>Interfaces</b>	Copper cable ports	Number and type	8 x 10BASE-T/ 100BASE-TX ports	7 x 10BASE-T/ 100BASE-TX ports	5 x 10BASE-T/100BASE-TX ports	
		Shielded connectors	RJ45			
		Medium	Shielded twisted pair, CAT 5E category			
		Max. distances	100 m (328 ft)			
	Optical fiber ports	Number and type	–		2 x 100BASE-FX ports	
		Connectors	–		SC	
		Medium	–		Multimode optical fiber   Monomode optical fiber	
		Fiber length	50/125 µm	–		5000 m (16.404 ft) (1)   –
			62.2/125 µm	–		4000 m (13.123 ft) (1)   –
			9/125 µm	–		–   32 500 m (106.627 ft) (2)
Optical budget		50/125 µm	–		8 dB   –	
	62.2/125 µm	–		11 dB   –		
	9/125 µm	–		–   16 dB		
Ethernet services	–		FDR client, SNMP V3, SNTP, multicast filtering for optimization of the Global Data protocol, Web based configuration VLAN, IGMP Snooping, RSTP (Rapid Scanning Tree Protocol), Port priority, Flow control, Port security			
<b>Topology</b>	Number of switches	Cascaded	Any			
		Redundant in a ring	–	50 max.		
<b>Redundancy</b>	P1 and P2 redundant power supplies					
<b>Power supply</b>	Voltage	~ 24 V (18...32 V), safety extra low voltage (SELV)				
	Power consumption	125 mA (290 max.)		400 mA		
	Removable terminals	5-way				
<b>Operating temperature</b>	0...+ 60°C		0...+ 55°C			
<b>Relative humidity</b>	10...95% non condensing					
<b>Degree of protection</b>	IP 20					
<b>Dimensions W x H x D</b>	mm (in)	47 x 135 x 111 (3.15 x 5.51 x 3.35)		110 x 131 x 111 mm (4.33 x 5.16 x 4.37)		
		Weight		kg (lbs)		
<b>Weight</b>	0.230 (0.72)		0.460 (1.00)			
<b>Conformity to standards</b>	cUL 60950, UL 508 and CSA 142, UL 1604 and CSA 213 Class 1 Division 2, C€, GL					
<b>LED indicators</b>	P1 and P2 power supplies, Ethernet link status,		P1 and P2 power supplies, Ethernet link status, redundancy management			
<b>Alarm contact</b>	Power supply failure, permanent fault in hub, faulty link status of TP port (volt-free contact 1 A max. under ~ 24 V)					
	–		Redundancy health			
<b>Reference</b>	499 NES 181 00		499 NES 271 00	499 NOS 271 00	499 NSS 271 00	

(1) Depends on the optical fiber budget and fiber attenuation (typical specification: 2 km).

(2) Depends on the optical fiber budget and fiber attenuation (typical specification: 15 km).

## Characteristics and references



IP 67 switch		Unmanaged, copper	
<b>Interfaces</b>	Copper cable ports	Number and type	5 x 10BASE-T/ 100BASE-TX ports
		Shielded connectors	4-way M12 (type D, female)
		Medium	Shielded twisted pair, CAT 5E category
		Max. distances	100 m (328 ft)
	Optical fiber ports	Number and type	–
		Connectors	–
		Medium	–
Fiber length		–	
Ethernet services	Optical budget	–	
<b>Topology</b>	Number of switches	Cascaded	Any
		Redundant in a ring	–
<b>Redundancy</b>		–	
<b>Power supply</b>	Voltage		– 24 V (– 18...32 V), safety extra low voltage (SELV)
	Power consumption		100 mA
	Connector		5-way M12 (type A, male)
<b>Operating temperature</b>		0...+ 60°C	
<b>Relative humidity</b>		–	
<b>Degree of protection</b>		IP 67	
<b>Dimensions W x H x D</b>		mm (in)	60 x 126 x 31
<b>Weight</b>		kg (lbs)	0.210 (0.46)
<b>Conformity to standards</b>		cUL 508 and CSA 22.2 14	
<b>LED indicators</b>		Power supplies, link status, data activity	
<b>Alarm contact</b>		–	
<b>Reference</b>		TCS ESU 051 F0	

IP 67 cables						
<b>Ethernet cables</b>	Pre-equipped at both ends: 1 M12 connector (IP 67) and 1 RJ45 connector					
Length	1 m (3.3 ft)	3 m (9.8 ft)	5 m (16.4 ft)	10 m (32.8 ft)	25 m (82 ft)	40 m (131.2 ft)
<b>Reference ▲</b>	TCS ECL 1M3M 1S2	TCS ECL 1M3M 3S2	TCS ECL 1M3M 5S2	TCS ECL 1M3M 10S2	TCS ECL 1M3M 25S2	TCS ECL 1M3M 40S2
<b>Ethernet cables</b>	Pre-equipped at both ends: 2 M12 connectors (IP 67)					
Length	1 m (3.3 ft)	3 m (9.8 ft)	5 m (16.4 ft)	10 m (32.8 ft)	25 m (82 ft)	40 m (131.2 ft)
<b>Reference ▲</b>	TCS ECL 1M1M 1S2	TCS ECL 1M1M 3S2	TCS ECL 1M1M 5S2	TCS ECL 1M1M 10S2	TCS ECL 1M1M 25S2	TCS ECL 1M1M 40S2
<b>Power cables</b>	Female M12 straight connector		Female M12 elbow wed connector			
Length	2 m (6.6 ft)	5 m (16.4 ft)	2 m (6.6 ft)	5 m (16.4 ft)		
<b>Reference</b>	XZC P1164L2	XZC P1164L5	XZC P1264L2	XZC P1264L5		
<b>Spare power connectors</b>	Female M12 straight connector		Female M12 elbowed connector			
<b>Reference</b>	XZC C12 FDM 50B		XZC C12 FCM 50B			

▲ Available later

# Transparent Ready® Products

## Cabling system

### ConneXium shielded twisted pair and fiber optic cables



490 NT● 000 ●●



490 NOC 000 05



490 NOT 000 05



490 NOR 000 05

#### Presentation

ConneXium shielded connection cables are available in two versions to meet current standards and approvals:

- Standard EIA/TIA 568 shielded twisted pair cables: these cables conform to the:
  - EIA/TIA-568 standard, CAT 5E category,
  - IEC 11801/EN 50173 class D.
 Their fire behavior conforms to:
  - NFC 32070# class C2 and IEC 322/1,
  - Low Smoke Zero Halogen (LSZH).
- UL and CSA 22.1 approved shielded twisted pair cables. Their fire resistance conforms to NFPA 70.

#### References

##### Standard EIA/TIA 568 shielded twisted pair cables

Description	Pre-equipped at both ends	Length m (ft)	Reference	Weight kg
<b>Straight-through shielded twisted pair cables</b>	2 RJ45 connectors	2 (6.6)	490 NTW 000 02	—
	For connection to terminal devices (DTE)	5 (16.4)	490 NTW 000 05	—
		12 (39.4)	490 NTW 000 12	—
		40 (131.2)	490 NTW 000 40	—
		80 (262.5)	490 NTW 000 80	—
<b>Crossed cord shielded twisted pair cables</b>	2 RJ45 connectors	5 (16.4)	490 NTC 000 05	—
	For connections between hubs, switches and transceivers	15 (49.2)	490 NTC 000 15	—
		40 (131.2)	490 NTC 000 40	—
		80 (262.5)	490 NTC 000 80	—

##### UL and CSA 22.1 approved shielded twisted pair cables

Description	Pre-equipped at both ends	Length m (ft)	Reference	Weight kg
<b>Straight-through shielded twisted pair cables</b>	2 RJ45 connectors	2 (6.6)	490 NTW 000 02U	—
	For connection to terminal devices (DTE)	5 (16.4)	490 NTW 000 05U	—
		12 (39.4)	490 NTW 000 12U	—
		40 (131.2)	490 NTW 000 40U	—
		80 (262.5)	490 NTW 000 80U	—
<b>Crossed cord shielded twisted pair cables</b>	2 RJ45 connectors	5 (16.4)	490 NTC 000 05U	—
	For connections between hubs, switches and transceivers	15 (49.2)	490 NTC 000 15U	—
		40 (131.2)	490 NTC 000 40U	—
		80 (262.5)	490 NTC 000 80U	—

##### Fiber optic cables

Description	Pre-equipped at both ends	Length m (ft)	Reference	Weight kg
<b>Glass fiber optic cables for terminal devices (DTE) to hubs, switches and transceivers</b>	1 SC connector and 1 MT-RJ connector	5 (16.4)	490 NOC 000 05	—
	1 ST (BFOC) connector and 1 MT-RJ connector	3 (9.8)	490 NOR 000 03	—
		5 (16.4)	490 NOR 000 05	—
		15 (49.2)	490 NOR 000 15	—
		2 MT-RJ connectors	—	—

##### IP 67 cables

Description	Pre-equipped at both ends	Length m (ft)	Reference ▲	Weight kg
<b>Ethernet copper cables for IP 67 switch</b>	1 4-way M12 IP 67 connector 1 RJ45 connector	1 (3.3)	TCS ECL 1M3M 1S2	—
		3 (9.8)	TCS ECL 1M3M 3S2	—
		5 (16.4)	TCS ECL 1M3M 5S2	—
		10 (32.8)	TCS ECL 1M3M 10S2	—
		25 (82)	TCS ECL 1M3M 25S2	—
		40 (131.2)	TCS ECL 1M3M 40S2	—
	2 4-way M12 IP 67 connectors	1 (3.3)	TCS ECL 1M1M 1S2	—
		3 (9.8)	TCS ECL 1M1M 3S2	—
		5 (16.4)	TCS ECL 1M1M 5S2	—
		10 (32.8)	TCS ECL 1M1M 10S2	—
		25 (82)	TCS ECL 1M1M 25S2	—
		40 (131.2)	TCS ECL 1M1M 40S2	—

▲ Available later



# 9 - Modbus-IDA organization and Collaborative Automation Partner Program

## 9 - Presentations and partner data sheets

- Modbus™ IDA organization . . . . . page 127
- Presentation of Collaborative Automation Partner Program . . . . . page 128
- Transparent Ready Partners
  - Partner directory . . . . . page 129
  - ACKSYS . . . . . page 130
  - ACTL . . . . . page 131
  - Anyware Technologies . . . . . page 132
  - connectBlue . . . . . page 133
  - DATA-LINC Group . . . . . page 134
  - ErgoTechSystems Inc . . . . . page 135
  - FieldServer Technologies . . . . . page 136
  - Hirschmann Electronics . . . . . page 137
  - HMS Industrial Networks . . . . . page 138
  - Industrial Control Communications . . . . . page 139
  - Network Vision . . . . . page 140
  - Niobrara R & D . . . . . page 141
  - Phoenix Digital . . . . . page 142
  - ProSoft Technology . . . . . page 143
  - Senside . . . . . page 144
  - Webdyn . . . . . page 145



### Modbus-IDA

### Modbus-IDA presentation

#### Modbus-IDA organization mission statement

Modbus-IDA is a group of independent users and suppliers of automation devices that seeks to drive the adoption of the Modbus communication protocol suite and the evolution to address architectures for distributed automation systems across multiple market segments. Modbus-IDA will also provide the infrastructure to obtain and share information about the protocols, their application and certification to simplify implementation by users resulting in reduced costs (e.g. the specifications of the Modbus suite of protocols are available on line, free of charge).

#### Modbus-IDA Provides Visibility to Modbus and Modbus related Products

Modbus products are the solutions to Modbus users worldwide. Modbus-IDA helps users find suppliers through a visibility program that includes:

- Member listing on the Modbus-IDA.org website.
  - Product highlights in the Modbus newsletter and on the web.
- Join the discussion as Modbus-IDA embraces new technologies, and help guide the future of Modbus-IDA as part of the technical working groups. You can join on-line at [www.modbus-ida.org](http://www.modbus-ida.org)

#### Benefits for component suppliers, Integrators and Users

Your Membership in Modbus-IDA helps provide a myriad of open technology benefits to you and your employees. An extract of the benefits includes:

- Access to a rich library of shared users and implementers experiences.
- Participation in a dynamic resourceful User Forum.
- Access to a consultant referral directory that brings together users and experts.
- Newsletters and technical training programs.

#### Modbus protocol Conformance Testing Program

The true benefit of any open standard is the assurance it provides to users that the products they buy will interoperate seamlessly. Unfortunately, any specification, no matter how carefully written, is subject to interpretation and occasional misunderstanding. That's where conformance testing becomes valuable.

The Modbus Conformance Testing Program provides independent verification that a broad array of qualifications has been met in compliance with Modbus specifications. It provides end users with the comfort that their design and configuration process will proceed smoothly and assures suppliers that their products were developed in accordance with key Modbus criteria.

This program is administered by Modbus-IDA.org and is performed at independent service providers, the Modbus TCP/IP Conformance Test Laboratory are available in the United States of America and China. For more details, consult the Modbus-IDA website.

#### TCP/IP Modbus toolkit available through Modbus-IDA.org

The first edition of the **TCP/IP Modbus CD Toolkit V1.0** is a great collection of resources, selected to assist users and developers in implementing Ethernet TCP/IP Modbus servers or clients. This toolkit targets essential messaging services. Additional toolkits will be made available in the future to facilitate the deployment of other Transparent Ready services such as Global Data, etc.

This resources toolkit provides **Specifications, Implementation Guides, diagnostics, test tools** and **examples source code**. Also included the certification test suite as developed and used by the Modbus Certification Laboratory at the University of Michigan.

#### Become involved with the Modbus-IDA.org

Take advantages of the Modbus-IDA Website: [www.modbus-ida.org](http://www.modbus-ida.org)

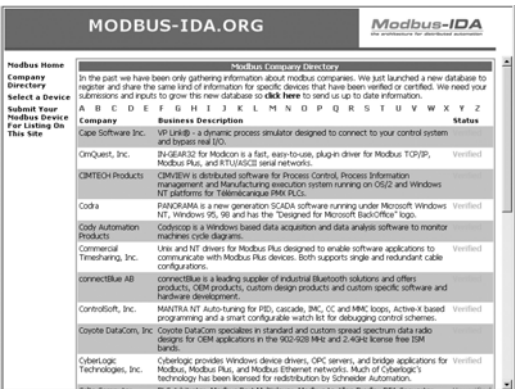
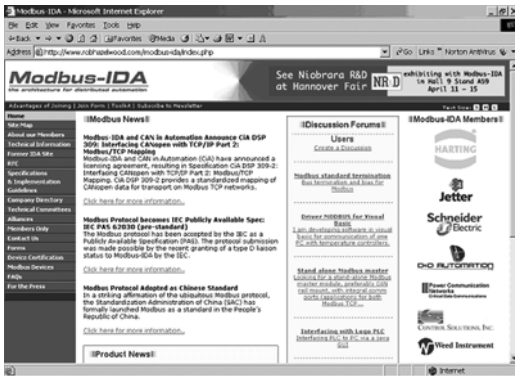



Collaborative Automation  
Partner Program



### Presentation of the partner program

#### Overview

The Collaborative Automation approach is a way of sharing data, interconnecting software tools, accessing information in real time at any point within an architecture... all with the aim of maximizing productivity.

The “Collaborative Automation Partner Program” is a program for sharing technology. Its aim is to follow a collaborative approach to promote partner products and solutions that complement the Telemecanique offer within the world of industrial control systems. The products promoted in this program use technologies developed either by our partner organizations, or by Telemecanique (Modbus Plus or Fip networks, Modicon Quantum or Modicon Premium PLCs, Unity interfaces to name but a few examples), or they use standard technologies (Ethernet Modbus TCP/IP, OPC, etc).

#### The program partners

There are currently more than 80 member organizations in the “Collaborative Automation Partner Program” offering more than 700 products in total. There are 3 categories of partner:

- Technology partners
- Unity partners
- Transparent Ready partners

The Transparent Ready partner offers are principally in the areas of wireless communication TCP/IP based, gateways, servers, modems, bridges and remote application solutions over the Internet.

#### Contacts

Find out more about the “Collaborative Automation Partner Program” at:

[www.collaborativeautomation-schneider-electric.com](http://www.collaborativeautomation-schneider-electric.com)

For any additional information, contact:

**Collaborative Automation Partner Program**

One High Street  
North Andover, MA 01845 USA

- Fax: +1 978 975 9321
- E-mail: [info.capp@us.schneider-electric.com](mailto:info.capp@us.schneider-electric.com)

More information on how to join the partner program can be found on the Collaborative Automation website:

[www.collaborativeautomation-schneider-electric.com](http://www.collaborativeautomation-schneider-electric.com)

Company Name	Type	Products	Contact
<b>A</b> <b>ACKSYS Communications &amp; Systems</b>	Wireless	See page 130	
<b>ACTL</b>	Gateway/server	See page 131	
<b>Anyware Technologies</b>	Web portal	See page 132	
<b>C</b> <b>connectBlue AB</b>	Wireless	See page 133	
<b>CyberLogic Technologies, Inc.</b>	Connectivity	Cyberlogic's MBX Driver provides connectivity between Modbus, Modbus Plus or Modbus TCP/IP host interface adapters and 32-bit applications using either Modicon's NETLIB interface specification or Cyberlogic's high performance MBXAPI.	<b>Kemal Turedi</b> 5480 Corporate Drive Suite 220 Troy, MI 48098 USA Tel. +1 248 631 2200 Fax +1 248 631 2221 <a href="mailto:kturedi@cyberlogictech.com">kturedi@cyberlogictech.com</a>
<b>D</b> <b>Data-linc Group</b>	Wireless	See page 134	
<b>Dymec</b>	Networking	Hardened Networking Products that deliver optical isolation of data and control devices, improved network and data reliability, and increased security for control & monitoring networks in harsh industrial environments. DYMEC-Hardened products are designed. SOAP/XML client/server interface (see pages 32 and 33). Recipe management. Web based HMI interface with actives pages support. By simply setting parameters, the FactoryCast HMI application development.	<b>Rick Sales</b> 25 Commerce Way # 1 North Andover, MA 0184 USA Tel. +1 978 688 8807 Fax +1 978 688 8771 <a href="mailto:rsales@dymec.com">rsales@dymec.com</a>
<b>E</b> <b>ErgoTech Systems Inc</b>	Web portal	See page 136	
<b>F</b> <b>FieldServer Technologies</b>	Gateway/router	See page 137	
<b>H</b> <b>Hirschmann GmbH &amp; Co</b>	Networking	See page 138	
<b>HMS Industrial Networks</b>	Gateway	See page 139	
<b>I</b> <b>Industrial Control Communications</b>	Gateway/router	See page 140	
<b>N</b> <b>Network Vision</b>	Network tool	See page 141	
<b>Niobrara R &amp; D.</b>	Gateway/converter	See page 142	
<b>O</b> <b>OnTime Networks AS</b>	Network diagnostic tool	Time synchronization switch with integral time server. The T208 further enhances industrial Ethernet networks by incorporating NTP/SNTP (Network Time Protocol/ Simple Network Tome Protocol) or the new IEEE1588 standard for network synchronization.	<b>Trond Grendar</b> Glads vei 20 Oslo 0489 Norway Tel. 47 22 09 03 03 Fax 47 22 09 03 10 <a href="mailto:trond@ontimenet.com">trond@ontimenet.com</a>
<b>P</b> <b>Phoenix Digital Corporation</b>	Networking	See page 143	
<b>ProSoft Technology</b>	Wireless	See page 144	
<b>S</b> <b>Senside</b>	Web portal	See page 146	
<b>Softing North America</b>	Gateway/converter	This gateway to connect FOUNDATION Fieldbus H1 devices to any system that supports Modbus TCP/IP. There are four H1 ports. The unit is configured via an embedded web server. The connected H1 devices are configured via a separate standard FOUNDATION Fieldbus.	<b>Ken Hoover</b> 102 State Street Newburyport MA 01950 USA Tel. +1 978-499-9650 Fax +1 978-499-9654 <a href="mailto:ken.hoover@softing.com">ken.hoover@softing.com</a>
<b>W</b> <b>Webdyn S.A.</b>	Gateway/converter & server	See page 147	
<b>Weed Instrument</b>	Networking	The R208 Managed Ring Switch is the ideal solution for redundant systems. The Fast Re-configuration of Networks Topology (FRNT) concept of Weed Instrument offers ultra fast ring re-configuration (30 ms) of the network topology and both fault contact and SN.	<b>Rick J. Pennavaria</b> P.O.Box 300 Round Rock, TX 78680-0300 USA Tel. +1 512-434-2844 Fax +1 512-434-2851 <a href="mailto:rpennavaria@weedinstrument.com">rpennavaria@weedinstrument.com</a>
<b>Westermo</b>	Gateway/router	The ED-20 is a compact industrial Ethernet router with all the necessary features for operation in harsh industrial Ethernet systems. It can be used in a number of different ways to provide remote connections to Industrial Ethernet networks.	<b>Calle De Bruin</b> 43 Stora Sundby SE-640 Sweden Tel. 46 16 428000 Fax 46 16 428001 <a href="mailto:calle.debruin@westermo.se">calle.debruin@westermo.se</a>



WL-COMETH



WL-COMETH, IP 65

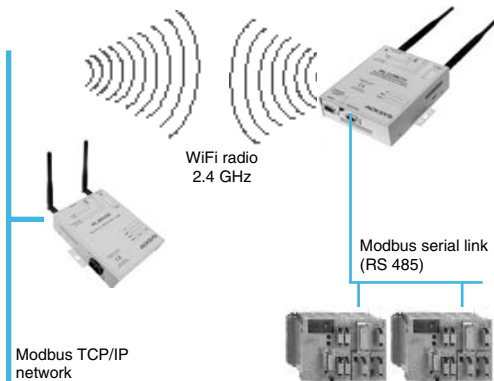

Serial Modbus to Modbus TCP/IP connection



WL-BRIDGE



WL-ACCESS

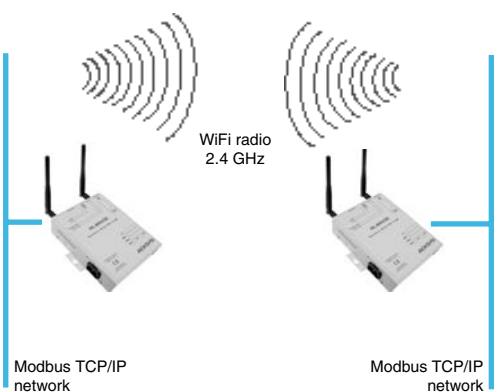

Modbus TCP/IP network interconnection

### ACKSYS wireless solutions

#### ACKSYS

ACKSYS is a French company specializing in telecommunication solutions for all industrial sectors where high performance, reliability and longevity are major requirements (industrial control systems, telecommunications, aviation, military, transport and health care).

#### Wireless solutions for industry (WiFi IEEE 802.11b)

ACKSYS also offers a range of wireless equipment based on the WiFi standard IEEE 802.11b. This range comprises an Ethernet/WiFi access point, an Ethernet/WiFi bridge and an RS 232, RS 422/RS 485 serial link server on Ethernet WiFi that also operates as a gateway between serial Modbus devices and the Modbus TCP/IP network.

These devices can be used to:

- Build a wireless Ethernet network infrastructure (WL-ACCESS devices and WL-BRIDGE devices).
- Connect two separate Ethernet networks without using any additional wiring (WL-BRIDGE).
- Connect serial link devices to the wireless Ethernet network.
- Connect an RTU serial Modbus device to a wireless Modbus TCP/IP Ethernet network (WL-COMETH device in gateway mode).
- Create a wireless connection between two serial link devices (WL-COMETH device in full duplex radio modem mode).

Unlike conventional, non-WiFi radio modems, which require same brand devices at both ends of the connection, WL-COMETH offers total interoperability of all devices conforming to standard IEEE 802.11b within the network, meaning that a single access point can communicate with more than 100 WL-COMETH devices. It is also possible to replace a wired full duplex serial link using two WL-COMETH radio devices.

IP65 weatherproof versions are also available for outdoor applications or applications in damp or dusty environments.

WL-COMETH is available in versions with 1, 2 and 4 RS 232, RS 422/RS 485 serial channels. All WL range devices have a built-in  $\sim$  85/264 V and  $\sim$  100/370 V or low voltage  $\sim$  9/36 V power supply.

They have universal mounting options (in enclosure, or wall or din rail mounting). Antennas are mounted on RSMA screw connectors allowing the use of high gain antennae for long distance applications.

### Contacts

Installing radio solutions requires specialist expertise. Please contact our partner:

Eric CARIQU  
**ACKSYS Communications & Systems**  
 ZA du Val Joyeux  
 10 rue des Entrepreneurs  
 Villepreux 78450, France

- Tel: +33 (0)1 30 56 46 46
- Fax: +33 (0)1 30 56 12 95
- E-mail: [eric.cariou@acksys.fr](mailto:eric.cariou@acksys.fr)
- Website: [www.acksys.fr](http://www.acksys.fr)



## eWON: Ethernet Gateway, Remote Access and eSCADA

### Presentation

eWON (*eYES Watching Over the Net*) is a family of products, ranging from an intelligent Ethernet gateway to a complete remote management solution for PLCs, devices and standalone equipment, with many embedded features, advanced services and tools.

Fully compatible with the whole range of Schneider PLCs, eWON is the ideal connectivity companion for your applications.

All eWON models are DIN rail mounted and are powered --- 12-24 V. They are equipped with a 10/100 Mbps Ethernet port and a RS 232/RS 485 serial port.

- Additional features:
- Full TCP/IP and PPP RFCs compliance
- Embedded web server, http, SMTP, DNS
- FTP client & server, SNMP (MIB II & Data)
- NTP (Network Time Protocol)
- Support for scripts programming (in Basic)
- ...

### eWON500: Modbus Programmable Gateway

Using internal memory tags, eWON publishes, in Modbus TCP/IP and/or in SNMP, data collected through numerous serial protocols, with advanced alarm capabilities. As the RS 232/RS 485 serial port can be accessed directly with scripts in BASIC, eWON decodes proprietary ASCII command sets and protocols of various devices (scalars, tracers, x-meters and more...) making them available to higher end systems such as ERP, MES, SCADA, Historian, etc...

### eWON2001 & eWON4001: PLC Remote Service & Management

Either point-to-point or through Internet, thanks to their optional embedded PSTN or GSM/GPRS modem, these eWON models offer efficient RAS service, enabling transparent operation from PL7 Pro, Concept or Unity, directly to the PLC programming port. Using advanced alarm management features, eWON will warn you of critical situations by mail, SMS or SNMP traps. With its data logging and reporting features, eWON 4001 will even send, at regular intervals or on alarms, by mail or by FTP, a complete production report or a graph with the latest trends.

### viewON: Design your own SCADA-like WEB pages, nice and easy!

Cutting short on delays and development costs, viewON enables everyone to create one's own HMI and production synoptics, on web pages, within minutes and without writing a single line of code. Thanks to its intuitive menus, animations and object libraries, viewON makes design of such complex pages easy and straightforward.

## Contacts

More information: [www.ewon.biz](http://www.ewon.biz)  
Worldwide distributors list: [www.ewon.biz/CtDistrib.htm](http://www.ewon.biz/CtDistrib.htm)

International Technical Support: [support@ewon.biz](mailto:support@ewon.biz)  
International Sales Information: [sales@ewon.biz](mailto:sales@ewon.biz)

**ACT'L sa**  
10A, avenue de l'artisanat  
B-1420 Braine L'Alleud, Belgium

- Tel: +32 2 387 27 82
- Fax: +32 2 384 47 16

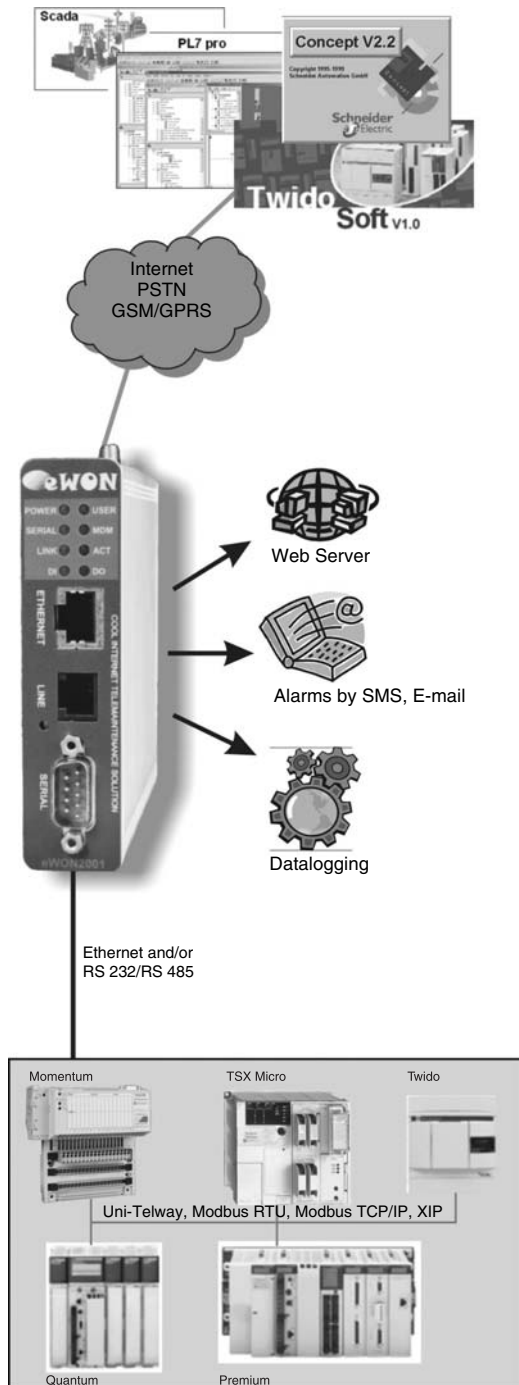

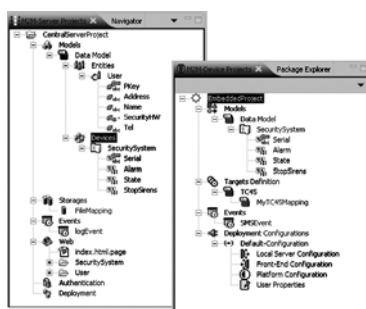
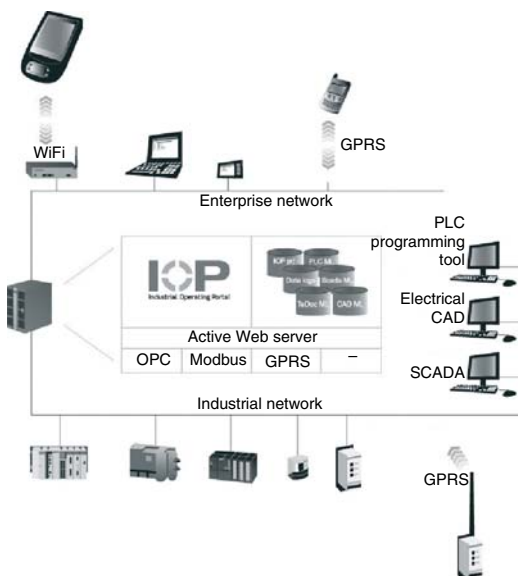

### Company Presentation

Anyware Technologies designs thin client software solutions, which aim at optimizing business performance. Recognized as an expert in the XML and Java world, she brings innovation up to meet customers needs and expectations.

Our current solutions are offered in the three business areas:

- Information Technology Systems
- Automation
- Machine to Machine (M2M)

### Automation products and solutions

#### IOP (Industrial Operating Portal)

A simple and efficient portal centralizing all your production system data and enabling a secure access from any media (mobile, PDA, computer...):

- A central and reliable control system
- Alerting you on any events, tracing them and recording the way they have been managed
- A powerful and easy-to-use diagnostic tool based on specialized viewers (PLC programs, electrical CAD, electrical devices and HMI)
- An online technical service manual which is easy to consult and update.

#### thin PLC (ex-PLC Animator)

**A simple and anywhere access to your animated PLC programs**

For a diagnostics even more efficient: thin PLC is the Industrial Operating Portal viewer dedicated to the diagnostics of automation functions.

thin PLC enables you to visualize and animate the automation applications in real time, with a simple web browser. Its user interface (programs, data, configuration parameters, operator screens) complies with the IEC 61131-3 standard. Equipped with connectors to your external tools (SCADA, control HMI etc.), it gives you a view of all your PLC programs in a secure environment.

With industrial products and solutions:

- Save time and money (deployment, diagnostics, repair, light training...)
- Get secure and multimedia access (computer, PDA, mobile...) to any component of the industrial fittings
- Capitalize on your technical knowledge with an interactive and upgrading technical manual.

### M2M products and solutions

**M2M Developer Suite:** A quick and easy software development environment to connect and manage your remote assets.

M2M Developer Suite is a powerful Graphical Development Environment enabling Machine To Machine applications to be developed, generated and deployed **much** faster than with any traditional development approach, thus minimizing your development costs and maximizing your productivity.

In the challenging world of Machine To Machine solutions, development tools can really make the difference...

### Contacts

**Anyware Technologies**

Prologue II  
Rue Ampère BP 87216  
31672 Labège Cedex

- Tel: +33 (0)5 61 00 52 90
- Fax: +33 (0)5 61 00 51 46
- Website: <http://www.anyware-technologies.com>





IP 22 version

IP 65 version



### Presentation connectBlue Wireless offer

#### Bluetooth Serial Port Adapter (RS 232, RS 422 or RS 485)

The Bluetooth Serial Port Adapter enables replacement of serial cables with Bluetooth wireless technology. Bluetooth is robust, proven and well suited for industrial applications and is license free to use.

The Serial Port Adapter connected to the RS 232/RS 422/RS 485 port of the industrial device acts like a wireless connection point to the device. A PC, laptop, PDA or any other serial device may connect wirelessly to the industrial device for ranges up to > 100 m. It supports both point-to-point and point-to-multipoint configurations.

The Serial Port Adapter is configured using a PC Configuration Wizard or by use of AT commands. The Serial Port Adapter is available in wall/DIN-rail mounted IP 22 or wall mounted IP 65.

#### Use Cases - Serial Port Adapter (RS 232, RS 422 or RS 485)

- 1 Operators, programmers etc. are provided wireless access to an industrial device for configuration, programming, diagnostics using a standard computer, laptop or PDA.
- 2 The Serial Port Adapter supports Wireless Multidrop. It is used to replace an RS 422/RS 485 multidrop network (running e.g. Modbus protocol) with Bluetooth.

### Contacts

Installing radio solutions requires specialist expertise. Please contact our partner:

## connectBlue

**connectBlue AB,**  
Norra Vallgatan 64  
Malmö, SE-21122, Sweden

- Tel: +46 (0)40 6307100
- Fax: +46 (0)40-237137
- E-mail: [sales@connectblue.se](mailto:sales@connectblue.se)
- Website: [www.connectblue.se](http://www.connectblue.se)



## License-free Wireless Solutions from Data-Linc Group

### DATA-LINC Group

Founded in 1988, Data-Linc Group has provided exceptionally reliable solutions for industrial automation systems including expert technical support and communications consultation. Data-Linc Group designs and manufactures high performance, superior quality modems that have been successfully implemented in all major industries including water/wastewater, oil and gas, automotive, consumer goods manufacturing/packaging, steel mills, mines, paper mills, utilities and transportation systems. Its products are available worldwide having recently expanded its market with a line of wireless modems for the European Union countries. Contact Data-Linc for information about their broad product line and their ability to interface seamlessly with Schneider equipment as well as a variety of manufacturers' PLCs and equipment in hybrid and legacy networks.

## Frequency Hopping Spread Spectrum Solutions

### Features

- License-free and wireless operates in the ISM (*Industrial/Scientific/Medical*) 900 MHz and 2.4 GHz bands
- Compact, flexible design with universal mounting, back panel or on optional DIN rail clip
- Rated range communication extended by Repeaters and/or high gain antennas
- Employs Smart Spectrum™ frequency hopping technology for exceptional data integrity and reliability-including high interference environments
- Wirelessly connects Ethernet PLCs and workstations
- Factory or field configured for your application ensuring trouble-free installation
- User configurable for Master, Remote, Repeater or Repeater/Remote mode
- Front panel LEDs: Power, RF Link, RF In, RF Out, LAN In, LAN Out, LAN Link, LAN Collision, Overrun Error
- Superior noise immunity, higher power output and better receiver sensitivity compared to other 2.4 GHz wireless systems
- SRM6310E-EU CE Mark and ETSI compliant for installation in EU countries



SRM6310E-EU, SRM6310E, SRM6210E  
Long Range Ethernet Radio Modems

## SRM6●10E License-free Wireless Ethernet Modems

Data-Linc Group's SRM6●10E Ethernet Radio Modems offer superior reliability, versatility and performance. The SRM6●10E modems are factory preconfigured for easy, trouble-free installation. Stated ranges for each of the modems may be extended with higher gain or directional antennas and multiples of this distance with repeaters.

It offers an unsurpassed rated range of:

- SRM6210E, 900 MHz ISM band: up to 40 km (*25 miles*) and an installed range of up to 56 km (*35 miles*) in optimal conditions with line-of-sight,
- SRM6310E, 2.4 GHz ISM Band: up to 16km (*10 miles*) with line-of-sight,
- SRM6310E-EU, 2.4 GHz ISM Band for European Union Countries (1): up to 8 km (*5 miles*) with unobstructed line-of-site, and an omni directional antenna.

(1) SRM6310E-EU is designed to meet CE European Mark and ETSI RF regulations. It combines advanced frequency hopping technology and a highly sensitive RF receiver to maximize transmission range and industrial performance.

## LincView™ OPC Enhanced Diagnostics Utility Software for SRM Network Management

### Features

- Simplifies monitoring and control of large, complex networks
- Offers OPC server capability
- Graphically displays view of entire wireless network
- Provides programmable warning/alarms with logging
- Displays both ends of all RF links
- Supports multiple radio networks
- Timestamps last communication
- Delivers historical graphing of key statistics and values
- Allows re-configuration of each network modem (RF link must first be present)

LincView OPC (*OLE for Process Control*), Data-Linc's enhanced diagnostics/management software, allows the monitoring and control of RF networks utilizing the SRM Family of wireless modems. LincView OPC provides the ability to troubleshoot and analyze the performance of RF links in large SCADA networks thus simplifying management of the network and the application together on one screen.

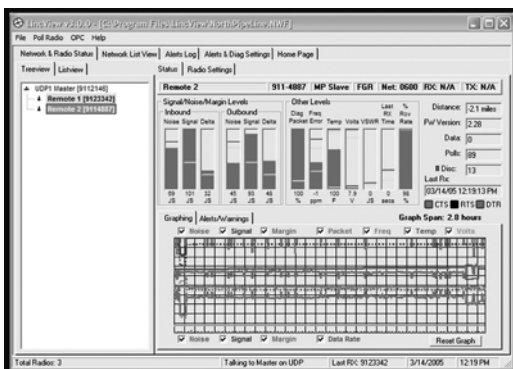

LincView OPC Enhanced Diagnostics Utility software



FastLinc FLC810E High Speed Wireless Ethernet 802.11b WiFi and IEEE compliant modem

### High Speed, Direct Sequence Spread Spectrum, WiFi Compliant Solutions

#### FastLinc™ FLC810E License-free 802.11b High Speed Ethernet Radio Modem

##### Features

- Provides fast, high-speed wireless Ethernet connectivity using the 2.412-2.462 GHz license-free spread spectrum band
- High output power and excellent receiver sensitivity for outstanding in-plant RF coverage and outdoor range
- Rated range of 8 km (5 miles) with unobstructed line-of-sight (multiples of this range using Repeaters)
- Coexists with Data-Linc's Smart Spectrum SRM6210E frequency hopping technology for hybrid 900 MHz and 2.4 GHz RF SCADA systems
- Wireless connections to PLCs, HMIs, Ethernet I/O systems and portable computers
- Compatible with WiFi and IEEE 802.11b compliant devices
- Functions as a wireless access point, a station adaptor and a bridge with repeating function
- Supports point-to-point, point-to-multipoint and peer-to-peer topologies
- Compact, flexible design with universal mounting including an optional DIN rail clip
- Web page (HTML) configuration and diagnostics
- Built-in data encryption and authentication for added security
- Factory or field configured for your application ensuring trouble-free installation
- AC or DC powered

FastLinc™ Industrial Ethernet Wireless Modems provide a high-speed, secure wireless solution using 2.4 GHz direct sequence technology with connectivity up to 11 Mbps (over the air data rate) at distances up to 8 km (5 miles) - multiples of this with distance with repeaters. FastLinc modems function as a wireless 802.11b access point, wireless bridge or remote repeater and supports point-to-point, point-to-multipoint and peer-to-peer topologies for IEEE 802.11b, WiFi compliant communications. Both Ethernet stand-alone and PCMCIA models are available.

#### FastLinc FLC800C License-free 802.11b High Speed Ethernet PCMCIA Card

##### Features

- Provides high-speed wireless Ethernet connectivity using the 2.412-2.462 GHz license-free spread spectrum band
- High output power (200 mW) and excellent receive sensitivity for exceptional range capability
- PCMCIA card fits within most laptop computers
- Compatible with WiFi and IEEE802.11b compliant devices
- Built-in data encryption and authentication for added security
- Includes site survey software



FastLinc FLC800C High Speed Wireless Ethernet 802.11b WiFi and IEEE compliant PCMCIA card

FastLinc™ Industrial Ethernet Wireless Modems are a high-speed, secure wireless solution. The FLC800C Industrial Wireless PCMCIA Card provides much higher output power than commercially available IEEE 802.11b cards. This greatly increases the range in challenging RF environments such as industrial plants. The FLC800C is ideal for portable computers used to access plant networks for HMI, SCADA, maintenance and PLC programming applications. When used in conjunction with the FLC810E modem, a robust wireless industrial network is created for outstanding coverage and high-speed performance. The FLC800C includes a software utility for simple configuration and reports RF performance information. The software provides an easy way to use a portable computer for RF site surveys. Also available in stand-alone Ethernet (FLC810E) models.

### Contacts

Installing radio solutions requires specialist expertise. Please contact our partner:

#### DATA-LINC Group

3535 Factoria Blvd.  
SE Bellevue, WA 98006, USA

- Tel: +1 425 882 2206
- Fax: +1 425 867 0865
- E-mail: [sales@data-linc.com](mailto:sales@data-linc.com)
- Website: [www.data-linc.com](http://www.data-linc.com)

Direct access to the DATA-LINC partnership with Schneider Electric, including applications examples: [www.data-linc.com/schneider/](http://www.data-linc.com/schneider/)





## Web based applications

### Ergo Tech Systems Inc.

ErgoTech was founded in 1994 as a developer of factory automation software. We shipped our first Java-based product in 1998, a suite of JavaBeans™ (Virtual Instrumentation Beans).

We are committed to providing quality products for factory automation based on open multi-platform technology. Our tool-chain and components are Java-based and rely on XML technology and other open standards.

We have several OEM relationships and welcome more. We also have distributors worldwide (Scandinavia, United Kingdom, U.S.A., and Benelux) and are seeking other qualified organizations to add value to or resell our products with added service.

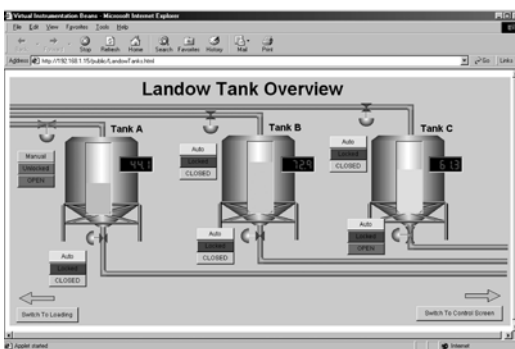

### ErgoVU

ErgoVU is a complete solution for data collection and visualization. It is ideal for Web-enabled HMI, SCADA, and operator panels. ErgoVU goes beyond simple HMI information displays -- it is also an application that collects data, alarms, and historical data 24/7. ErgoTech's easy-to-use screen builder (VIBLaces) lets you design SCADA-like screens from any computer workstation. Once complete, the screens are uploaded to the ErgoVU system and the "front-end" graphics can be viewed on the display of this system, or over the Web with any Web browser, while the "back-end" logic runs 24/7 on the ErgoVU system to deliver information to these views.

ErgoVU can be purchased as a turn-key software solution. It is installable on Windows NT/2000 or any other platform with a JVM, including Linux and other UNIX operating systems. On Windows platforms, ErgoVU can run concurrently with our OPC Gateway to provide information from third-party OPC Servers. ErgoVU is an integral part of ErgoTech's "Develop and Deploy" software package and is distributed with VIB and VIBLaces as part of this package.

ErgoVU, is a pure Java application and can run on many platforms of many sizes. We routinely deliver it to run on compact flash in industrial PC platforms using embedded Linux. This same hardware can support ErgoVU running on a full Linux installation on a hard drive with a database for historical logging capability. ErgoVU is packaged in our "Develop and Deploy" package with the OPC Gateway for Windows systems, either running stand-alone or in conjunction with other third-party SCADA or PC Control applications. We have OEMs licensing ErgoVU to run on Java-enabled operator stations, on some very small units with quarter-VGA LCD screens. Our Beans are now being converted for use on PDAs, Wireless Devices, Palms, etc. that run a minimal version of Java called "Micro Edition".

## Contacts

### ErgoTech Systems, Inc.

190 Central Park Square  
Los Alamos, NM 87544, USA

- Tel: +1 505.662.5156
- Fax: +1 775.254.3299
- U.S. Sales: +1 888.ERGOTECH
- E-mail: [info@ergotech.com](mailto:info@ergotech.com)



FS-B20 Series



FS-B30 Series



FS-B40 Series

## FieldServer Gateway

### FieldServer Technologies

The FieldServer Technologies gateway provides the link from multiple devices to Modbus TCP/IP (and other Modbus protocols including Modbus RTU, Modbus ASCII, and Modbus Plus). With over 85 different protocol drivers proven to interface to over 350 different devices, FieldServer is the leader in protocol gateways in the process control and building automation industries. The FieldServer driver library includes such common protocols as BACnet, LonWorks, Modbus TCP/IP and many proprietary networks, plus most legacy protocols for devices such as Caterpillar, Data Aire, McQuay, Carrier, and all major Fire Alarm Panels.

### FS-B20 Series

The FS-B20 Series is a serial to Ethernet gateway used to bring legacy devices utilizing a serial protocol to Modbus TCP/IP. This series has a serial port, LonWorks port and Ethernet and has the ability to handle up to 1000 points of information.

<http://www.fieldserver.com/products/gateways/FS-B2010.asp>

### FS-B30 Series

For applications requiring additional points or additional protocols the FS-B30 series meets the needs with 4 serial ports, LonWorks port and 2 Ethernet ports. In addition, Third party network ports are available. The multiple serial ports enable the user to bring in multiple serial devices and FieldServer software can combine that information into a common Modbus TCP/IP connection.

<http://www.fieldserver.com/products/gateways/FS-B3510.asp>

### FS-B40 Series

The FS-B40 Series has 10 serial ports, 2 Ethernet ports and a fieldbus port for such protocols as LonWorks, and others. The FS-B40 is ideal for plant wide applications requiring input from multiple serial and Ethernet devices to link to Modbus TCP/IP.

<http://www.fieldserver.com/products/gateways/FS-B4010.asp>

## Contacts

### FieldServer Technologies

1991 Tarob Court  
Milpitas, California 95035, USA

- Tel: 408-262-2299
- Toll Free: 888-509-1970
- Fax: 408-262-9042

### Sales Support:

- Tel: 408-262-2299 x125
- E-mail: [sales@fieldserver.com](mailto:sales@fieldserver.com)
- On-line: Complete our Sales Information Contact form



### Switches, Wireless AP's/AC's and Security Appliances

#### Hirschmann GmbH & Co

Hirschmann Electronics is a multi-national manufacturer of the broadest line of industrial networking products available today including transceivers, hubs, unmanaged and managed switches, network management software, and fiber interface products. Hirschmann was one of the early pioneers of Ethernet and now specializes exclusively in factory, process, and transportation automation applications.

Hirschmann Electronics is an innovator of industrial Ethernet products. This includes switches for Ethernet, Fast Ethernet, and Gigabit Ethernet. With advances in switching technology, Ethernet has become completely deterministic. Hirschmann managed switch capabilities include redundancy options, full duplex, port mirroring, IGMP Snooping for multicast filtering, and VLAN support for increasing network efficiency and security.

Hirschmann is a strategic Schneider Electric partner in the promotion and development of Industrial Ethernet.



#### LION 24 TP Workgroup Switch

Fast Ethernet switch with Flexible Gigabit uplink modules, the chassis is a fixed integrated component store and forward switching mode, Ethernet (10 Mbps), Fast Ethernet (100 Mbps), Gigabit Ethernet (1000 Mbps).

#### Characteristics

Management	SNMP v1, v2, v3, RMON 1, 2, 3 and 9, Web interface, Telnet, BootP
Diagnostics	LED's (power, link status, data error)
Configuration	TELNET, terminal SW, BOOTP, DHCP
Security	Radius, TACACS+, SSL, SSH, ACL, 802.1x port security
Other services	MDI/MDIX, 8k MAC addresses, cFlow control, HOL, Ports mirroring, IGMP w/Querier, Broadcast storm controls
Redundancy	Spanning and Rapid Spanning Tree, Link Aggregation
Max. data rate	8 Gbps, 5.9 million de packets per second



#### Eagle Security System

Ethernet Firewall or Firewall w/VPN. Devices capable of facilitating so-called bump-on-a wire firewall security as well as static routing or VPN Virtual Private Networks in 10/100 half/full duplex.

#### Characteristics

Management	Serial interface (CLI), HTTPS secure web interface or SNMP
Diagnostics	LEDs (power, link status, data, error, ACA), HiDiscovery, signaling contact
Configuration	Terminal SW, DHCP, Auto configuration adapter ACA, HiDiscovery and remote file and config storage
Other services	DHCP server, DHCP client, DynDNS and dial-in access via v.24 port
Filters	Via IP address, Subnets or Protocols
Operating Voltage	--- 24 V
Encryption Methods	DES-56, 3DES-128, AES-128, AES-192, AES-256
Authentication	PSK or pre-shared secret, X.509v3



#### BAT 11b Wireless AP/AC

Wireless Ethernet Access Point or Access Client. Devices in the wireless 802.11b range @ 11 Mbps with 2 10/100 half/full duplex Ethernet ports.

#### Characteristics

Management	Bat Discovery Protocol, Web Interface
Diagnostics	LEDs (power, link status, data, error), Bat Discovery
Configuration	DHCP, Bat Discovery
Encryption	None, WEP-64, 128, WEP plus, WPA
Antenna Connector	Dual RSMA antenna connectors for diversity
Operating Voltage	--- 24 V
Encryption Methods	Access Point (Infrastructure) Access Client (Ad-Hoc)
Authentication	160 m outdoors and 30 m Indoors



### Switches and routers

#### Mach 3001

Modular Gigabit switch with optional routing, the basic board is a fixed integrated component store and forward switching mode, Ethernet (10 Mbps), Fast Ethernet (100 Mbps), Gigabit Ethernet (1000 Mbps).

#### Characteristics

Management	Serial interface, web interface, SNMPv1, HiVision, automatic topology detection (IEEE 802.1ab)
Diagnostics	LEDs: Integrated power supply unit (PSU1), --- 24 V connections (PSU2, PSU3), integrated fans (FAN1 to FAN4), integrated basic board (BOOT/RUN, MASTER/SLAVE, ERROR), 4 simultaneous RMON groups at each port (statistics, history, alarms, events), port mirroring
Configuration	TELNET, terminal SW, BOOTP, DHCP, DHCP option 82, auto-configuration adapter (ACA 11), HiDiscovery
Security	SNMP security, port security, VLAN's 802.1Q
Other services	Prioritization (IEEE 802.1D/p), VLAN (802.1Q), multicast (IGMP snooping/Querier, GMRP), broadcast limiter, SNTP (Simple Network Time Protocol), flow control IEEE 802.3x
Protocols	protocols: RFC791(IP), RFC792 (ICMP), RFC793 (TCP/IP), RFC768 (UDP), RFC826 (ARP), RFC950 Internet standard subnetting procedure with the M-ROUTER module
Max. data rate	8 Gbps, 5.9 million packets per second



#### Mach 3002/3005

Modular Gigabit switch with optional routing, the basic board is a fixed integrated component store and forward switching mode, Ethernet (10 Mbps), Fast Ethernet (100 Mbps), Gigabit Ethernet (1000 Mbps).

#### Characteristics

Management	Serial interface, web interface, SNMPv1, HiVision, automatic topology detection (IEEE 802.1ab)
Diagnostics	LEDs: Integrated power supply unit (PSU1), --- 24 V connections (PSU2, PSU3), integrated fans (FAN1 to FAN4), integrated basic board (BOOT/RUN, MASTER/SLAVE, ERROR), 4 simultaneous RMON groups at each port (statistics, history, alarms, events), port mirroring
Configuration	TELNET, terminal SW, BOOTP, DHCP, DHCP option 82, auto-configuration adapter (ACA 11), HiDiscovery
Security	SNMP security, port security, VLAN's 802.1Q
Other services	Prioritization (IEEE 802.1D/p), VLAN (802.1Q), multicast (IGMP snooping/Querier, GMRP), broadcast limiter, SNTP (Simple Network Time Protocol), flow control IEEE 802.3x
Protocols	protocols: RFC791(IP), RFC792 (ICMP), RFC793 (TCP/IP), RFC768 (UDP), RFC826 (ARP), RFC950 Internet standard subnetting procedure with the M-ROUTER module
Max. data rate	8 Gbps, 5.9 million packets per second



### Contacts

#### Hirschmann Automation and Control GmbH

Stuttgarter Strasse 45-51  
72654 Neckartenzlingen  
Germany

- Tel: +49(0)7127/14-0
- Fax: +49(0)7127/14-1214
- Website: [www.hirschmann.com](http://www.hirschmann.com)

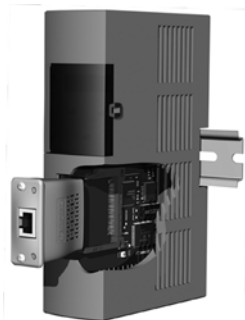

Embedded Anybus CompactCom for Ethernet/Modbus TCP/IP



Anybus Communicator - serial to network gateway



Anybus-X - network to network gateway

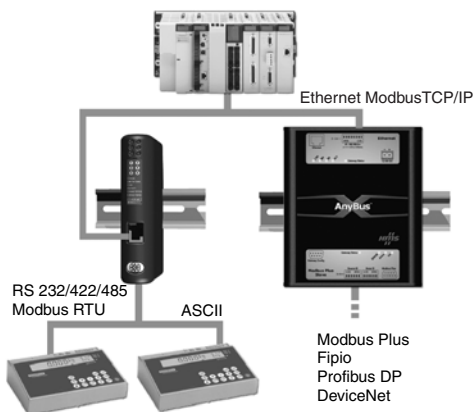

Gateway integration to Ethernet Modbus TCP/IP

### HMS Industrial Networks

#### Company and product overview

HMS Industrial Networks is a world leader in industrial networking, Industrial Ethernet and Fieldbus Communication, supplying products to the global world of automation. The Anybus range of products from HMS is today the world's most used third party product for industrial network connectivity.

Anybus products help OEM's, integrators and end-users to connect their products to all major industrial networks, such as Ethernet Modbus TCP/IP, Modbus Plus, Fipio, Profibus DP, DeviceNet, EtherNet/IP, Profinet, Modbus RTU, CC-Link, ControlNet and CANopen. Anybus products are available as intelligent embedded modules, external networking gateways as well as PCI interfaces.

#### Embedded Anybus technology for OEM manufacturers

Anybus-S and Anybus-M  
One single integration project of the embedded interfaces from HMS gives customers a complete coverage of all major Fieldbus and Industrial Ethernet networks. The proven credit-card-sized Anybus-S slave interfaces and Anybus-M master interfaces support 15 different networks, allowing customers to focus on their core competence, using Anybus technology to connect their products to networks.

Anybus CompactCom – the new generation of embedded interfaces  
The module-based range of embedded boards Anybus CompactCom takes embedded communication one step further. There is one separate low-priced Anybus CompactCom-module for each major industrial network, all of them featuring the size of half a credit-card.

Anybus CompactCom reflects the needs of modern industrial communication, allowing for tight integration to the host application. The integration procedure is very straight-forward - the customer only needs to add a simple Compact Flash connector to the host board, which will only add a minimum of cost to the design. The Anybus CompactCom modules are interfaced through the use of the Anybus CompactCom driver, which is available inside the Anybus CompactCom Starter kit. The starter kit also contains a series of modules and an adapter, enabling a development environment connected to a standard PC.

#### Powerful network integration through Anybus Gateways

Anybus Communicator connects products with serial interfaces to all major fieldbus and Industrial Ethernet networks. There is one separate version of Anybus Communicator for each major industrial network, such as Ethernet Modbus TCP/IP, Fipio, Modbus RTU, Modbus Plus, Profibus DP and DeviceNet. On the serial side, it is as default configured as a fully implemented Modbus RTU Master, which is designed to communicate with a sub-net with one or several Modbus RTU slave devices. It can be configured to support also other serial protocols as well as simple ASCII-communication. The PC-based ABC Config Tool allows an easy step-by-step configuration of the communication between devices on the serial subnet and the PLC master on the other side of the Anybus Communicator. The configuration can be saved to be re-used in future integration projects.

The Anybus-X Gateway family includes over 150 different versions which connect almost every possible combination of two industrial networks allowing for instant and powerful integration. Anybus-X supports integration to and from 15 different fieldbus networks, such as Ethernet Modbus TCP/IP, Modbus Plus, Profibus DP, DeviceNet, CANopen and CC-Link. Equipped with aluminum housing, the Anybus-X is designed to withstand harsh industrial environments, helping system integrators to easily interconnect between different networks, ensuring a transparent information flow throughout the entire plant.

The network architecture to the left shows Anybus Communicator and Anybus-X connected to the same PLC on Ethernet TCP/IP. In this scenario, Anybus Communicator integrates Modbus RTU slave devices and Anybus-X links the Ethernet Modbus TCP/IP network to any other industrial network.

### Contacts

**HMS Industrial Networks**  
Pilefeltsgatan 93-95,  
S-30250 Halmstad, Sweden,

- Tel: +46 35 17 29 00
- Fax: +46 35 17 29 09
- E-mail: [sales@hms.se](mailto:sales@hms.se)
- Website: [www.Anybus.com](http://www.Anybus.com)

#### Industrial Ethernet Gateways

##### ETH-200 Multiprotocol Network Gateway

The ETH-200 Ethernet Multiprotocol Network Gateway allows information to be transferred seamlessly between many different fieldbus networks with minimal configuration requirements. The ETH-200 provides:

- A 10BASE-T/100BASE-TX Ethernet port,
- Two RS 485 ports,
- One RS 232 port,
- Three common serial ports for direct connectivity to Toshiba 7-series, 9-series, 11-series or VF-nC1 Adjustable Speed Drives (ASDs).

These various communication ports operate independently, and are configurable along with the unit's internal point database via a standard web browser.

The ETH-200 currently provides support for the following protocols, with others under development:

- Modbus TCP/IP (slave)
- Ethernet/IP (server)
- Modbus RTU (RS 485 master & slave)
- Modbus RTU (RS 232 master & slave)
- Johnson Controls, Inc. Metasys N2 (RS 485 slave)
- Sullair Supervisor network (RS 485 master)
- Toshiba ASD (common serial master)
- Toshiba 3-series ASD (RS 232 master)
- Mitsubishi ASD (RS 485 master).

Don't see a protocol that you need?

Give us a call: we're always willing to investigate the implementation of additional open or customer-specific drivers.

The ETH-200 is a member of the ICC Network Gateway Series product family. Members of this family are designed to provide a uniform interface, configuration and application experience. This commonality reduces the user's learning curve, reducing commissioning time while simplifying support. The ETH-200 provides simultaneous support for many different communication protocols, allowing complex interchanges of data between otherwise incompatible networks.

The heart of the Network Gateway Series concept is an element called the "point database". The point database is entirely user-configurable, and provides the mapping information that allows requests from the various supported networks to be interpreted and stored in a common format. This allows data to be routed from any supported network to any other supported network.

Additionally, the point database provides the added benefit of "data mirroring", whereby current copies of point values (populated by a "source port" designation) are maintained locally within the gateway itself. This greatly reduces the request-to-response latency times on the various networks, as requests (read or write) can be entirely serviced locally, thereby eliminating the time required to execute a secondary transaction on a different network.

When properly configured, the gateway will become essentially "transparent" on the networks, and the various network devices can engage in a seamless dialog with each other.

#### Contacts

##### Industrial Control Communications, Inc.

2204 Timberloch Place, Ste. 250  
The Woodlands, TX 77380, USA

- Tel: +1 281 292 0555
- Fax: +1 281 292 0564
- E-mail: [sales@iccdesigns.com](mailto:sales@iccdesigns.com)
- Website: [www.iccdesigns.com](http://www.iccdesigns.com)





#### Network Vision Inc.

Network Vision Inc. was founded by a group of professionals who were eager to bring their ideas about industrial Ethernet to the automation industry - an industry that requires constant innovation and process improvement.

Unencumbered by corporate bureaucracies, and possessing extensive technical and marketing experience allows the company to be agile and responsive to the evolving markets.

Network Vision's goal from the start has been to design software for the plant floor that is easy to use and can effectively handle factory floor applications. With the kind of global growth that is expected for industrial Ethernet applications, Network Vision is a strong proponent of support tools require for successful deployment and continual operation. Network Vision's flagship software, called IntraVUE™, provides a powerful, yet easy to use, network and device visualization tool to the automation industry. The software is also adaptable to multiple applications in which the network availability is important.

#### IntraVUE

IntraVUE is a software package that provides true automatic network mapping and real-time monitoring function. Utilizing Ping, SNMP information and advanced algorithms, IntraVUE™ automatically draws an accurate connection diagram of the network. The software is installed on a computer that resides on the network and is running continuously. IntraVUE displays are viewed through a browser interface, thus allowing several people to view the real-time availability of the network on their own computer, or any computer accessing the webserver of the IntraVUE computer. Using a patented Hyperbolic representation, the entire network is displayed on a single screen.

IntraVUE is often applied in a network that may be a distance from the individuals responsible for supporting it. It may be in different facilities, remote pumping stations, electrical substations, or plants that are in other countries. The use of a browser to access IntraVUE provides you with capabilities as if you were local to the network.

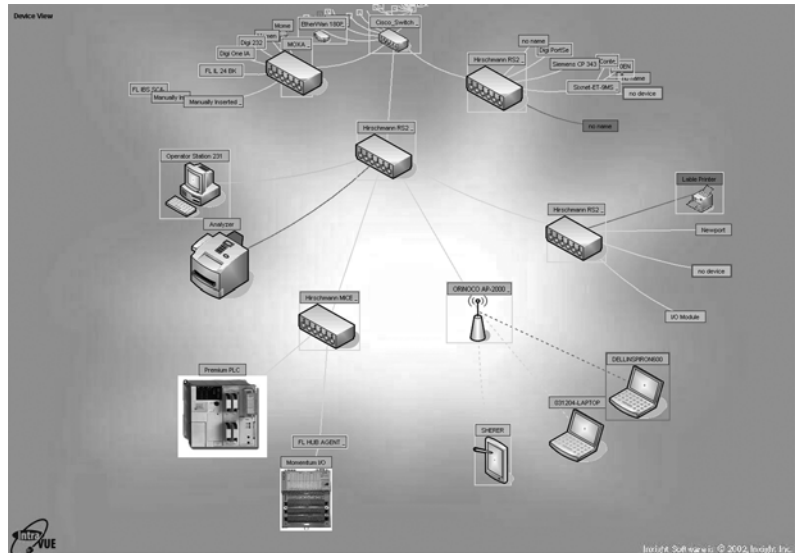

#### Contacts

**Network Vision, Inc.**  
 44 Merrimac Street  
 Newburyport, MA 01950, USA

- Tel: +1 978 499 7800
- Toll Free (US): 877 499 8100
- Fax: +1 978 4997860
- E-mail: [help@intravue.net](mailto:help@intravue.net)

# Transparent Ready® Products

## Collaborative Automation Partner Program

### Niobrara Research & Development Corporation



QUCM-OE



CNOE-211



CUCM-OE



PEN-T



MEB-RT



EPE5-T

### Gateways, bridges and protocol converters

#### Niobrara R&D Corporation

Niobrara is a U.S. company specializing in industrial data communication products for many of Schneider Electric's product lines. Our products are sold exclusively through the Schneider Electric channels worldwide.

#### Quantum-compatible Transparent Ready products

Niobrara's **QUCM-OE** is a bridge, router, protocol converter and data concentrator in Schneider's Quantum form factor. It has a 10BASE-T Ethernet port and two switch-selectable RS 232/RS 485 ports. The QUCM supports a long list of protocols and can appear to the Quantum processor as either I/O or an option module. For serial and Ethernet protocols not listed below, the QUCM is also a user-programmed module. The user can develop his own programs or, for a very reasonable price, Niobrara can write QUCM code to incorporate your devices into the Transparent Ready architecture.

#### Compact-compatible Transparent Ready products

Niobrara makes several Ethernet modules for the Compact line. Each has a 10BASE-T Ethernet port. All are Schneider Electric Collaborative Automation Partner Program (CAPP) products and all are e marked:

- The **CNOE-211** is an Ethernet option module for the newer Compact processors. It has capabilities very similar to the original Quantum NOE-211.
- The **CUCM-OE** is a bridge, router, protocol converter and data concentrator in Schneider's Compact form factor. It has a 10BASE-T Ethernet port and two switch-selectable RS 232/RS 485 ports. The CUCM supports a long list of protocols and can appear to the Compact processor as either I/O or an option module.

*Nota : For serial and Ethernet protocols not listed below, the CUCM is also a user-programmable module. The user can develop his own programs or, for a very reasonable price, Niobrara can write CUCM code to incorporate your devices into the Transparent Ready architecture.*

#### PowerLogic compatible Transparent Ready products

Niobrara was the first to make PowerLogic devices Transparent Ready. Niobrara's present offering, the **PEN-T**, has a 10BASE-T Ethernet port and can support up to 32 PowerLogic meters and Modbus devices on its 4-wire RS 485 port. It will attach to the back of a 2000-series circuit monitor or can be used stand-alone (P/N PEN-T-SA).

#### SY/MAX compatible Transparent Ready products

Niobrara manufactures an array of communication products for Square D's SY/MAX PLC line. Two of these products are Transparent Ready:

- The **MEB-RT** allows Transparent Ready access to Modbus Plus devices and SY/MAX Ethernet devices as well as a host of serial devices. It has a redundant-cable Modbus Plus port, a 10BASE-T Ethernet port and two RS 485 serial ports.
- The **EPE5-T** is an Ethernet port expander in the SY/MAX form factor. It allows SY/MAX, PowerLogic and other devices to be used in the Transparent Ready architecture. It can also bridge between Modbus TCP/IP and SY/MAX Ethernet.

#### Niobrara Supported Protocols

- Modbus RTU Master	- Modbus TCP/IP	- DNP 3.0
- Modbus RTU Slave	- HTTP	- RNIM
- Modbus ASCII Master	- FTP	- PNIM
- Modbus ASCII Slave	- SNMP	- Plogic
- Jbus Master	- SY/MAX Ethernet	- IDEC
- Jbus Slave	- INTERBUS	- SEAbus
- SY/MAX point-to-point	- LonWorks	- SEAbus +
- SY/MAX net-to-net	- Seriplex	- Gateway
- Dual Slave Modbus & SY/MAX	- Metasys	- Multidrop
- Dual Master Modbus RTU & RNIM	- Johnson P2	- Peripheral
- Modbus Plus	- Landis P1	- Transparent
	- INCOM	- Share
	- ASCII	- DF1

#### Contacts

Kenton Foster  
**Niobrara R&D Corporation**  
 P.O. Box 3418  
 Joplin, MO 64803-3418, USA

□ Tel: +1 417 624 8918  
 □ Fax: +1 417 624 8920  
 □ E-mail: [kfoster@niobrara.com](mailto:kfoster@niobrara.com)  
 □ Website: [www.niobrara.com](http://www.niobrara.com)





## Networking

### Phoenix Digital Corporation

Phoenix Digital fiber optic communication modules and cable provide complete Physical Layer Network Solutions for both Open Standard Networks and the Communication/Control Networks of every major Control System Supplier in the World.

Phoenix Digital offers Fiber Optic Modules and Cable for Programmable Controllers (PLCs) and Distributed Control Systems (DCS). Our products provide fiber optic communication solution, including fault tolerant, self-healing, very long distances, and network-topology independent (daisy-chain, star, point-to-point) critical features.

### DIN-Rail panel mount standalone modules

Fiber optic modules provide optical communication media, transparent to the communication protocol and configurable for distribution by the user in: ring, bus, star, tree, Helix or point-to-point network installations.

It also provides a continuous error checking for jitter, pulse width distortion, carrier symmetry, and optical signal strength. All of this, together with comprehensive self-test diagnostics, optimizes the overall integrity of Ethernet, Modbus, Modbus Plus, and Modicon Quantum Remote I/O (RIO) communication networks at-large, providing high reliable data communications for control and automation networking.

### Characteristics

- 10/100 Mbps Ethernet, Modbus Plus, Remote I/O, Modbus, Modbus TCP/IP, RS 232/RS 485
- Fault Tolerant, self-healing communications with 1 ms recovery time
- Phoenix Digital's proprietary Queuing System (PQS) to improve the network performance insuring even faster throughput for user identified network nodes
- Unlimited modules for complex multi-drop networks
- Real-time diagnostics
- Auto-negotiation, auto-crossover
- 850/1300 nm multimode, 1300/1550 nm monomode FX, ST, SC, MTRJ, and LC fiber optic connectivity, and up to 90 km inter-modular distance
- Available with single or dual power supply system for ~ 120/240 V, ~ 125 V, and ~ 24 V
- UL Class I, Division 2 Rating

## Contacts

### Phoenix Digital Corporation

7650 E. Evans Rd.  
Building A  
Scottsdale, AZ 85260, USA

- Tel: +1 480 483-7393
- Fax: +1 480 483-7391
- E-mail: [phxdigital@aol.com](mailto:phxdigital@aol.com)

# Transparent Ready® Products

## Collaborative Automation Partner Program

### ProSoft Technology



ProSoft Technology, Inc. was formally incorporated in 1990. By 1993 ProSoft had developed an extensive protocol library which helped them evolve from a single product company to a multiple product provider. Since then, ProSoft has become a major supplier of communication products for the industrial automation industry. ProSoft Technology has an extremely active product development program and customer recognition of their product quality. ProSoft serves the automation industry's communications and specialized applications needs with high quality products, application expertise, and technical support. Sales, application engineering, and support services are provided internationally by over 450 exclusive distributors served by their Regional Area Offices located in:

- North America: Seven regional area managers provide coverage for our distributors across the continent
- Latin America: Two full service offices; one servicing Brazil exclusively, and the other provides coverage to South America
- Europe: One full service office based in France serves Europe, Middle-East and Africa
- Asia Pacific: Offices in India and Malaysia servicing Asia, India, Australia and New Zealand



RLX-FH



RLX-IH

### Wireless Communication

#### 2.4 GHz Frequency Hopping Spread Spectrum

- Secure wireless communications with data encryption, proprietary radio protocol, and 2.4 GHz FHSS physical layer
- Dual antennas for maximum performance and networking flexibility
- Up to 25 km (16 miles) range with high-gain antennas (longer with repeaters)
- Remote diagnostics
- User-programmable over the air (after initial configuration) with easy-to-use Windows-based software
- Up to 1000 addressed devices with 2000 radios and 78 repeaters per network
- 32 user-selectable data channels for multiple network operation
- Uses a proprietary RF protocol and 158 unique hopping patterns to prevent unwarranted interception of RadioLinX data transmission
- Class 1 Div 2 rated for hazardous locations
- Modems available include: Serial (RLX-FHS), Ethernet (RLX-FHE) and Ethernet with Serial Server (RLX-FHES)

#### RadioLinX Industrial Hotspot (IEEE 802.11b)

The RadioLinX Industrial Hotspot (RLX-IH) is an ultra-fast wireless solution for the most demanding industrial applications. While providing the benefits of industrial wireless Ethernet connectivity for fixed or mobile devices with 10BASE-T/100BASE-TX Ethernet connections, the RLX-IH acts as a repeater and an industrial hotspot for other wireless client devices:

- Four times more powerful than high-speed commercial grade radios, RLX-IH allows better coverage of the factory floor with fewer radios and outdoor links of 32 km (20 miles) (subject to country regulations)
- Single unit repeater functionality; no more stringing Ethernet cable between wireless access points
- Attach an Ethernet device directly to the RLX-IH
- Powerful transmitter with amplifier option for long range outdoors and superior coverage with fewer radios indoors
- Security you can trust with strong TKIP encryption, 802.1X and MAC ID authentication

### ProTalk Q in-rack interface modules

#### Protocol Interfaces for Modicon Quantum/Unity

The ProTalk Q communication modules are Quantum/Unity backplane compatible allowing Quantum processors to easily interface with alternate networks:

- Single Slot: Quantum backplane compatible
- Recognized as an Options module and has access to PLC memory for data transfer
- Simple text configuration file is used to setup and define the module's operation

#### ProTalk Q applications include

- 'C' programmable
- DF1
- DNP 3.0
- DNP 3.0 over Ethernet
- HART Multi-drop
- Flow computer
- Ethernet/IP
- IEC 60870-5-101 Slave
- IEC 60870-5-103 Master
- IEC 60870-5-104 Server
- Profibus DP



Original ProLinX (4000 Series)



ProLinX Plus (5000 Series)

### ProLinX Communication Gateways

#### Stand-alone, DIN-rail mounted gateways

ProLinX Communication Gateways provide protocol connectivity between two networks with over 150 connectivity options. These stand-alone, DIN-rail mounted, industrial gateways are available in two form factors:

- The original ProLinX
- The new ProLinX Plus extruded aluminum enclosure

ProLinX Plus offers the same connectivity options as in the original gateways and include optional H or G mount capabilities.

#### Protocol combinations include

- Modbus TCP/IP to DF1
- Modbus TCP/IP to Modbus
- Modbus TCP/IP to DNP Slave
- Modbus TCP/IP to DNP Master
- Modbus TCP/IP to IEC 60870-5-101 Slave
- Modbus TCP/IP to IEC 60870-5-103 Master
- Modbus TCP/IP to IEC 60870-5-104 Server
- Modbus TCP/IP to ASCII
- Modbus TCP/IP to DH-485
- Modbus TCP/IP to Modbus Plus
- Modbus TCP/IP to PROFIBUS DP Slave
- Modbus TCP/IP to PROFIBUS DP Master
- Modbus TCP/IP to Remote I/O
- Modbus TCP/IP to EtherNet/IP
- Modbus TCP/IP to DNP over Ethernet
- Modbus TCP/IP to HART Multi-drop
- Modbus TCP/IP to Honeywell DE

### Contacts

For Quantum/Unity interfaces, wireless communication or stand-alone gateways please contact our partner:

**ProSoft Technology, Inc.**

- Asia Pacific: +603 7724 2080
- Europe: +33(0)5 34 36 87 20
- Latin America: +1 281 298 9109
- North America: +1 661 716 5100
- E-mail: [prosoft@prosoft-technology.com](mailto:prosoft@prosoft-technology.com)
- Website: [www.prosoft-technology.com](http://www.prosoft-technology.com)

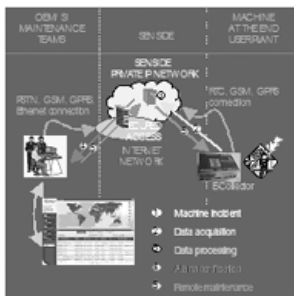

The installed base Global view



The Alarm view

### Senside Presentation

Senside offers solutions that are innovative and complete for remote access and management of machines' installed base, to machines builders and system integrators. Senside solution enables optimization of after-sales service for machine builders or integrators and the development of value added services for machines and systems users.

Senside is a subsidiary of **Schneider Electric** (80%), in partnership with **France Telecom**: this alliance brings together, within Senside, a unique expertise in industrial automation and telecommunications.

### Senside Pack, the principles

#### A turnkey solution:

- Simple to set up and easy to use, reliable and secured.
- Available worldwide through the Equant (France Telecom) private IP network (140 countries).

#### A multi-protocol solution:

- Available on the whole Telemecanique PLC (Twido, Micro, Premium, Momentum, Quantum) and drives (Altivar) product families.
- Compatible as well with MPI, DF-1, Ethernet protocols.

#### A complete solution, provided on the basis of a yearly subscription including:

- e-Collecto (server connected to the machine control system, shipped with cabling and installation guide).
- Machines access portal, operated by Senside and accessible via Internet.
- Private IP network ensuring a reliable and secure connection to the machines (via a standard local telephone line).
- Training, maintenance and support.

### Senside pack, detailed features

#### Remote access to machines or Installations:

- Remote viewing and/or modification of machine control device programmes.
- Remote control of SCADA PCs.
- Remote access to local Web servers.

#### Web Portal:

- Global view of the machine installed base and its status.
- Automatic set up of the remote connection to a given machine.

#### Access rights management:

- Users authentication via Personal Login/password.
- Users profiles management: machine perimeter (geographic criteria, machine user name, machine model...) and applications features (consultation, programming...).

#### Remote access security:

- No access to the Machine telephone line from outside Senside network.
- Physical key provided to the machine local operator for locking/unlocking access to the control programmable devices.

#### Monitoring of status and variables:

- Definition by the customer of the status or variables to be monitored.
- Alarm notification sent by SMS, FAX or E-mail in case of drift (modification on the portal of alarm threshold and notification list).

#### Connection continuity checking:

- To the Senside e-Collector.
- To the machine control devices (PLC, PC).

#### Options:

- Data logging and history storing.
- Online documentation sharing.
- Brand labelling (portal personalization with customer logo and brand).

### Benefits

- A yearly subscription, no initial investment.
- A turnkey platform "ready to use".
- A better control over installation and process tuning.
- A common diagnostic tool, to be shared between machine builder/system integrator and user.
- A continuous feedback on the performances of the installed base.

### Contacts

Cedric de la Chapelle, Head of Marketing

**Senside**

Tel: + 33 1 41 29 82 25

E-mail: [contact@senside.com](mailto:contact@senside.com)

Website: [www.senside.com](http://www.senside.com)

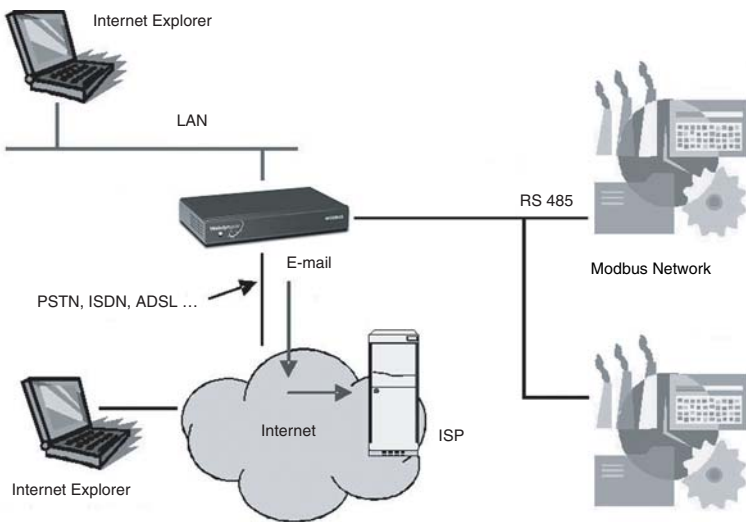
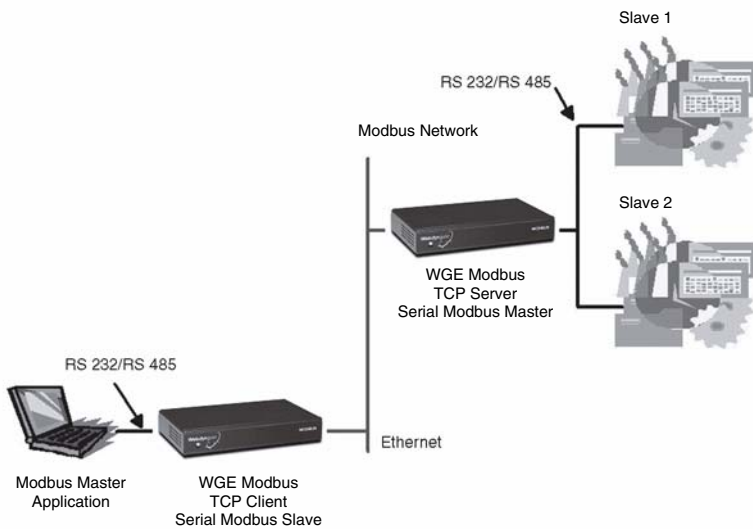

### Webdyn Presentation

Webdyn, a French company created in 1997, is a European leader in Internet gateways. It develops and manufactures hardware and software solutions, dedicated to the emerging embedded Internet market for industrial, audiovisual and residential equipment. Webdyn solutions are used in a wide range of industrial applications in Building Automation, Energy, Environment, Automation and Telecom.

### Webdyngate Easy

Webdyngate Easy allows you to transform a serial industrial network into a TCP/IP network. Thanks to the WGE-M all the functions defined within the Modbus protocol are included: serial master/slave, TCP/IP client/server. To secure the network and your industrial process, a redundancy option can be added to the gateway.

By using a WGE-S version together with serial/IP Gate PC software, industrial equipment can be monitored through TCP/IP link. This gateway is particularly suited to applications dedicated to PLC supervision (ie: PL7 Pro, TwidoSoft, Crouzet Logic Software and more).

### Webdyngate Power

The Webdyngate Power allows you to develop and personalize remote management and maintenance applications using standard tools (Web Browser, E-mail server) and protocols (TCP/IP, HTTP, SMTP).

This gateway offers different levels of personalization. A complete portal can be developed and stored in the gateway flash disk. In order to meet specific customer requirements, dedicated Plug-in DLL in "C" can be added to the gateway. Thanks to the embedded Java Virtual Machine, "Java" applications can be executed directly on the gateway.

The WGP version is compatible with the Modbus, Profibus and Uni-Te protocols. The customer can configure and manage industrial equipment with standard HTML pages using any Web Browser.

A V90 or GSM/GPRS modem may be embedded in the gateway.

### Contacts

Jacques Tabor, Channel Sales Manager  
**Webdyn S.A.**

- Tel: +33 (0)1 39 04 29 62
- Fax: +33 (0)1 39 04 29 41
- E-Mail: [contact@webdyn.com](mailto:contact@webdyn.com)
- Website: [www.webdyn.com](http://www.webdyn.com)

# Product reference index

## 1

140 CPU 651 50	105
140 CPU 651 60	105
140 NOE 771 01	106
140 NOE 771 11	106
140 NWM 100 00	106
140 NWM 100 00	115
170 ENT 110 01	78
170 ENT 110 02	78
171 CCC 960 20	98
171 CCC 960 30	98
171 CCC 980 20	98
171 CCC 980 30	98
174 CEV 200 40	90
174 CEV 300 20	90

## 4

490 NOC 000 05	125
490 NOR 000 03	125
490 NOR 000 05	125
490 NOR 000 15	125
490 NOR 000 05	125
490 NTC 000 05	125
490 NTC 000 05U	125
490 NTC 000 15	125
490 NTC 000 15U	125
490 NTC 000 40	125
490 NTC 000 40U	125
490 NTC 000 80	125
490 NTC 000 80U	125
490 NTW 000 02	125
490 NTW 000 02U	125
490 NTW 000 05	125
490 NTW 000 05U	125
490 NTW 000 12	125
490 NTW 000 12U	125
490 NTW 000 40	125
490 NTW 000 40U	125
490 NTW 000 80	125
490 NTW 000 80U	125
499 NEH 104 10	120
499 NEH 141 00	120
499 NES 181 00	123
499 NES 251 00	122
499 NES 271 00	123
499 NMS 251 01	122
499 NMS 251 02	122
499 NOH 105 10	120
499 NOS 271 00	123
499 NSS 251 01	122
499 NSS 251 02	122
499 NSS 271 00	123
499 NTR 100 10	121
499 NTR 101 00	121
499 TWD 01100	100

## A

AM0 ETH 001 V000	81
AM0 ETH 002 V000	81

## E

ECC21	94
EGX 100MG	92
EGX 400MG	93

## M

MPC AN0 2NAA 00A	114
MPC AN0 2NAA 00N	114
MPC AN0 2NDA 00N	114
MPC BN0 2NAA 00B	114
MPC BN0 2NAA 00C	114
MPC BN0 2NAA 00N	114
MPC BN0 2NDA 00N	114
MPC BN0 5NDA 00N	114
MPC CN0 2NAA 00N	114
MPC CN0 2NDA 00N	114
MPC CN0 5NAA 00N	114
MPC CN0 5NAA 00N	114
MPC CN0 5NDA 00N	114
MPC KT5 2NAA 00A	113
MPC KT5 2NAA 00N	113
MPC KT5 5NAA 00A	113
MPC KT5 5NAA 00B	113
MPC KT5 5NAA 00N	113
MPC NA2 0NNN 00N	114
MPC NA5 0NNN 00N	114
MPC NB2 0NNN 00N	114
MPC NB5 0NNN 00N	114
MPC NT2 0NNN 00N	114
MPC NT5 0NNN 00N	114
MPC ST5 2NDJ 00T	113
MPC YN0 0CFE 00N	113
MPC YN0 0RAM 064	114
MPC YN0 0RAM 128	114
MPC YN0 0RAM 256	114
MPC YN0 0R●● KIT	114
MPC YN0 2RAM 512	113
MPC YN0 5RAM 512	113

## O

OTB 1E0 DM9LP	80
---------------	----

## P

PMX 1500●●●	95
PSP OE	92

## R

RJ45 CFG	92
----------	----

## S

SMS 121●●●	95
SMS 1500●●●	95
STB NIP 2212	79
STB XTS 1120	79
STB XTS 2120	79
STX XMP 4440	79

## T

TCS EAQ 0100	88
TCS ECL 1M1M 10S2	124 & 125
TCS ECL 1M1M 1S2	124 & 125
TCS ECL 1M1M 25S2	124 & 125
TCS ECL 1M1M 3S2	124 & 125
TCS ECL 1M1M 40S2	124 & 125
TCS ECL 1M1M 5S2	124 & 125
TCS ECL 1M3M 10S2	124 & 125
TCS ECL 1M3M 1S2	124 & 125
TCS ECL 1M3M 25S2	124 & 125
TCS ECL 1M3M 3S2	124 & 125
TCS ECL 1M3M 40S2	124 & 125
TCS ECL 1M3M 5S2	124 & 125
TCS ESU 051 F0	124 & 125
TLX CD 10OFS 30M	118
TLX CD FCHMI V1M	103, 106 & 115
TLX CD GTW 10M	104
TLX CD OFS 30M	118
TLX CD TCP50M	103
TLX CD UNOFS 30M	118
TLX CD10 GTW 10M	104
TLX CDUN GTW 10M	104
TLX LSDKC PL741M	103
TSX ETG 100	88
TSX ETG 1000	89
TSX ETG 1010	89
TSX ETW 315G1	110
TSX ETW 315R1	110
TSX ETW 315T1	110
TSX ETW 320G1P1	110
TSX ETW 320T1G1	110
TSX ETW 320T1P1	110
TSX ETW 320T1R1	110
TSX ETW 320T1S1	110
TSX ETW 330G1	109
TSX ETW 330T1	109
TSX ETW 3GANT1	109
TSX ETW 3GEXT1	109
TSX ETW 3PWR2	109
TSX ETY 110 WS	103
TSX ETY 4103	103
TSX ETY 5103	103
TSX ETZ 410	101
TSX ETZ 510	101
TSX FPP 20	112
TSX MBP 100	112
TSX P57 1634M	102
TSX P57 2623M	102
TSX P57 2634M	102
TSX P57 2823M	102
TSX P57 3623M	102
TSX P57 3634M	102
TSX P57 4634M	102
TSX P57 4823M	102
TSX P57 5634M	102
TSX PCI 57 204M	104
TSX PCI 57 454M	104

## T (continued)

TSX WMY 100	103 & 115
TWD LCAE 40DRF	99

## U

UNY SPU ZU CD20E	103
------------------	-----

## V

VJL SMD BTL V26M	116
VJL SMD BTM V26M	116
VJL SMD BTS V26M	116
VJL SMD BTX V26M	116
VJL SMD RTL V26M	116
VJL SMD RTM V26M	116
VJL SMD RTS V26M	116
VJL SMD RTX V26M	116
VW3 A3 310	82 & 83

XBT F024610	112
XBT F034610	112
XBT G2130	112
XBT G2330	112
XBT G4330	112
XBT G5230	112
XBT G5530	112
XBT G6330	112
XBT GT1130	112
XBT MEM16	112
XBT ZGM128	112
XBT ZGM64	112
XGK S1715503	84
XGK Z33ETH	85
XPS MF3022	107
XPS MF31222	107
XPS MF3502	107
XPS MF3522	107
XPS MF3542	107
XPS MF6022	108
XPS MFAI801	108
XPS MFAO801	108
XPS MFCIO2401	108
XPS MFDI2401	108
XPS MFDI3201	108
XPS MFDIO241601	108
XPS MFD0801	108
XPS MFWIN	107
XPS MFWIN	108
XZC C12 FCM 50B	124
XZC C12 FDM 50B	124
XZC P1164L	124
XZC P1264L	124



# The efficiency of Telemecanique branded *solutions*

Used in combination, Telemecanique products provide quality solutions, meeting all your **Automation & Control** applications requirements.

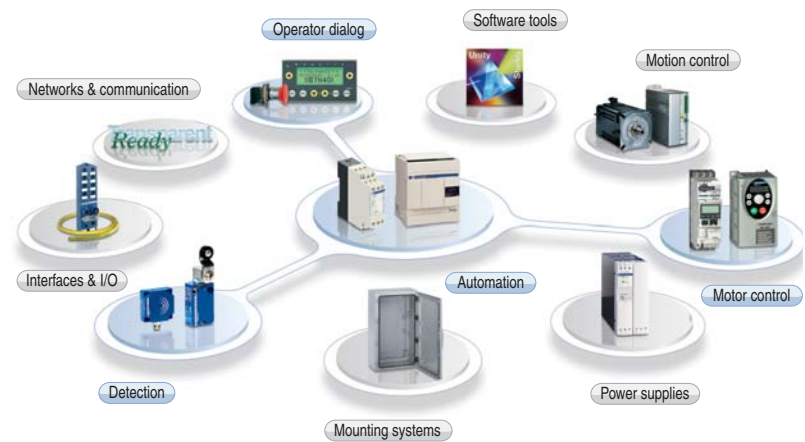

## A worldwide presence

### Constantly available

- More than 5 000 points of sale in 130 countries.
- You can be sure to find the range of products that are right for you and which complies fully with the standards in the country where they are used.

### Technical assistance wherever you are

- Our technicians are at your disposal to assist you in finding the optimum solution for your particular needs.
- Schneider Electric provides you with all necessary technical assistance, throughout the world.



### Schneider Electric Industries SAS

Head Office  
89, bd Franklin Roosevelt  
92506 Rueil-Malmaison Cedex  
France

[www.schneider-electric.com](http://www.schneider-electric.com)  
[www.telemecanique.com](http://www.telemecanique.com)

Due to evolution of standards and equipment, the characteristics indicated in texts and images of this document do not constitute a commitment on our part without confirmation.

Design: Schneider Electric  
Photos: Schneider Electric  
Printed by:

*Simply Smart !*