

A

B

C

D

A

B

C

D

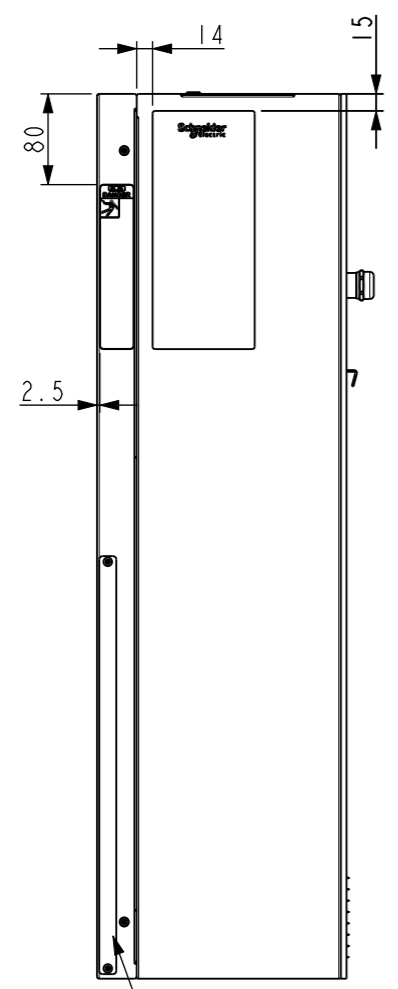

Includes aluminium filter

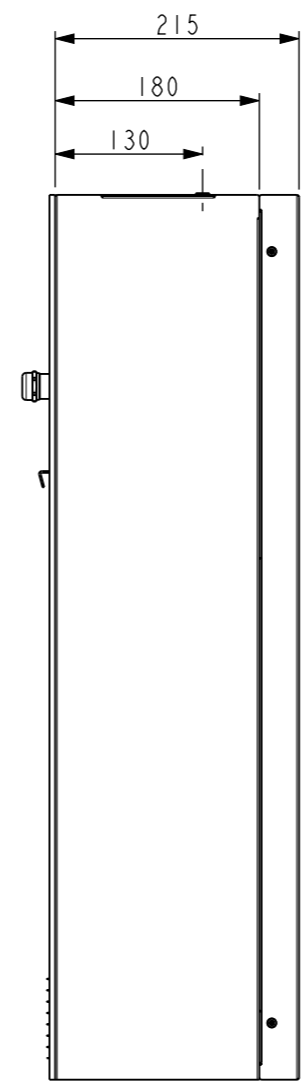
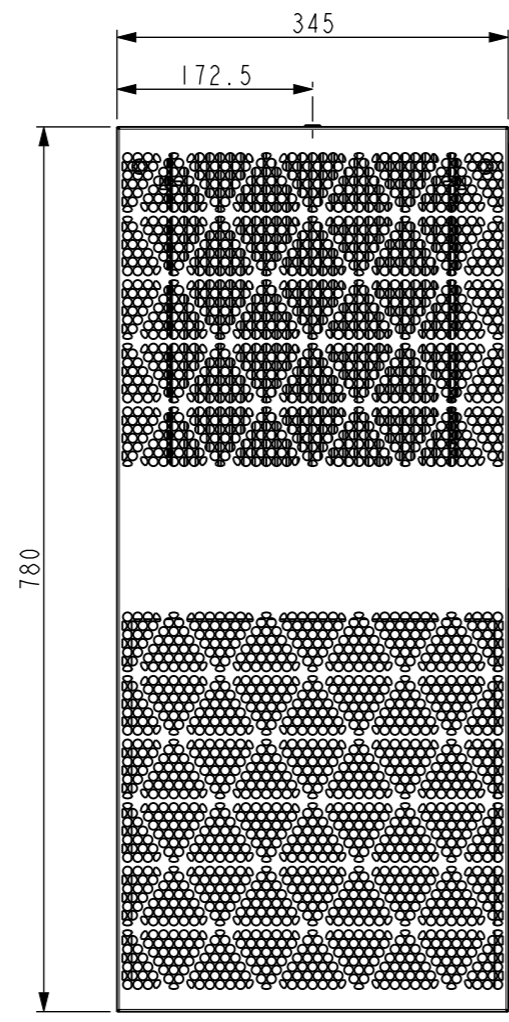

Electronic controller in the enclosure side

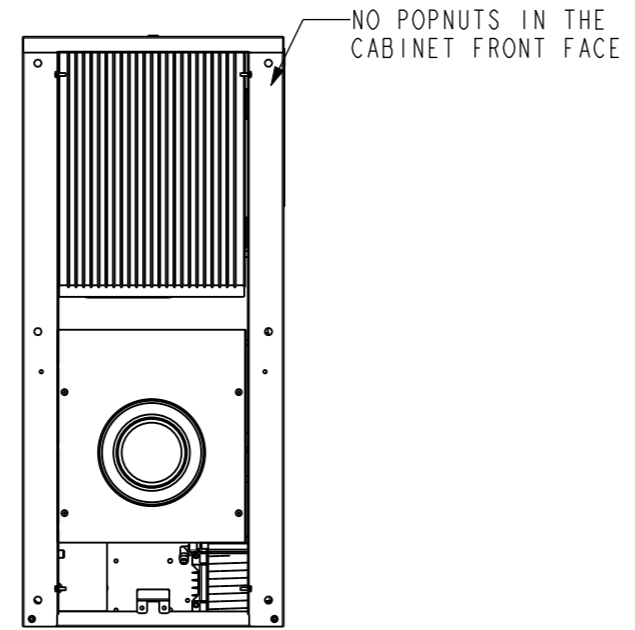
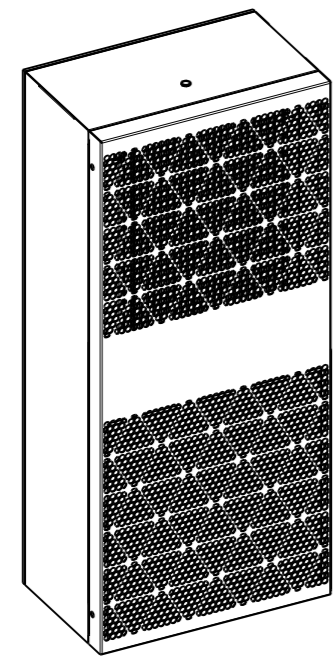
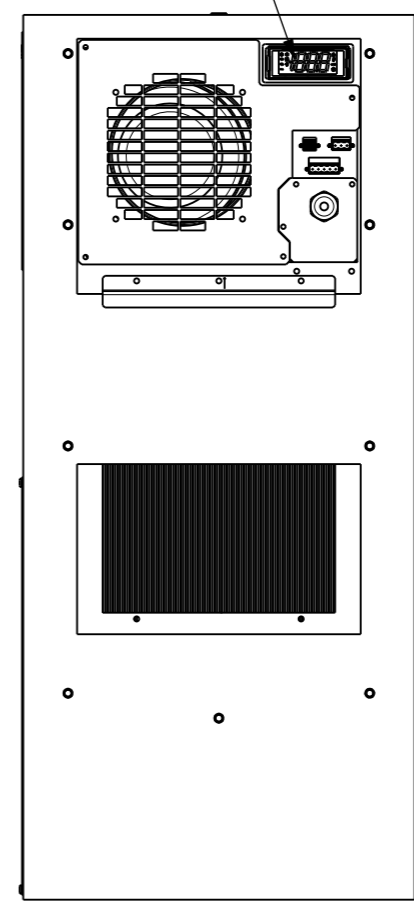

SCALE 0.100

COMMERCIAL REFERENCE	WEIGHT
NSYCUHD800DG	22.4 kg
NSYCUHDIKDG	22.4 kg
NSYCUHDIK2P4DG	27.4 kg

	Scale: 0.150 Technical Specification:	Units of measure: mm
	Document Description: CONNECT OUTDOOR COOL UNIT SIDE 800W 1KW	Document Number: GEX8222803
The information is highly confidential and is the exclusive property of Schneider Electric copyright reserved. This drawing must not be used for any purpose other than that expressly permitted in writing by the owners and must not be disclosed or reproduced in any way without permission from the owners in writing. This drawing must be returned to the owners when the purpose has ceased.		Doc. Rev. Sheet: 00.9 1/2

Released for Manufacturing
Printed on 2024/06/12

A

B

C

D

FIXING POINTS

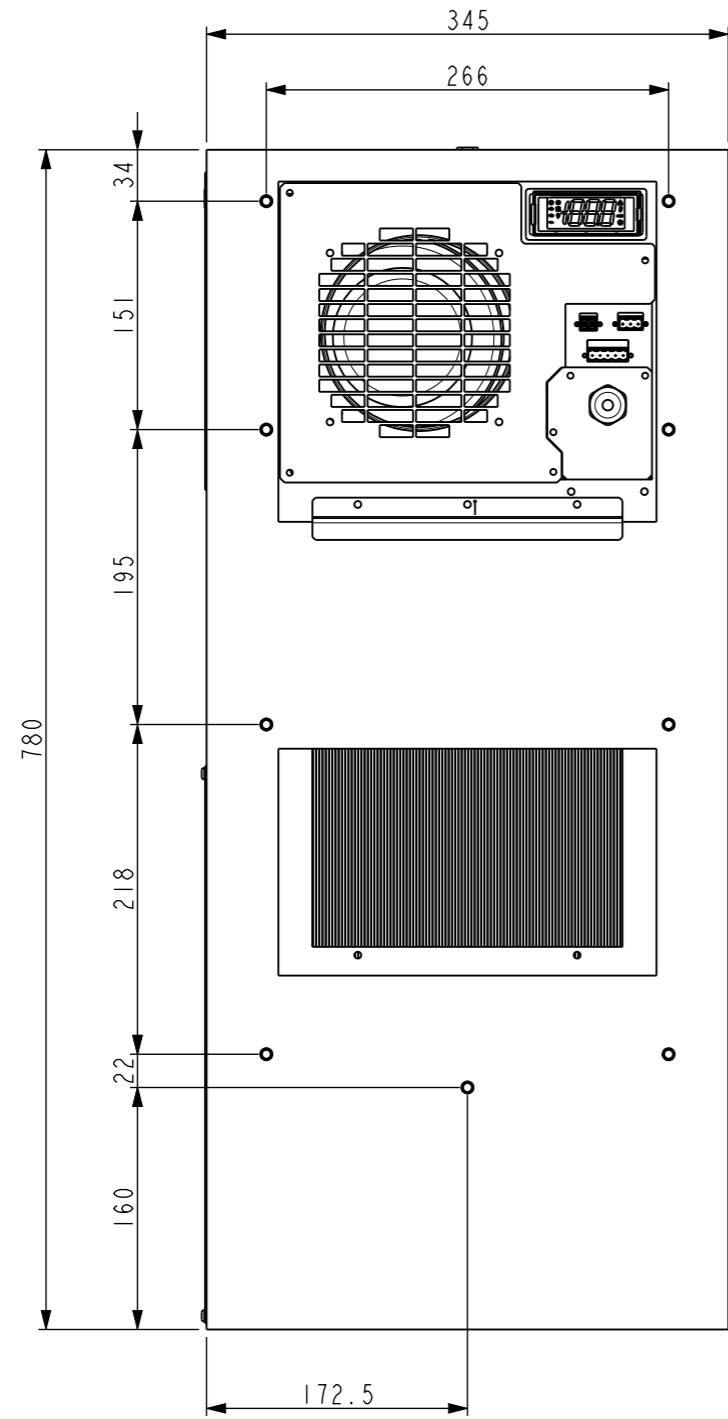

CUT OUT

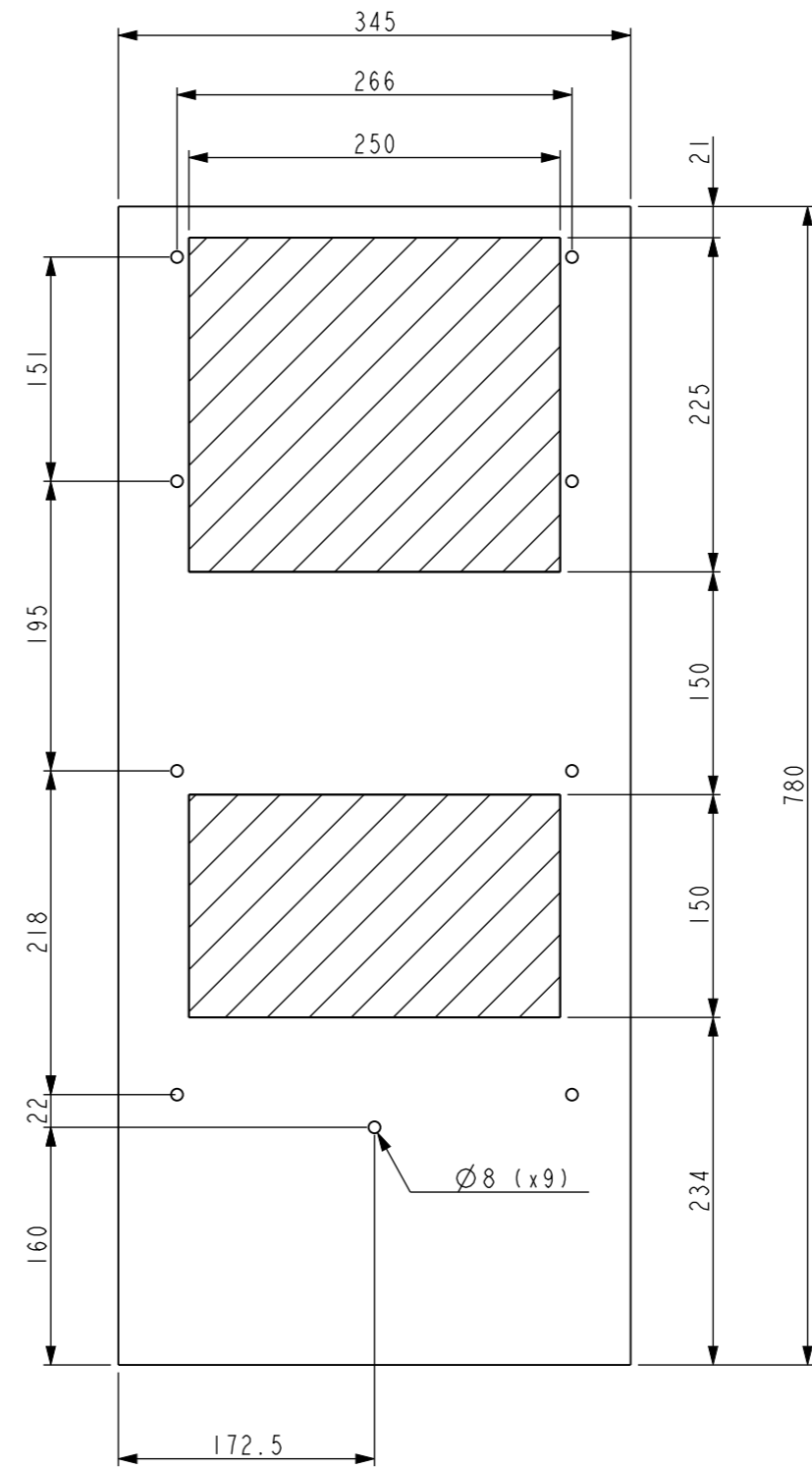

A

B

C

	Scale: 0.200	Technical Specification:	Units of measure: mm
		Document Description: CONNECT OUTDOOR COOL UNIT SIDE 800W 1KW	
		Document Number: GEX8222803	Doc. Rev. Sheet: 00.9 2/2

The information is highly confidential and is the exclusive property of Schneider Electric copyright reserved. This drawing must not be used for any purpose other than that expressly permitted in writing by the owners and must not be disclosed or reproduced in any way without permission from the owners in writing. This drawing must be returned to the owners when the purpose has ceased.

Released for Manufacturing
Printed on 2024/06/12