

	Scale: NTS	Technical Specification:	Units of measure : in
	Document Description: APVH362SSGL_CUSTOMER-DRAWING		
Document Number: APVH362SSGL_CUSTOMER-DRAWING		Doc. Rev.:	Sheet:
		00	1/3
<small>The information is highly confidential and is the exclusive property of Schneider Electric. It is not to be disclosed or reproduced in any way without permission from the Schneider Electric Group. This drawing must not be modified in any way without the express permission of Schneider Electric.</small>			State: <b>Provisional</b>

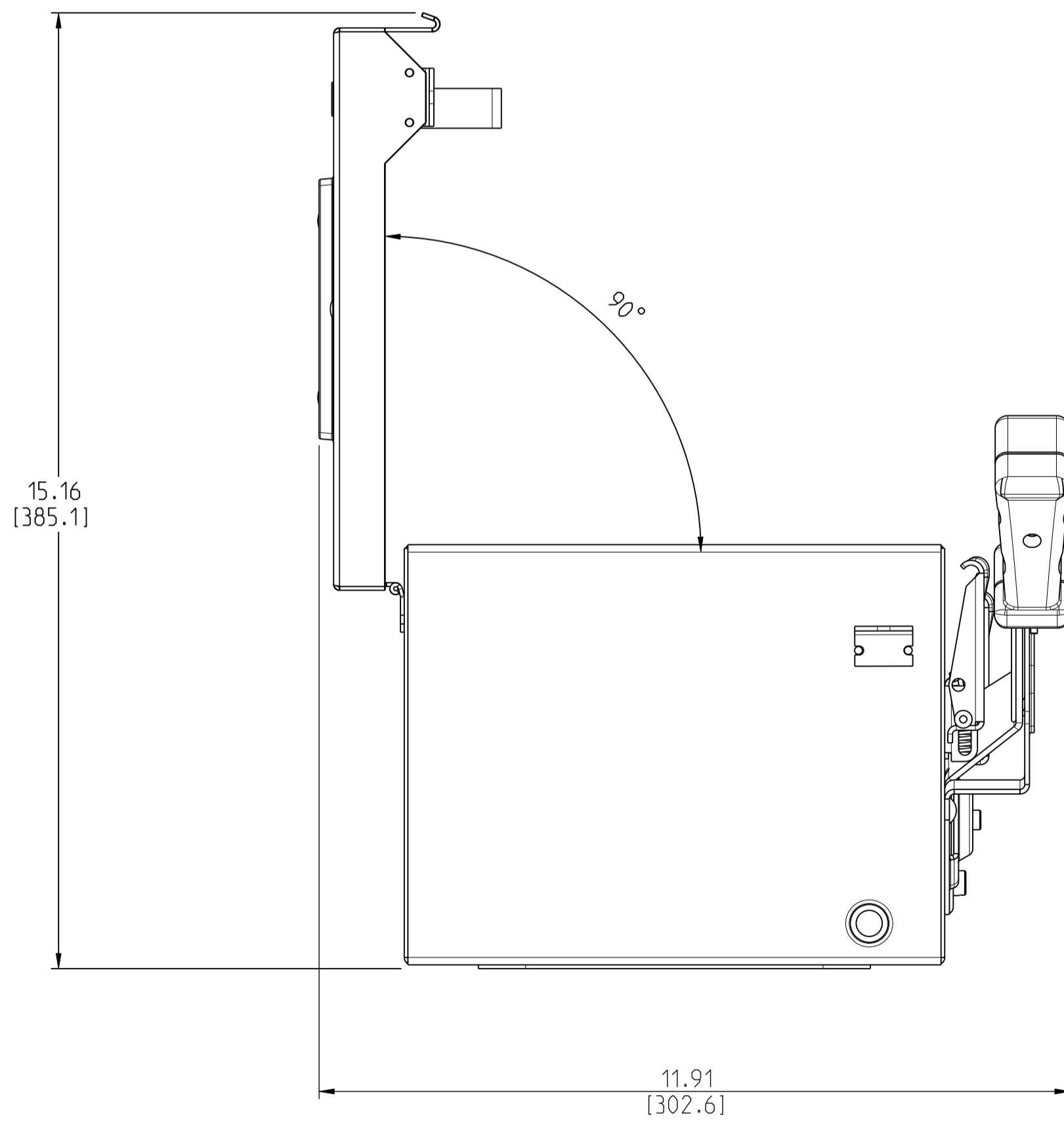
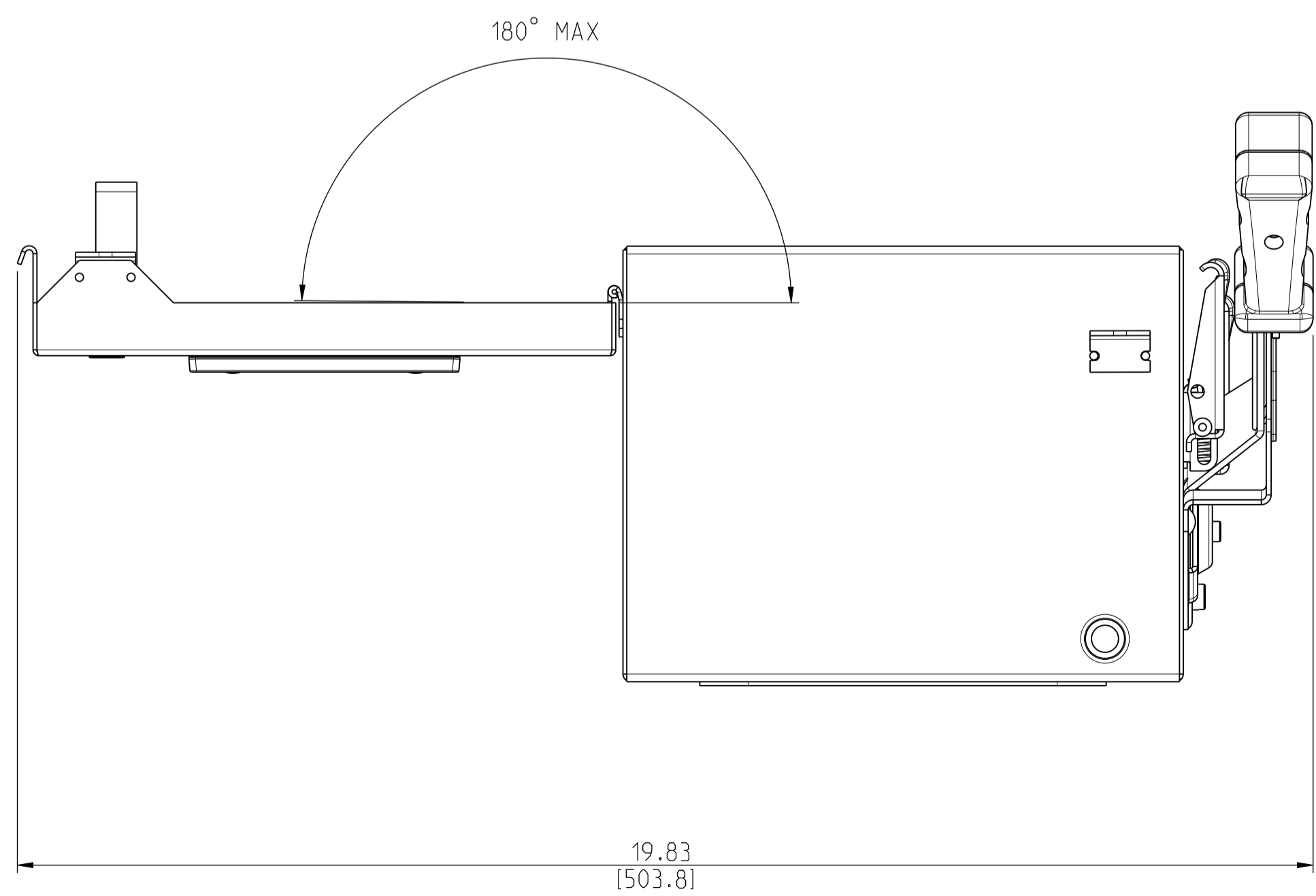
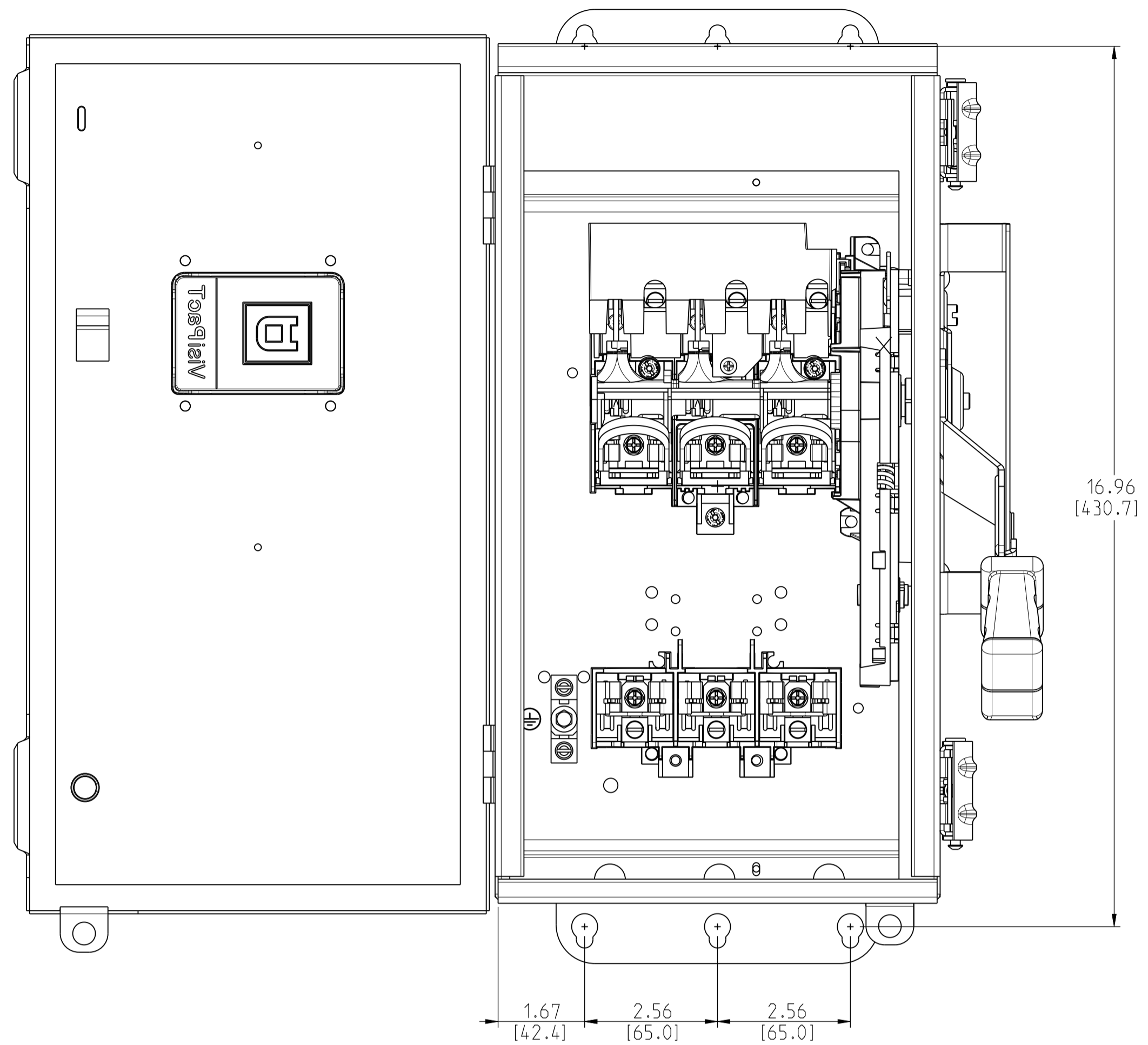

	Scale: NTS	Technical Specification:	Units of measure: in
	Document Description: <b>APVH362SSGL_CUSTOMER-DRAWING</b>		Doc. Rev. Sheet: <b>00</b> / 2/3
Document Number: <b>APVH362SSGL_CUSTOMER-DRAWING</b>		State:	

The information is highly confidential and is the exclusive property of Schneider Electric. Copyright reserved. This drawing must not be used for any purpose other than that expressly permitted in writing by the vendor and shall not be disclosed or reproduced in any way without permission from the vendor in writing. This drawing shall be returned to the vendor when the contract has ended.

CATALOG NUMBER	VOLTAGE RATING	AMPERAGE RATING
VH362SSGL	600 VAC/VDC	60A

HORSEPOWER RATINGS			
VOLTS	Ø	STD	MAX
240V~	1	3	10
240V~	3	7.5	15
480V~	1	5	20
480V~	3	15	30
600V~	3	15	50
250V=	--	10	--
600V=	--	25	30

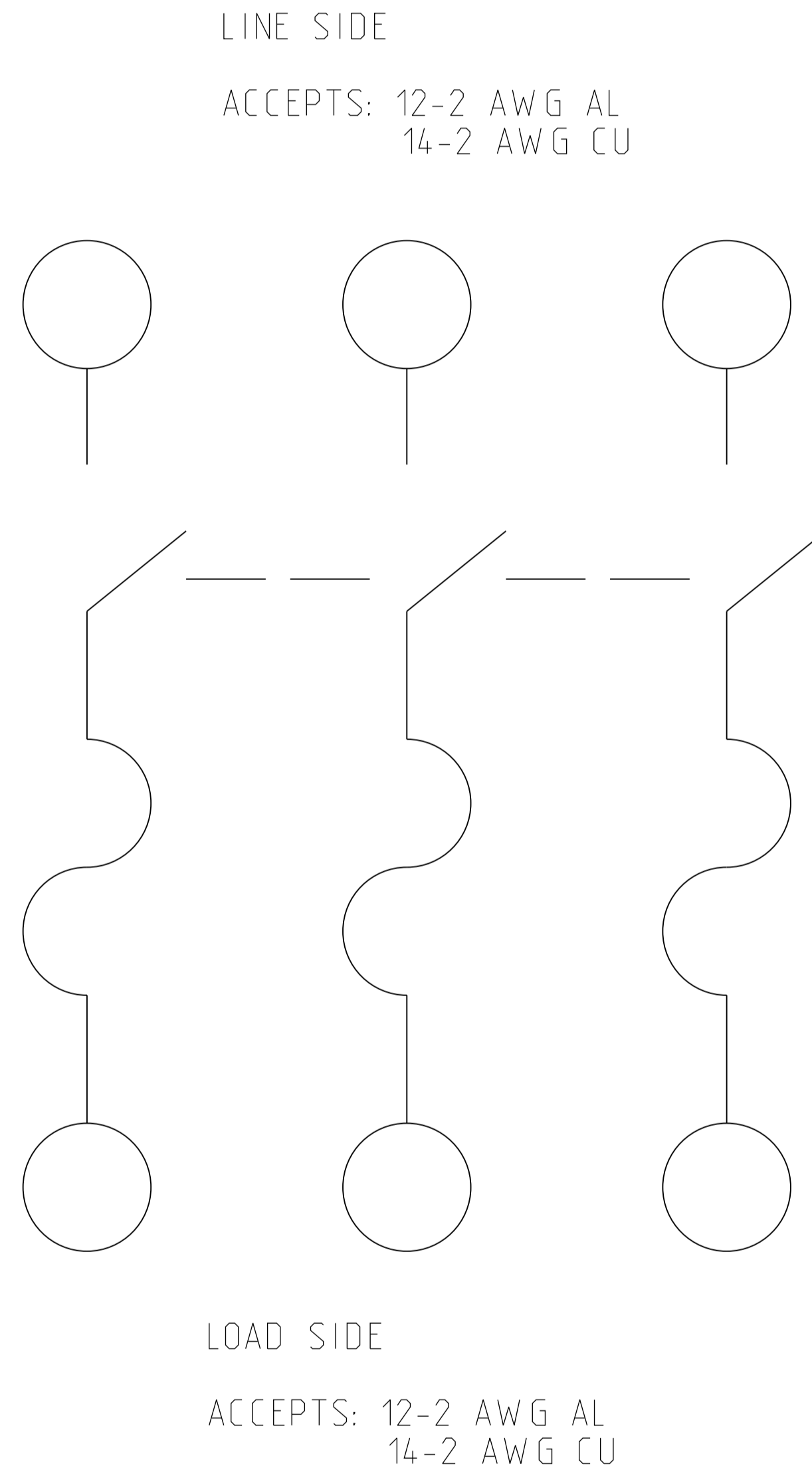

KIT	ACCESSORIES	
	VOLTAGE	PART NUMBER
ELECTRICAL INTERLOCK	600V	EIK1, EIK2
	240V	EIK031, EIK032
CLASS R FUSE KITS	600V	RFK03H, RFK06
	240V	RFK03L
INTERNAL BARRIER	600V	SS06
	240V	SS03
FUSE PULLER	600V	FPK0610
	240V	FPK03
SOLID NEUTRAL ASSEMBLY	600V	SN0610 for Al SN0610C for Cu
	240V	SN03 for Al SN03C for Cu
EQUIPMENT GROUNDING KIT	600V	GTK0610 for Al GTK0610C for Cu
	240V	GTK03 for Al GTK03C for Cu
TOUCH UP PAINT	600V & 240V	PK49SP
LOCK OFF/ON	600V	LOGK2
	240V	LOGK1
COPPER LUGS	600V & 240V	CL0306F

	Scale: NTS	Technical Specification:	Units of measure: in
	Document Description: APVH362SSGL_CUSTOMER-DRAWING		
Document Number: APVH362SSGL_CUSTOMER-DRAWING		Doc. Rev.:	Sheet:
		00	3/3

The information is highly confidential and is the exclusive property of Schneider Electric. It is written for the experts and may not be disclosed or reproduced in any way without permission from the experts in writing. This drawing may be returned to the factory when the product has been tested.