REPLACEMENT PARTS

NF Panelboards Main Lugs and Main Circuit Breaker

CONTENTS

Panelboard Type and Rating	Page
250 Ampere Maximum	2
600 Ampere Maximum	4
Modifications	6
Accessories	8



SQUARE D
GROUPE SCHNEIDER

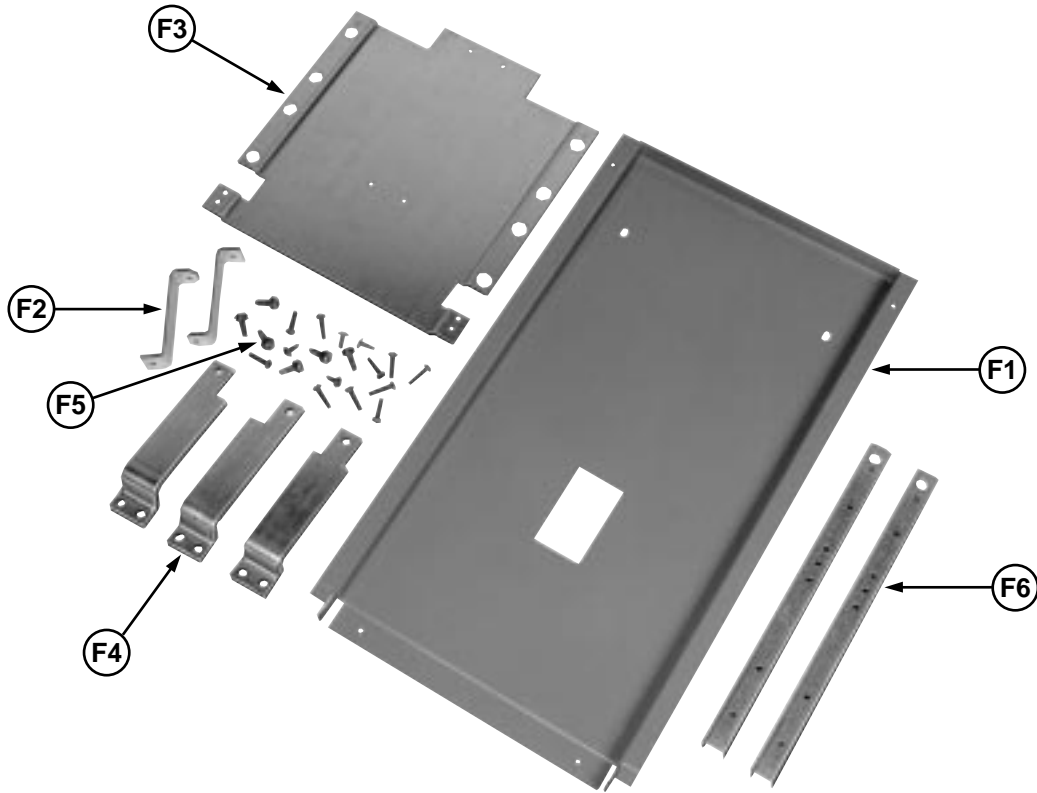

F. 250 A Main Circuit Breaker Kit

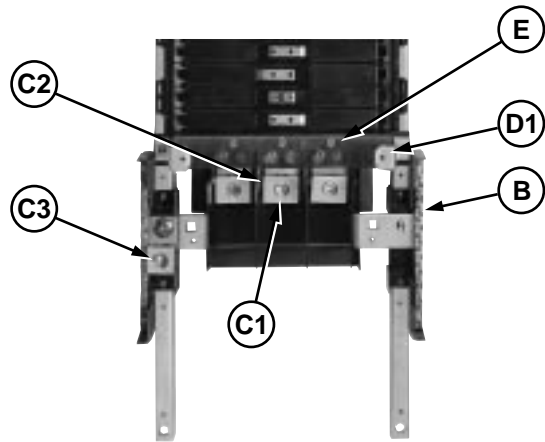

A. 250 A Interior



DANGER: HAZARD OF ELECTRIC SHOCK, BURN OR EXPLOSION. Turn off all power supplying this equipment before working on it. Failure to observe this instruction will result in death or serious injury.

Table 1: 125/250 A Interiors

Code Letter	Description	Part Number							
		1-12 Circuits	13-18 Circuits	19-30 Circuits	31-42 Circuits	43-54 Circuits			
A	Main Lug Interior								
	1PH3W	125 A	NF12L1	NF18L1	—	—	—		
		250 A	NF12L1C	NF18L1C	—	—	—		
	3PH4W	125 A	NF412L1	NF418L1	NF430L1	—	—		
		250 A	NF412L1C	NF418L1C	NF430L1C	—	—		
		125 A	—	—	NF430L2	NF442L2	NF454L2		
		250 A	—	—	NF430L2C	NF442L2C	NF454L2C		
	B	Solid Neutral Assembly							
B1		125 A	80114-045-50	80114-045-51	80114-045-52	—	—		
		250 A	—	—	80114-009-50	80114-009-51	80114-009-52		
B2		Neutral Insulator Kit	80113-283-50	80113-283-50	80113-283-50	80113-283-50	80113-283-50		
		Neutral Insulator Cover	80113-057-01	80113-057-01	80113-057-01	80113-057-01	80113-057-01		
Neutral Bonding Strap		80114-034-01	80114-034-01	80114-034-01	80114-034-01	80114-034-01			
Screw, Neutral Bonding Strap	(2) 80114-005-01	(2) 80114-005-01	(2) 80114-005-01	(2) 80114-005-01	(2) 80114-005-01				
C	Lugs								
	C1	Main Lug	125 A	80114-031-01	80114-031-01	80114-031-01	—		
		Screw, Main Lug Mtg.	250 A	—	—	80114-031-01	80114-031-01		
	C2	Vertical Lug Barrier	125 A	80113-005-01	80113-005-01	80113-005-01	80113-005-01		
		Neutral Main Lug Kit	250 A	—	—	80114-040-53	80114-040-53		
	D	Interior Deadfront Trim▲							
▲		Main Lugs Deadfront	125 A	80113-170-50	80113-170-50	80113-170-50	80113-170-50		
		250 A	80113-171-50	80113-171-50	80113-171-50	80113-171-50	80113-171-50		
▲		Branch Deadfront	1PH3W	125 A	NFRPL12L1	NFRPL18L1	—	—	
			3PH4W	125 A	NFRPL412L1	NFRPL418L1	—	—	
			1PH3W	250 A	—	—	NFRPL30L2	NFRPL42L2	NFRPL54L2
			3PH4W	250 A	—	—	NFRPL430L2	NFRPL442L2	NFRPL454L2
▲		Load End Deadfront	125 A	80113-174-57	80113-174-50	80113-174-50	—		
	250 A		—	—	80113-175-50	80113-175-50	80113-175-50		
D1	Screw, Deadfront Mtg.	—	80114-004-01	80114-004-01	80114-004-01	80114-004-01			
	Deadfront Support Bracket	—	80113-051-01	80113-051-01	80113-051-01	80113-051-01			
E	Line End Barrier Kit	—	80114-005-01	80114-005-01	80114-005-01	80114-005-01			
		—	80113-270-50	80113-270-50	80113-270-50	80113-270-50			

Table 2: 100/250 A Main Circuit Breaker

Code	Description	Part Number				
		125 A Main Circuit Breaker	N100M★	N100MFC■	N100MFI◆	N250MKC●
	Main Circuit Breaker Kit	Factory Assembled, EDB	FDL, FGL & FJL	FCL	FIL	KAL, KHL, KCL & KIL
F1	Mains End Deadfront	—	80113-170-55	80113-170-60	80113-171-51	80113-171-51
	Screw, Deadfront Mounting	—	80114-004-01	80114-004-01	80114-004-01	80114-004-01
F2	Deadfront Support Bracket	—	80113-051-02	80113-051-02	80113-051-02	80113-051-02
	Screw, Support Bracket Mounting	—	80114-005-01	80114-005-01	80114-005-01	80114-005-01
F3	Main Circuit Breaker Mounting Pan	—	80113-071-01	80113-293-01	80113-079-01	80113-079-01
	Screws, Mounting Pan	—	80113-277-50	80113-277-50	80113-277-50	80113-277-50
F4	Main Bus Connector	A PH	—	80113-076-01	80113-284-50	80113-276-50
		● B PH	—	80113-275-50	80113-284-51	80113-276-51
		C PH	—	80113-073-01	80113-284-50	80113-276-52
F5	Connector Screw Kit (Per phase)	—	80113-278-50	80113-294-50	80113-279-50	80113-279-50
F6	Rail Extension Kit	—	80113-070-51	80113-070-51	80113-070-51	80113-070-51
	Mounting Pan Insulator	—	80113-072-01	—	—	—
▲	Bus Connector Cover Assembly	—	80113-271-50	—	—	—

- ▲ Not shown.
- Not required on single-phase devices.
- ★ The same parts are used in the following assemblies: N2100FDMB, N2100FGMB, N3100FDMB and N3100FGMB.
- The same parts are used in the following assemblies: N2100FCMB and N3100FCMB.
- ◆ The same parts are used in the following assemblies: N2100FIMB and N3100FIMB.
- The same parts are used in the following assemblies: N2250KAMB, N2250KCMB, N2250KHMB, N2250KIMB, N3250KAMB, N3250KCMB, N3250KHMB and N3250KIMB.

⚠ DANGER: HAZARD OF ELECTRIC SHOCK, BURN OR EXPLOSION. Turn off all power supplying this equipment before working on it. Failure to observe this instruction will result in death or serious injury.

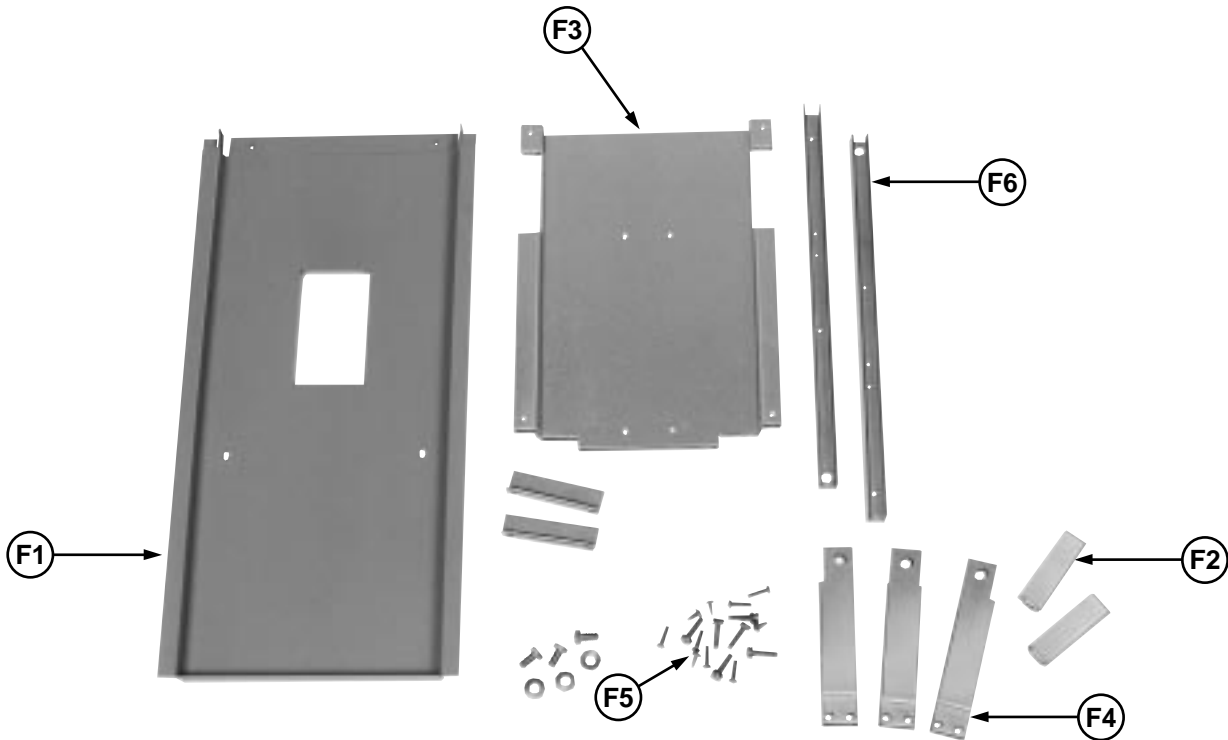

F. 400 A Main Circuit Breaker Kit

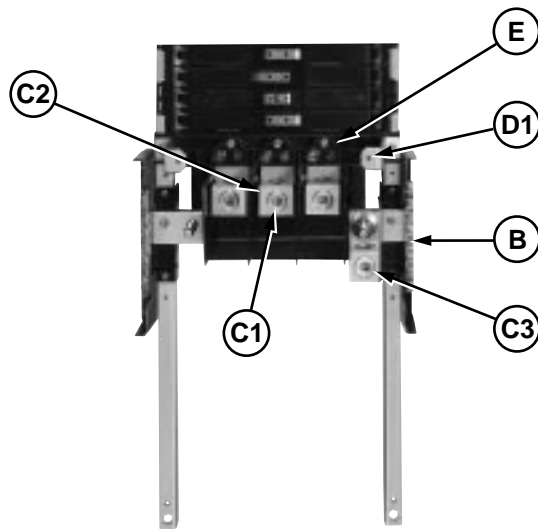

A. 400 A Interior



DANGER: HAZARD OF ELECTRIC SHOCK, BURN OR EXPLOSION. Turn off all power supplying this equipment before working on it. Failure to observe this instruction will result in death or serious injury.

Table 3: 400/600 A Interiors

Code Letter	Description	Part Number					
		1-30 Circuits	31-42 Circuits	43-54 Circuits			
A	Main Lug Interior						
	1PH3W	400 A	NF30L4	NF42L4	NF54L4		
		600 A	NF30L4C	NF42L4C	NF54L4C		
	3PH4W	400 A	NF30L6C	NF42L6C	NF54L6C		
		600 A	NF430L4	NF442L4	NF454L4		
			NF430L4C	NF442L4C	NF454L4C		
		NF430L6C	NF442L6C	NF454L6C			
B	Solid Neutral Assembly						
		400 A	80114-010-50	80114-010-51	80114-010-52		
		600 A	80114-012-50	80114-012-51	80114-012-52		
	▲	Neutral Bonding Strap		(2) 80114-034-01	(2) 80114-034-01		
	Screw, Neutral Bonding Strap		(2) 80114-005-01	(2) 80114-005-01			
C	Lugs						
	C1	Main Lug	400 A	80114-100-01	80114-100-01	80114-100-01	
				600 A	80114-054-01	80114-054-01	80114-054-01
		Screw, Main Lug Mtg.		(2) 80114-001-02	(2) 80114-001-02	(2) 80114-001-02	
	C2	Vertical Lug Barrier		80113-005-01	80113-005-01	80113-005-01	
	C3	Neutral Main Lug Kit	400 A	80114-040-54	80114-040-54	80114-040-54	
			600 A	80114-040-55	80114-040-55	80114-040-55	
	D	Interior Deadfront Trim▲					
▲		Main Lugs Deadfront	400 A	80113-178-50	80113-178-50	80113-178-50	
			600 A	80113-179-50	80113-179-50	80113-179-50	
▲		Branch Deadfront	1PH3W	400 A	NFRPL30L4	NFRPL42L4	NFRPL54L4
			3PH4W	400 A	NFRPL430L4	NFRPL442L4	NFRPL454L4
			1PH3W	600 A	NFRPL30L6	NFRPL42L6	NFRPL54L6
			3PH4W	600 A	NFRPL430L6	NFRPL442L6	NFRPL454L6
▲		Load End Deadfront	400 A	80113-182-50	80113-182-50	80113-182-50	
			600 A	80113-183-50	80113-183-50	80113-183-50	
		Screw, Deadfront Mtg.		80114-004-01	80114-004-01	80114-004-01	
D1		Deadfront Support Bracket		80113-051-01	80113-051-01	80113-051-01	
		Screw, Support Bracket Mtg.		80114-005-01	80114-005-01	80114-005-01	
E	Line End Barrier Kit		80113-270-50	80113-270-50	80113-270-50		

Table 4: 400 A Main Circuit Breaker

Code Letter	Description	Part Number	
	Main Circuit Breaker Kit	N400M	
	Main Circuit Breaker Type	LAL, LHL	
F1	Mains End Deadfront	80113-178-51	
	Screw, Deadfront Mtg.	80114-004-01	
F2	Deadfront Support Bracket	80113-051-02	
	Screw, Support Bracket Mounting	80114-005-01	
F3	Main Circuit Breaker Mounting Pan	80113-084-01	
	Screws, Mounting Pan	80113-277-50	
F4	Main Bus Connector	A PH	80113-280-50
		● B PH	80113-280-51
		C PH	80113-280-52
F5	Connector Screw Kit (Per phase)	80113-281-50	
F6	Rail Extension Kit	80113-070-51	

▲ Not shown.

● Not required on single-phase devices.

 **DANGER: HAZARD OF ELECTRIC SHOCK, BURN OR EXPLOSION.** Turn off all power supplying this equipment before working on it. Failure to observe this instruction will result in death or serious injury.

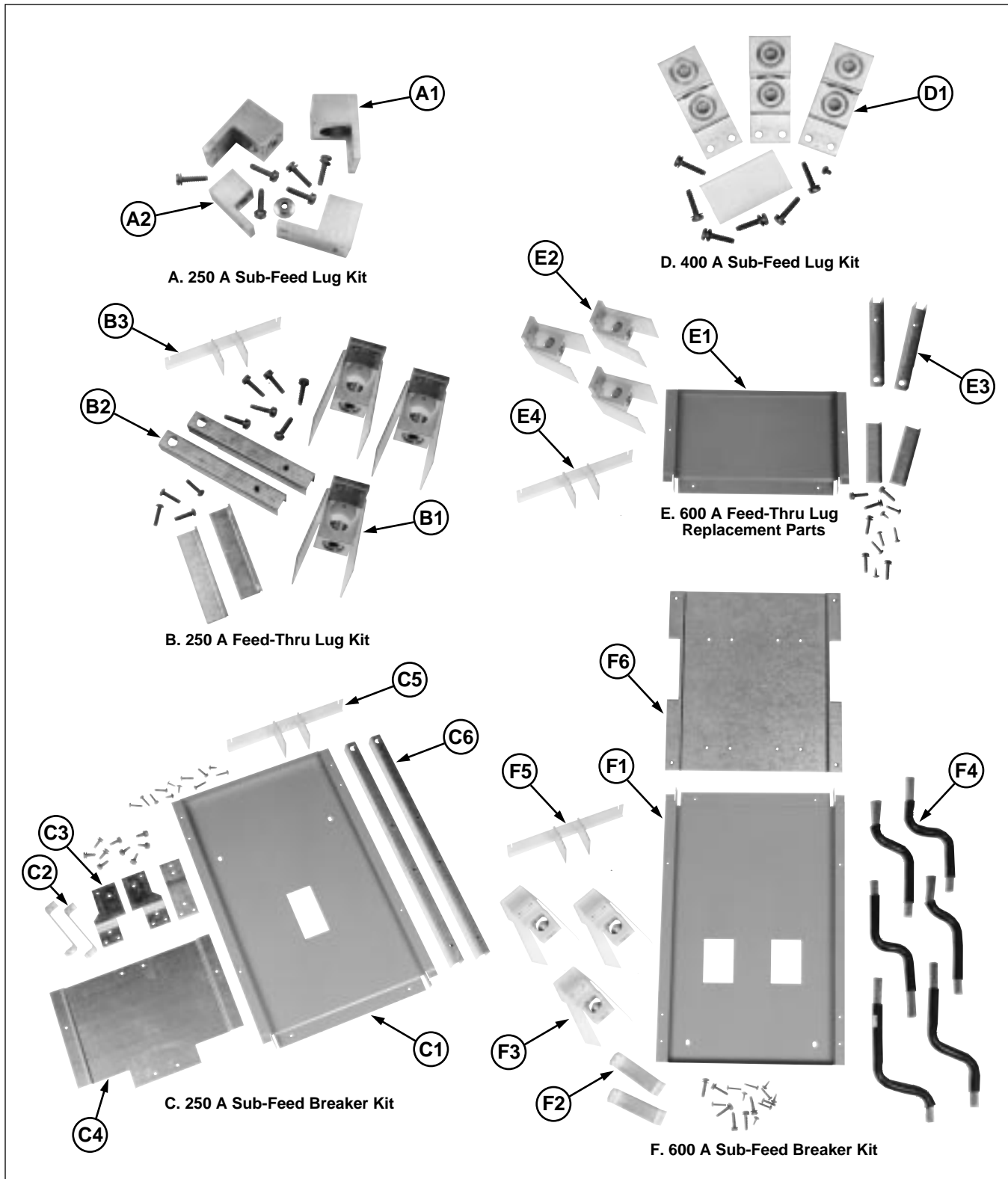

DANGER: HAZARD OF ELECTRIC SHOCK, BURN OR EXPLOSION. Turn off all power supplying this equipment before working on it. Failure to observe this instruction will result in death or serious injury.

Table 5: 125/250 A Modification – Replacement Parts

Code Letter	Description	Part Number				
		N125SFL	N125SFLC	N250SFL	N250SFLC	
A	Sub-Feed Lug Kit					
	A1 Main Lugs (per phase)	(2) 80110-194-01	(2) 80110-195-01	80114-100-01	80114-100-02	
	Screw, Line Lug Mtg. (per phase)	(2) 80114-001-01	(2) 80114-001-01	(2) 80114-001-01	(2) 80114-001-01	
	▲ Sub-Feed Lug Pad Assy. (per phase)	80114-178-53	80114-178-53	—	—	
	A2 Neutral Main Lug	80110-194-01	80110-195-01	80114-030-01	80114-030-02	
	Keps Nut, Neutral Lug Mtg.	23427-02200	23427-02200	23427-02200	23427-02200	
B	Feed-Thru Lug Kit	N125FTL	N125FTLC	N250FTL	N250FTLC	
	▲ Deadfront Trim	80113-174-51	80113-174-51	80113-175-51	80113-175-51	
	Screw, Deadfront Mtg.	80114-004-01	80114-004-01	80114-004-01	80114-004-01	
	▲ Deadfront Support Bracket	80113-051-02	80113-051-02	80113-051-02	80113-051-02	
	Screw, Support Bracket Mtg.	80114-005-01	80114-005-01	80114-005-01	80114-005-01	
	B1 A, B and C PH Line Lug Assy.	(3) 80114-233-50	(3) 80114-233-51	(3) 80114-233-50	(3) 80114-233-51	
	Screw, Line Lug Mtg.	(6) 80114-001-01	(6) 80114-001-01	(6) 80114-001-01	(6) 80114-001-01	
	▲ Neutral Main Lug	80110-194-01	80110-195-01	80114-030-01	80114-030-02	
	Keps Nut, Neutral Lug Mtg.	23427-02200	23427-02200	23427-02200	23427-02200	
	B2 Rail Extension Kit	80113-070-50	80113-070-50	80113-070-51	80113-070-51	
	B3 Line End Barrier	80113-270-50	80113-270-50	80113-270-50	80113-270-50	
	C	Sub-Feed Breaker Kit	N250SFB1KC/N250SFBKC			
C1 Deadfront Trim		80113-175-52	—	—	—	
Screw, Deadfront Mtg.		80114-004-01	—	—	—	
C2 Deadfront Support Bracket		80113-051-02	—	—	—	
Screw, Support Bracket Mtg.		80114-005-01	—	—	—	
C3 Connector		A PH	80113-282-50	—	—	—
		● B PH	80113-282-51	—	—	—
		C PH	80113-282-52	—	—	—
Connector Screw Kit (Per phase)		80113-279-50	—	—	—	
C4 Mounting Pan		80113-218-01	—	—	—	
Screw, Pan Mtg.		(4) 80114-005-01	—	—	—	
C5 Line End Barrier		80113-270-50	—	—	—	
C6 Rail Extension Kit	80113-070-52	—	—	—		

Table 6: 400/600 A Modification – Replacement Parts

Code Letter	Description	Part Number				
		N400SFL	N400SFLC	N600SFL	N600SFLC	
D	Sub-Feed Lug Kit					
	D1 A and C PH Main Lug Assy.	(2) 80114-054-01	(2) 80114-054-02	—	—	
	B PH Main Lug Assy.	(1) 80114-183-50	(1) 80114-183-51	—	—	
	Screw, Line Lug Mtg.	(6) 80114-001-02	(6) 80114-001-02	—	—	
	▲ Neutral Main Lug	40251-136-50	80048-002-01	—	—	
	Keps Nut, Neutral Lug Mtg.	23427-02800	23427-02800	—	—	
E	Feed-Thru Lug Kit	N400FTL	N400FTLC	—	—	
	E1 Deadfront Trim	80113-182-51	80113-182-51	80113-183-51	80113-183-51	
	Screw, Deadfront Mtg.	80114-004-01	80114-004-01	80114-004-01	80114-004-01	
	E2 A, B and C PH Line Lug Assy.	(3) 80114-234-50	(3) 80114-234-51	(3) 80114-183-50	(3) 80114-183-51	
	Screw, Line Lug Mtg.	(6) 80114-001-02	(6) 80114-001-02	(6) 80114-001-02	(6) 80114-001-02	
	▲ Neutral Main Lug	40251-136-50	80048-002-01	40251-287-50	80048-002-01	
	Keps Nut, Neutral Lug Mtg.	23427-02800	23427-02800	23427-02800	23427-02800	
	E3 Rail Extension Kit	80113-070-50	80113-070-50	80113-070-50	80113-070-50	
	E4 Line End Barrier	80113-270-50	80113-270-50	—	—	
	F	Sub-Feed Breaker Kit	N600SFB1KC	N600SFB2KC/N600SFBKC	—	—
		F1 Deadfront Trim	80113-183-55	80113-183-56	—	—
		▲ Closing Plate	80113-228-01	—	—	—
Screw, Deadfront Mtg.		80114-004-01	80114-004-01	—	—	
F2 Deadfront Support Bracket		80113-051-02	80113-051-02	—	—	
Screw, Support Bracket Mtg.		80114-005-01	80114-005-01	—	—	
F3 A, B and C PH Line Lug Assy.		(3) 80113-230-50	(3) 80113-230-50	—	—	
Screw, Line Lug Mtg.		(6) 80114-001-02	(6) 80114-001-02	—	—	
F4 Cable Connector		A PH	80113-226-01	80113-226-01	—	—
		—	—	80113-226-04	—	—
		● B PH	80113-226-02	80113-226-02	—	—
		—	—	80113-226-05	—	—
F4 Cable Connector		C PH	80113-226-03	80113-226-03	—	—
		—	—	80113-226-06	—	—
F5 Line End Barrier		80113-270-50	80113-270-50	—	—	
F6 Mounting Pan		80113-225-01	80113-225-01	—	—	
▲ Screw, Pan Mtg.		(4) 80114-005-01	(4) 80114-005-01	—	—	
▲ Line End Barrier		80113-270-50	80113-270-50	—	—	
▲ Rail Extension Kit	80113-070-52	80113-070-52	—	—		
▲ Vertical Barrier	80113-005-01	80113-005-01	—	—		

▲ Not shown. ● Not required on single-phase devices.

⚠ DANGER: HAZARD OF ELECTRIC SHOCK, BURN OR EXPLOSION. Turn off all power supplying this equipment before working on it. Failure to observe this instruction will result in death or serious injury.

Table 7: NF Panelboard Accessories

	Description	Catalog Number
Not Shown	Circuit I.D. number strips:	
	Odd/even #1-42 (5 per package)	NF42D
	Odd/even #55-84 (5 per package)	NF84D
	Sequential #1-42 (5 per package)	NF42S
	Sequential #55-84 (5 per package)	NF84S
Not Shown	Filler plate	EFP
Not Shown	Lock – NEMA Type 1 enclosures	PK22FL
Not Shown	Keys – (2) NSR-251 (for all locks)	LP9618
Not Shown	Directory card (10 per package)	NFDC
Not Shown	Plastic stick-on directory pouch (5 per package)	NFDCH
Not Shown	Nut – interior mounting (4 per package)	NFNIM
Not Shown	Leveling nut (flush mount only – 4 per package)	NFLN
Not Shown	Trim Mounting Screws/Hardware:	
	250 A max interiors (10 per package)	NFTMS1
	600 A max interiors (8 per package)	LP9502
Not Shown	125/250 A Branch Connector Kit	SKNF250
Not Shown	400/600 A Branch Connector Kit	SKNF600



DANGER: HAZARD OF ELECTRIC SHOCK, BURN OR EXPLOSION. Turn off all power supplying this equipment before working on it. **Failure to observe this instruction will result in death or serious injury.**

