

Zone Selective Interlocking (ZSI) Systems and Energy Reduction Maintenance Setting (ERMS) Switches in Electrical Distribution Systems

Retain for future use.

Introduction

This bulletin describes the basic principles of how Zone Selective Interlocking (ZSI) systems and Energy Reduction Maintenance Setting (ERMS) switches can be used with selective coordination to enable an efficient, safe, and effective electrical distribution system. The selective coordination of circuit breakers and electronic trip units with ERMS switches and ZSI capabilities localize system outages and reduce fault stress in electrical distribution systems.

Selective Coordination

Overcurrent Protection Devices (OCPDs) are used in electrical distribution systems to protect electrical conductors and equipment against the effects of short circuits, ground faults, and/or overloads. The OCPDs in an electrical distribution system are often selectivity coordinated so that the nearest device upstream of a detected fault will open and clear the detected fault before another farther upstream device opens. Selective coordination of OCPDs limits the number of distribution circuits that are de-energized by the operation of a device in response to a detected fault.

The OCPDs in an electrical distribution system can be circuit breakers having programmable electronic trip units for controlling the OCPD's trip settings. The circuit breakers employing these electronic trip units are known as **electronic trip circuit breakers** (see Figure 1).

For circuit breakers equipped with P- and H-Micrologic™ trip units, Schneider Electric has developed a method to temporarily reduce the instantaneous pickup setting of the circuit breaker using an Energy Reduction Maintenance Setting (ERMS) switch.

Figure 1 – Masterpact™ Circuit Breakers with Electronic Trip Units

NOTE: All Micrologic P- and H-trip units with the blue ERMS label are suitable for ERMS applications.



An electronic trip unit can include one or more of the following settings:

- long-time current pickup setting,
- long-time delay setting,
- short-time current pickup setting,
- short-time delay setting, and
- instantaneous current pickup setting (normally disabled).

Selective coordination among electronic trip breakers is achieved by appropriately adjusting the trip settings of the electronic trip units (see Figure 2).

Figure 2 – Trip Settings

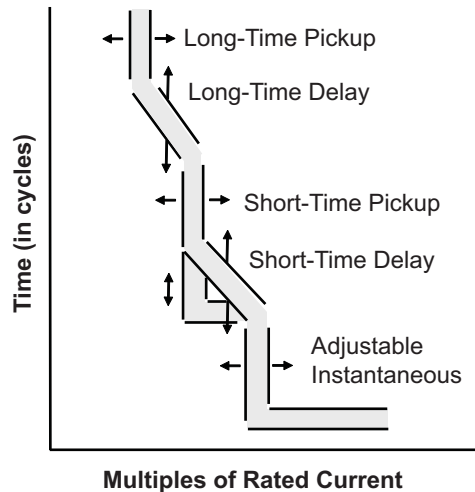

Engineering studies for selective coordination and arc flash hazards are completed to ensure minimum disruption to available power through the electrical distribution system and, if a detected fault were to happen, to minimize the available incident energy.

These studies often guide decisions to maintain electrical coordination and availability of electrical power through the addition of time-delay settings to the electronic trip unit. The most common is the short time-delay setting, which is used to ensure selective coordination that allows an increased incident energy level in the event of an arcing fault. Methods can be incorporated into any electrical system design to minimize the available incident energy while maintaining coordination (either automatically or manually, as described below).

Automatic Reduction in Incident Selective Energy—Zone Interlocking (ZSI)

Micrologic electronic trip circuit breakers (see Figure 3 on page 3) can accommodate ZSI. In a ZSI system, the ZSI terminals from all downstream Micrologic circuit breakers are connected to the ZSI terminals of the upstream Micrologic circuit breaker, creating a protection zone that is formed from the load side of the upstream circuit breaker extending to the line side of the downstream circuit breakers.

Figure 3 – PowerPact™ P- and R-Frame Circuit Breakers with Micrologic Electronic Trip Units



NOTE: All Micrologic P- and H-trip units with the blue ERMS label are suitable for ERMS applications.

In a typical ZSI connection, wiring is run from the downstream ZSI OUT Signal terminal to the upstream ZSI IN Signal terminal and from the downstream ZSI OUT terminal to the upstream ZSI IN Short-time and/or ZSI IN ground-fault terminal. See Figure 4 for details.

Figure 4 – Typical ZSI Connections

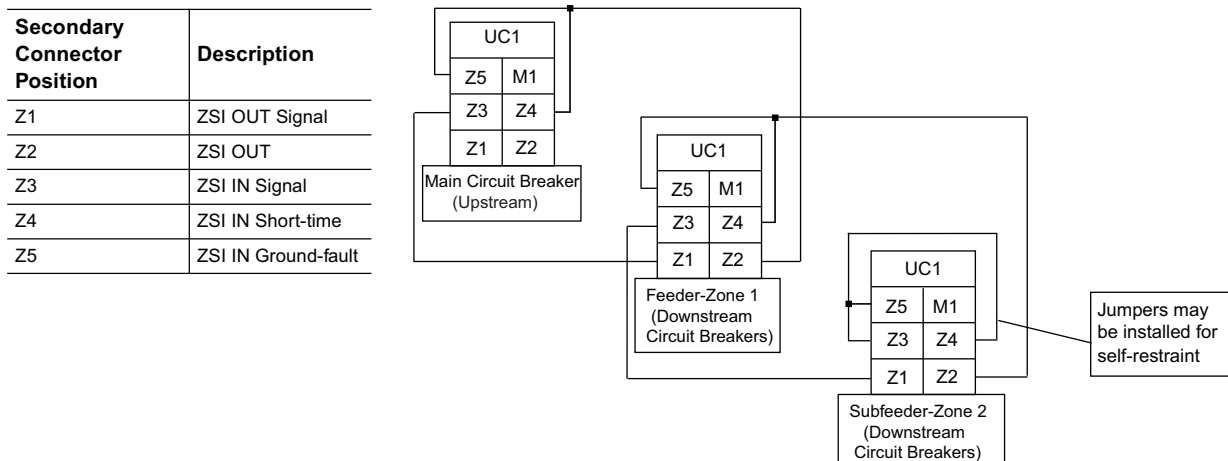

When a device equipped with ZSI senses a short circuit or ground fault, it sends a restraint signal (via the restraint wire) to the ZSI device just upstream from it. This activates the preset time delay on the upstream device.

When a device equipped with ZSI senses a short circuit or ground fault and **does not** receive a restraint signal, its preset time delay will not be activated and it will trip with no intentional delay.

Without ZSI, a coordinated system results in the circuit breaker closest to the fault clearing the fault, but usually with an intentional delay. With ZSI, the device closest to the fault will ignore its preset short-time and/or ground-fault delays and clear the fault with no intentional delay.

Manual Reduction in Incident Energy—ERMS Switch

Figure 5 – Local ERMS Switch



The ERMS switch (see Figure 5) temporarily lowers the instantaneous pickup of the circuit breaker to a pre-programmed value and provides a circuit protection system with two modes: a normal mode and a maintenance mode (in which potential arc flash energy is reduced).

In normal mode, the upstream circuit breaker acts in accordance with the settings provided in the electronic trip unit that provides selective coordination of the electrical distribution system.

In maintenance mode, the upstream circuit breaker lowers its instantaneous pickup (default if not programmed = $2xI_n$), causing very fast tripping of the circuit breaker to clear the fault condition. By responding quickly to an arcing fault, incident energy is reduced. In fact, with proper use, selective coordination can still be preserved when ERMS is in maintenance mode.

Summary

The use of electronic trip circuit breakers as protective devices in electrical distribution systems provides the advanced ability to selectively coordinate and enhance safety. The ZSI system provides the ability to maintain electrical coordination and decrease the incident energy hazards. The ERMS switch provides a manual means that may be incorporated into a facility's Lock Out/Tag Out procedure, per NFPA 70E, reducing the level of Personal Protection Equipment required for the personnel working on or near the energized equipment.

To ensure the chosen settings allow for proper operation of the ZSI system or ERMS switch, an engineering analysis is required.

Related Documents

- Reducing Fault Stress with Zone-Selective Interlocking (Document No. 0600DB0001)
- Guide to Power System Selective Coordination 600 V and Below (Document No. 0100DB0603)
- Energy Reduction Maintenance Setting (ERMS) System Installation and User Guide (Document No. NHA67346)
- Arc Flash Reduction Systems—Are They Always a Good Idea? (Document No. 0600DB0901)

You can download these documents from our website at www.schneider-electric.com/us/en/download.