

**I/A Series<sup>®</sup> Magnetic Flow Transmitters  
Model IMT25**

**with**

**8000A Series Wafer Body Flowtubes and  
2800, 8300, 9100A, 9200A and 9300A Series Flanged Flowtubes**

**Installation**



# Contents

Figures .....	5
Tables .....	7
<b>Important Information .....</b>	<b>9</b>
Please Note .....	9
<b>1. Introduction .....</b>	<b>11</b>
Overview.....	11
Reference Documents .....	11
General Description .....	12
Standard Specifications.....	13
Electrical Safety Specifications.....	14
Electromagnetic Compatibility (EMC) Specifications .....	15
Transmitter Identification.....	15
Unpacking and Handling Procedure .....	17
Setting Hardware Switches .....	17
Internal/External Power for Current and Pulse Outputs .....	17
Write Protect Switch.....	18
<b>2. Transmitter Mounting Procedures.....</b>	<b>21</b>
Transmitter Dimensions.....	21
Orientation of Transmitter Front Panel .....	21
Orientation of Integral Transmitter/Flowtube Assembly.....	21
Remotely Mounting the Transmitter to a Surface .....	23
Mounting the Transmitter to a DN50 or 2-in Pipe .....	25
<b>3. Wire Entrances and Conduit Connections.....</b>	<b>27</b>
Transmitter Mounted to Flowtube .....	27
Transmitter Mounted in a Remote Location.....	28
Optional Cable Glands for Nonconduit Applications.....	29
<b>4. Wiring a Remotely Mounted Transmitter to a Flowtube .....</b>	<b>31</b>
Transmitter Signal Cable Requirements.....	31
Flowtube Coil Wire Requirements .....	31
Signal Cable Preparation - Transmitter End.....	31

Signal Cable Preparation - Flowtube End .....	33
Signal Cable Wires, Coil Drive Wires, and Terminal Block Designations .....	34
Wiring the Transmitter to a 2800 or 8300 Flowtube .....	37
Wiring the Transmitter to an 8000A, 9100A, 9200A, or 9300A Flowtube .....	38
<b>5. Transmitter I/O Wiring.....</b>	<b>41</b>
Accessing Transmitter Wire Terminals .....	41
Wiring the Digital Output Circuit .....	42
Current Output and Pulse Output Wiring.....	43
Contact Input/Output Wiring .....	47
Foundation Fieldbus Output Wiring.....	48
Transmitter Mains (Power) Wiring.....	49
<b>6. Installing Fieldbus Software.....</b>	<b>51</b>

# Figures

1	Typical Transmitter Data and Certification Plates.....	16
2	Accessing Internal/External Power Switches.....	18
3	Power Switch Settings.....	18
4	Write Protection Switch .....	19
5	Orientation of Transmitter and Flowtube .....	22
6	Mounting Transmitter to a Surface.....	24
7	Mounting the Transmitter to a DN50 or 2-in Pipe .....	25
8	Wire Entrances and Conduit Connections on Transmitters Mounted to Flowtubes .....	27
9	Wire Entrances and Conduit Connections on Transmitters Mounted in a Remote Location.....	28
10	Optional Cable Glands for Use in Nonconduit Installations .....	29
11	Optional Cable Gland Plug for Use in Nonconduit Installations.....	29
12	Cable Preparation.....	31
13	Twisted Pair Cable Preparation.....	32
14	Cable Preparation.....	33
15	Wiring of IMT25 Transmitter Single Compartment Enclosure .....	35
16	Wiring of IMT25 Transmitter Dual Compartment Enclosure (See Figures 12 and 13 for Wire Lead Preparation).....	36
17	Wiring of 8300 Series Flowtubes.....	37
18	Wiring of 2800 Series Flowtubes.....	38
19	Wiring of 8000A and 9300A Series Flowtubes .....	39
20	Wiring of 9100A and 9200A Series Flowtubes .....	40
21	Accessing Transmitter Wire Terminals .....	41
22	Typical Digital Output Signal to an I/A Series System, HART Communicator, and PC-based Configurator .....	42
23	Location of Current Output and Pulse Output Terminals .....	43
24	Supply Voltage and Loop Load Requirements for Externally Powered Current Output Circuits.....	44
25	Current Output Wiring - Internal Power.....	45
26	Current Output Wiring - External Power.....	45
27	Pulse Output Wiring - Internal Power.....	46
28	Pulse Output Wiring - External Power .....	46
29	Contact Input Wiring .....	47
30	Contact Output Wiring .....	48
31	Fieldbus Output Wiring.....	49
32	Mains (Power) Wiring.....	50



# Tables

1	Reference Documents .....	11
2	Operating Transportation and Storage Conditions .....	13
3	Electrical Safety Specifications .....	14
4	International and European Union Standards.....	15
5	Process Fluid Conductivity and Cabling.....	31
6	Signal Cable Wires, Coil Drive Wires, and Terminal Block Designations .....	34
7	Load Resistance Range to Maintain Low State Voltage = 1 Volt max. ....	46





# Important Information

Read these instructions carefully and look at the equipment to become familiar with the device before trying to install, operate, service, or maintain it. The following special messages may appear throughout this manual or on the equipment to warn of potential hazards or to call attention to information that clarifies or simplifies a procedure.



The addition of either symbol to a “Danger” or “Warning” safety label indicates that an electrical hazard exists which will result in personal injury if the instructions are not followed.



This is the safety alert symbol. It is used to alert you to potential personal injury hazards. Obey all safety messages that follow this symbol to avoid possible injury or death.

## **DANGER**

**DANGER** indicates a hazardous situation which, if not avoided, **will result in death or serious injury**.

## **WARNING**

**WARNING** indicates a hazardous situation which, if not avoided, **could result in death or serious injury**.

## **CAUTION**

**CAUTION** indicates a hazardous situation which, if not avoided, **could result in minor or moderate injury**.

## **NOTICE**

**NOTICE** is used to address practices not related to physical injury.

## Please Note

Electrical equipment should be installed, operated, and maintained only by qualified personnel. No responsibility is assumed by Schneider Electric for any consequences arising out of the use of this material.

A qualified person is one who has skills and knowledge related to the construction, installation, and operation of electrical equipment and has received safety training to recognize and avoid the hazards involved.



# 1. Introduction

## Overview

The IMT25 Intelligent Magnetic Flow Transmitters, together with the 8000A Series Wafer Body or 2800, 8300, 9100A, 9200A, and 9300A Series Flanged Magnetic Flowtubes, combine to form the I/A Series Magnetic Flowmeters with pulsed dc excitation. The flowmeter is a microprocessor-based magnetic flow system for use with most conductive fluids from the most common to the very difficult-to-handle conductive fluids. The transmitter converts the low level, high impedance signal from lined flowtubes to a digital, current, or pulse output proportional to flow rate. For flowtube specifications, refer to the applicable documents listed in Table 1.

The IMT25L is a low price version of the IMT25 Magnetic Flow Transmitter. Some options and features of the IMT25 are **not** available in the IMT25L.

## Reference Documents

*Table 1. Reference Documents*

Document	Document Description
DP 021-365	IMT25 I/A Series Magnetic Flow Transmitter - Dimensions
DP 021-366	IMT25L I/A Series Magnetic Flow Transmitter - Dimensions
MI 020-360	Wiring Guidelines for FOUNDATION fieldbus Transmitters
MI 020-495	PC20 Intelligent Field Device Configurator
MI 020-504	PC50 Intelligent Device Tool - Operation Using FoxCom Protocol
MI 020-505	PC50 Intelligent Device Tool - Operation Using HART Protocol
MI 021-120	2800 Series Flowtubes (1/10 to 12 in)
MI 021-137	2800 Series Flowtubes (14 to 36 in) - Installation
MI 021-141	2800 Series Sanitary Flowtubes (1/2 to 3 in) - Installation
MI 021-380	8000A Series Wafer Body Flowtubes - Installation
MI 021-381	8300 Series Flanged Flowtubes - Installation
MI 021-386	9300A Series Flanged Flowtubes - Installation
MI 021-390	IMT25 Magnetic Flow Transmitter - Operation, Configuration, and Calibration
MI 021-391	IMT25 Magnetic Flow Transmitter - System Maintenance
MI 021-397	IMT25 Transmitter - Operation Using a HART Communicator
MI 021-399	IMT25 Transmitter - Operation from a Fieldbus Host
MI 021-413	9100A and 9200A Series Flanged Magnetic Flowtubes - Installation
PL 008-745	IMT25 Magnetic Flow Transmitter - Parts List
PL 008-746	IMT25L Magnetic Flow Transmitter - Parts List
TI 27-71f	Magnetic Flowtubes, Material Selection Guide
TI 027-072	Electrical Conductivity of Process Liquids
B0400FD	FOUNDATION fieldbus High Interface (FBM 220/221)
<b>FOUNDATION Fieldbus Documents:</b>	
FD-043 Rev.2.0	Technical Overview — FOUNDATION Fieldbus
AG-140 Rev. 1.0	Application Guide — Wiring and Installation, 31.25 kbits/s, Voltage Mode, Wire Medium
AG-163 Rev. 1.0	Application Guide — FOUNDATION Fieldbus Intrinsically Safe Systems

## General Description

The IMT25 Intelligent Magnetic Flow Transmitter is used with the 8000A Series Wafer Body Flowtubes or the 2800, 8300, 9100A, 9200A, or 9300A Series Flanged Body Flowtubes. It can either be remotely mounted to a surface (IMT25-S), remotely mounted to a pipe (IMT25-P), or mounted directly onto an 8000A or 9300A flowtube (IMT25-I).

The transmitter uses a pulsed-dc technique to energize the flux-producing coils of the flowtube. As the process liquid passes through the magnetic field in the flowtube, low-level voltage pulses are developed across a pair of electrodes. The voltage level of these pulses is directly proportional to the average velocity of the liquid. The transmitter converts the voltage pulses to a digital and a standard 4 to 20 mA output signal.

The transmitter is available with three communication protocols.

One is a FoxCom communications protocol. The digital output signal in this version is used for flowmeters serving as a primary measuring device in an I/A Series system. You can communicate with this version via the I/A Series system, the PC-based Configurator, or the optional local keypad/display.

Another has HART communications capability. You can communicate with this version via a HART Communicator, PC-Based Configurator, or the optional local keypad/display. The 4 to 20 mA output signal in both of these versions is used with a suitable receiver to indicate, record, and/or control a variable. The signals are simultaneously available at a common pair of output terminals.

The third has FOUNDATION fieldbus communication capability. You can communicate with this version via a fieldbus host or the optional local keypad/display.

A pulse output is also available. The pulse output signal can be configured as a scaled pulse for totalization or frequency for flow rate output. Details of the output signals are given in the “Standard Specifications” on page 13.

The keypad/display option consists of a 32-alphanumeric character, 2-line back-lighted LCD display and a 5-button keypad. The display can indicate positive total, negative total, net total, net inventory, and flow rate in conventional flow units. A “+” or “-” indicator shows flow direction. This option allows the transmitter to be used as a stand-alone unit and gives you complete operation and configuration capabilities.

The optional clear plastic guard helps protect the display and keypad during washdown operations to help prevent inadvertent activation of the buttons by the washdown stream. However, the front panel is protected to NEMA 4X even without the guard.

The optional I/O access port is a circular recess in the front face of the instrument protected by a separate cover integrally connected to the front panel to help prevent loss or misplacement. You can access the port by loosening a screw on the port cover. Inside the access port are two banana plug sockets. These sockets allow direct connection to the PC-based Configurator, a HART Communicator or a Fieldbus host. The I/O access port option permits access to terminals without opening the transmitter housing cover.

This instruction contains transmitter installation details. Refer to “Reference Documents” on page 11 for a list of instructions for flowmeter maintenance, configuration, operation, calibration, and other details.

# Standard Specifications

*Table 2. Operating Transportation and Storage Conditions*

Transmitter Influence	Reference Operating Conditions	Normal Operating Condition Limits	Operative Limits	Transportation and Storage Limits
Ambient Temp. Without LCD Indicator (a)	23±2°C (73±3°F)	-20 and +55°C (-4 and +131 °F)	-30 and +70°C (-22 and +158°F)	-40 and +85°C (-40 and +185 °F)
With LCD Indicator (a)	23±2°C (73±3°F)	-20 and +55°C (-4 and +131 °F)	-20 and +70 °C (-4 and +158 °F)	-30 and +80 °C (-22 and +176 °F)
Process Temperature (a)	23±2°C (73±3°F)	See Note (a)	See Note (a)	Not Applicable
Relative Humidity	50±10%	5 and 100% (b)	5 and 100% (b)	0 and 100% (b)
Supply Voltage ac Voltage dc Voltage	120 or 240 V ac 24 V dc, 1.5 A	85 and 264 V ac Rated Voltage ±20%	85 and 264 V ac Rated Voltage ±20%	Not Applicable
Supply Frequency, Digital Output	50 or 60 Hz	Rated Frequency ±3 Hz	47 and 63 Hz	Not Applicable
4 to 20 mA Output Supply Voltage External Load	24 V dc 300 Ω	(Refer to Figure 24) 10 and 50 V dc 0 and 1950 Ω	(Refer to Figure 24) 10 and 50 V dc 0 and 1950 Ω	Not Applicable
Pulse Output Supply Voltage External Load	24 V dc 480 Ω	5 and 42 V dc 1 - 80 mA	5 and 42 V dc 1 - 80 mA	Not Applicable
Vibration	Negligible	0 and 5 m/s <sup>2</sup> (0 and 0.5 g) from 5 to 500 Hz	5 m/s <sup>2</sup> (0.5 g) up to 500 Hz	Normal Handling and Shipping Conditions

a. Except for integrally mounted transmitters, there are no process temperature restrictions beyond those imposed by the flowtube specifications. For integrally mounted transmitters, the ambient limit of the transmitter, 70°C (158°F), must not be exceeded and the process temperature must not exceed 121°C (250°F).

b. Relative humidity limits apply only with transmitter covers properly installed.

# Electrical Safety Specifications

**— NOTE —**

The transmitter has been designed to meet the electrical safety descriptions listed in Table 3 below. For detailed information or status of testing laboratory approvals or certifications, contact Global Customer Support.

Refer to Table 3 for electrical classification, application conditions, and electrical safety design code. The single-character electrical safety design code is included in the Model Number listed on the transmitter data plate.

*Table 3. Electrical Safety Specifications*

Testing Laboratory, Types of Protection, and Area Classification	Application Conditions	Electrical Safety Design Code (a)
<b>CSA</b> Class I, Division 2, Groups A, B, C, D; Class II, Division 2, Groups F, G; Class III, Division 2 Hazardous Locations.	Temperature Class T4 at maximum ambient of 70°C (158°F).	L
<b>FM</b> Ordinary Locations.	—	M
<b>FM</b> nonincendive, Class I, Division 2, Groups A, B, C, D; Class II, Division 2, Groups F, G; Class III, Division 2 Hazardous Locations.	Temperature Class T4 at maximum ambient of 70°C (158°F).	N
No certification required.	—	Z

a. The single-character electrical safety design code is printed on the data plate as part of the model code. The location of the code within the model number is shown below:

IMT25-PEADB10K



Electrical Design Safety Code

# Electromagnetic Compatibility (EMC) Specifications

The IMT25 Transmitter complies with international and European Union standards listed in Table 4.

*Table 4. International and European Union Standards*

Parameter	IEC Standard	EN Standard
Radiated RFI Immunity	10 V per IEC 61000-4-3	10 V per EN 61000-4-3
Conducted RFI Immunity	10 V per IEC 61000-4-6	10 V per EN 61000-4-6
RFI Radiated and Conducted Emissions	CISPR Class A	EN 55011 Class A
ESD Immunity	6 kV contact discharge per IEC 61000-4-2	6 kV contact discharge per IEC 61000-4-2
Electrical Fast Transients/Burst Immunity	2 kV per IEC 61000-4-4	2 kV per EN 61000-4-4
Shock Wave Immunity	4 kV per IEC 61000-4-5	4 kV per EN 61000-4-5
Power Dips and Interruptions	IEC 61000-4-11	EN 61000-4-11

## Transmitter Identification

The transmitter can be identified by the data plate located on its left side surface. A typical data plate is shown in Figure 1. In addition to the transmitter data plate, a certification agency plate is also located on the same surface. Refer to the applicable flowtube instructions for information regarding flowtube-specific data plates.

Figure 1. Typical Transmitter Data and Certification Plates

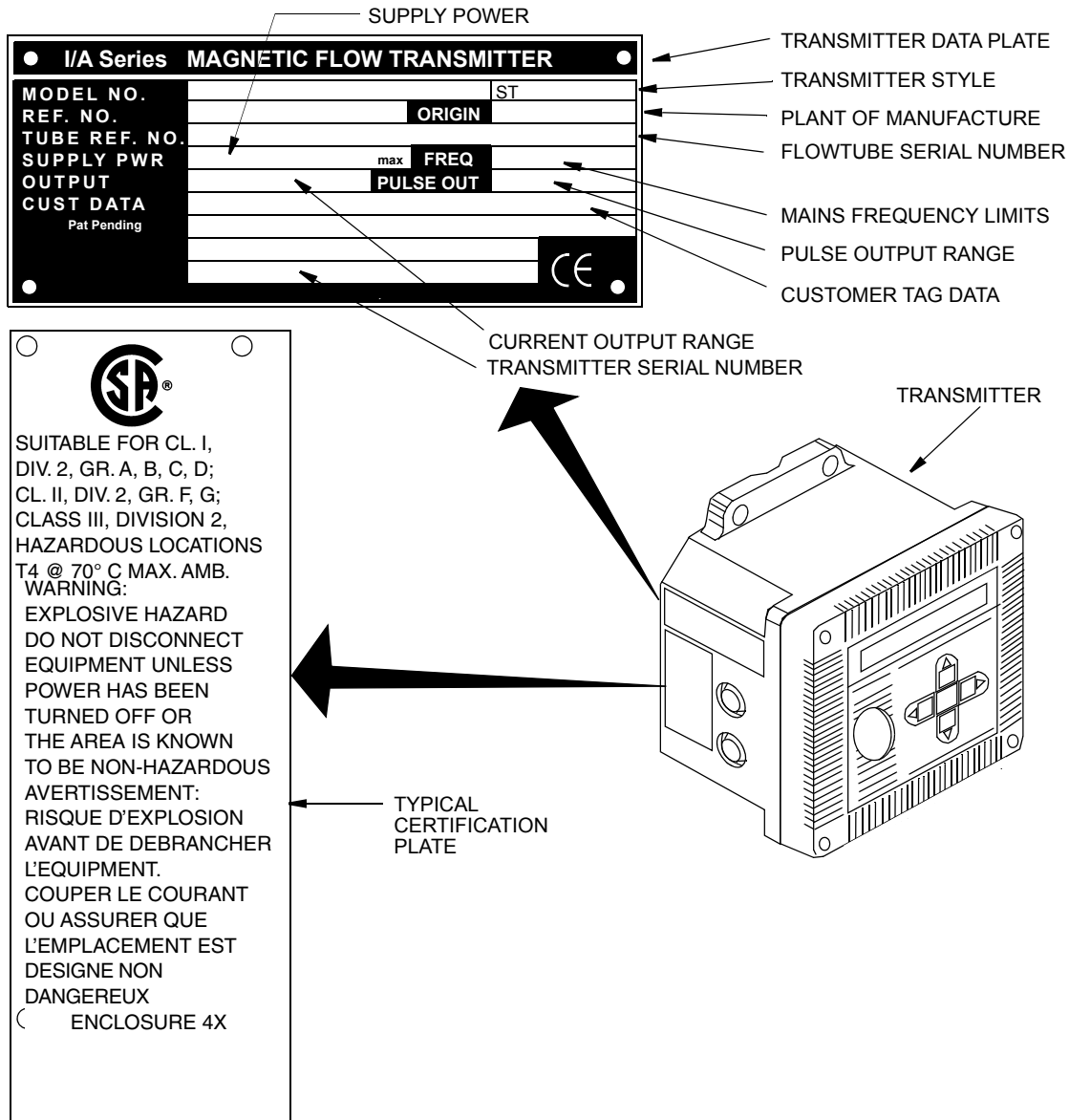

**NOTE**

Internal or external power of current and pulse output is set at the factory as shown on your data plate. This can be changed by switches in your transmitter. For details, refer to "Setting Hardware Switches" on page 17.



## Unpacking and Handling Procedure

After removing the transmitter from its shipping carton, inspect it for visible damage. If any damage is observed, notify the carrier immediately and request an inspection report. Obtain a signed copy of the report from the carrier.

### **NOTICE**

#### **POTENTIAL CONTAMINATION OF ELECTRODES AND EQUIPMENT DAMAGE**

For flowtube-mounted transmitters, avoid touching the flowtube electrodes with your fingers or any material that can contaminate the electrodes. A deposit on the electrodes results in a high-impedance boundary between the electrodes and conductive fluid. If the electrodes have been touched, clean them with isopropyl alcohol. Also, as stated above, notify carrier if any damage is observed and obtain a signed copy of an inspection report.

**Failure to follow these instructions can result in contamination of electrodes and equipment damage.**

For detailed information regarding flowtube handling, refer to the applicable flowtube instruction.

## Setting Hardware Switches

### — NOTE —

1. Current output is not available on IMT25-...F Transmitters.
2. Current Output on IMT25L Transmitters is external power only.

## Internal/External Power for Current and Pulse Outputs

Internal or external power for the transmitter output signals is switch selectable. The switches have been factory set as defined by the model code of the transmitter but the setting can be changed. There is a group of eight switches that control internal or external power. The four on the left set the current and digital loop power. The four on the right control the pulse loop output power.

### *Accessing the Switches*

These switches are accessed by removing the cover from the front of your transmitter. The cover attaches to the enclosure with four captive screws. See page 41 for cover fastener tightening specifications when replacing the cover.

*Figure 2. Accessing Internal/External Power Switches*

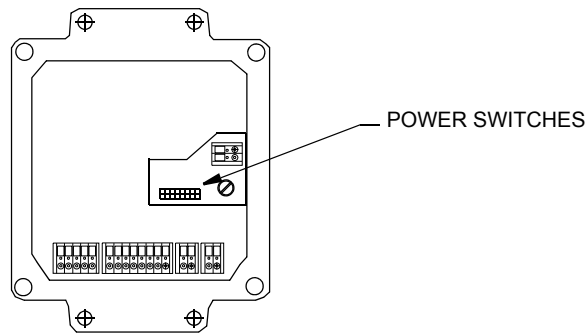

### Switch Settings

<b>⚠ WARNING</b>
<b>POTENTIAL EQUIPMENT DAMAGE</b>
The unit must be turned off to make changes to the switch settings.
<b>Failure to follow this instruction may result in equipment damage.</b>

For internal power (loop powered by this transmitter) toggle the switch to the position shown as black in Figure 3. For external power (loop power source external to this transmitter) toggle the switch to the position shown as white in Figure 3.

*Figure 3. Power Switch Settings*

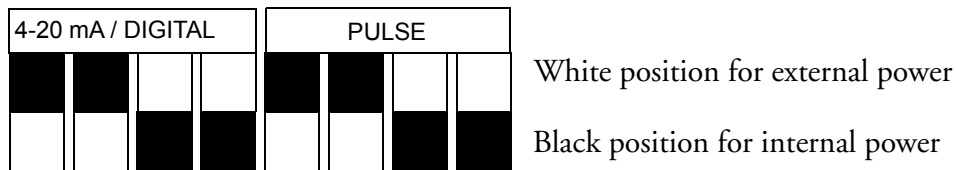

### Write Protect Switch

The write protection switch, located on the printed wiring board attached to the transmitter cover, allows or helps prevent anyone from changing the configuration of the transmitter or resetting the totalizer. This feature is usually used in custody transfer applications or when, for any other reason, you want to verify that the configuration and or totals are not changed. Therefore, the switch is usually placed in the “disable” position (factory default position). Placing the switch in the “enable” position, engages the protection.

---

**NOTE**

---

A change in the write protect switch position does not take effect until power is turned off and on again.

---

<b>⚠ CAUTION</b>
<b>EQUIPMENT OPERATION HAZARD</b>
Do not touch the service switch. It is for use by service personnel only. The transmitter does not operate correctly if this switch is in the enable position. If this switch has been moved to the enable position, return it to the disable position and turn power off and on.
<b>Failure to follow these instructions can result in injury or equipment damage.</b>

*Figure 4. Write Protection Switch*

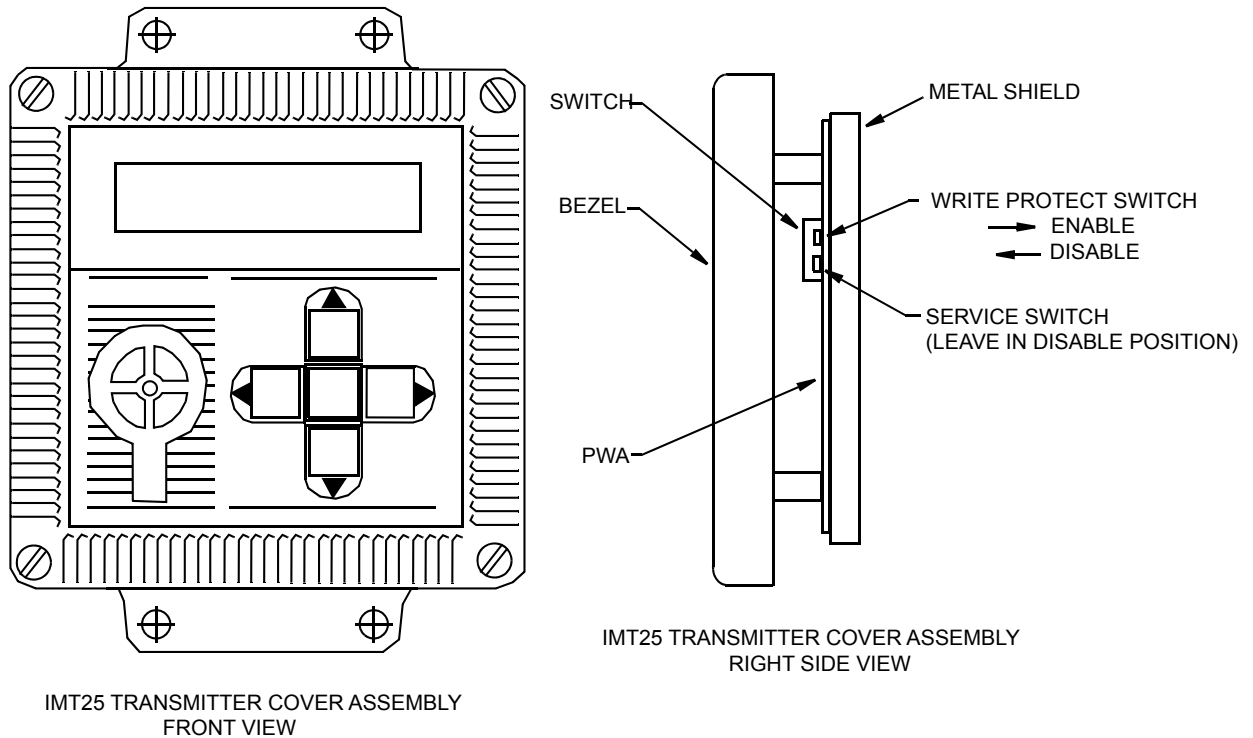



# 2. Transmitter Mounting Procedures

## Transmitter Dimensions

For IMT25 transmitter dimensions, refer to DP 021-365.

For IMT25L transmitter dimensions, refer to DP 021-366.

## Orientation of Transmitter Front Panel

The front panel assembly is integral with the front cover. A four hole, square pattern on the cover assembly allows it to be rotated in 90° increments to any desired position on the transmitter enclosure. Four captive screws attach the cover to the enclosure.

<b>▲ CAUTION</b>
------------------

<b>POTENTIAL EQUIPMENT DAMAGE</b>
-----------------------------------

The unit cannot be installed with the transmitter facing up. Water can pool on top of the unit.
---

<b>Failure to follow this instruction can result in equipment damage.</b>
---

## Orientation of Integral Transmitter/Flowtube Assembly

If an integrally mounted flowmeter/transmitter is specified, the transmitter and flowtube are assembled at the factory and shipped as a unit. The front face of the transmitter is parallel to the centerline of the flowtube and the flow direction arrow points to the right, as shown in Figure 5. Since the transmitter is already mounted to the flowtube, refer to the applicable flowtube installation instruction manual for installing the flowtube into the pipeline.

Before wiring the transmitter, you can rotate it 90° in either direction (not recommended with 3 inch and smaller Model 8000A Flowtubes). To do this, first remove the front cover, then remove the 1/2 NPS mounting nut, rotate the transmitter housing relative to the flowtube, and reinstall the mounting nut. Re-tighten the mounting nut to a torque of 81 N-m (60 lb-ft).

If none of the three positions is satisfactory, rotate the entire assembly 180° relative to the pipeline. If the direction of fluid flow in the pipeline does not agree with the arrow on the flowtube, reverse the polarity of the transmitter output signal by interchanging connections of the coil leads at the transmitter. If you prefer not to interchange the coil leads, you can connect them in the normal manner and, instead, reverse polarity of the transmitter output signal by changing the configuration of the transmitter. For specific instructions on how to change the configuration, refer to the applicable reference document in Table 1.

Figure 5. Orientation of Transmitter and Flowtube

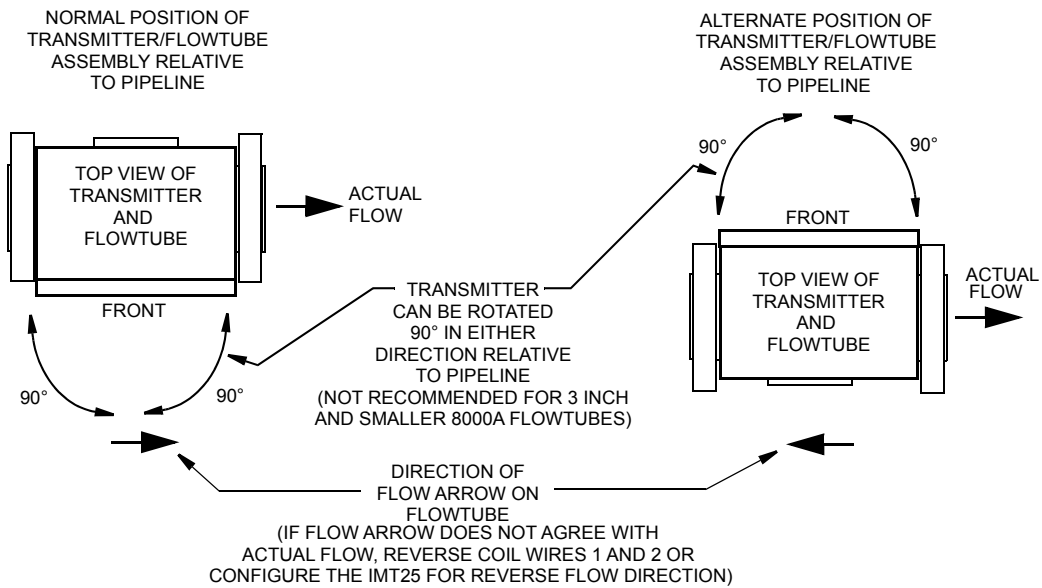
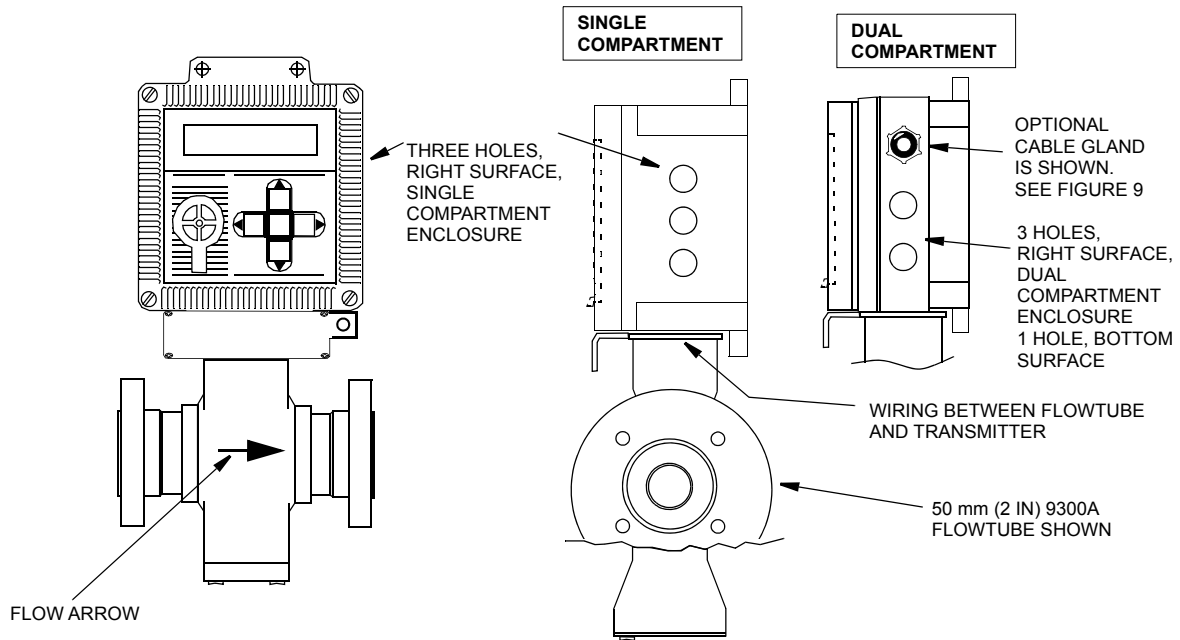

## Remotely Mounting the Transmitter to a Surface

The transmitter can be mounted against a surface as shown in Figure 6. In selecting the transmitter orientation, consider the locations of openings for conduits or cable glands on the bottom and side surfaces of the transmitter.

As stated previously, the transmitter cover can be turned in 90° increments. This permits the transmitter display and keypad to be turned so they can be easily read and used.

1. Select the desired transmitter orientation and position the cover on the transmitter as described in preceding paragraphs.
2. Turn the transmitter to the desired orientation against the surface; mount it to the surface using the four mounting holes in the enclosure mounting flanges and the required mounting hardware (supplied by user).
3. For transmitter wiring details, refer to “Wiring” sections.

---

**NOTE**

---

If you want to convert from surface mounting to pipe mounting of the transmitter, it can provide parts to implement this conversion. Refer to PL 008-745 (IMT25) or PL 008-746 (IMT25L) for the applicable parts and part numbers required.

---

**Figure 6. Mounting Transmitter to a Surface**

NOTE: FOR DIMENSIONAL INFORMATION, REFER TO DP 021-365 (IMT25) OR DP 021-366 (IMT25L)

TRANSMITTER CAN BE MOUNTED WITH FLANGES TOP AND BOTTOM OR LEFT AND RIGHT, DEPENDING ON WIRING ORIENTATION REQUIRED

**SINGLE COMPARTMENT ENCLOSURE**

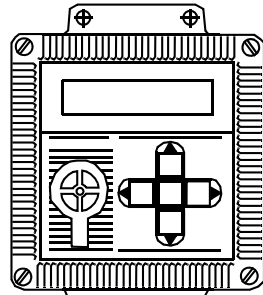

SQUARE HOLE PATTERN ALLOWS 90° ROTATION OF COVER. CAPTIVE SCREWS ARE USED

8.4 mm (0.33in) DIAMETER HOLES, FOUR PLACES, ON FLANGES FOR SURFACE AND PIPE MOUNTING

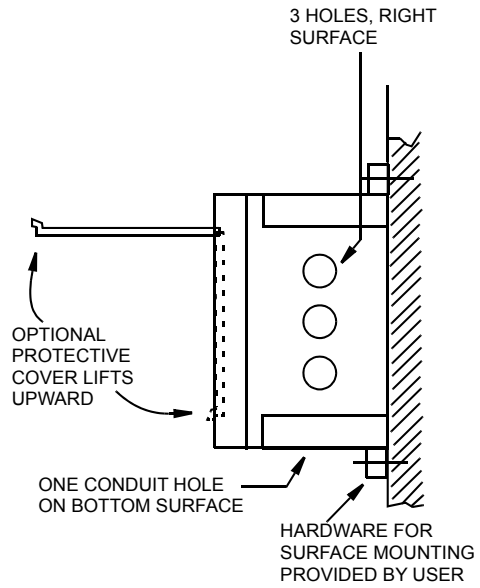

**DUAL COMPARTMENT ENCLOSURE**

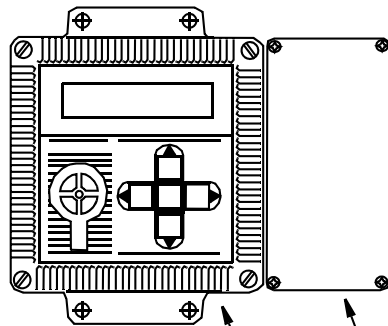

ELECTRONICS COMPARTMENT

THREE HOLES, RIGHT SURFACE

OPTIONAL FIELD TERMINALS COMPARTMENT

SURFACE MOUNTING

ONE HOLE, BOTTOM SURFACE



## Mounting the Transmitter to a DN50 or 2-in Pipe

The transmitter can be mounted to a horizontal or vertical DN50 or 2-in pipe as shown in Figure 7.

Transmitter covers can also be turned in 90° increments by unscrewing four screws, as previously described. This permits the optional transmitter display and keypad to be turned so they can be easily read.

1. Select the desired transmitter orientation and position the cover on the transmitter as described in preceding paragraphs.
2. Gather the U-bolts, flat washers, lockwashers, and nuts provided (with the pipe mounting kit) and keep them in a convenient place in preparation for use during installation.
3. Hold and press the transmitter against the pipe while installing one U-bolt onto the pipe and into the transmitter mounting flange.
4. Add the plain washer and lockwasher, and nuts, and then hand-tighten the two nuts.
5. Repeat Steps 3 and 4 for the second U-bolt and then tighten all nuts securely.
6. For transmitter wiring details, refer to “Wiring” sections.

*Figure 7. Mounting the Transmitter to a DN50 or 2-in Pipe*

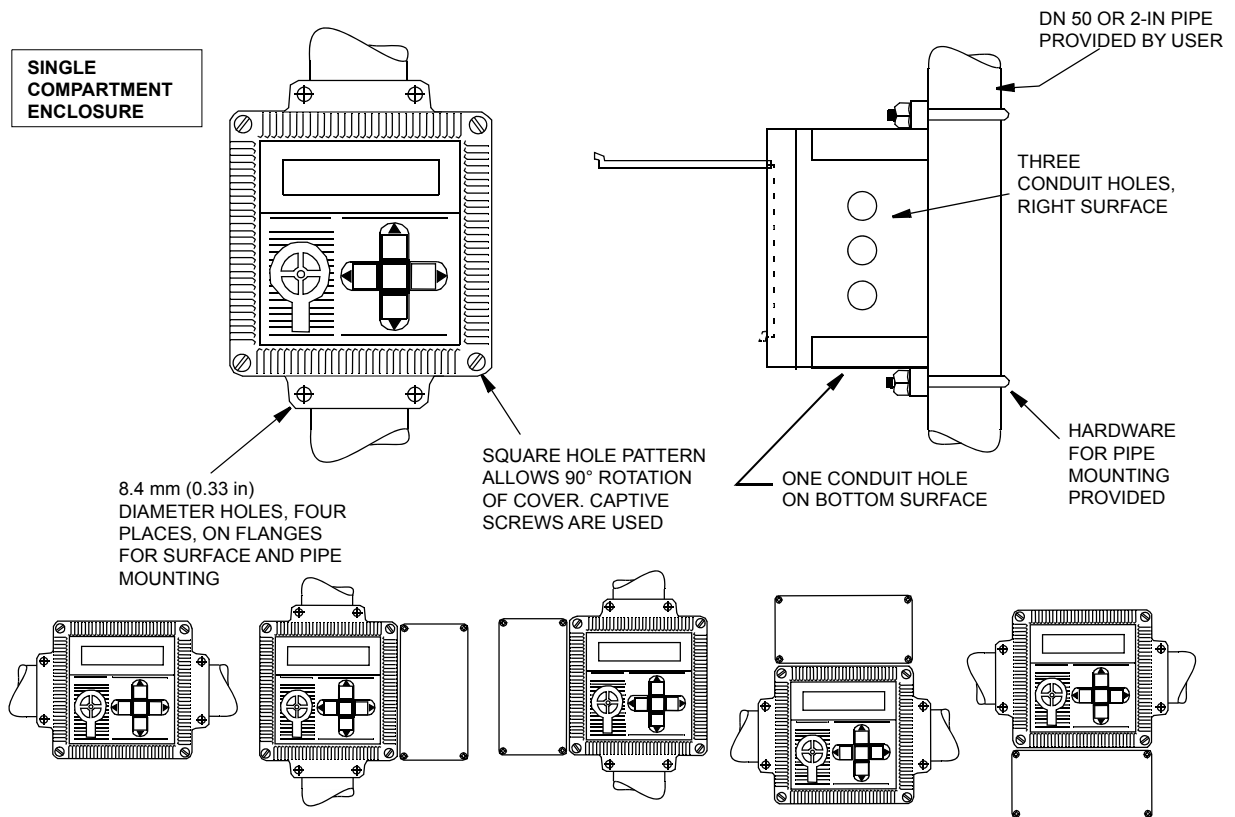



# 3. Wire Entrances and Conduit Connections

## Transmitter Mounted to Flowtube

Wire entrances to the flowtube-mounted transmitter are provided by 22 mm (0.866 in) diameter holes on the side surfaces of the single or dual compartment enclosure. See Figure 8. Optional cable glands are offered for use with cables having thicknesses between 7 and 12 mm (0.27 and 0.48 in) as shown in Figure 10, and are recommended in nonconduit installations.

*Figure 8. Wire Entrances and Conduit Connections on Transmitters Mounted to Flowtubes*

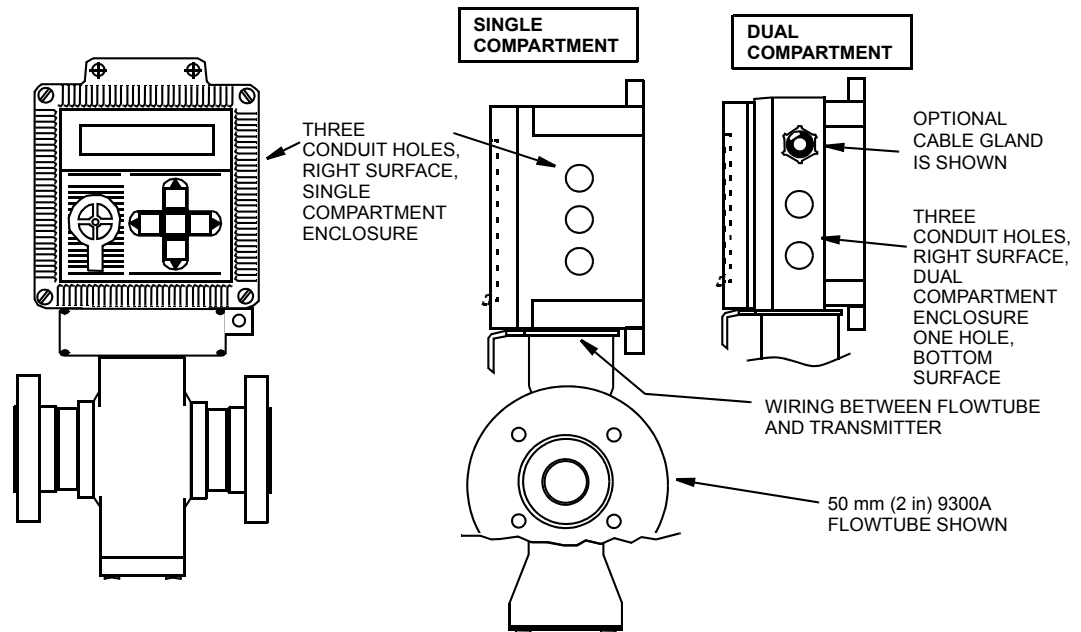

**NOTES:**

1. KNOCKOUTS MUST BE REMOVED AT THE FACTORY PER SALES ORDER.
2. THE CONDUIT HOLES ARE 22 mm (0.866 in) DIAMETER. THE KNOCKOUTS, WHEN REMOVED, ALSO PROVIDE THE SAME SIZE HOLES.
3. THE HOLES ARE SIZED TO ACCOMMODATE PG 13.5 OR 1/2 NPT CONDUIT CONNECTORS PROVIDED BY USER. OPTIONAL CABLE GLANDS ARE ALSO OFFERED FOR FIELD WIRING. (SEE FIGURE 10).
4. TO MAINTAIN NEMA 4X MOISTURE, DUST, AND CORROSION PROTECTION, USE APPROVED WATER TIGHT CONDUIT FITTINGS AND PLUG ALL UNUSED HOLES WITH L0400BD OR EQUIVALENT, OR PLUG UNUSED CABLE GLANDS WITH OPTIONAL PLUG SHOWN IN FIGURE 11. (RED SHIPPING PLUGS DO NOT MEET NEMA 4X REQUIREMENTS.)
5. IF CONDUIT IS USED, SEPARATE RUNS ARE RECOMMENDED FOR AC SUPPLY AND OUTPUT SIGNALS.

## Transmitter Mounted in a Remote Location

Wire entrances to remotely-mounted transmitters are the same as for flowtube-mounted transmitters except that factory removable knockouts and holes are provided on the lower surface of the transmitter (see Figure 9).

*Figure 9. Wire Entrances and Conduit Connections on Transmitters Mounted in a Remote Location*

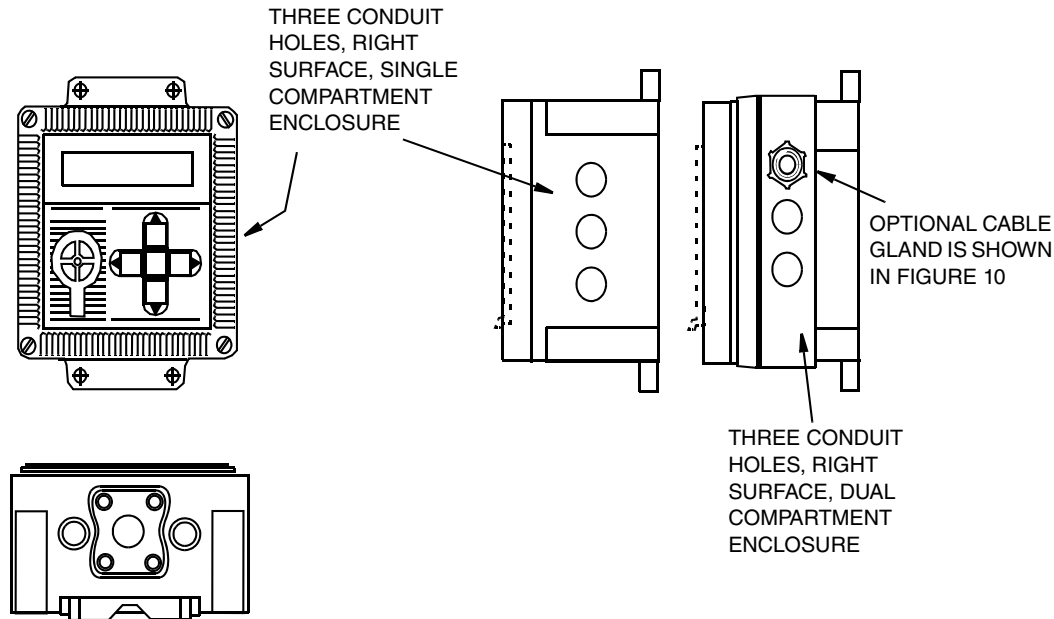

### NOTES:

1. KNOCKOUTS MUST BE REMOVED AT THE FACTORY PER SALES ORDER.
2. THE HOLES ARE 22 mm (0.866 in) DIAMETER. THE KNOCKOUTS, WHEN REMOVED, ALSO PROVIDE THE SAME SIZE CONDUIT HOLES.
3. THE HOLES ARE SIZED TO ACCOMMODATE PG 13.5 OR 1/2 NPT CONDUIT CONNECTORS PROVIDED BY USER. OPTIONAL CABLE GLANDS ARE ALSO OFFERED FOR FIELD WIRING. (SEE FIGURE 8).
4. TO MAINTAIN NEMA 4X MOISTURE, DUST, AND CORROSION PROTECTION, USE APPROVED WATER TIGHT CONDUIT FITTINGS AND PLUG ALL UNUSED HOLES WITH L0400BD OR EQUIVALENT, OR SEE FIGURE 9. (RED SHIPPING PLUGS DO NOT MEET NEMA 4X REQUIREMENTS.) WHEN USING L0400BD, PLUG MUST BE TORQUED TO 11-14 LB-IN FOR PROPER SEALING.
5. IF CONDUIT IS USED, SEPARATE RUNS ARE RECOMMENDED FOR INPUT SIGNAL, OUTPUT SIGNAL, AC SUPPLY, AND FLOWTUBE COIL DRIVE WIRES.

## Optional Cable Glands for Nonconduit Applications

Optional cable glands are used to provide a rain tight, strain relieved entrance for 7 to 12 mm (0.27 to 0.48 in) diameter cable. Body and seal nut are nylon; the compression gland is neoprene. See Figure 10 and Figure 11.

*Figure 10. Optional Cable Glands for Use in Nonconduit Installations*

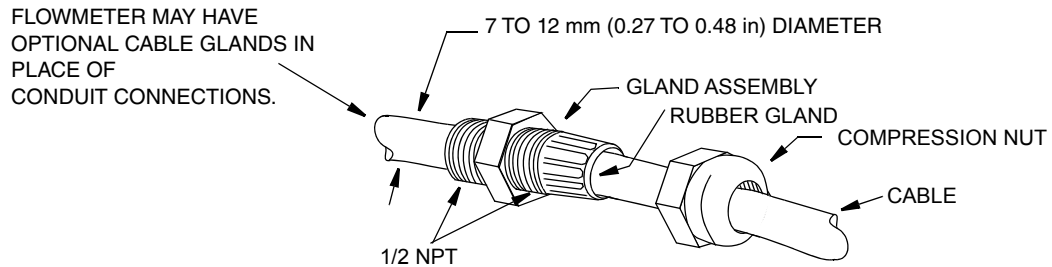

*Figure 11. Optional Cable Gland Plug for Use in Nonconduit Installations*

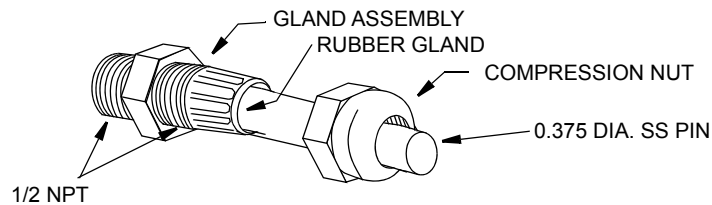



# 4. Wiring a Remotely Mounted Transmitter to a Flowtube

## Transmitter Signal Cable Requirements

Table 5. Process Fluid Conductivity and Cabling

Maximum Cable Length	Minimum Fluid Conductivity	Signal and Coil Drive Cables
300 m (1000 ft)	5 $\mu$ S/cm min.	Signal and coil drive cables in separate conduit. Signal cable must be Part No. R0101ZS (feet) or B4017TE (meters).
225 m (750 ft)	5 $\mu$ S/cm min.	Signal and coil drive cables in same conduit. Signal cable must be Part No. R0101ZS (feet) or B4017TE (meters).
150 m (500 ft)	20 $\mu$ S/cm min.	Signal cable can be in the same conduit as coil drive cable. Signal cable must be good quality twisted shielded pair, preferably no smaller than 1.0 mm <sup>2</sup> (or 18 AWG) for mechanical considerations (Belden 8760 or 9318, Alpha 5610/1801 or 5611/1801, or equivalent).

Values in table are fluid conductivity minimums, and maximum distance between transmitter and flowtube. Refer to TI 027-072 for conductivities of various process liquids.

## Flowtube Coil Wire Requirements

It is recommended that 2-core (2-conductor) or 3-core (3-conductor) 2.50 mm<sup>2</sup> (18 AWG minimum). 90°C (194°F) rated wire is adequate if the process temperature is below 150°C (302°F).

## Signal Cable Preparation - Transmitter End

Figure 12. Cable Preparation

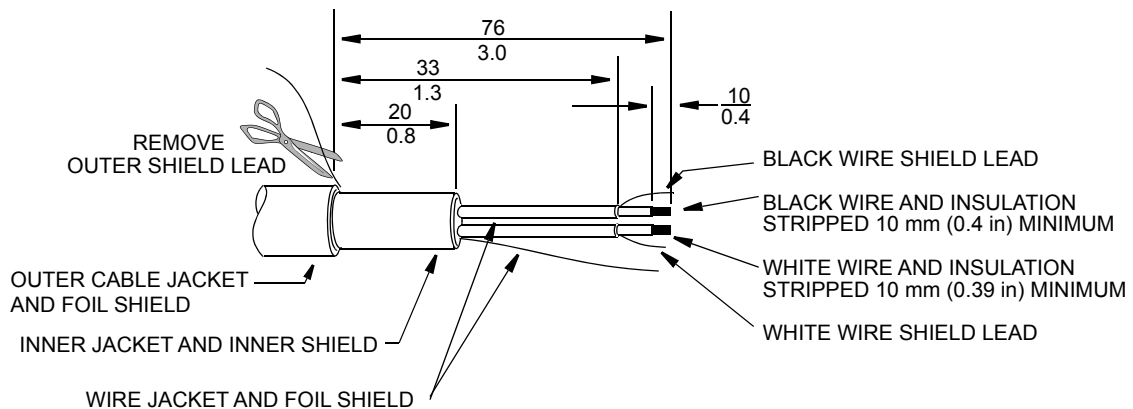

**Figure 13. Twisted Pair Cable Preparation**

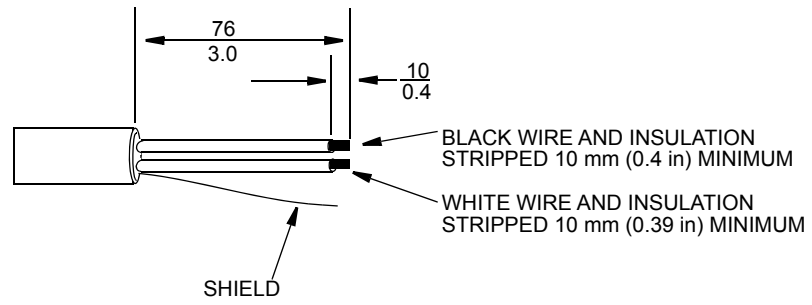



# Signal Cable Preparation - Flowtube End

*Figure 14. Cable Preparation*

**CABLE PREPARATION**

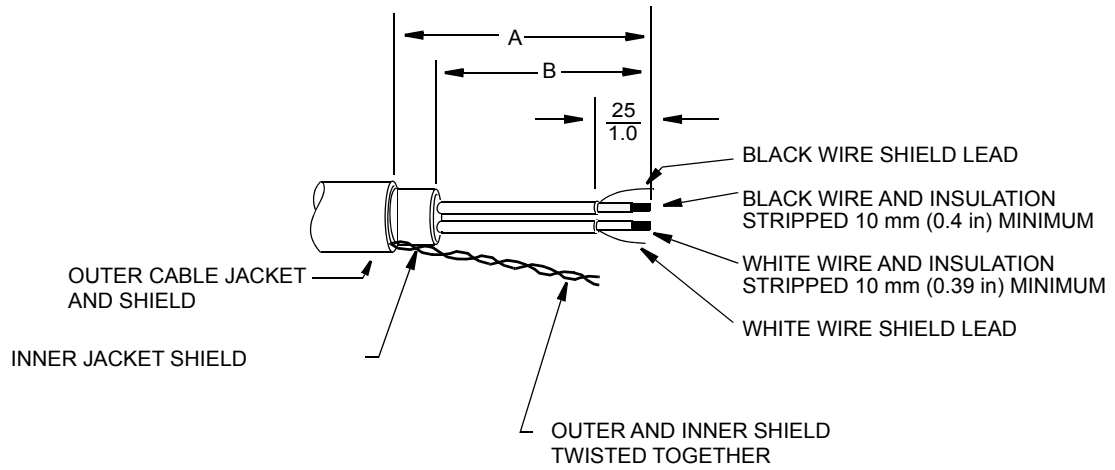

**TWISTED PAIR CABLE PREPARATION**

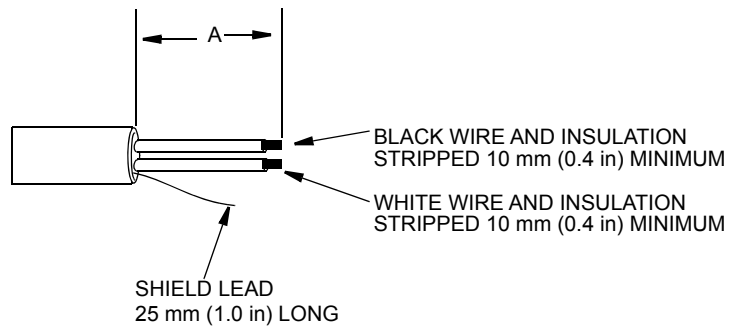

Dimension	Flowtube	
	2800/8300	8000A, 9100A, 9200A, 9300A
A	165 mm (6.5 in)	44 mm (1.7 in)
B (a)	162 mm (6.4 in)	41 mm (1.6 in)

a. Inner cable jacket may be cut back to outer cable jacket. Therefore, Dimension B can be equal to Dimension A.

# Signal Cable Wires, Coil Drive Wires, and Terminal Block Designations

Table 6 lists the signal cable and coil drive wire designations and the terminal block designations in the transmitter and applicable flowtube.

*Table 6. Signal Cable Wires, Coil Drive Wires, and Terminal Block Designations*

Flowtube Model	Flowtube Terminals (a)	Signal and Coil Drive Cable Description	Transmitter Terminals	Reference
8000A and 9300A	W SHW Gnd Screw SHB B	White Signal — W (b) (c) White Shield (d) — SH <sub>W</sub> (c) Solution Ground (d) — Inner Shield Lead (b) (c) Black Shield — SH <sub>B</sub> (c) Black Signal — B (b) (c)	SIGNAL W SIGNAL SH <sub>W</sub> SIGNAL SG SIGNAL SH <sub>B</sub> SIGNAL B	Figure 19
	1 2	Coil Drive Coil Drive	COIL 1 COIL 2	
8300 Flowtubes	W SH INNER SHLD SH B	White Signal — W (b) (c) White Shield (d) — SH <sub>W</sub> (c) Solution Ground (d) — Inner Shield Lead (b) (c) Black Shield — SH <sub>B</sub> (c) Black Signal — B (b) (c)	SIGNAL W SIGNAL SH <sub>W</sub> SIGNAL SG SIGNAL SH <sub>B</sub> SIGNAL B	Figure 17
	1 2	Coil Drive Coil Drive	COIL 1 COIL 2	
2800 Flowtubes	W SH INNER SHLD SH B	White Signal — W (b) (c) White Shield (d) — SH <sub>W</sub> (c) Solution Ground (d) — Inner Shield Lead (b) (c) Black Shield — SH <sub>B</sub> (c) Black Signal — B (b) (c)	SIGNAL W SIGNAL SH <sub>W</sub> SIGNAL SG SIGNAL SH <sub>B</sub> SIGNAL B	Figure 18
	2 1	Coil Drive (e) Coil Drive (e)	COIL 1 COIL 2	
9100A and 9200A	W SHW Gnd Screw SHB B	White Signal — W (b) (c) White Shield (d) — SH <sub>W</sub> (c) Solution Ground (d) — Inner Shield Lead (b) (c) Black Shield — SH <sub>B</sub> (c) Black Signal — B (b) (c)	SIGNAL W SIGNAL SH <sub>W</sub> SIGNAL SG SIGNAL SH <sub>B</sub> SIGNAL B	Figure 20
	2 1	Coil Drive (e) Coil Drive (e)	COIL 1 COIL 2	

- a. The terminals are shown in Figures 17 through 20.
- b. These terminals are used with twisted pair cable.
- c. These terminals are used with signal cable (Part number R0101ZS or B4017TE).
- d. Shield and screen are used interchangeably throughout this document.
- e. For 2800, 9100A, and 9200A flowtubes only, connect flowtube coil drive wire “1” to the “2” terminal on the transmitter, and connect flowtube coil drive wire “2” to the “1” terminal on the transmitter.

Figure 15. Wiring of IMT25 Transmitter Single Compartment Enclosure

**TRANSMITTER CONNECTIONS FOR SIGNAL AND COIL DRIVE CABLE IN SINGLE COMPARTMENT ENCLOSURE**

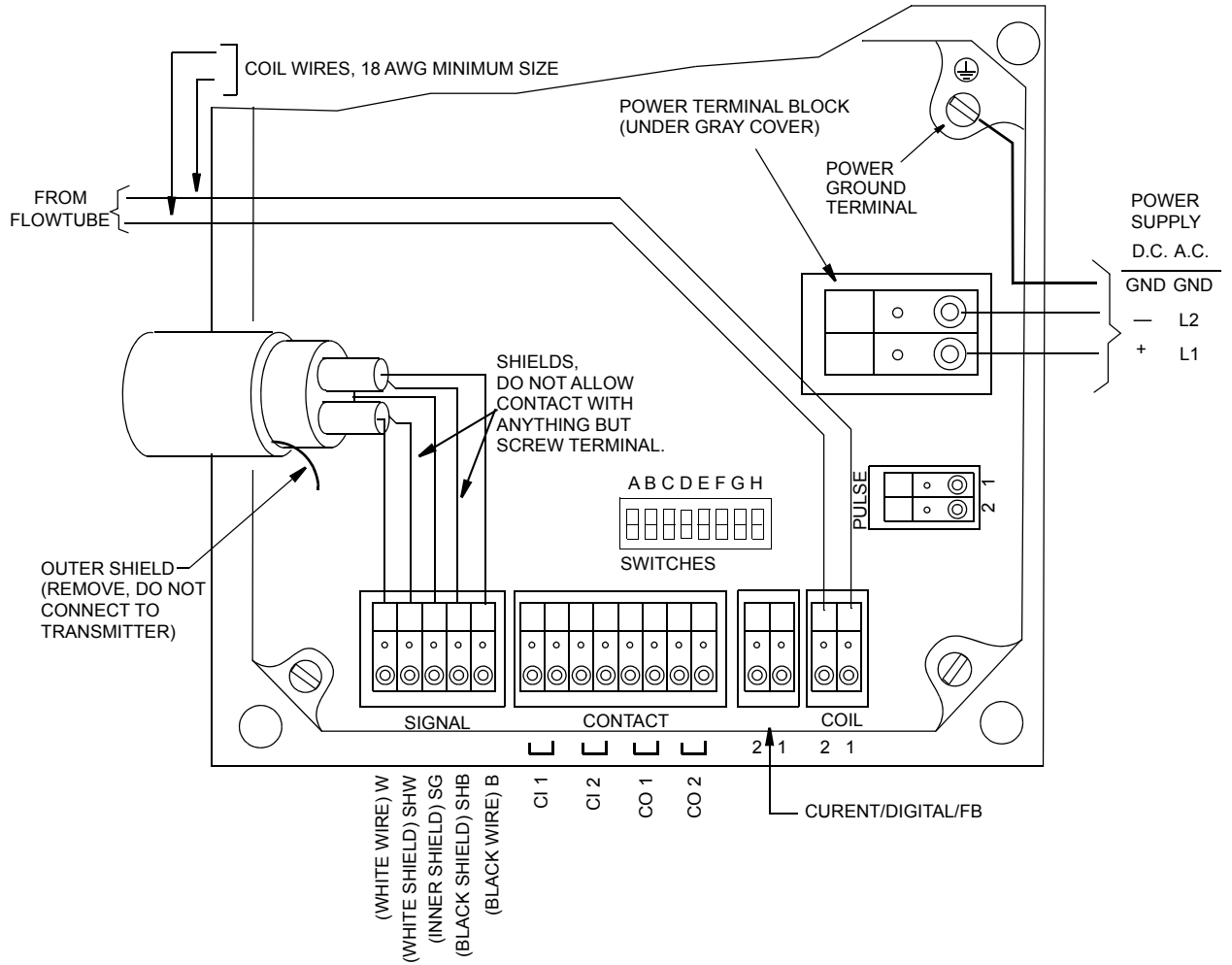

**TRANSMITTER CONNECTIONS FOR TWISTED PAIR SHIELDED CABLE**

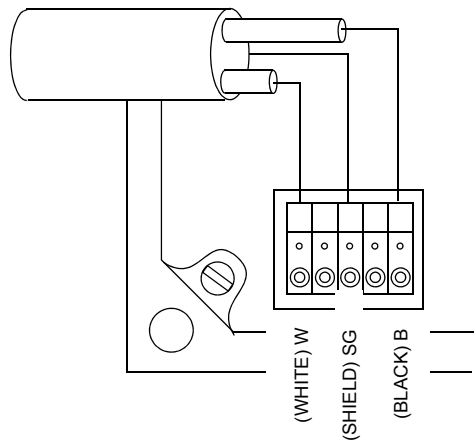

**Figure 16. Wiring of IMT25 Transmitter Dual Compartment Enclosure**  
 (See Figures 12 and 13 for Wire Lead Preparation)

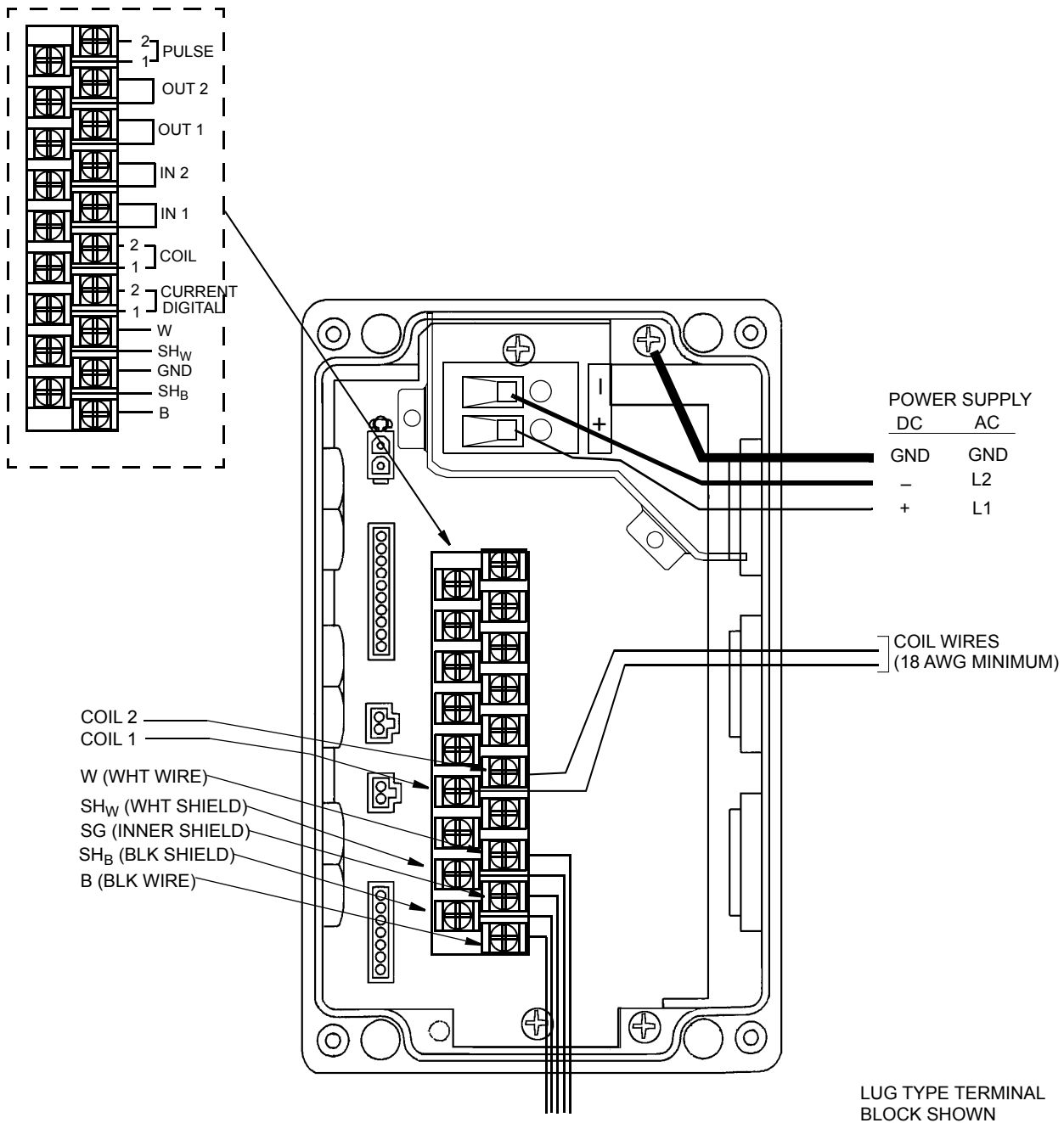

**NOTE**

To maintain a NEMA 4 rating after wiring, the fasteners that attach the cover must be torqued as follows:

- Main housing cover fasteners: 0.14 to 0.17 N-m (20 to 25 lb-in).
- Termination box cover fasteners: 0.07 to 0.10 N-m (10 to 14 lb-in).

## Wiring the Transmitter to a 2800 or 8300 Flowtube

1. Remove the covers from both the flowtube and the transmitter.
2. Run coil-drive and signal cable through the conduit or optional cable glands, as applicable.
3. Connect the signal wires to the flowtube output terminals as shown in Figure 17 or Figure , as applicable.
4. In the flowtube, clamp the transmitter input cable with the cable clamp as shown in Figure 17.
5. If the flowtube has optional cable glands, turn the compression nut (shown in Figure 10) until the rubber gland is snug around the input-signal cable.
6. Remove the protective cover from the coil-drive terminals.
7. Connect the coil drive wires per Table 6.
8. Reinstall the protective cover over the flowtube coil-drive terminals.
9. Reinstall the terminations cover on the flowtube.
10. Connect the signal wires from the flowtube to the transmitter input terminals as shown in Figures 15 and 16.
11. If the transmitter has optional cable glands, turn the compression nut until the rubber gland is snug around the input-signal cable.
12. Connect the coil-drive wires to the transmitter terminals as shown in Figures 15 and 16. Tighten the optional gland compression nuts, if applicable.

*Figure 17. Wiring of 8300 Series Flowtubes*

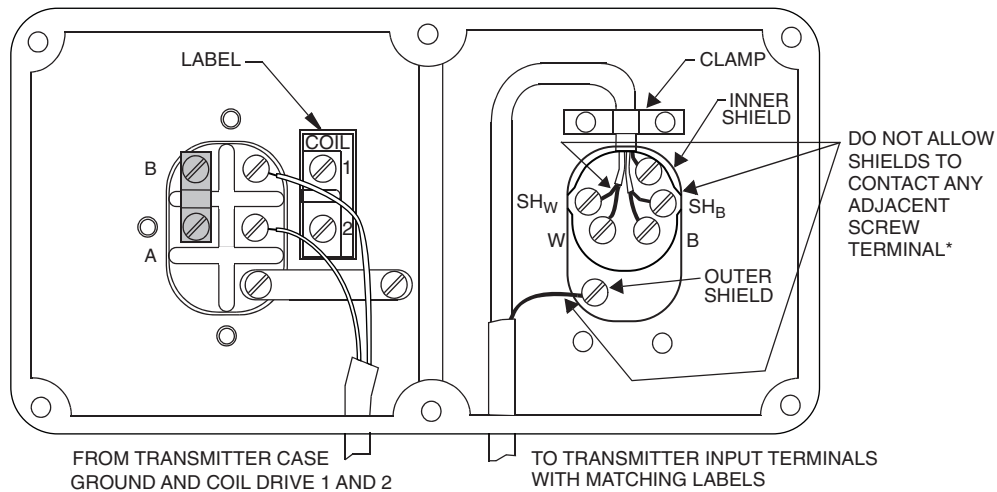

\*TERMINALS SH<sub>W</sub> AND SH<sub>B</sub> ARE NOT USED WITH SHIELDED TWISTED PAIR SIGNAL WIRES.

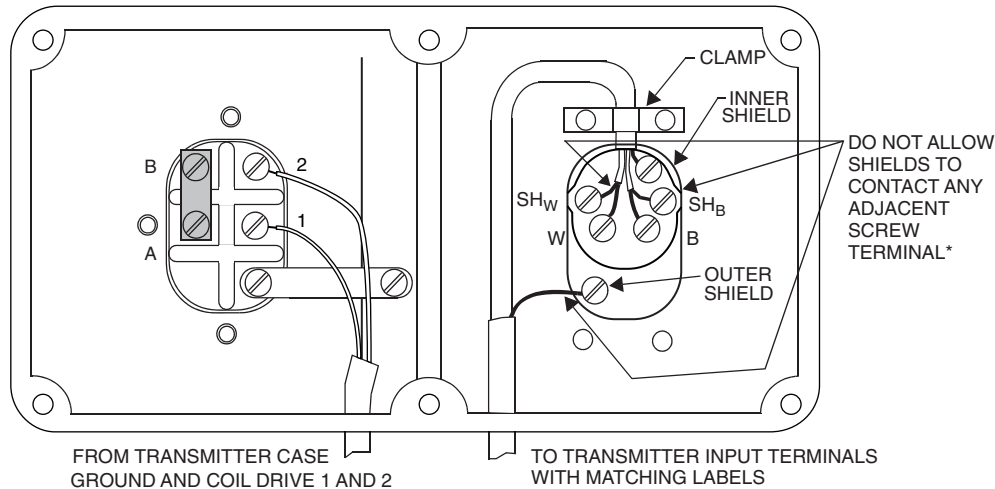
*Figure 18. Wiring of 2800 Series Flowtubes*

\*TERMINALS SH<sub>W</sub> AND SH<sub>B</sub> ARE NOT USED WITH SHIELDED TWISTED PAIR SIGNAL WIRES.

## Wiring the Transmitter to an 8000A, 9100A, 9200A, or 9300A Flowtube

1. Remove the covers from both the flowtube and the transmitter.
2. Run the flowtube coil-drive and signal cable through the conduit or optional cable glands, as applicable.

---

### NOTE

90°C (194°F) wire is adequate if process temperature is below 150°C (302°F).

---

3. Connect the transmitter input wires to the flowtube output terminals as shown in Figures 19 and 20.
4. If the flowtube has optional cable glands, turn the compression nut (shown in Figure 10) until the rubber gland is snug around the input-signal cable.
5. Connect the coil drive wires per Table 6.
6. Reinstall the terminations cover on the flowtube.
7. Connect the input-signal wires from the flowtube to the transmitter input terminals (see Figures 15 and 16).
8. If the transmitter has optional cable glands, turn the compression nut until the rubber gland is snug around the input-signal cable.
9. Connect the coil-drive wires to the transmitter terminals as shown in Figures 15 and 16. Tighten the optional gland compression nuts, if applicable.

*Figure 19. Wiring of 8000A and 9300A Series Flowtubes*

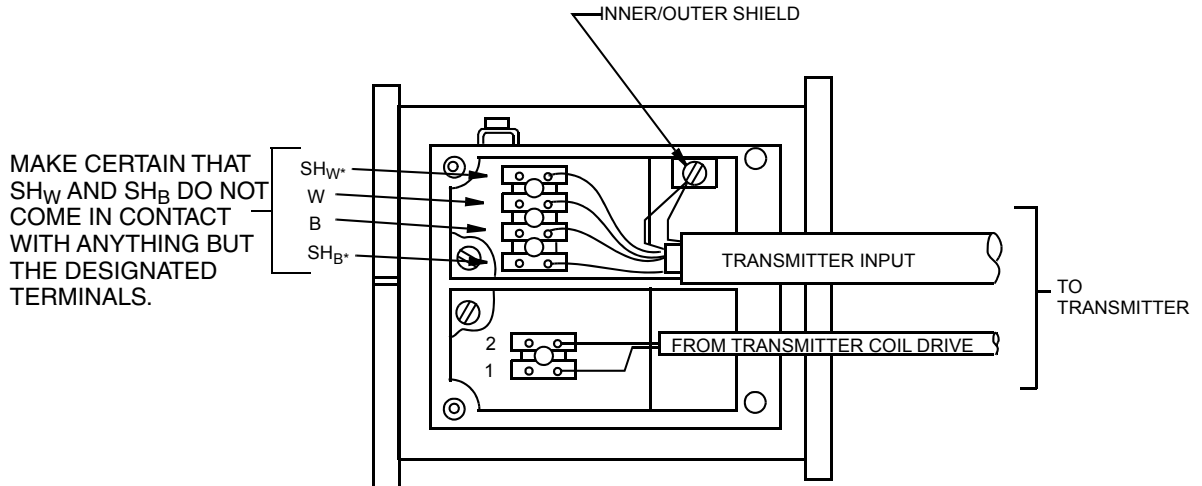

NOTE: GROUND RINGS ARE NEEDED AND MUST BE CONNECTED TO THE GROUND POST ON THE OUTSIDE OF THE JUNCTION BOX.

\*TERMINALS  $SH_W$  AND  $SH_B$  ARE NOT USED WITH SHIELDED TWISTED PAIR SIGNAL WIRING.

**Figure 20. Wiring of 9100A and 9200A Series Flowtubes**

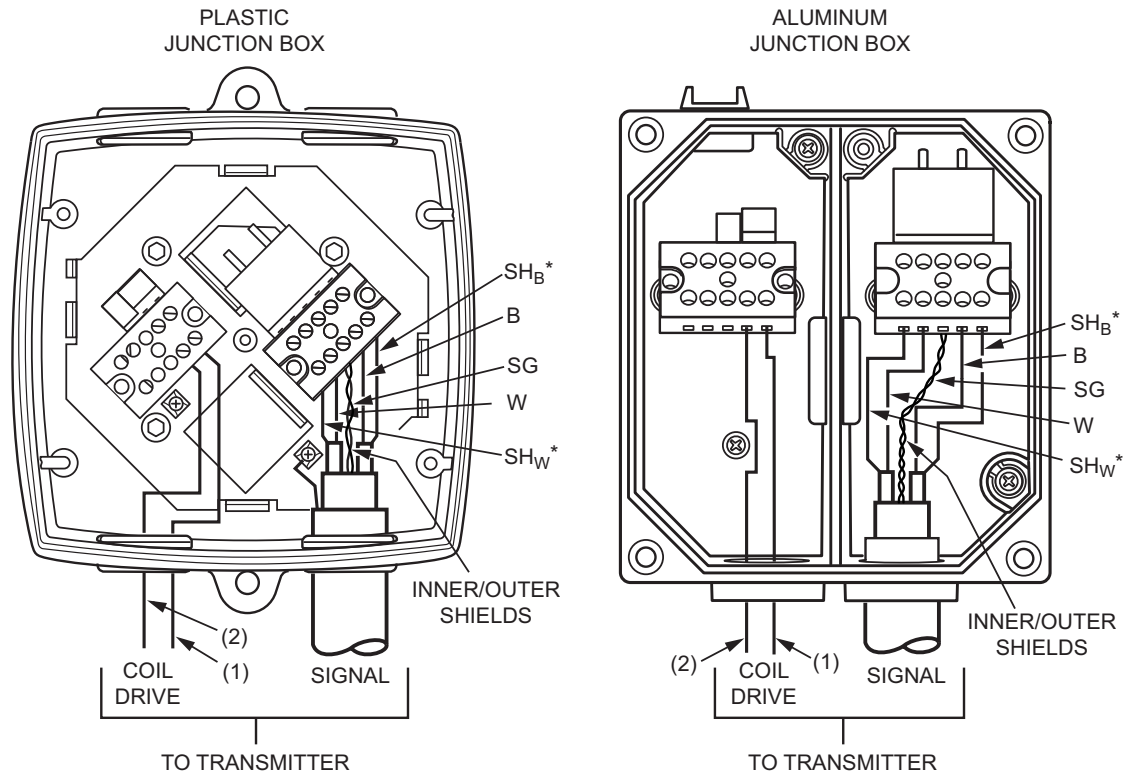

MAKE CERTAIN THAT SH<sub>W</sub> AND SH<sub>B</sub> DO NOT COME IN CONTACT WITH ANYTHING BUT THE DESIGNATED

- SH<sub>B</sub>\* = BLACK SHIELD
- B = BLACK WIRE
- S<sub>G</sub> = INNER SHIELD (SOLUTION GROUND)
- W = WHITE WIRE
- SH<sub>W</sub>\* = WHITE SHIELD

\*SH<sub>B</sub> AND SH<sub>W</sub> ARE NOT USED WITH TWISTED PAIR SIGNAL WIRING.

---

**NOTE**

---

Connect Coil Drive wires per Table 6.

---



# 5. Transmitter I/O Wiring

---

— **NOTE** —

1. Recommended wire for current/digital output, pulse output, and external contact is 0.50 mm<sup>2</sup> (22 AWG) or larger.
  2. Do not tin ends of wires before connecting them to transmitter terminals. Tinned wires can result in poor connections and cause signal noise.
- 

## Accessing Transmitter Wire Terminals

Transmitter wire terminals are accessed by removing the cover from the single compartment enclosure or dual compartment enclosure, as applicable. The covers attach to the enclosure with four captive screws (see Figure 21).

*Figure 21. Accessing Transmitter Wire Terminals*

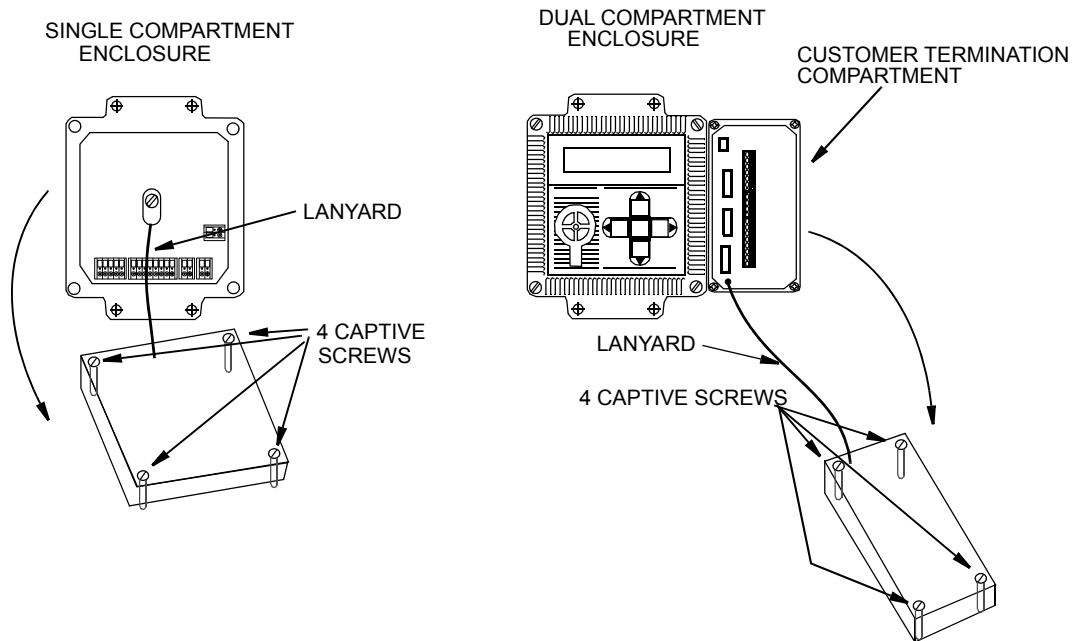

---

— **NOTE** —

To maintain a NEMA 4 rating after wiring, the cover attaching fasteners must be torqued as follows:

- Main housing cover fasteners: 0.14 to 0.17 N-m (20 to 25 lb-in).
  - Termination box cover fasteners: 0.07 to 0.10 N-m (10 to 14 lb-in).
-

## Wiring the Digital Output Circuit

The transmitter digital output signal wiring connects to an I/A Series system. The output signal is superimposed on the 4 to 20 mA (loop) lines. This procedure identifies only transmitter wire terminations to the system. For other system wiring details, refer to the “Installation” instructions in the documentation provided with the I/A Series system. The maximum length of field wire is 600 m (2000 ft). Signal output power is supplied by the FBM Input Module. Typical digital output signal wiring is shown in Figure 22. For wiring an externally powered current output circuit, see next section.

---

### — NOTE —

When internally powered, the current/digital, pulse output, and contact input circuits share the same circuit reference. They are isolated from other circuits but not from each other.

---

*Figure 22. Typical Digital Output Signal to an I/A Series System, HART Communicator, and PC-based Configurator*

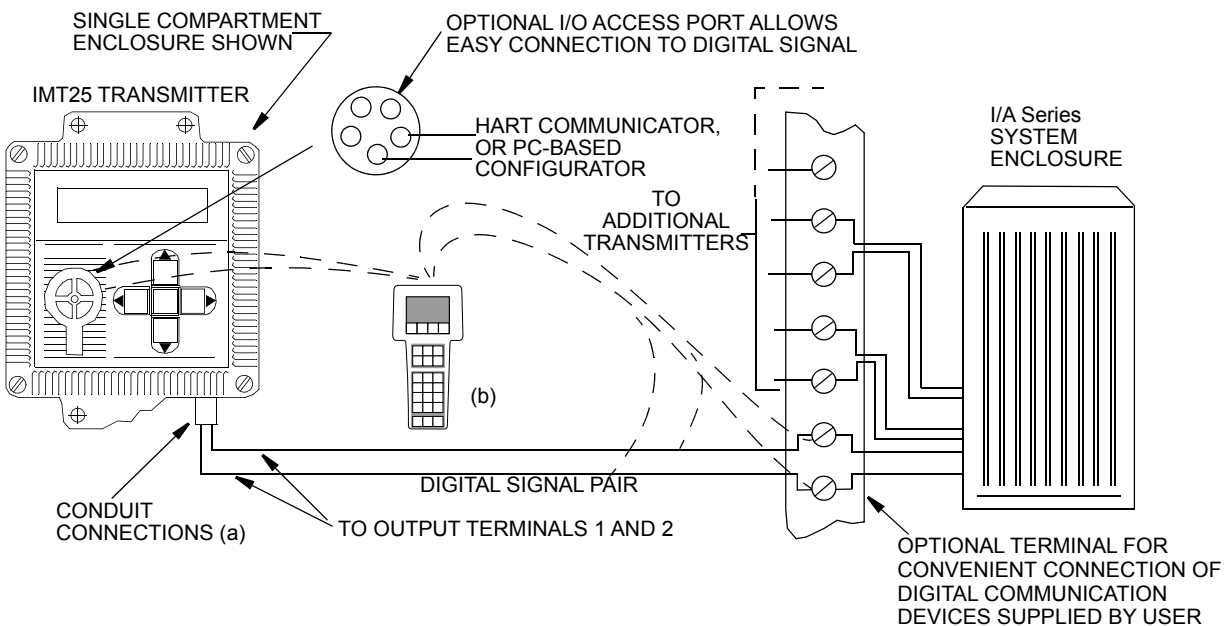

(a) RUN CONDUIT DOWN TO AVOID BUILDUP OF MOISTURE IN TERMINALS COMPARTMENT. PLUG ANY UNUSED CONDUIT CONNECTION.

(b) A HART COMMUNICATOR OR PC-BASED CONFIGURATOR CAN BE CONNECTED ANYWHERE BETWEEN THE TRANSMITTER FIELD TERMINALS AND THE EXTERNAL LOAD OR TO THE OPTIONAL I/O PORT.

1. Run signal wires (0.50 mm<sup>2</sup> or 22 AWG, typical) through the predetermined conduit connection on the transmitter. Connect wires to transmitter current/digital terminals shown in Figure 23. Use twisted signal pair to help protect the digital output and/or remote communications from electrical noise. Shielded cable is required in some locations.

---

### — NOTE —

Do not run signal wires in the same conduit as mains (ac power) wires.

---

2. If shielded cable is used, ground the shield at the field enclosure only. Do not ground the shield at the transmitter.

**NOTICE**

**POTENTIAL REDUCED PERFORMANCE OR EQUIPMENT DAMAGE**

If the signal circuit must be grounded, it is preferable to do so at the negative terminal of the dc power supply. To avoid errors resulting from ground loops or the possibility of short-circuiting groups of instruments in a loop, there should be only one ground in a loop.

**Failure to follow these instructions can result in reduce performance or equipment damage.**

3. The HART Communicator or PC-based Configurator can be connected to the signal wires at the transmitter terminals through the optional I/O port (see Figure 22) or other convenient locations in the loop (subject to certain restrictions). If desired, connect terminal strips at convenient locations (see Figure 22). For example, to communicate with several transmitters from a single location, connect each pair of signal wires to a separate pair of terminals. The HART Communicator or PC-based Configurator can then be easily disconnected from one loop and connected to another.
4. The location of terminal blocks in the I/A Series system enclosure depends both on the type of enclosure purchased and on the location of the transmitter input module inside the enclosure. To determine the terminal-block location for a particular system, refer to the “Installation” instructions in the loadable documentation provided with the I/A Series system.

## Current Output and Pulse Output Wiring

Locations of current output and pulse output terminals are shown in Figure 23. Wiring to these terminals is shown in Figures 25 through 28.

*Figure 23. Location of Current Output and Pulse Output Terminals*

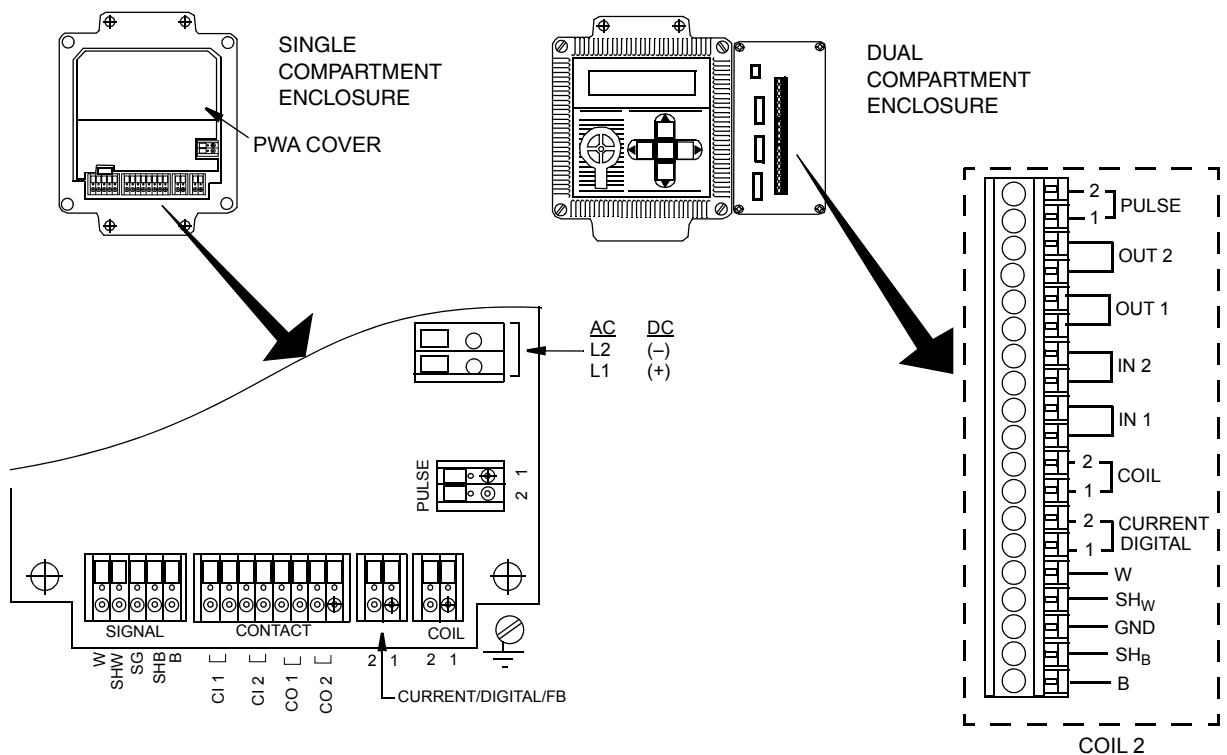

**NOTE**

1. When internally powered, the current/digital, pulse output, and contact input circuits share the same circuit reference. They are isolated from other circuits but not from each other.
2. Grounding the internally powered pulse at pin 1 is recommended, but not required; grounding externally powered pulse output at the negative terminal of the power supply is also recommended. See Figures 27 and 28.
3. Internal or external power is set by switches. Refer to “Switch Settings” on page 18 to verify or change the switch settings.

The supply voltage and loop load relationship for the 4 to 20 mA output wiring is shown in Figure 24. Any combination of supply voltage and loop load resistance in the lower shaded area can be used. To determine the total loop load resistance, add the series resistance of each component in the loop, excluding the flowmeter. The power supply must be capable of supplying 25 mA of loop current. The internal power supply is 24 V dc.

*Figure 24. Supply Voltage and Loop Load Requirements for Externally Powered Current Output Circuits*

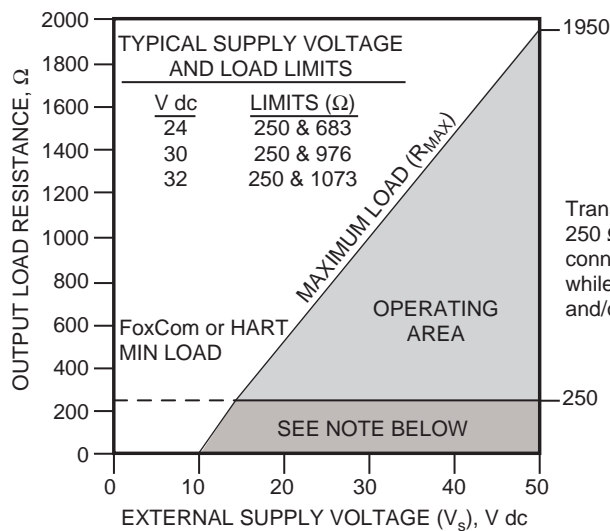

$$R_{max} = \frac{(V_s - 10)}{0.0205}$$

**NOTE**

Transmitter will function with output load less than 250 Ω provided an external configurator is not connected to it. Connecting an external configurator while operating in this area may cause disturbances and/or communication problems.

**Examples:**

1. For an installation with a total loop load resistance of 500 ohms, the supply voltage can be any value from 20 to 50 V dc.
2. For a supply voltage of 24 V dc, the loop load resistance can be any value from 0 to 683 Ω. If a HART Communicator or PC-based Configurator is used, a minimum loop resistance of 250 Ω is required.

**NOTE**

Grounding the loop at the negative terminal of the power supply is recommended but not required. If shielded wire is used for this signal, terminate the shield at the negative terminal of the power supply.

**NOTICE**

**POTENTIAL REDUCED PERFORMANCE OR EQUIPMENT DAMAGE**

If the signal circuit must be grounded, it is preferable to do so at the negative terminal of the dc power supply. To avoid errors resulting from ground loops or the possibility of short-circuiting groups of instruments in a loop, there should be only one ground in a loop.

**Failure to follow these instructions can result in reduce performance or equipment damage.**

*Figure 25. Current Output Wiring - Internal Power*

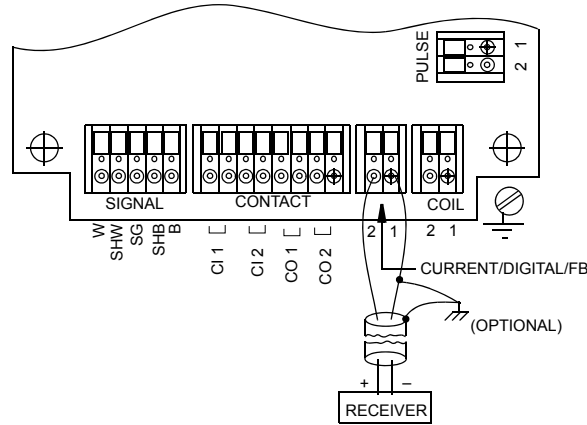

*Figure 26. Current Output Wiring - External Power*

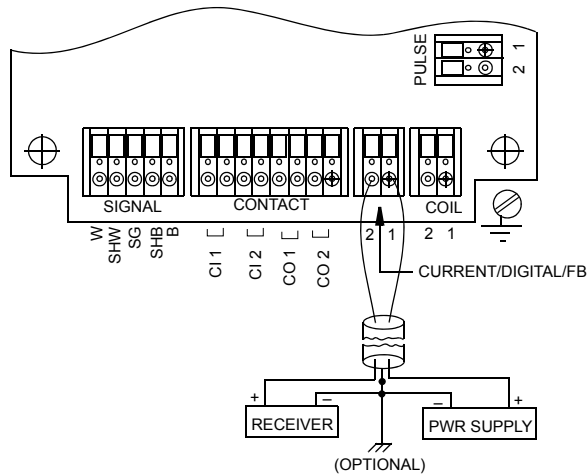

Figure 27. Pulse Output Wiring - Internal Power

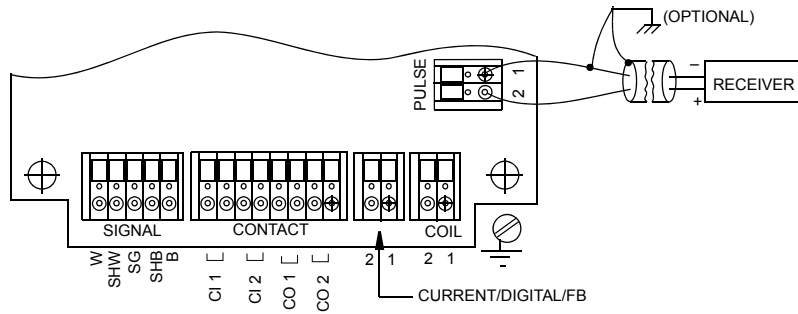
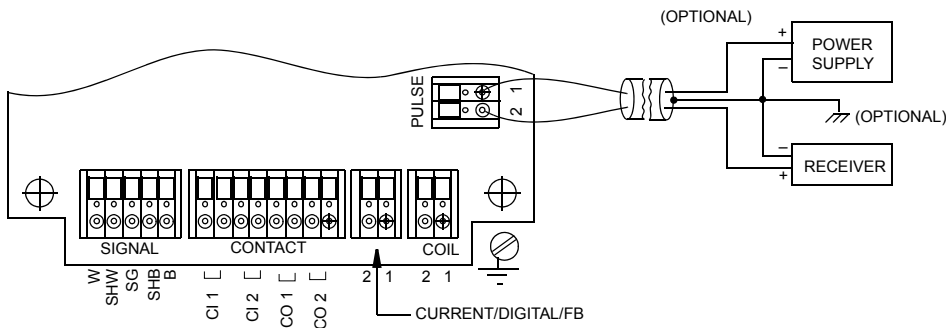

Figure 28. Pulse Output Wiring - External Power



The pulse output has two modes of operation:

- ◆ Scaled pulse mode — used to drive a remote totalizer
- ◆ Rate mode — used to transmit flow rate as a frequency

To install the pulse output wiring correctly, the pulse output mode must be known.

**Scaled Pulse Mode**

For scaled pulse mode, observe the following supply voltage or load current limits:

- Supply Voltage: 5 V dc min. to 42 V dc max.
- Load Current: 1 mA min. to 80 mA max.

**Rate Mode**

For rate mode, other considerations for proper circuit operation apply:

1. To maintain a low state voltage of 1 V max. at the receiver, observe the following load resistance range:

Table 7. Load Resistance Range to Maintain Low State Voltage = 1 Volt max.

Load Resistance	Supply Voltage		
	5 V	24 V	42 V
R <sub>min</sub>	62.5 ohms	300 ohms	525 ohms
R <sub>max</sub>	5000 ohms	5000 ohms	5000 ohms

2. When lead capacitance (C) and lead length (L) are considered, more stringent load resistance (R) restrictions apply. For correct operation in the rate mode:

$$R_{\max} = \frac{K}{CL}$$

where

$K = 5 \times 10^{-6}$	for max Freq = 10 kHz
$10 \times 10^{-6}$	for max Freq = 5 kHz
$25 \times 10^{-6}$	for max Freq = 2 kHz
$50 \times 10^{-6}$	for max Freq = 1 kHz

C = capacitance in farads

L = length in feet

Example:

- If: Cable Length is 1000 ft  
 Cable Capacitance is 20 pF/ft  
 Desired maximum frequency is 5 kHz

Then:  $R_{\max} = 10 \times 10^{-6} / ((20 \times 10^{-12}) \times (1000))$   
 $= 500 \text{ ohms}$

Verify that the calculated value of  $R_{\max}$  falls within the limits defined in Table 7.

In general, smaller loads support higher frequencies and/or longer cable lengths. Inversely stated, lower frequencies support longer cable lengths and/or larger loads.

When confronted with a situation in which the input impedance of the receiving device is too large for the desired frequency and/or lead length, you can install a shunting resistor across the appropriate terminals of the receiver to satisfy the requirements stated above.

## Contact Input/Output Wiring

Figure 29. Contact Input Wiring

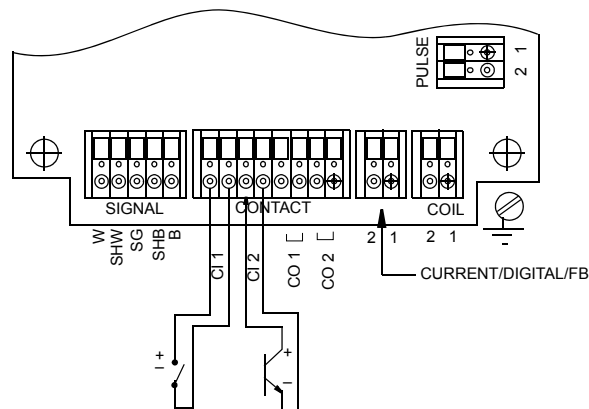

The contact inputs require a contact closure or transistor switch between the terminal block connections provided.

The open circuit voltage is 24 V dc  $\pm$ 15%.

The closed circuit current is 12 mA  $\pm$ 15%.

*Figure 30. Contact Output Wiring*

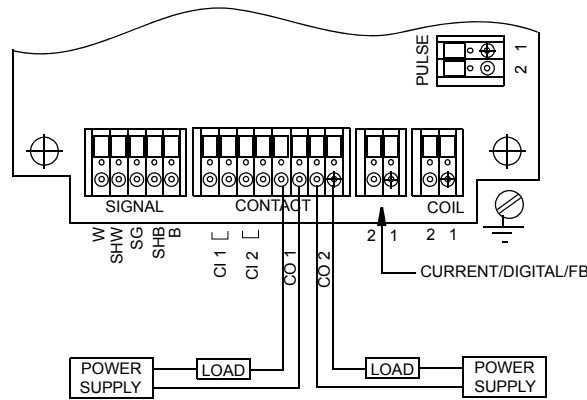

Voltage rating: 60 V dc maximum, 30 V ac rms maximum

Current rating: 3 A maximum resistive

Contact outputs are not short-circuit proof. External fuses are required if this feature is necessary.

Inductive loads can be driven with external shock wave absorbing devices installed across contact terminations.

## FOUNDATION Fieldbus Output Wiring

The transmitter output signal wiring connects to a FOUNDATION fieldbus segment. The procedure on the following page describes the wiring between transmitter and the fieldbus system only. For other system wiring details, refer to the “Installation” instructions in the documentation provided with the fieldbus host system. Signal output power is supplied via the fieldbus from a fieldbus power supply module. For maximum cable lengths, refer to Fieldbus Foundation documents AG-130 and AG-140, listed in “Reference Documents” on page 11.



Figure 31. Fieldbus Output Wiring

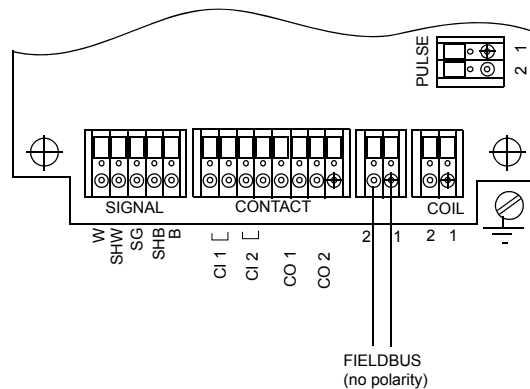

Use twisted signal pair to help protect the remote communications from electrical noise. Shielded cable is required in some locations. If shielded cable is used, ground the shield at the field enclosure only. Do not ground the shield at the transmitter.

---

— **NOTE** —

---

Do not run signal wires in the same conduit as mains (ac power) wires.

---

**NOTICE**

**POTENTIAL REDUCED PERFORMANCE OR EQUIPMENT DAMAGE**

If the signal circuit must be grounded, it is preferable to do so at the negative terminal of the dc power supply. To avoid errors resulting from ground loops or the possibility of short-circuiting groups of instruments in a loop, there should be only one ground in a loop.

**Failure to follow these instructions can result in reduce performance or equipment damage.**

## Transmitter Mains (Power) Wiring

For access to the mains terminals, remove the front cover of the single compartment enclosure, or the field terminal cover of the dual compartment enclosure.

After completing all transmitter wiring, plug any unused conduit connection and reinstall the applicable cover.

---

— **NOTE** —

---

1. Recommended wire type and size is 3-core (3-conductor) 2.50 mm<sup>2</sup> (14 AWG) or correct type and size in conformance with local wiring practice.
  2. Local agency requirements take precedence for mains wiring and grounding. If no grounded neutral wire is available, connect protective ground to plant safety ground.
-

Figure 32. Mains (Power) Wiring

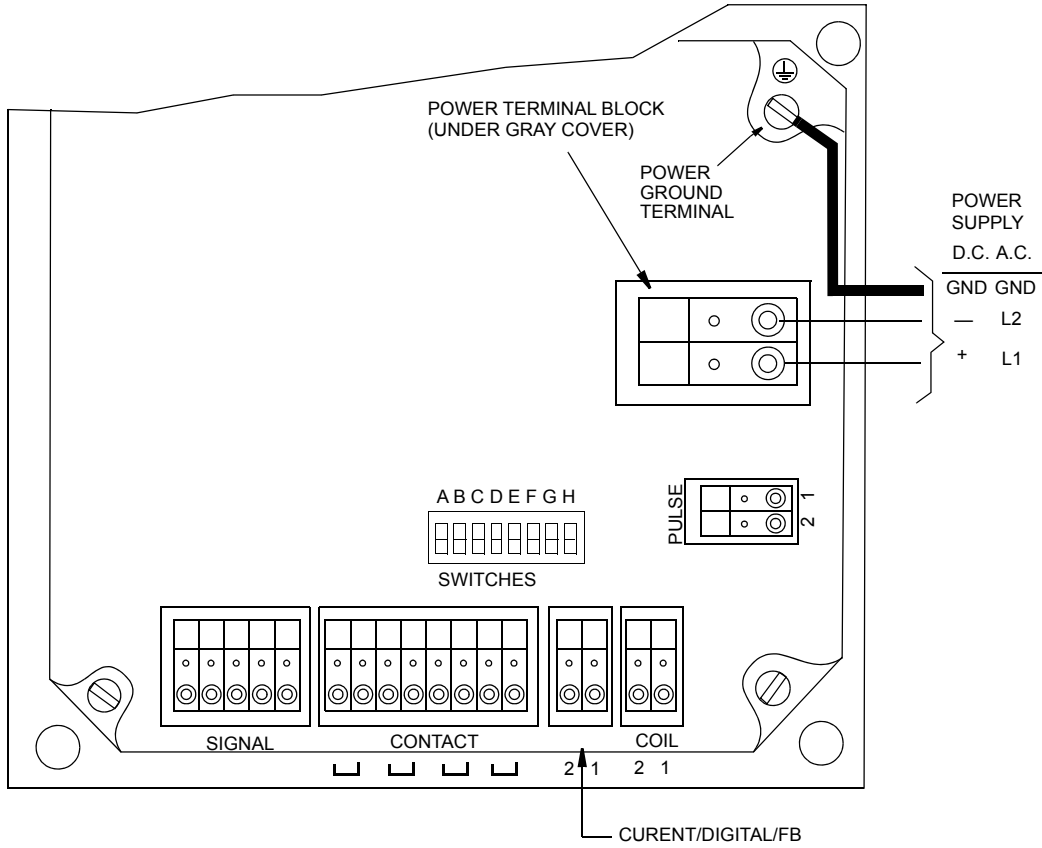

# 6. Installing Fieldbus Software

IMT25 Magnetic Flow Transmitters with FOUNDATION fieldbus communication are shipped with a CD-ROM that contains specific device information and other files needed to configure the transmitters from a FOUNDATION fieldbus host. The files included on the CD-ROM are:

Filename	Description
readme.doc	A WORD file with DD installation instructions
readme.txt	A text file with DD installation instructions (for users without MS-WORD).
xxyy.fo	DD binary file
where	xx = Device Rev. (Parameter 12 in Resource Block) yy = DD Rev. (Parameter 13 in Resource Block)
xxyy.sym	DD symbol file
xxbbzz.cff (a)	Capability File (zz = cff rev)

a. 'bb' may be the same as 'yy' or may be 'ff'.

Set up the following directory structure for the DD files of a device on the host computer. According to the FOUNDATION specification, the device description files must be present in the appropriate directories as described below.

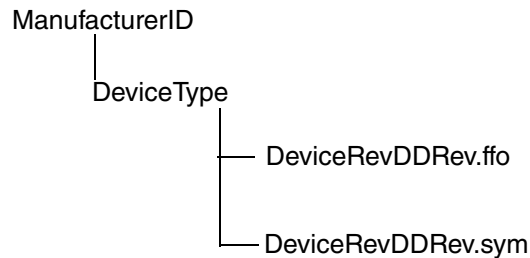

where \*.fo is the DD binary file and \*.sym is the symbol file.

The Manufacturer ID is 385884 and the Device Type for this vortex transmitter is BC29.

---

**— NOTE**

The applicable DD and capability files are also available at [www.fieldbus.org](http://www.fieldbus.org).

---

**ISSUE DATES**

MAR 1996	DEC 1997	OCT 2004	DEC 2008
MAY 1996	JUN 1998	APR 2005	FEB 2016
JUN 1996	JUN 2001	JUN 2006	JAN 2018
MAR 1997	AUG 2004	SEP 2007	MAY 2018

Vertical lines to the right of text or illustrations indicate areas changed at last issue date.

Schneider Electric Systems USA, Inc.  
38 Neponset Avenue  
Foxboro, MA 02035  
United States of America  
<http://www.schneider-electric.com>

Global Customer Support  
Inside U.S.: 1-866-746-6477  
Outside U.S.: 1-508-549-2424  
<https://pasupport.schneider-electric.com>

Copyright 1996-2018 Schneider Electric Systems USA, Inc. All rights reserved.

Schneider Electric and I/A Series are trademarks of Schneider Electric Systems USA, Inc., its subsidiaries, and affiliates. All other trademarks are the property of their respective owners.

