

# SpaceLogic Sensors

## SLA Series PM Sensors – Analog



Note: A subset of models shown.

### Product Description

The SpaceLogic SLA PM (Particulate Matter) Series of air quality sensors for living space is a flexible multisensor platform for use with BAS controllers designed to accept 4 to 20mA, 0 to 5Vdc or 0 to 10Vdc outputs. Housings are available in Medium matte white and Optimum faces available in black and white. All housing types are available with touchscreen and blank user interface options. Touchscreen models offer an all-in-one sensor with temp, RH, CO<sub>2</sub> and PM; while the blank model offers only PM to best suit retrofit environments.

### Features

- Medium matte white housing or optimum glass panel housing available in white or black
- Laser-scatter type PM sensor featuring innovative contamination resistance technology for highly accurate measurement of particulate matter
- Manual and auto field calibratable non-dispersive infrared CO<sub>2</sub> sensor
- Quick to commission with DIP switch selectable outputs
  - 4-20 mA, 0 to 5 Vdc or 0 to 10 Vdc
  - CO<sub>2</sub>: 0 to 2000/5000 ppm
- Temperature output value shown as default main value on Touchscreen displays
- Temperature setpoint toggle function for touchscreen sensors
- 61 mm (2.4") backlit color touchscreen
  - Digital temperature indication (0.1° display resolution of °F or °C)
  - Digital humidity indication (0.1% RH display resolution)
  - Digital CO<sub>2</sub> indication
    - 0 to 10,000 ppm output
    - 1 ppm resolution
  - Selectable CO<sub>2</sub> output range from 0 to 2000 ppm or from 0 to 5000 ppm
  - Stoplight feature for visual indication at user-configurable CO<sub>2</sub> and PM2.5 threshold levels (touchscreen models only)
  - Selectable temp, RH and fan speed setpoint (0-10V)
  - Configurable screen lock and display timeout
  - Override
- 18-24 AWG screw terminals

### Available Products

Model	Description	User Interface	Housing Finish
SLASTCP2	Sensor, PM2.5, CO <sub>2</sub> , RH, Touch, Analog	Touchscreen	Medium White
SLABTCP2	Sensor, PM2.5, CO <sub>2</sub> , RH, Touch, Analog, Optm Bk	Touchscreen	Optimum Black
SLAWTCP2	Sensor, PM2.5, CO <sub>2</sub> , RH, Touch, Analog, Optm Wh	Touchscreen	Optimum White
SLASXXPX	Sensor, PM1, PM2.5, PM4, PM10, Analog	Blank	Medium White
SLABXXPX	Sensor, PM1, PM2.5, PM4, PM10, Analog, Optm Bk	Blank	Optimum Black
SLAWXXPX	Sensor, PM1, PM2.5, PM4, PM10, Analog, Optm Wh	Blank	Optimum White

### Replaceable PM Elements

Model Number	Description
SLXPMS	Replaceable Module, PM

USA: +1 888-444-1311  
 Europe: +46 10 478 2000  
 Asia: +65 6484 7877  
[www.schneider-electric.com](http://www.schneider-electric.com)

Life Is On

**Schneider**  
Electric

## Specifications

Operating Environment	
Input power	Class 2; 20 to 30 Vdc, 24 Vac, 50 to 60 Hz
Analog output	Selectable 4 to 20 mA, 0 to 5 V, 0 to 10 V
Operating temp. range	0 to 50 °C (32 to 122 °F)
Operating humidity range	0 to 95% RH non-condensing
Housing material	High impact ABS plastic
IP rating	IP 30
Mounting location	For indoor use only. Not suitable for wet locations.
Surface mount	The device can be surface mounted on Single Gang J-Box, British Standard and CE60 wall boxes
PM Sensor	
Sensor type	Laser-scatter
Output range	0 to 1,000 µg/m <sup>3</sup>
Accuracy	PM 1 and PM 2.5: 0 to 100 µg/m <sup>3</sup> +/-[5µg/m <sup>3</sup> +5% m.v.], 100 to 1,000 µg/m <sup>3</sup> +/-[10% m.v.] PM 4 and PM 10*: 0 to 100 µg/m <sup>3</sup> +/-[25µg/m <sup>3</sup> ], 100 to 1,000 µg/m <sup>3</sup> +/-[25% m.v.] (sensor-to-sensor deviation)
Resolution	0.1 µg/m <sup>3</sup>
CO <sub>2</sub> Sensor	
Sensor type	Non-dispersive infrared (NDIR), diffusion sampling
Output range	0 to 2,000/5,000 ppm (selectable)
Accuracy	±30 ppm ±3% of measured value
Resolution	1 ppm
Repeatability	±20 ppm ±1% of measured value
Response time	<60 seconds for 90% step change
RH Sensor	
Sensor type	Solid state capacitive, replaceable
Output range	0 to 100% RH
Accuracy (includes hysteresis)**	±3.8% RH from 10 to 60% RH @ 25°C (77 °F) ±4.8% RH from 60 to 80% RH @ 25°C (77 °F) ±5.8% RH from 80 to 100% RH @ 25°C (77 °F)
Resolution	0.1% RH
Linearity	Included in accuracy specification
Stability	±1% @ 20°C (68 °F) annually for 2 years
Temperature coefficient	±0.1% RH/°C above or below 25 °C (77 °F) typical
Temperature Sensor	
Sensor type	Solid state, integrated circuit
Output range	0 to 50 °C (32 to 122 °F)
Accuracy	±0.2 °C (±0.4 °F) typical
Resolution	0.1 °C (0.1 °F)

Display Models	
Touchscreen	61 mm (2.4 in), color, backlit, capacitive, 240x300px Setpoint: 0-10Vdc. Temperature, humidity or fan speed selectable Timeout override: Display timeout** Lockout override: Touchscreen/button lockout**
Setpoints***	
Temperature setpoint	0 to 10V output Scale: 10 to 35 °C (50 to 95 °F) / 0 to 50 °C (32 to 122 °F)
Humidity setpoint	0 to 10V output Scale: 0 to 100% RH
Fan speed setpoint	0 to 10V output Off 0V, Auto 1.5V, Low 3.3V, Med. 6.7V, High 10.0V
Override	
Override button	Display models feature momentary-to-ground override button
Wiring Terminals	
Terminal blocks	Screw terminals, 18-24 AWG
Screw terminal torque	0.2 N-m (2.0 in-lbf) max.
Regulatory Information	
Agency approvals	UL 916, European conformance CE: EN 60730-1 EN 60730-2-9 EN 60730-2-13 EN 61000-6-2 EN 61000-6-3 EN 61000 Series - Industrial Immunity EN 61326-1 FCC Part 15 Class B, REACH, RoHS, Green Premium, RCM (Australia), ICES-003 (Canada), UKCA (UK)

\*PM4 and PM10 output values are calculated based on distribution profile of all measured particles.

\*\*Humidity sensor overall accuracy should include: accuracy, temperature coefficient and stability. Humidity accuracy is shown as an absolute value, so if testing accuracy with a hand-held device, you must check for deviation in its readings instead of calculating the percentual deviation. Additionally, you must consider the overall accuracy of the hand-held device in the comparison.

\*\*\*DIP switch selectable.

USA: +1 888-444-1311  
Europe: +46 10 478 2000  
Asia: +65 6484 7877  
www.schneider-electric.com

Life Is On

**Schneider**  
Electric

### Dimensions mm (in.) Optimum Housing

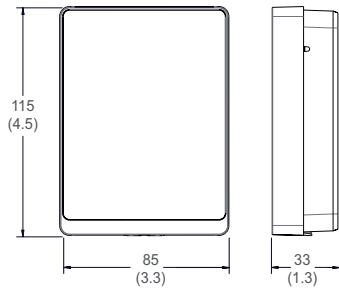

### Medium Housing

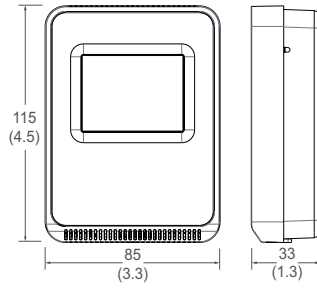

### Base Hole Measurement

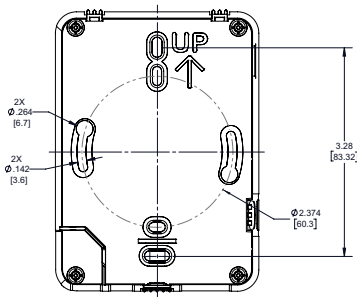

### Safety Information Important Information

Read these instructions carefully and look at the equipment to become familiar with the device before trying to install, operate, service or maintain it. The following special message may appear throughout this bulletin or on the equipment to warn of potential hazards or to call attention to information that clarifies or simplifies a procedure.

#### NOTICE

NOTICE is used to address practices not related to physical injury.

#### ⚠ WARNING

WARNING indicates a hazardous situation which, if not avoided **could result in death or serious injury**.

### Please Note

Electrical equipment should be installed, operated, serviced and maintained only by qualified personnel. No responsibility is assumed by Schneider Electric for any consequences arising out of the use of this material.

A qualified person is one who has the skills and knowledge related to the construction, installation and operation of electrical equipment and has received safety training to recognize and avoid the hazards involved.

### Safety Precautions

#### ⚠ WARNING



#### HAZARD OF ELECTRIC SHOCK, EXPLOSION OR ARC FLASH

- Apply appropriate personal protective equipment (PPE) and follow safe electrical work practices. See NFPA 70E or CSA Z462.
  - This equipment must only be installed and serviced by qualified electrical personnel.
  - Turn off all power supplying this equipment before working on or inside equipment.
  - Always use a properly rated voltage sensing device to confirm power is off.
  - Replace all devices, doors and covers before turning on power to this equipment.
- Failure to follow these instructions can result in death, serious injury or equipment damage.**

This product is intended for use in HVAC and building environmental control applications.

It is not intended for direct medical monitoring of patients.

Read and understand these instructions before installing this product.

The installer is responsible for all applicable codes.

If this product is used in a manner not specified by the manufacturer, the protection provided by the product may be impaired. No responsibility is assumed by the manufacturer for any consequences arising out of the use of this material.

#### NOTICE

##### PRODUCT DAMAGE AND INACCURATE READINGS

- Mount product vertically at a height that is between 3 to 5 feet (0.9 to 1.5 meters) above the floor [or 4 feet (1.2 meters) where the Americans with Disabilities Act needs to be followed]
- Mount product on a wall that is NOT exposed to the outside
- Install product far from windows, heat sources, door frames and at a minimum distance of 6 inches (15 centimeters) from any corner
- Drafts through conduits or other holes in the wall should be eliminated by plugging appropriate material into the cavity.
- This product is specified for environments with stable natural airflow. In dynamic airflow conditions, sensor performance may deviate from expected values. In stable elevated airflow, an offset feature can be applied. Refer to ZL0241-xx, *Field Offset Adjustment Procedure for SLA and SLP Temperature and Humidity Outputs* on [www.se.com/myschneider](http://www.se.com/myschneider) for further information. The offset functionality only exists on units containing a second DIP switch bank dedicated to the offset feature.
- Keep product wall mounted and the base cleared of any wire or other external material:

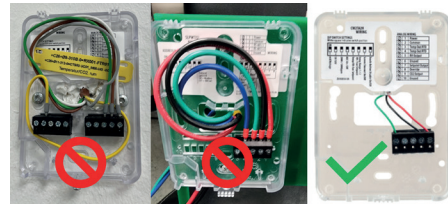

**Failure to follow instructions can result in reduced accuracy, equipment damage or sensor fault.**

USA: +1 888-444-1311  
Europe: +46 10 478 2000  
Asia: +65 6484 7877  
[www.schneider-electric.com](http://www.schneider-electric.com)

Life Is On

Schneider Electric

## Installation

1. Remove the cover from the base at the bottom of the device.



2. Position the sensor base vertically on the wall 1.35 m (4.5 ft.) above the floor with the “UP” arrow facing upward. Locate away from windows, vents and other sources of draft. If possible, do not mount on an external wall, as this may cause inaccurate temperature readings.



3. Pull 18 or 22 AWG cable(s) through the hole in the backplate.

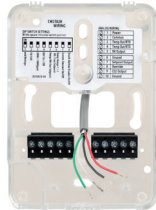

4. Mount the backplate onto the wall using the screws provided.

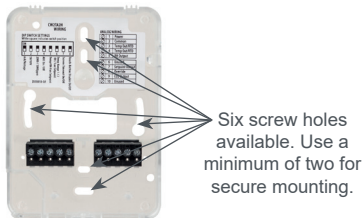

5. Connect the wires to the screw terminals. Do not over-tighten the screws.

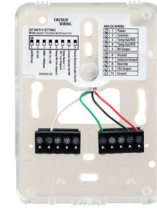

### Wiring Diagram – Touchscreen Models:

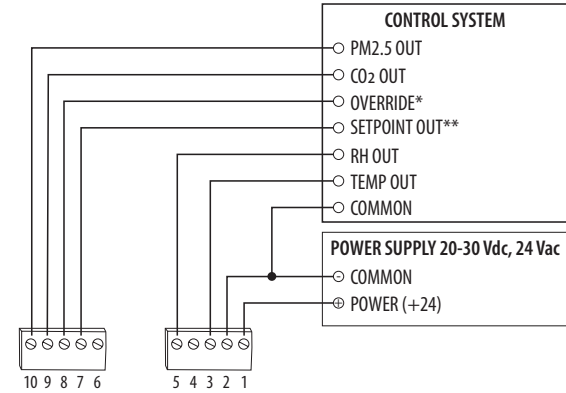

\* Momentary to ground.

\*\* 0-10V DIP switch selectable for temperature, RH (if equipped) or fan speed (off, 0V, Auto 1.5V, Low 3.3V, Medium 6.7V or high 10V).

### Wiring Diagram – Blank Cover Models:

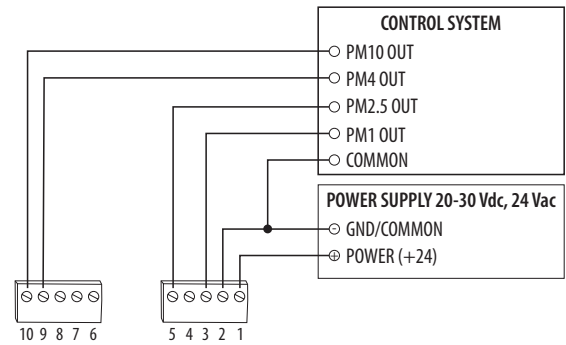

Installation (cont.)

6. Set the DIP switches.

Left DIP Switches – Touchscreen Models:

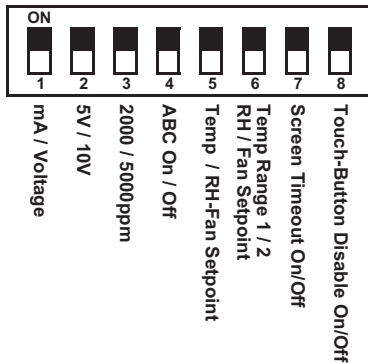

Left DIP Switches – Blank Cover Models:

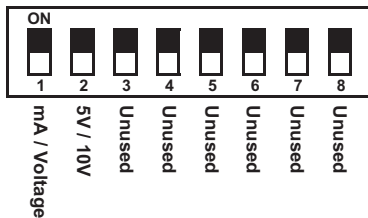

Switch	Function	Description
1	Output mode	ON - 4-20mA output mode enabled OFF - Voltage output mode enabled
2*	Voltage output range	ON - 0-5V output range enabled OFF 0-10V output range enabled
3**	CO <sub>2</sub> output range	ON - 0-2000 ppm CO <sub>2</sub> output range enabled OFF - 0-5000 ppm CO <sub>2</sub> output range enabled
4**	Automatic Baseline Calibration (ABC) for CO <sub>2</sub>	ON - ABC enabled OFF - ABC disabled
5**	Setpoint output type	ON - Temperature setpoint enabled (temp range selected on DIP switch 6) OFF - RH or Fan Speed setpoint enabled (specific setpoint output type to be selected on DIP switch 6) Models without RH option select only temp or fan setpoint

Switch	Function	Description
6**	Setpoint output temperature range or RH/Fan Speed output type	Temperature setpoint (must be enabled on DIP switch 5) ON - Temp range 1, 50 to 95 °F (10 to 35 °C) enabled OFF - Temp range 2, 32 to 122 °F (0 to 50 °C) enabled  RH or Fan Speed setpoint (must be enabled on DIP switch 5) ON - RH setpoint enabled OFF - Fan Speed setpoint enabled Models without RH option, set to OFF
7**	Display times out and turns off after 6-10 seconds of touchscreen/button press	ON - Display Timeout enabled OFF - Display Timeout disabled
8**	Touchscreen touch functions and buttons are disabled	ON - Touchscreen touch/button functions disabled OFF - Touchscreen touch/button functions enabled

\*Only used with voltage output mode enabled. Not applicable to setpoint output. Setpoint is 0-10V fixed.  
\*\*Switch only used on touchscreen models.

Note: This product is specified for environments with stable natural airflow. In dynamic airflow conditions, sensor performance may deviate from expected values. In stable elevated airflow, an offset feature can be applied. Refer to ZL0241-xx, Field Offset Adjustment Procedure for SLA and SLP Temperature and Humidity Outputs on [www.se.com/myschneider](http://www.se.com/myschneider) for further information. The offset functionality only exists on units containing a second DIP switch bank dedicated to the offset feature.

PM Sensor Negative Output Values in Current Mode

In certain circumstances where the atmosphere is very clean (approaching 0 µg/m<sup>3</sup>) and there is inherent noise in the measurement, negative values can be observed as reported by the PM sensor when used in current output mode.

Please note that in such specific conditions, the occurrence of negative values does not necessarily indicate an error. Instead, it can be a valid representation of the sensor’s response to very low particulate levels combined with measurement noise.

This sensor is designed to account for these nuances in environmental conditions, and the occasional observation of negative values within the specified range does not signify a malfunction.

### Installation (cont.)

- With sensor base fully installed, align top of cover to mounting tabs on top of sensor base. Swing cover downward until it latches at the bottom.



- Install locking screw to secure cover in closed position.



### PM Sensor Communication Check

During boot-up, the LED located on the right side of the unit will illuminate and then blink once if the PM sensor is properly connected. However, if the LED illuminates and then blinks five times at a quicker pace, this indicates a communication issue with the PM sensor leading to a steady 0µg/m<sup>3</sup> outputted value.

If the LED blinks due to a communication problem, the most likely cause is that the adapter board connecting the PM sensor to the main PCBA is disconnected. In this case, the adapter board should be pressed down to ensure its connection with the main PCBA.

On the next boot-up, ensure the LED is illuminated and then only blinking once, confirming the connection of the PM sensor.

### CO<sub>2</sub> Sensor Calibration (Touchscreen Models Only)

There are two methods for CO<sub>2</sub> calibration available: 400 ppm baseline calibration and automatic baseline calibration (ABC).

#### 400 ppm Baseline Calibration

400 ppm baseline calibration allows the sensor to be set at 400 ppm. Push and hold the calibration button for 3 to 5 seconds. The LED will flash green. Once the button is released, calibration is complete and the LED switches off.

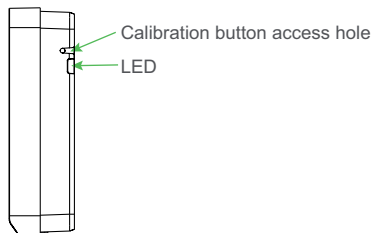

### Automatic Baseline Calibration (ABC)

The ABC mode addresses the 400 ppm calibration. It allows turning on or off a background correction/recovery mode that will minimize any calibration error that has been caused by shock during handling and transportation or is caused by a long term shift in measurement. The ABC algorithm constantly keeps track of the sensor's lowest reading over a preconfigured time interval and slowly corrects for any long-term drift detected as compared to the expected fresh air value of 400 ppm. After initial startup, it is expected that the sensor reaches specified accuracy after 7 to 21 days.

### Touchscreen Operation

#### Main Screen

The touchscreen user interface displays applicable sensor output values (temperature, RH, CO<sub>2</sub> and PM2.5), setpoint value, menu button and CO<sub>2</sub> stoplight status (if enabled).

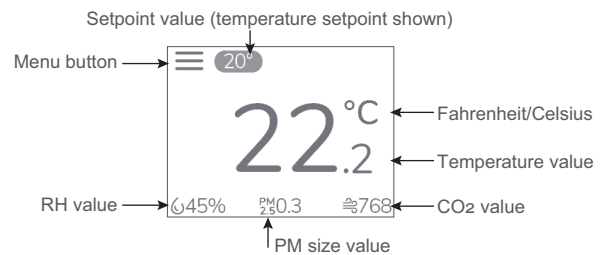

#### Menu Screen

The menu screen opens when pressing the Menu button on the main screen. Integrator's submenu, occupancy/override, Fahrenheit/Celsius, settings, setpoint submenu (temp, RH or fan, determined by DIP switch settings) and CO<sub>2</sub>/PM2.5 stoplight status buttons are displayed on the menu screen.

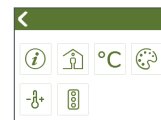

Temperature setpoint  
DIP switch selected



RH setpoint  
DIP switch selected

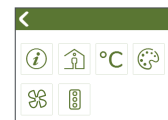



Fan Speed setpoint  
DIP switch selected

## Menu Button Functions

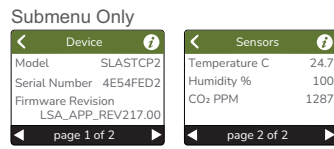
 **Integrator's Submenu**  
Press this icon to access the Integrator's menu.



 **Occupied Override Button**  
Press this icon to provide momentary ground output to the controller

Single Press Only  
 Signals occupied/override call to controller.

 **Fahrenheit/Celsius Switch**  
Press this icon to display either °C or °F.

Single Press Only

 Changes units to Fahrenheit when pressed.

 Changes units to Celsius when pressed.

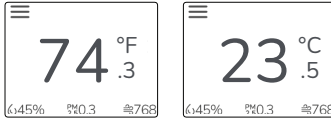

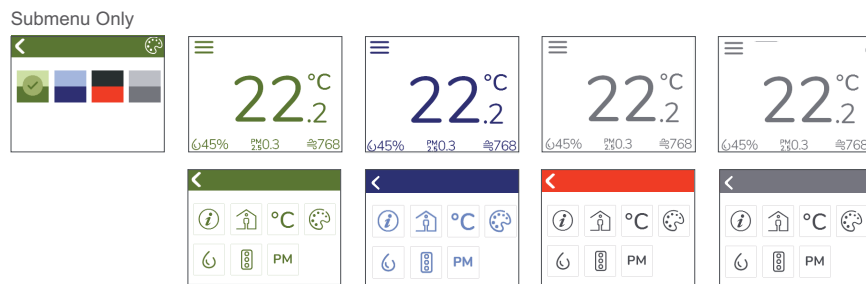

The image shows two screenshots of the Fahrenheit/Celsius Switch. The first screenshot shows the temperature in Fahrenheit (74.3) and the second screenshot shows the temperature in Celsius (23.5). Both screenshots also display humidity (45%) and CO2 (0.3 ppm).

 **Settings**  
This icon provides the ability to change the color scheme of the display.

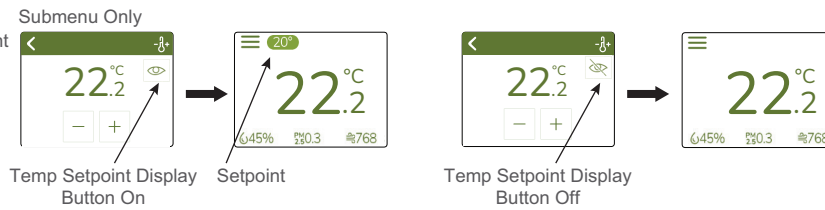

 **Temp Setpoint Adjustment**  
Click this icon to access the setpoint change menu. Mutually exclusive with fan speed. Set by DIP switch. Eye icon in upper right controls whether the setpoint is displayed. Eye open = setpoint displayed. Eye with strikethrough = setpoint not displayed.



 **Humidity Setpoint Adjustment**  
Click this icon to access the setpoint change menu. Mutually exclusive with humidity and fan speed. Set by DIP switch.

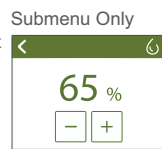

 **Fan Speed**  
Click this icon to access the fan speed menu.

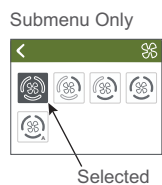

Menu Button Functions (cont.)

**CO<sub>2</sub>/PM Stoplight Menu**  
 Click this icon to toggle the Stoplight feature on and off. Scroll down by pressing the downward arrow.

With the Stoplight turned on, the area around the CO<sub>2</sub> and PM values at the bottom of the screen changes color. This provides a visual indicator of the CO<sub>2</sub> and PM levels to the room occupants.

Using the +/- buttons, the thresholds at which the colors change on the main screen are user configurable, as described in the diagram.

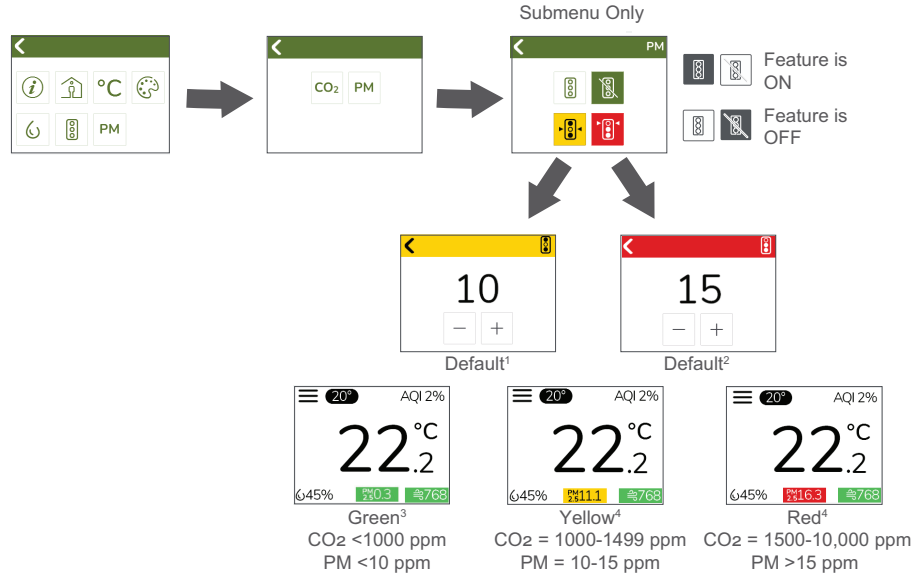

1. Values <400 ppm (resp. <4 µg/m<sup>3</sup>) will be rounded up to the minimum limit of 400 ppm (resp. 4 µg/m<sup>3</sup>).
2. Values >10,000 ppm (resp. >100 µg/m<sup>3</sup>) will be rounded up to the maximum limit of 10,000 ppm (resp. 100 µg/m<sup>3</sup>).
3. Possible to adjust PM and CO<sub>2</sub> thresholds by changing the yellow and red limits.
4. User configurable in increments using the +/- buttons. With a long press of these buttons, the number will change more quickly.

China RoHS Compliance Information  
 Environment-Friendly Use Period (EFUP) Table

部件名称	有害物质 - Hazardous Substances					
Part Name	铅 (Pb)	汞 (Hg)	镉 (Cd)	六价铬 (Cr (VI))	多溴联苯 (PBB)	多溴二苯醚 (PBDE)
电子件 Electronic	X	O	O	O	O	O

本表格依据SJ/T11364的规定编制。

O: 表示该有害物质在该部件所有均质材料中的含量均在GB/T 26572规定的限量要求以下。

X: 表示该有害物质至少在该部件的某一均质材料中的含量超出GB/T 26572规定的限量要求。

(企业可在此处，根据实际情况对上表中打“X”的技术原因进行进一步说明。)

This table is made according to SJ/T 11364.

O: indicates that the concentration of hazardous substance in all of the homogeneous materials for this part is below the limit as stipulated in GB/T 26572.

X: indicates that concentration of hazardous substance in at least one of the homogeneous materials used for this part is above the limit as stipulated in GB/T 26572

Z000057-0B

Schneider Electric Limited UK  
 Stafford Park 5 CA  
 Telford TF3 3BL  
 United Kingdom

USA: +1 888-444-1311  
 Europe: +46 10 478 2000  
 Asia: +65 6484 7877  
 www.schneider-electric.com

Life Is On

