



# CW2 Analog Series

## Wall Mount Air Quality Sensors

### Product Overview

The CW2 Series of air quality sensors for living space is a flexible multi-sensor platform for use with BAS controllers designed to accept 4 to 20mA, 0 to 5Vdc or 0 to 10Vdc outputs. CW2 Series sensors are available with three user interface options: touchscreen, LCD with three buttons and blank. CO2 and temperature sensors are included with all CW2 Series air quality sensors. Models with VOC sensors and relative humidity sensors are also available.

### Product Identification



**WARNING**

**HAZARD OF ELECTRIC SHOCK, EXPLOSION OR ARC FLASH**

- Apply appropriate personal protective equipment (PPE) and follow safe electrical work practices. See NFPA 70E or CSA Z462.
- This equipment must only be installed and serviced by qualified electrical personnel.
- Turn off all power supplying this equipment before working on or inside equipment.
- Always use a properly rated voltage sensing device to confirm power is off.
- Replace all devices, doors and covers before turning on power to this equipment.

**Failure to follow these instructions can result in death, serious injury or equipment damage.**

This product is intended for use in HVAC and building environmental control applications. It is not intended for direct medical monitoring of patients. It is not intended for life-safety applications. Read and understand these instructions before installing this product. The installer is responsible for all applicable codes. If this product is used in a manner not specified by the manufacturer, the protection provided by the product may be impaired. No responsibility is assumed by the manufacturer for any consequences arising out of the use of this material.

User Interface	Output	RH Accuracy <sup>1</sup>	Temperature	VOC Sensor
CW2 <input type="checkbox"/>	<input type="checkbox"/>	<input type="checkbox"/>	<input type="checkbox"/>	<input type="checkbox"/>
T = Color touchscreen L = 3-button LCD display X = None <sup>2</sup>	A = Analog output	2 = 2% X = None <sup>2</sup>	A = Transmitter C = 1000 PT RTD D = 10K T2 thermistor G = 10K CPC thermistor <sup>3</sup> H = 10K T3 thermistor K = 10K curve G/11K shunt M = 20K NTC thermistor N = 1.8K TAC thermistor	V = NDIR CO <sub>2</sub> /VOC <sup>4</sup> = None

1. Replaceable RH module available to be ordered separately per table below.
2. For analog non-display, non-RH models with RTD/thermistor, order from the CWE2 line.
3. Available in CW2LXG only.
4. VOC only available with temperature transmitter option.

### Replaceable RH Elements

Model	Description	Temp. Calibration	RH Calibration
HS1N	Replaceable RH sensor, 1% with NIST certificate	N/A	2-point calibration
HS2N	Replaceable RH sensor, 2% with NIST certificate	N/A	2-point calibration
HS2X	Replaceable RH sensor, 2%	N/A	2-point calibration

### Specifications

OPERATING ENVIRONMENT	
<b>Input Power</b>	Class 2; 20 to 30 Vdc, 24 Vac, 50 to 60 Hz
<b>Analog Output</b>	Selectable 4 to 20 mA, 0 to 5 V, 0 to 10 V
<b>Operating Temp. Range</b>	0 to 50 °C (32 to 122 °F)
<b>Operating Humidity Range</b>	0 to 95% RH non-condensing
<b>Housing Material</b>	High-impact ABS plastic
<b>Terminal Block Torque</b>	0.5 to 0.6 N-m (0.37 to 0.44 in-lbf)
<b>IP Rating</b>	IP 30
<b>Mounting Location</b>	For indoor use only. Not suitable for wet locations.
<b>Surface Mount</b>	The device can be surface mounted on Single Gang J-Box, British Standard and CE60 wall boxes

Specifications (cont.)

<b>CO<sub>2</sub> TRANSMITTER</b>			
<b>Sensor Type</b>	Non-dispersive infrared (NDIR), diffusion sampling		
<b>Output Range</b>	0 to 2,000/5,000 ppm (selectable)		
<b>Accuracy</b>	±30 ppm ±3% of measured value		
<b>Resolution</b>	1 ppm		
<b>Repeatability</b>	±20 ppm ±1% of measured value		
<b>Response Time</b>	<60 seconds for 90% step change		
<b>VOC TRANSMITTER OPTION</b>			
<b>Sensor Type</b>	Solid state		
<b>Output Range</b>	0 to 100% AQI for VOC		
<b>Accuracy</b>	±20% AQI		
<b>Resolution</b>	1 ppb		
<b>Output Scale</b>	0 to 5000 ppb of total VOC (TVOC)		
	<b>AQI % (Display)</b>	<b>TVOC Output (ppb)</b>	<b>Air Quality</b>
<b>AQI Table*</b>	100	>5319	Very Poor
	80 - 99	1596 - 5319	Poor
	60 - 79	532 - 1596	Moderate
	40 - 59	160 - 532	Good
	0 - 39	≤160	Very Good
<b>RH TRANSMITTER OPTION</b>			
<b>Sensor Type</b>	Solid state capacitive, replaceable		
<b>Output Range</b>	0 to 100% RH		
<b>Accuracy (Includes Hysteresis)**</b>	±3.8% RH from 10 to 60% RH @ 25°C (77 °F) ±4.8% RH from 60 to 80% RH @ 25°C (77 °F) ±5.8% RH from 80 to 100% RH @ 25°C (77 °F)		
<b>Resolution</b>	0.1% RH		
<b>Hysteresis</b>	1.5% typical		
<b>Stability</b>	±1% @ 20°C (68 °F) annually for 2 years		
<b>Temperature Coefficient</b>	±0.1% RH/°C above or below 25 °C (77 °F) typical		
<b>TEMPERATURE TRANSMITTER OPTION</b>			
<b>Sensor Type</b>	Solid state, integrated circuit		
<b>Output Range</b>	0 to 50 °C (32 to 122 °F)		
<b>Accuracy</b>	±0.2 °C (±0.4 °F) typical		
<b>Resolution</b>	0.1 °C (0.1 °F)		
<b>DISPLAY MODELS</b>			
<b>Touchscreen</b>	61 mm (2.4 in), color, backlit, capacitive, 240x300 px Setpoint: 0-10Vdc. Temperature, humidity or fan speed selectable Timeout override: Display timeout*** Lockout override: Touchscreen/button lockout***		
<b>LCD</b>	52mm (2.05 in), segmented with 3 buttons Setpoint: 0-10Vdc. Temperature, humidity or fan speed selectable Timeout override: Display timeout*** Lockout override: Touchscreen/button lockout***		
<b>SETPOINTS****</b>			
<b>Temperature Setpoint</b>	0 to 10V output Scale: 10 to 35 °C (50 to 95 °F) / 0 to 50 °C (32 to 122 °F)		
<b>Humidity Setpoint</b>	0 to 10V output Scale: 0 to 100% RH		

## Specifications (cont.)

<b>Fan Speed Setpoint</b>	0 to 10V output Off 0V, Auto 1.5V, Low 3.3V, Med. 6.7V, High 10.0V
<b>OVERRIDE</b>	
<b>Override Button</b>	Display models feature a momentary-to-ground override button
<b>WIRING TERMINALS</b>	
<b>Terminal Blocks</b>	Screw terminals, 18-24 AWG
<b>Screw Terminal Torque</b>	0.2 N-m (2.0 in-lbF) max.
<b>WARRANTY</b>	
<b>Limited Warranty</b>	5 years
<b>COMPLIANCE INFORMATION</b>	
<b>Agency Approvals</b>	UL 916 European Conformance CE: EN 60730-1, EN 60730-2-9, EN 60730-2-13, EN 61000-6-2, EN 61000-6-3, EN 61000 Series - Industrial Immunity, EN 61326-1 FCC Part 15 Class B, REACH, RoHS, ICES-003 (Canada), UKCA (UK)

\* Based on TVOC levels described by UBA.

\*\* Humidity sensor overall accuracy should include: accuracy, temperature coefficient and stability. Humidity accuracy is shown as an absolute value, so if testing accuracy with a hand-held device, you must check for deviation in its readings instead of calculating the percentual deviation. Additionally, you must consider the overall accuracy of the hand-held device in the comparison.

\*\*\* DIP switch selectable.

\*\*\*\* One setpoint type is selectable via DIP switch on display models only.

## Dimensions

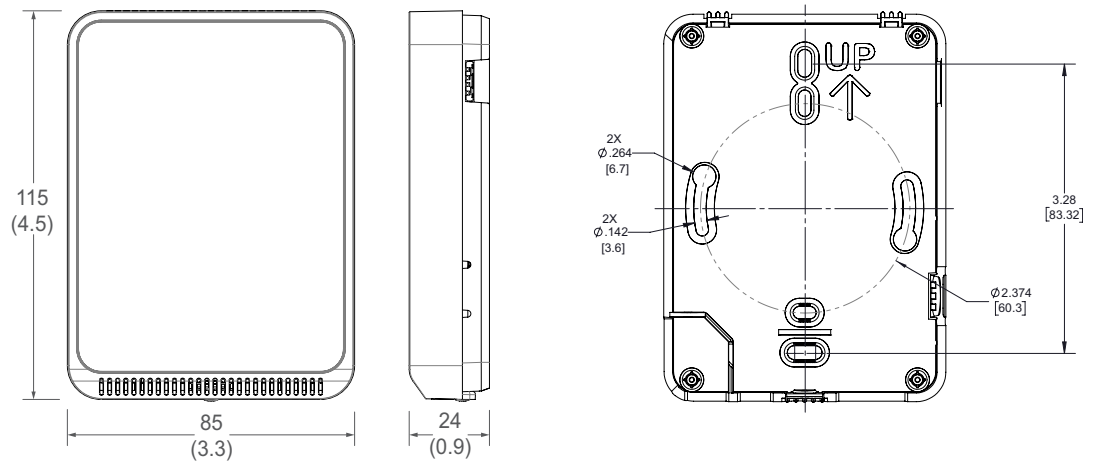

## Functions

The CW2 Series sensor measures CO<sub>2</sub>, VOC (if equipped), RH (if equipped) and temperature in a room and provides analog outputs to a controller.

## Installation

### NOTICE

#### PRODUCT DAMAGE AND INACCURATE READINGS

- Mount product vertically at a height that is between 3 to 5 feet (0.9 to 1.5 meters) above the floor [or 4 feet (1.2 meters) where the Americans with Disabilities Act needs to be followed]
- Mount product on a wall that is NOT exposed to the outside
- Install product far from windows, heat sources, door frames and at a minimum distance of 6 inches (15 centimeters) from any corner
- Drafts through conduits or other holes in the wall should be eliminated by plugging appropriate material into the cavity.
- This product is specified for environments with stable natural airflow. In dynamic airflow conditions, sensor performance may deviate from expected values. In stable elevated airflow, an offset feature can be applied. Refer to ZL0240-xx, CW2, HW2, TW2 and PMW Living Space Products *Field Offset Adjustment Procedure for Temperature and Humidity Outputs* on [www.veris.com](http://www.veris.com) for further information. The offset functionality only exists on units containing a second DIP switch bank dedicated to the offset feature.
- Keep product wall mounted base cleared from any wire or other external material:

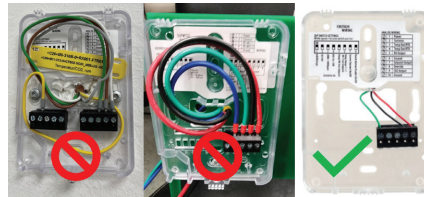

**Failure to follow instructions can result in reduced accuracy, equipment damage or sensor fault.**

1. Remove the cover from the base at the bottom of the device.



2. Position the sensor base vertically on the wall 1.35 m (4.5 ft.) above the floor with the "UP" arrow facing upward. Locate away from windows, vents and other sources of draft. If possible, do not mount on an external wall, as this may cause inaccurate temperature readings.



3. Pull 18 or 22 AWG cable(s) through the hole in the backplate.

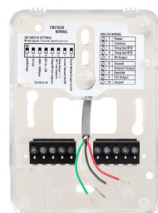

## Installation (cont.)

4. Mount the backplate onto the wall using the screws provided.

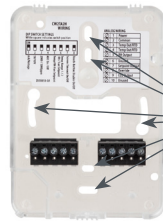

Six screw holes available. Use a minimum of two for secure mounting.

5. Connect the wires to the screw terminals. Do not over-tighten the screws.



Wiring for models with temperature transmitter:

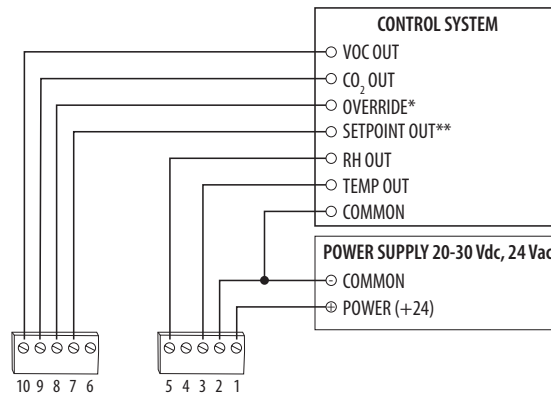

Wiring for models with RTD/thermistor:

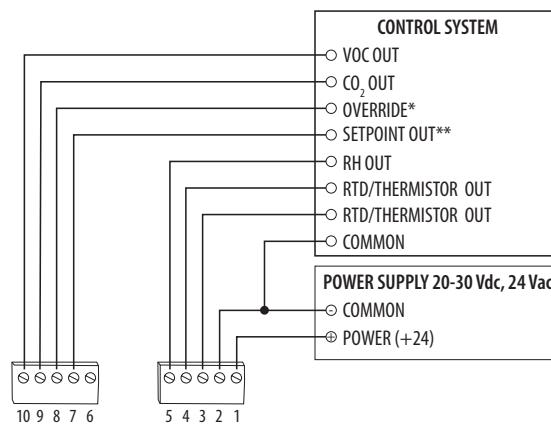

\* Momentary to ground.

\*\* 0-10V DIP switch selectable for temperature, RH (if equipped) or fan speed (off, 0V, Auto 1.5V, Low 3.3V, Medium 6.7V or high 10V).

Installation (cont.)

6. Set the left DIP switch.

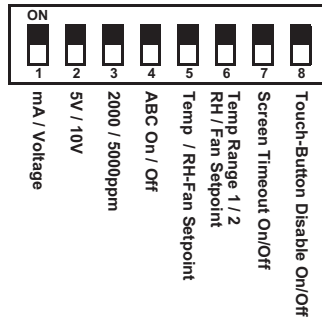

Switch	Function	Description
1	Output mode	ON - 4-20mA output mode enabled OFF - Voltage output mode enabled
2	Voltage output range*	ON - 0-5V output range enabled OFF - 0-10V output range enabled
3	CO <sub>2</sub> output range	ON - 0-2000 ppm CO <sub>2</sub> output range enabled OFF - 0-5000 ppm CO <sub>2</sub> output range enabled
4	Automatic Baseline Calibration (ABC) for CO <sub>2</sub>	ON - ABC enabled OFF - ABC disabled
5	Setpoint output type	ON - Temperature setpoint enabled (temp range selected on DIP switch 6) OFF - RH or Fan Speed setpoint enabled (specific setpoint output type to be selected on DIP switch 6) Models without RH option select only temp or fan setpoint
6	Setpoint output temperature range or RH/Fan Speed output type	Temperature setpoint (must be enabled on DIP switch 5) ON - Temp range 1, 50 to 95 °F (10 to 35 °C) enabled OFF - Temp range 2, 32 to 122 °F (0 to 50 °C) enabled
		RH or Fan Speed setpoint (must be enabled on DIP switch 5) ON - RH setpoint enabled OFF - Fan Speed setpoint enabled Models without RH option, set to OFF
7	Display times out and turns off after 6-10 seconds of touchscreen/button press	ON - Display Timeout enabled OFF - Display Timeout disabled
8	Touchscreen touch functions and buttons are disabled	ON - Touchscreen touch/button functions disabled OFF - Touchscreen touch/button functions enabled

\* Only used with voltage output mode enabled. Not applicable to setpoint output. Setpoint is 0-10V fixed.

Note: There is a second DIP switch bank dedicated to the offset feature that allows local adjustments to counterbalance settings that may be affected by sensor location. For more information, see ZL0240, CW2, HW2, TW2 and PMW Living Space Products Field Offset Adjustment Procedure for Temperature and Humidity Outputs available on the Veris website at [www.veris.com](http://www.veris.com). The offset functionality only exists on units containing a second DIP switch bank dedicated to the offset feature.

7. With sensor base fully installed, align top of cover to mounting tabs on top of sensor base. Swing cover downward until it latches at the bottom.



## Installation (cont.)

8. Install locking screw to secure cover in closed position.



## CO2 Sensor Calibration

There are two methods for CO2 calibration available: 400 ppm baseline calibration and automatic baseline calibration (ABC).

### 400 ppm Baseline Calibration

400 ppm baseline calibration allows the sensor to be set at 400 ppm. Push and hold the calibration button for 3 to 5 seconds. The LED will flash green. Once the button is released, calibration is complete and the LED switches off.

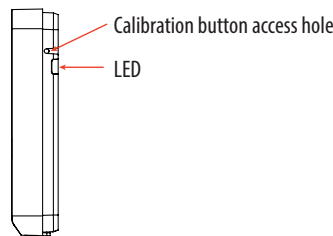

### Automatic Baseline Calibration (ABC)

The ABC mode addresses the 400 ppm calibration. It allows turning on or off a background correction/recovery mode that will minimize any calibration error that has been caused by shock during handling and transportation or is caused by a long term shift in measurement. The ABC algorithm constantly keeps track of the sensor's lowest reading over a preconfigured time interval and slowly corrects for any long-term drift detected as compared to the expected fresh air value of 400 ppm. After initial startup, it is expected that the sensor reaches specified accuracy after 7 to 21 days.

## Touchscreen Operation

### Main Screen

The touchscreen user interface displays applicable sensor output values (temperature, RH, CO2 and VOC), setpoint value, menu button and CO2 stoplight status (if enabled).

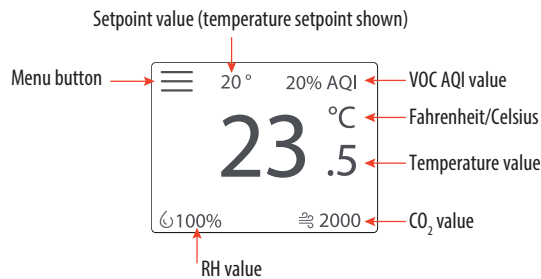

### Menu Screen

The menu screen opens when pressing the Menu button on the main screen. Integrator's submenu, occupancy/override, Fahrenheit/Celsius, settings, setpoint submenu (temp, RH or fan, determined by DIP switch settings) and CO2 stoplight buttons are displayed on the menu screen.

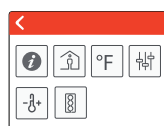

Temperature setpoint  
DIP switch selected

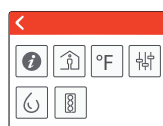

RH setpoint  
DIP switch selected

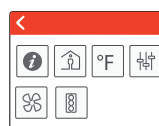

Fan Speed setpoint  
DIP switch selected

## Touchscreen Operation (cont.)

### Menu Button Functions

**Integrator's Submenu**  
Press this icon to access the Integrator's menu.

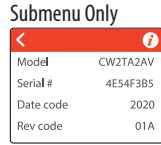

**Occupied Override Button**  
Press this icon to provide momentary ground output to the controller

Single Press Only  
 Signals occupied/override call to controller.

**Fahrenheit/Celsius Switch**  
Press this icon to display either °C or °F.

Single Press Only  
 Changes units to Fahrenheit when pressed.  
 Changes units to Celsius when pressed.

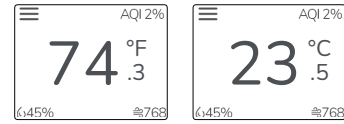

**Settings**  
This icon provides the ability to change the color scheme of the display.

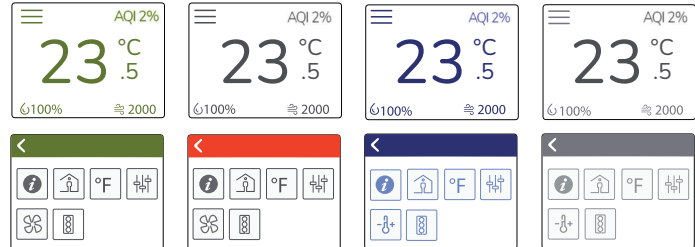
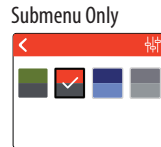

**Temp Setpoint Adjustment**  
Click this icon to access the setpoint change menu. Toggle the Temp Setpoint Display button to display or hide the setpoint value on the home screen.

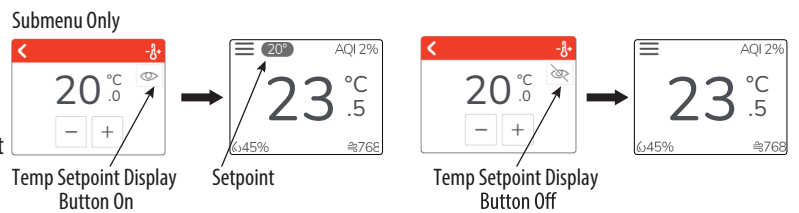

**Humidity Setpoint Adjustment**  
Click this icon to access the setpoint change menu. Mutually exclusive with humidity and fan speed. Set by DIP switch.

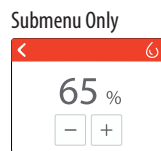

**Fan Speed**  
Click this icon to access the fan speed menu. Mutually exclusive with humidity and fan speed. Set by DIP switch.

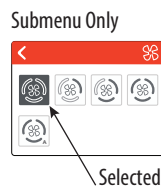

## Touchscreen Operation (cont.)



### CO2 Stoplight Menu

Click this icon to toggle the CO2 Stoplight feature on and off. With CO2 Stoplight turned on, the background color of the main screen changes with CO2 level. This provides a visual indicator of CO2 levels to the room occupants.

Using the +/- buttons, the thresholds at which the colors change on the main screen are user configurable, as described in the diagram.

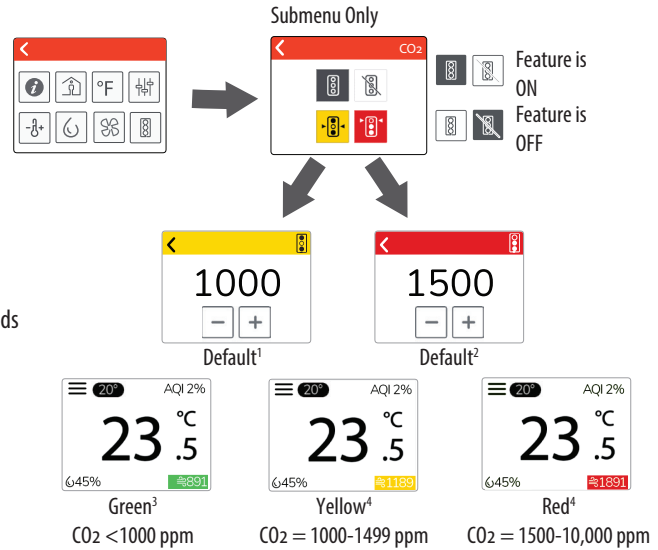

1. Values <400 ppm will be rounded up to the minimum limit of 400 ppm.
2. Values >10,000 ppm will be rounded down to the maximum limit of 10,000 ppm.
3. Possible to adjust CO2 thresholds by changing the yellow and red limits.
4. User configurable in increments of 10 ppm using the +/- buttons. With a long press of these buttons, the number will change more quickly.

## LCD Display Operation

### Button Functions

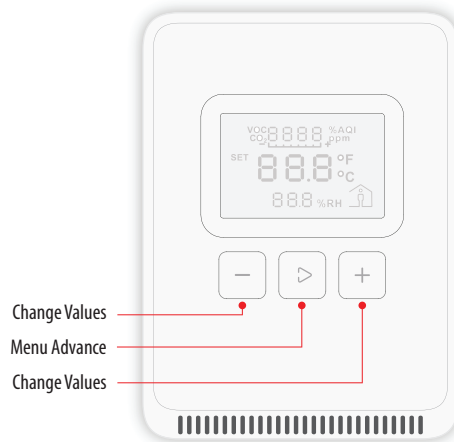

### Display Icons

The main screen displays sensor values for CO2, VOC (if equipped), RH (if equipped), temperature and Celsius/Fahrenheit.

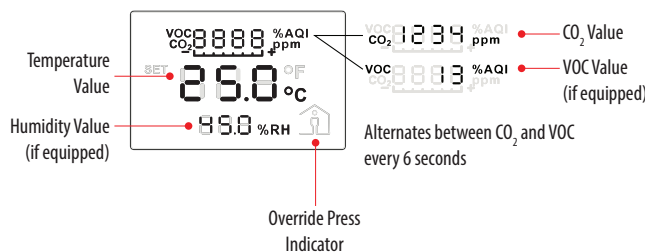

## Setpoint Function

A single 0-10V setpoint (temperature, RH (if equipped) or fan speed) can be selected via DIP switch.

### Temperature Setpoint Adjustment

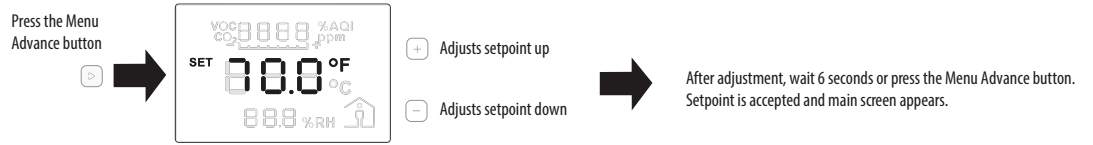

Note: Numeric information will flash while in Set mode.

### RH Setpoint Adjustment

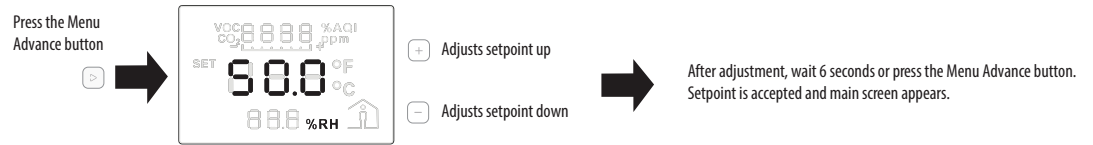

Note: Numeric information will flash while in Set mode.

### Fan Speed Setpoint Adjustment

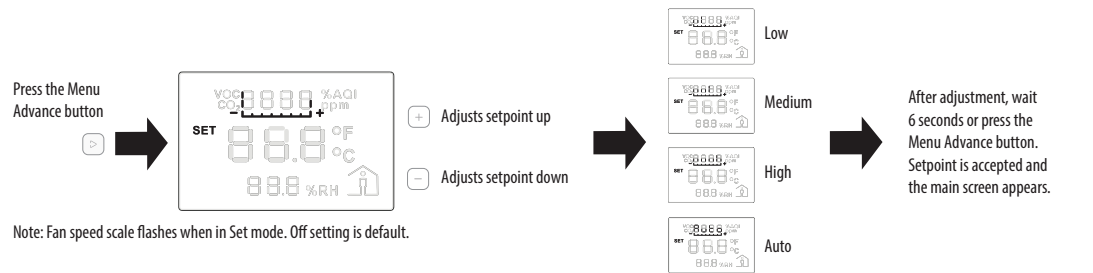

Note: Fan speed scale flashes when in Set mode. Off setting is default.

### Changing Celsius and Fahrenheit Scales

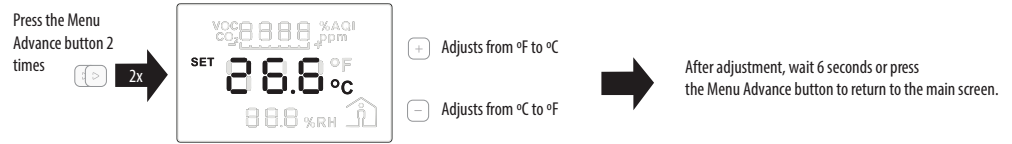

Note: °F or °C text will flash while in Set mode.

### Occupied/Override Button

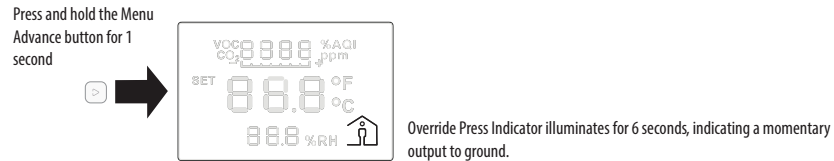

## China RoHS Compliance Information

*Environment-Friendly Use Period (EFUP) Table*

部件名称	有害物质 - Hazardous Substances					
Part Name	铅 (Pb)	汞 (Hg)	镉 (Cd)	六价铬 (Cr (VI))	多溴联苯 (PBB)	多溴二苯醚 (PBDE)
电子件 Electronic	X	O	O	O	O	O

本表格依据SJ/T11364的规定编制。

O: 表示该有害物质在该部件所有均质材料中的含量均在GB/T 26572规定的限量要求以下。

X: 表示该有害物质至少在该部件的某一均质材料中的含量超出GB/T 26572规定的限量要求。

(企业可在此处，根据实际情况对上表中打“X”的技术原因进行进一步说明。)

This table is made according to SJ/T 11364.

O: indicates that the concentration of hazardous substance in all of the homogeneous materials for this part is below the limit as stipulated in GB/T 26572.

X: indicates that concentration of hazardous substance in at least one of the homogeneous materials used for this part is above the limit as stipulated in GB/T 26572

Z000057-0B