

# EM35xx Series

Compact Power and Energy Meters  
(Pulse, Modbus, BACnet)

Quick Installation Guide  
Z206079-0F  
1121

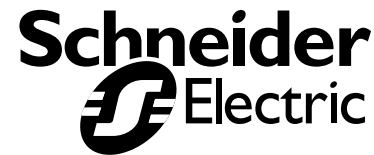

Excerpts: for additional information, please refer to the full installation guide at [www.se.com](http://www.se.com)

**⚠️ ⚠️ DANGER**

**HAZARD OF ELECTRIC SHOCK, EXPLOSION, OR ARC FLASH**

- Follow safe electrical work practices. See NFPA 70E in the USA, CSA Z462 in Canada, or applicable local codes.
- Read and understand the instructions before installing the product. Follow the instructions during installation.
- Installation, wiring, testing or service must be performed only by qualified persons in accordance with all applicable codes and regulations.
- Install the product in an appropriate electrical and fire enclosure per local regulations.
- Do not use the product for life or safety applications.
- Do not install the product in hazardous or classified locations.
- Do not exceed the product's ratings or maximum limits.
- The product may use multiple voltage/power sources.
- Turn off ALL power supplying equipment before working on or inside the equipment.
- Use a properly rated voltage sensing device to confirm that all power is off.
- Do NOT depend on the product for voltage indication.
- Products rated only for basic insulation must be installed on insulated conductors.
- Current transformer secondaries (current mode) must be shorted or connected to a burden at all times.
- Remove all wire scraps and tools, replace all doors, covers and protective devices before powering the equipment.

**Failure to follow these instructions will result in death or serious injury.**

A qualified person is one who has skills and knowledge related to the construction and operation of this electrical equipment and installations, and has received safety training to recognize and avoid the hazards involved. NEC Article 100

If this product is used in a manner not specified by the manufacturer, the protection provided by the product may be impaired. No responsibility is assumed by the manufacturer for any consequences arising out of the use of this material.

The safety of any system incorporating this equipment is the responsibility of the assembler of the system.

**WARNING: LOSS OF CONTROL.** Networked devices can interfere with critical control functions. Refer to NEMA ICS 1.1 (latest edition). *Safety Guidelines for the Application, Installation, and Maintenance of Solid-State Controls* or its equivalent in your country, language, and/or location. **Provide a device to disconnect this product from the supply.** Place it in close, easy reach of the product, and mark it as the disconnecting device. The device shall meet IEC 60947-1 and IEC 60947-3 and be suitable for the application. In the US and Canada, disconnecting fuse holders can be used. Provide overcurrent protection for supply conductors with approved current limiting devices suitable to protect the wiring.

**For use in an Installation Category III or II, Pollution Degree 2 or better environment only.** See full install for definitions.

**FCC PART 15 INFORMATION**  
NOTE: This equipment has been tested by the manufacturer and found to comply with the limits for a class B digital device, pursuant to part 15 of the FCC Rules. These limits are designed to provide reasonable protection against harmful interference when the equipment is operated in a residential environment. This equipment generates, uses, and can radiate radio frequency energy and, if not installed and used in accordance with the instruction manual, may cause harmful interference to radio communications. This device complies with part 15 of the FCC Rules. Operation is subject to the following two conditions:  
(1) This device may not cause harmful interference, and  
(2) this device must accept any interference received, including interference that may cause undesired operation.

Modifications to this product without the express authorization of the manufacturer nullify this statement.

## Specifications

Measurement Accuracy:	Real Power & Energy IEC 62053-22 Class 0.2S, ANSI C12.20 0.2%
Input Voltage Characteristics:	Measured AC Voltage Minimum 90 V <sub>L-N</sub> (156 V <sub>L-L</sub> ) for stated accuracy; UL Maximums: 600 V <sub>L-L</sub> (347 V <sub>L-N</sub> ); CE Maximum: 300 V <sub>L-N</sub>
Impedance	2.5 MΩ <sub>L-N</sub> / 5 MΩ <sub>L-L</sub>
Frequency Range	45 to 65 Hz
Input Current Characteristics:	Measurement Input Range 0 to 0.333 VAC or 0 to 1.0 VAC (+20% over-range)
Impedance	10.6 kΩ (1/3 V mode) or 32.1 kΩ (1 V mode)
Control Power:	AC 5 VA max.; 90 V min. UL Maximums: 600 V <sub>L-L</sub> (347 V <sub>L-N</sub> ) CE Maximum: 300 V <sub>L-N</sub> DC* 3 W max.; UL and CE: 125 to 300 VDC
Ride Through Time	100 msec at 120 VAC
Mechanical Characteristics:	IP40 front display; IP20 Meter
IP Degree of Protection (IEC 60529)	Terminal Block Screw Torque 0.37 ft-lb (0.5 N·m) nominal 0.44 ft-lb (0.6 N·m) max.
Terminal Block Wire Size	14 to 24 AWG (0.2 to 2.1 mm <sup>2</sup> )
Rail	T35 (35 mm) DIN Rail per EN 50022
Environmental Conditions:	Operating Temperature -30° to 70°C (-22° to 158°F)
Storage Temperature	-40° to 85°C (-40° to 185°F)
Humidity Range	<95% RH (non-condensing)
Altitude of Operation	3 km max.
Mounting Location	Not suitable for wet locations. For indoor use only.
Metering Category:	North America CAT III; for distribution systems up to 347 V <sub>L-N</sub> / 600 VAC <sub>L-L</sub>
CE	CAT III; for distribution systems up to 300 V <sub>L-N</sub>
Dielectric Withstand	Per UL 508, IEC/EN 61010-1
Conducted and Radiated Emissions	FCC part 15 Class B, EN 55011/ EN 61000 Class B (residential and light industrial)
Conducted and Radiated Immunity	EN 61000 Class A (heavy industrial)
Agency Approvals:	US and Canada (cULus) UL 508 (open type device)/CSA 22.2 No. 14-05
Europe (CE)	IEC/EN 61010-1

\* External DC current limiting is required, see fuse recommendations.

## Dimensions

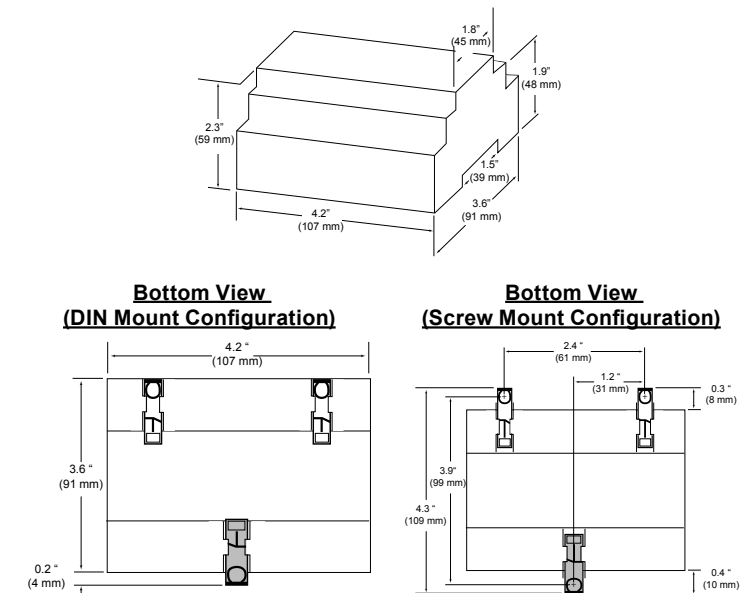

## Product Identification

EM35xx:

- 02 = Unidirectional metering, pulse and alarm outputs only
- 50 = Unidirectional metering, Modbus full data set, pulse and alarm outputs
- 55 = Bidirectional metering, Modbus full data set, data logging, pulse and alarm outputs
- 60 = Unidirectional metering, BACnet full data set, data logging, and two pulse inputs
- 61 = Unidirectional metering, BACnet full data set, one alarm output, and one pulse input

## Installation

The meter can be mounted in two ways: on standard 35 mm DIN rail or screw-mounted to the back of the enclosure.

### A. DIN Rail Mounting

- Disconnect and lock out power. Use a properly rated voltage sensing device to confirm power is off.
- Attach mounting clips to the underside of the housing by sliding them into the slots from the inside. The stopping pegs must face the housing, and the outside edge of the clip must be flush with the outside edge of the housing.
- Snap the clips onto the DIN rail. See diagram of the underside of the meter.
- To prevent horizontal shifting across the DIN rail, use two end stop clips.

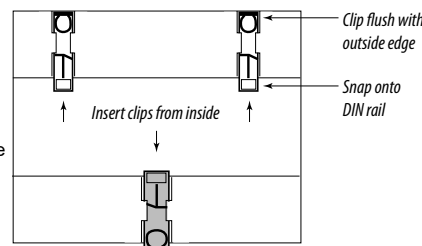

### B. Screw Mounting

- Disconnect and lock out power. Use a properly rated voltage sensing device to confirm power is off.
- Attach the mounting clips to the underside of the housing by sliding them into the slots from the outside. The stopping pegs must face the housing, and the screw hole must be exposed on the outside of the housing.
- Use three #8 screws (not supplied) to mount the meter to the back of the enclosure. See diagram of the underside of the meter.

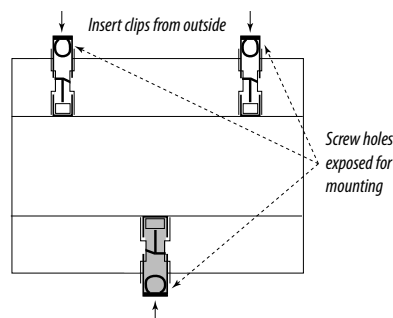

## Supported System Types

Num. of wires	CTs		Voltage Connections			System Type		Phase Loss Measurements			Wiring Diagram
	Qty	ID	Qty	ID	Type	Modbus Register 130 or BACnet Analog Value object AV2	User Interface: SETUP> S SYS	VLL	VLN	Balance	
<b>Single-Phase Wiring</b>											
2	1	A	2	A, N	L-N	10	1L + 1n		AN		1
2	1	A	2	A, B	L-L	11	2L	AB			2
3	2	A, B	3	A, B, N	L-L with N	12	2L + 1n	AB	AN, BN	AN-BN	3
<b>Three-Phase Wiring</b>											
3	3	A, B, C	3	A, B, C	Delta	31	3L	AB, BC, CA		AB-BC-CA	4
4	3	A, B, C	4	A, B, C, N	Grounded Wye	40	3L + 1n	AB, BC, CA	AN, BN, CN	AN-BN-CN & AB-BC-CA	5, 6

To avoid distortion, use parallel wires for control power and voltage inputs.

The following symbols are used in the wiring diagrams on the following pages.

Symbol	Description
	Voltage Disconnect Switch
	Fuse (installer is responsible for ensuring compliance with local requirements. No fuses are included with the meter.)
	Earth ground
	Current Transducer
	Potential Transformer
	Protection device containing a voltage disconnect switch with a fuse or disconnect circuit breaker. The protection device must be rated for the available short-circuit current at the connection point.

## NOTICE

**RISK OF EQUIPMENT DAMAGE**  
This product is designed only for use with 1 V or 0.333 V current transducers (CTs).  
• **DO NOT USE CURRENT OUTPUT (e.g. 5A) CTs ON THIS PRODUCT.**  
**Failure to follow these instructions can result in overheating and permanent equipment damage.**

## Product Diagram

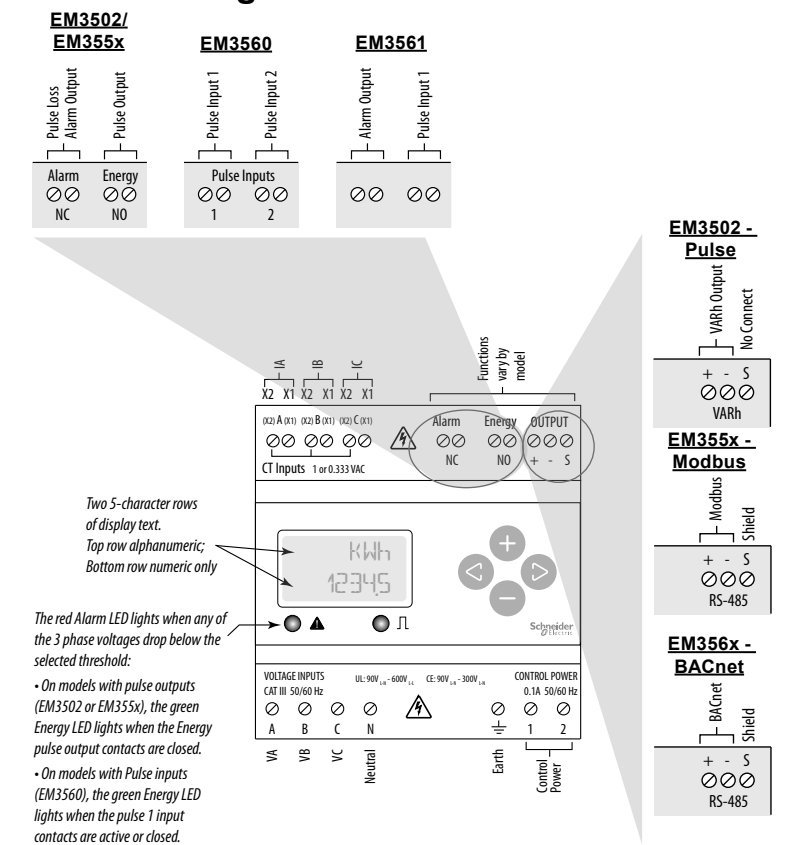

## Wiring

⚠️ ⚠️ WARNING

**RISK OF ELECTRIC SHOCK OR PERMANENT EQUIPMENT DAMAGE**

CT terminals are referenced to the meter's neutral and may be at elevated voltages:

- Do not contact meter terminals while the unit is connected.
- Do not connect or short other circuits to the CT terminals.

**Failure to follow these instructions may cause injury, death or equipment damage.**

For EM3502, EM3550, EM3560, and EM3561 models, CTs are NOT polarity sensitive. No need to observe orientation. For EM3555 model, CTs are polarity sensitive. Observe correct orientation as shown below.

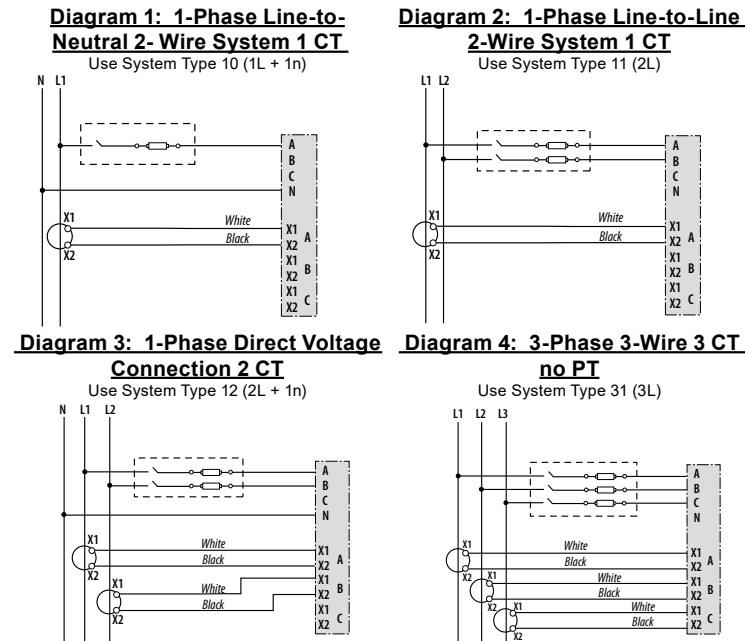

Page 9

## Diagram 5: 3-Phase 4-Wire Wye Direct Voltage Input Connection 3 CT

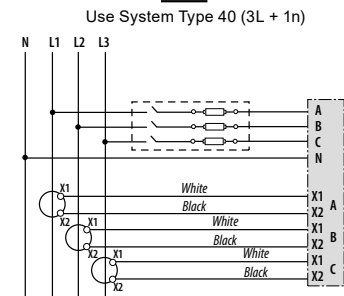

## Diagram 6: 3-Phase 4-Wire Wye Connection 3 CT 3 PT

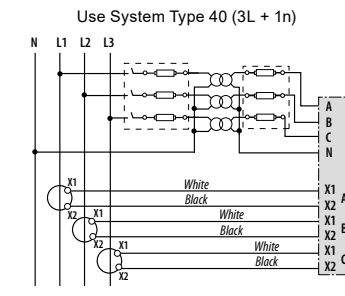

## Control Power

### Direct Connect Control Power (Line to Line)

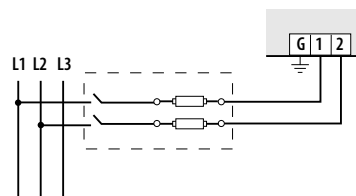

Line to Line from 90 VAC to 600 VAC (UL). In UL installations the lines may be floating (such as a delta). If any lines are tied to an earth (such as a corner grounded delta), see the Line to Neutral installation limits. In CE compliant installations, the lines must be neutral (earth) referenced at less than 300 VAC<sub>L-N</sub>.

Page 10

### Direct Connect Control Power (Line to Neutral)

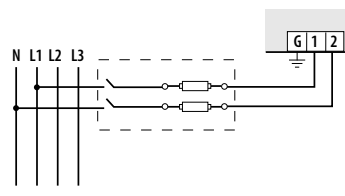

Line to Neutral from 90 VAC to 347 VAC (UL) or 300 VAC (CE)

## Direct Connect Control Power (DC Control Power) Control Power Transformer (CPT) Connection

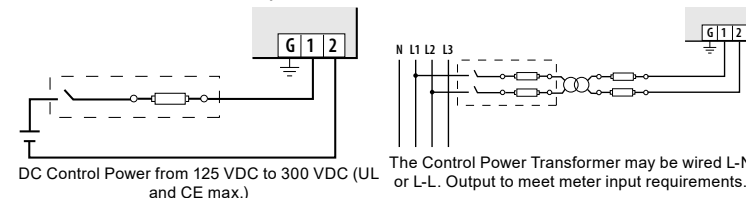

### Fuse Recommendations:

- Keep the fuses close to the power source (obey local and national code requirements). For selecting fuses and circuit breakers, use the following criteria:
- Select current interrupt capacity based on the installation category and fault current capability.
  - Select over-current protection with a time delay.
  - Use a voltage rating sufficient for the input voltage applied.
  - Provide overcurrent protection and disconnecting means to protect the wiring. For DC installations, provide external circuit protection. Suggested: 0.5A, time delay fuses rated for DC operations at or above the supply voltage.
  - Use the earth connection (G) for electromagnetic compatibility (EMC), not a protective earth ground.

## Pulse Contact Inputs (EM356x Only)

The EM3560 has two inputs with pulse accumulators for solid state or mechanical contacts in other sensors, such as water or gas flow meters. The EM3561 has one pulse input. These inputs are isolated from the measured circuits and referenced to the communication output shield terminal. Use with contacts that do not require current to remove oxidation.

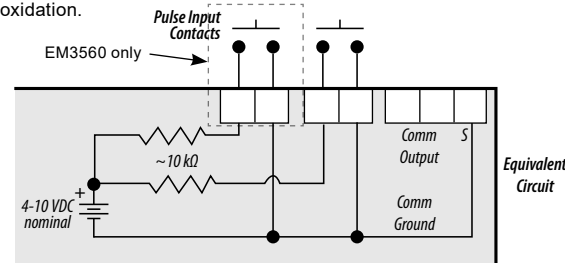

Page 11

## Solid State Pulse Output (EM3502 and EM355x Only)

The EM3502 and EM355x have one normally open (N.O.) KY Form A output and one normally closed (N.C.) output. One is dedicated to energy (Wh), and the other to Alarm. The EM3502 also provides an additional (N.O.) reactive energy (VARh) contact. See the Setup section for configuration information.

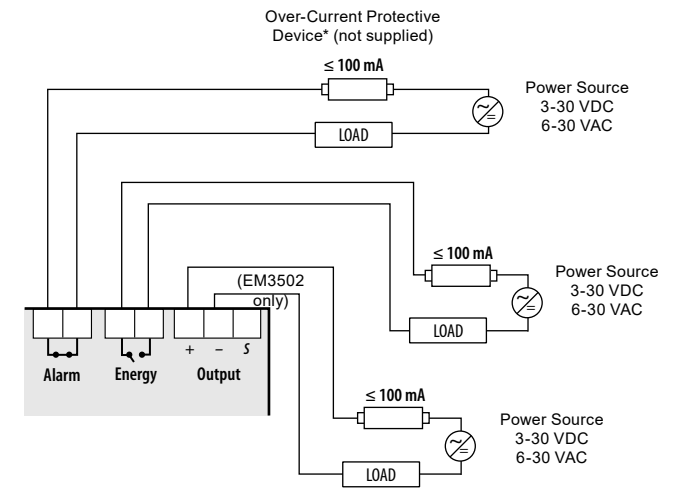

The solid state pulse outputs are rated for 30 VAC/DC nom. Maximum load current is 100 mA at 25°C. Derate 0.56 mA per °C above 25°C (e.g. 86 mA@50°C). \* The over-current protective device must be rated for the short circuit current at the connection point. \*\* All pulse outputs and communication circuits are only intended to be connected to non-hazardous circuits (SELV or Class 2). Do not connect to hazardous voltages.

Page 12

## RS-485 Communications (EM355x and EM3560 Only)

Daisy-chaining Devices to the Power Meter  
The RS-485 slave port allows the power meter to be connected in a daisy chain with up to 63 2-wire devices.

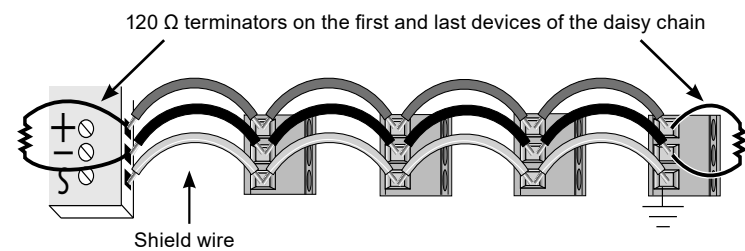

### Notes:

- The terminal's voltage and current ratings are compliant with the requirements of the EIA RS-485 communications standard.
- The RS-485 transceivers are ¼ unit load or less.
- RS-485+ has a 47 kΩ pull up to +5V, and RS-485- has a 47 kΩ pull down to Shield (RS-485 signal ground).
- Wire the RS-485 bus as a daisy chain from device to device, without any stubs. Use 120 Ω termination resistors at each end of the bus (not included).
- Shield is not internally connected to Earth Ground.
- Connect Shield to Earth Ground somewhere on the RS-485 bus.
- Use 14-24 gauge (2.1 to 0.2 mm<sup>2</sup>) wire for all connections.
- When tightening terminals, apply the correct torque: 0.37 to 0.44 ft-lb (0.5 to 0.6 N·m).

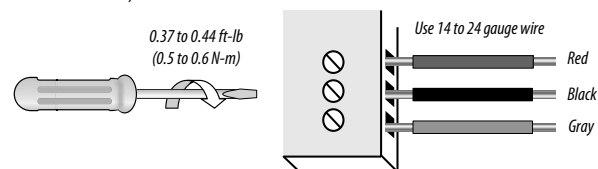

Page 13

## Display Screen Diagram

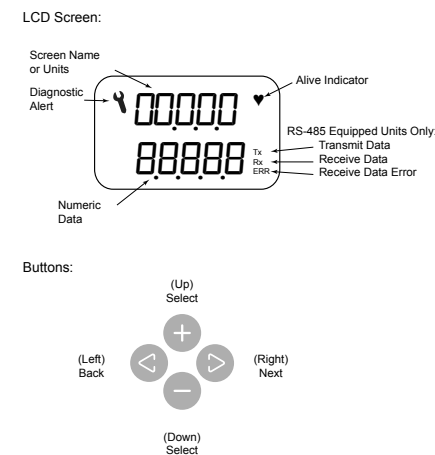

## Initial Setup Instructions

These instructions assume the meter is set to factory defaults. If it has been previously configured, check all optional values. For more options and the full setup instructions, see the full installation guide for the specific model.

### A. To Navigate to the Setup screens:

- Press **+** or **-** repeatedly until SETUP screen appears.
- Press **→** to get to the PASSWORD screen.
- Press **→** to move through the digits. Use the **+** or **-** buttons to enter your password (the default is 00000).
- Press **→** to move to the first Setup screen (5 CT on EM3502, 5 CT on EM355x, 5 BRC on EM356x)
- Use **+** or **-** to select the parameter screen you want to set.
- After you set the parameters you want, use **+** or **-** to select the next Setup screen or **→** to exit the Setup screens (return to SETUP).

Page 14

### B. To Enter Modbus communication parameters (EM355x models only):

- Navigate to the 5 COM (set communications) Setup screen (see section A).
- Press **→** to go to the ADDR screen and through the address digits. Use **+** or **-** to select the Modbus address (default is 00).
- Press **→** to accept the value and go to the BAUD screen. Use **+** or **-** to select the baud rate (default is 19200).
- Press **→** to go to the PAR screen. Use **+** or **-** to select the parity (default is EVEN).
- Press **→** to go back to the 5 COM screen.

### C. To Enter BACnet communication parameters (EM356x models only)

- Navigate to the 5 BRC (set BACnet) Setup screen (see section A).
- Press **→** to go to the MAC screen and through the address digits. Use **+** or **-** to select the BACnet MAC address (default is 00).
- Press **→** to accept the value and go to the KBAUD screen. Use **+** or **-** to select the baud rate (default is 16.8K).
- Press **→** to go to the ID1 screen and through the upper four digits of the Device Instance. Use **+** or **-** to select the ID digits (default is a pseudo-random number).
- Press **→** to accept the value and go to the ID2 screen and through the lower three digits of the Device Instance. Use **+** or **-** to select the ID digits (default is a pseudo-random number).
- Press **→** to accept the value and go back to the 5 BRC screen.

### D. To Enter the CT (Current Transducer) output voltage and input current ranges:

- Navigate to the 5 CT (Set Current Transducer) Setup screen (see section A).
- Press **→** to go to the CT V screen. Use **+** or **-** to select the voltage mode Current Transducer output voltage (default is 0.33).
- Press **→** to go to the CT IZ screen and through the digits. Use **+** or **-** to select the CT size in amps (default is 100).
- Press **→** to accept the value and go back to the 5 CT screen.

### E. To Enter the service type to be monitored:

- Navigate to the 5 SYS (Set System) Setup screen (see section A).
- Press **→** to go to the SYSTP screen. Use **+** or **-** to select the configuration (see wiring diagrams - default is 3L-1N).
- Press **→** to go back to the 5 SYS screen.

Page 15

## China RoHS Compliance Information (EFUP Table)

Part Name	有害物质 - Hazardous Substances					
	铅 (Pb)	汞 (Hg)	镉 (Cd)	六价铬 (Cr (VI))	多溴联苯 (PBB)	多溴二苯醚 (PBDE)
电子件 Electronic	X	O	O	O	O	O

本表格依据SJ/T11364的规定编制。  
O: 表示该有害物质在该部件所有均质材料中的含量均在GB/T 26572规定的限量要求以下。  
X: 表示该有害物质至少在该部件的某一均质材料中的含量超出GB/T 26572规定的限量要求。  
(企业可在此处, 根据实际情况对上表中打 \* 的技术原因进行进一步说明。)

This table is made according to SJ/T 11364.  
O: indicates that the concentration of hazardous substance in all of the homogeneous materials for this part is below the limit as stipulated in GB/T 26572.  
X: indicates that concentration of hazardous substance in at least one of the homogeneous materials used for this part is above the limit as stipulated in GB/T 26572

Z000057-08

**Schneider Electric**  
35, rue Joseph Monier  
92500 Rueil Malmaison  
France  
+ 33 (0) 1 41 29 70 00  
www.se.com

**Schneider Electric Limited**  
Stafford Park 5  
Telford TF3 3BL  
United Kingdom

ION, Modbus, and PowerLogic are either trademarks or registered trademarks of Schneider Electric in France, the USA and other countries. Other trademarks used are the property of their respective owners. Electrical equipment should be installed, operated, serviced, and maintained only by qualified personnel. No responsibility is assumed by Schneider Electric for any consequences arising out of the use of this material.

©2021 Schneider Electric. All Rights Reserved.

Page 16