

**Customer Care Center**

Reach out to our Customer Care team in your location:

# Legal Information

The Schneider Electric brand and any trademarks of Schneider Electric SE and its subsidiaries referred to in this guide are the property of Schneider Electric SE or its subsidiaries. All other brands may be trademarks of their respective owners.

This guide and its content are protected under applicable copyright laws and furnished for informational use only. No part of this guide may be reproduced or transmitted in any form or by any means (electronic, mechanical, photocopying, recording, or otherwise), for any purpose, without the prior written permission of Schneider Electric.

Schneider Electric does not grant any right or license for commercial use of the guide or its content, except for a non-exclusive and personal license to consult it on an "as is" basis. Schneider Electric products and equipment should be installed, operated, serviced, and maintained only by qualified personnel.

As standards, specifications, and designs change from time to time, information contained in this guide may be subject to change without notice.

To the extent permitted by applicable law, no responsibility or liability is assumed by Schneider Electric and its subsidiaries for any errors or omissions in the informational content of this material or consequences arising out of or resulting from the use of the information contained herein.

---

# Contact Information

For country-specific details, please contact your local Schneider Electric Sales Representative or visit the Schneider Electric website at: <https://www.se.com/>

---

# Information About Your System

As soon as you open your product, inspect the contents and record the following information and be sure to keep your proof of purchase. If any damage is found, contact customer support.

|                               |                      |
|-------------------------------|----------------------|
| Serial Number _____           | Purchased From _____ |
| Product Number _____          | Purchase Date _____  |
| Document Number:TME91311023EN | Date: 2025-09-01     |

---

# Information on Non-Inclusive or Insensitive Terminology

As a responsible, inclusive company, Schneider Electric is constantly updating its communications and products that contain non-inclusive or insensitive terminology. However, despite these efforts, our content may still contain terms that are deemed inappropriate by some customers.

---

# Validity Note

This document is valid only for the Schneider Pro&EcoStruxure Energy Asset Controller commissioning.

If this manual is in any language other than English, although steps have been taken to maintain the accuracy of the translation, the accuracy of language expression will be biased. Approved content is contained with the English language version which is posted at <https://www.se.com/>.

The characteristics of the products described in this document are to match the characteristics that are available on <https://www.se.com/>. As a part of our corporate strategy for constant improvement, we may revise the content over time to enhance clarity and accuracy. If you see a difference between the characteristics in this document and the characteristics on <https://www.se.com/>, consider <https://www.se.com/> to contain the latest information.

---

# Document Description

## Product Series Manuals Include:





Please read the following manuals in sequence before installation and operation:

|  |   |
|--|---|
| <b>Battery Energy Storage System Integration Guide</b> | <p>Covers product structure, core specifications, safety guidelines, and basic operational logic.</p> <ul style="list-style-type: none"><li>■ Purpose: Provides essential technical background for installation and commissioning. Guides post-installation checks, power-on self-tests, communication setup, performance testing, and compliance validation before system operation</li><li>■ Goal: Help O&amp;M commissioners quickly familiarize themselves with the system and master the commissioning and launch method of battery energy storage system.</li></ul> |
|--|---|

# Safety Information

## Important Information

Read these instructions carefully and look at the equipment to become familiar with the device before trying to install, operate, service or maintain it. The following special messages may appear throughout this documentation or on the equipment to warn of potential hazards or to call attention to information that clarifies or simplifies a procedure.

|   |   |
|---|---|
|  | The addition of either symbol to a "Danger" or "Warning" safety label indicates that an electrical hazard exists which will result in personal injury if the instructions are not followed. |
|  | This is the safety alert symbol. It is used to alert you to potential personal injury hazards. Obey all safety messages that follow this symbol to avoid possible injury or death.          |
|  | Hot surface.  |
|  | Protective Earth (grounding) conductor terminal.  |
|  | Refer to the Installation or Operation instructions.  |

### **⚠ DANGER**

**DANGER** indicates a hazardous situation which, if not avoided, **will result in** death or serious injury.

### **⚠ WARNING**

**WARNING** indicates a hazardous situation which, if not avoided, could result in death or serious injury.

### **⚠ CAUTION**

**CAUTION** indicates a hazardous situation which, if not avoided, **could result in** minor or moderate injury.

### **NOTICE**

**NOTICE** is used to address practices not related to physical injury.

## Aware About

Electrical equipment should be installed, operated, serviced, and maintained only by qualified personnel. No responsibility is assumed by Schneider Electric for any consequences arising out of the use of this material.

A qualified person is one who has skills and knowledge related to the construction, installation, and operation of electrical equipment and has received safety training to recognize and avoid the hazards involved. For more information, see Audience.

## Audience

- Site engineer
- System commissioning personnel
- Operation and maintenance management personnel

# Scope

The purpose of this integrated application guide is to guide the operation and maintenance commissioning engineers to establish the communication control relationship between Schneider Boost Pro and EcoStruxure Energy Asset Controller on the Webpage, and conduct energy management of the system.

## 1. System Architecture

The system architecture of this typical application scenario is shown in the following figure. (At present, the operation capacity of 10 parallel machines is verified).

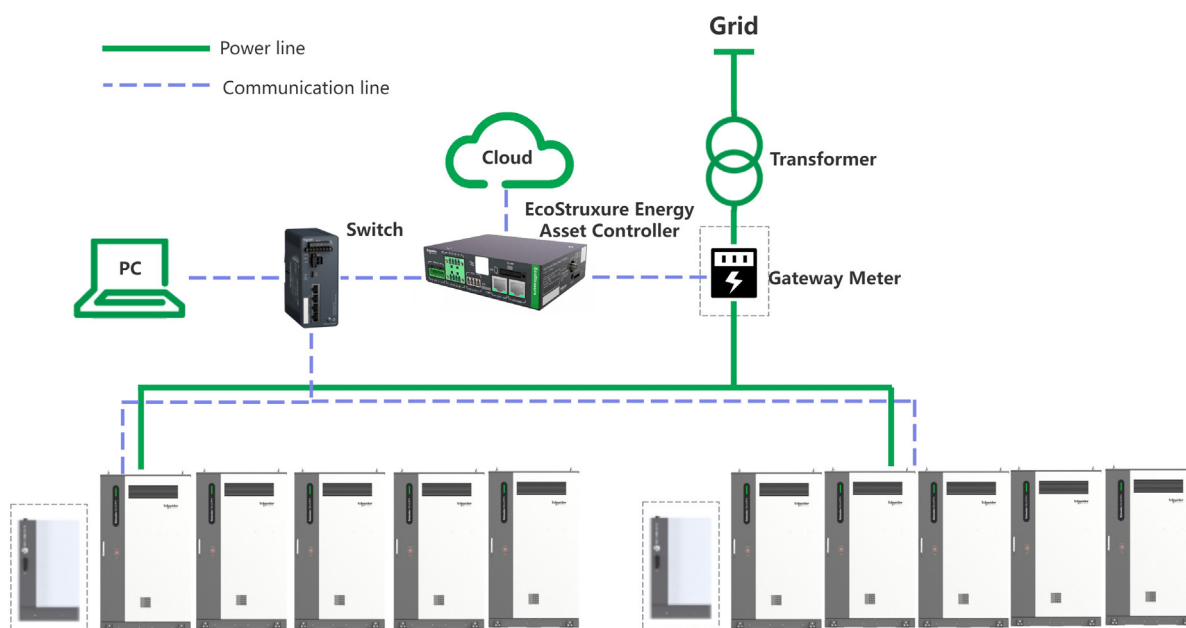

## 2. Components list

The above system architecture should include the following equipment, among which the meter, switch, eHub-500 are recommended models and optional.

| Product                             |           | CR                 | Functions   |
|-------------------------------------|-----------|--------------------|---|
| EcoStruxure Energy Asset Controller | Mandatory | EPCEACEU1          | EcoStruxure Energy Asset Controller.  |
| Schneider Boost Pro                 | Mandatory | BAT215KPCS100K3EU1 | Battery Energy Storage System.  |
| Network/Switch                      | Optional  | /                  | EcoStruxure Energy Asset Controller communication expander, which is an EcoStruxure Energy Asset Controller expansion network port and increases the number of Schneider Boost Pro access.                |
| eHub-500                            | Optional  | /                  | A device for electrical convergence, charge and discharge meter, power control of Schneider Boost Pro, and protection against reverse current fault of the whole system for up to 5 Schneider Boost Pros. |
| Power meter                         | Optional  | /                  | 1. It is used as a gateway meter to implement strategies such as anti-overcapacity and anti-backflow.<br>2. The statistical system runs data.   |

## 3. Documentation Reference

| Number | Manual Name   | Product Name   | Commercial Reference (CR)     |
|--------|---|--|-------------------------------|
| 1      | Schneider Boost Pro Installation and User Guide         | Schneider Boost Pro  | BAT215KPCS100K3EU1            |
| 2      | Schneider Boost Pro Maintenance Guide                   | Schneider Boost Pro  | BAT215KPCS100K3EU1            |
| 3      | EcoStruxure Energy Asset Controller User Guide          | EcoStruxure Energy Asset Controller                        | EPCEACEU1                     |
| 4      | EcoStruxure Energy Asset Controller Commissioning Guide | EcoStruxure Energy Asset Controller                        | EPCEACEU1                     |
| 5      | Battery Energy Storage System Integration Guide         | Schneider Boost Pro<br>EcoStruxure Energy Asset Controller | BAT215KPCS100K3EU1, EPCEACEU1 |

For more information about the Schneider Boost Pro, EcoStruxure Energy Asset Controller, related documents, specifications, and compatible equipment, see <https://www.se.com/>.

## Abbreviations and Acronyms

| Abbreviations and Acronyms |   |
|----------------------------|---|
| <b>AC</b>                  | Alternating Current                     |
| <b>DC</b>                  | Direct Current                          |
| <b>CAN</b>                 | Controller Area Network                 |
| <b>IP</b>                  | Internet Protocol of Ingress Protection |
| <b>SOC</b>                 | Stage of Charge                         |
| <b>BESS</b>                | Battery Energy Storage System           |
| <b>OTA</b>                 | Over-The-Air Technology                 |
| <b>MCCB</b>                | Molded Case Circuit Breaker             |
| <b>FW</b>                  | Firmware                                |

## Definitions of Terms

| Definitions of Terms                     |   |
|--|---|
| <b>EEAC</b>                              | EcoStruxure Energy Asset Controller   |
| <b>Webpage</b>                           | EcoStruxure Energy Asset Controller Webpage<br>The operating system completes the commissioning and online operation of Schneider Boost Pro and performs energy management with EcoStruxure Energy Asset Controller.  |
| <b>Schneider Boost Pro</b>               | Refer BESS  |
| <b>Anti-backflow</b>                     | When the system is connected to the grid, prevent Schneider Boost Pro from accessing the grid with reverse countercurrent power.  |
| <b>Anti-overcapacity</b>                 | Prevent the actual load capacity used in the system from exceeding the transformer or overall distribution capacity.  |
| <b>Peak cutting and valley filling</b>   | The Scheduling of Schneider Boost Pro instruction is issued through Webpage to control the charging and discharging of Schneider Boost Pro, so as to achieve the goal of peak clipping and valley filling.  |
| <b>Dynamic Capacity Expansion</b>        | EcoStruxure Energy Asset Controller monitors the system gateway meter data and controls Schneider Boost Pro to virtually increase transformer capacity.   |
| <b>Green electricity consumption</b>     | The green electricity consumption strategy will give priority to photovoltaic, which is not included in this typical application scenario system, so green power consumption is not applicable to this system.  |
| <b>Idle</b>                              | When Schneider Boost Pro state is idle, it means standby.   |
| <b>Power Meter</b>                       | Used for statistics on power, electricity consumption, and other information.<br>This system includes 2 meter, one is gateway meter, other is used to monitors the charge and discharge capacity of all Schneider Boost Pro in the whole system.<br>The gateway meter monitors the operation data of power grid and system, and cooperates with EcoStruxure Energy Asset Controller to complete the regulation and operation of the system. |
| <b>Scheduling of Schneider Boost Pro</b> | In Grid-connected system, which can control the operation of Schneider Boost Pro through Scheduling of Schneider Boost Pro in Webpage.  |
| <b>EMS Model</b>                         | Under the EMS mode,EcoStruxure Energy Asset Controller acts as the control hub of the system,managing Schneider Boost Pro,DC Fast Charging Station,PV Inverter based on predetermined control strategies  |
| <b>EUC Model</b>                         | Under the EUC mode,EcoStruxure Energy Asset Controller is a sub-device of 3rd-party EMS controller. As a unit controller,EcoStruxure Energy Asset Controller can only be connected to Schneider Boost Pro.  |

|   |           |
|---|-----------|
| <b>Legal Information</b> .....  | <b>2</b>  |
| <b>Contact Information</b> .....  | <b>2</b>  |
| <b>Information About Your System</b> .....                                      | <b>2</b>  |
| <b>Information on Non-Inclusive or Insensitive Terminology</b> .....            | <b>2</b>  |
| <b>Validity Note</b> .....  | <b>2</b>  |
| <b>Document Description</b> .....   | <b>2</b>  |
| <b>Safety Information</b> .....   | <b>3</b>  |
| <b>Aware About</b> .....  | <b>3</b>  |
| <b>Audience</b> .....   | <b>3</b>  |
| <b>Scope</b> .....  | <b>4</b>  |
| <b>Abbreviations and Acronyms</b> .....   | <b>5</b>  |
| <b>Definitions of Terms</b> .....   | <b>5</b>  |
| <b>1. Safety Information</b> .....  | <b>8</b>  |
| 1.1 General Information .....   | 8         |
| 1.2 Personnel Requirements .....  | 8         |
| 1.3 Electrical Requirements .....   | 9         |
| 1.4 Requirements for Environment .....  | 9         |
| <b>2. Typical Application Scenarios</b> .....                                   | <b>10</b> |
| 2.1 System Overview .....   | 10        |
| 2.2 System Architecture .....   | 10        |
| 2.3 Equipment Composition .....   | 10        |
| 2.4 Functions Introductions .....   | 11        |
| <b>3. Operation and Function Description of System</b> .....                    | <b>12</b> |
| 3.1 Data Uploading and Monitoring .....   | 14        |
| 3.2 Anti-overcapacity and Anti-backflow .....                                   | 14        |
| 3.3 Demand Control .....  | 15        |
| 3.4 Scheduling of Schneider Boost Pro .....                                     | 16        |
| 3.4.1 Idle .....  | 17        |
| 3.4.2 Charging .....  | 17        |
| 3.4.3 Discharging .....   | 18        |
| 3.4.4 Dynamic Capacity Expansion .....  | 18        |
| 3.4.5 Green Electricity Consumption .....                                       | 18        |
| 3.5 Connecting to 3rd Party EMS Controller .....                                | 19        |
| 3.6 FW Upgrade via OTA .....  | 20        |
| 3.6.1 EcoStruxure Energy Asset Controller FW OTA .....                          | 20        |
| 3.6.2 Schneider Boost Pro FW OTA .....  | 22        |
| <b>4. Preparation and Inspection Before System Commissioning</b> .....          | <b>24</b> |
| 4.1 Installation Confirmation .....   | 24        |
| 4.2 Communication Connection .....  | 25        |
| 4.2.1 Schneider Boost Pro .....   | 25        |
| 4.2.2 Power Meter .....   | 25        |
| 4.3 Power on the System .....   | 26        |
| 4.3.1 Pre-energization Checks .....   | 26        |
| 4.3.2 Power on the System .....   | 27        |
| 4.3.3 EcoStruxure Energy Asset Controller Power Supply .....                    | 30        |
| 4.3.4 Modification of Mode and IP after Schneider Boost Pro is Powered on ..... | 30        |

|  |           |
|--|-----------|
| <b>5. Commissioning with EcoStruxure Energy Asset Controller Webpage</b> .....                                 | <b>32</b> |
| 5.1 Connect EcoStruxure Energy Asset Controller to Computer .....  | 32        |
| 5.2 Log in System .....  | 32        |
| 5.3 System Settings Checking .....   | 32        |
| 5.4 Schneider Boost Pro & EcoStruxure Energy Asset Controller Integrated System Configuration in Webpage ..... | 32        |
| 5.4.1 Communication Topology .....   | 32        |
| 5.4.2 Control Topology .....   | 37        |
| <b>6. Power off the System</b> .....   | <b>40</b> |
| <b>7. Troubleshooting</b> .....  | <b>43</b> |

Before installing, commission, or operating the Schneider Boost and EcoStruxure Energy Asset Controller, read all instructions about Schneider Boost Pro and EcoStruxure Energy Asset Controller. For more detailed safety information, please refer to Documentation Reference 1~4.

## 1.1 General Information

### ⚠ DANGER

#### HAZARD OF ELECTRICAL SHOCK, EXPLOSION OR ARC FLASH

- Do not wear watches, bracelets, bangles, rings, necklaces and other easily conductive objects during installation, operation and maintenance to avoid being burned by electric shock.
- Special protective equipment must be used during installation, operation and maintenance; this should include insulated gloves, protective goggles, protective clothing, protective helmets and protective footwear.
- Installation, operation and maintenance must be carried out in accordance with the step-by-step sequence of the instructions.
- The voltage at the contact point should be measured before touching any conductor surface or terminal to confirm that there is no risk of electric shock.
- To be replaced by: Do not remove the protective devices.
- Live operation is not allowed during the installation process.
- Do not wash any electrical components located inside and outside the cabinet with water.
- Do not power on the equipment before completing the installation or having it confirmed by a professional.

**Failure to follow these instructions will result in death or serious injury.**

### ⚠ WARNING

#### RISK OF PERSONAL INJURY OR EQUIPMENT DAMAGE

- During the operation of the equipment, if any faults that may lead to personal injury or equipment damage are found, the operation must be stopped immediately, the project director informed, and effective protective measures taken.
- Before using any tools, please be aware of the correct way of using them.
- Before powering up the installation and after installing the equipment, any flammable materials such as cartons, foam, plastic and cable ties should be removed from the equipment area.
- In the event of a fire, evacuate the building or equipment area and press the fire alarm bell, or dial the fire reporting emergency number. Do not re-enter a burning building under any circumstances.
- Do not install, use and operate outdoor equipment and cables (including but not limited to carrying equipment, operating equipment and cables, plugging and unplugging signal interfaces connected to the outdoor area, working at heights, outdoor installation) under severe weather conditions such as thunder and lightning, rain, snow, or gusts of wind higher than grade six.
- Do not ignore warnings, cautions and notes described in manuals and on equipment.
- Replace hazard symbols that have become unclear due to long-term use immediately.
- Keep people other than those operating the equipment away from the equipment.
- All wiring holes need to be sealed, and fireproof putty should be used to seal the wiring holes.
- Do not artificially alter, damage or obscure the logo and nameplate on the equipment.
- When installing the equipment, use a torque wrench with the appropriate range and tighten the screws according to the torque value given in the instructions.
- Before operation, the equipment should be securely fixed to the floor or other stable object.
- Do not change the structure and installation sequence of the equipment without authorization.

**Failure to follow these instructions can result in death, serious injury, or equipment damage.**

### ⚠ CAUTION

#### HAZARD OF BURNS AND MECHANICAL INJURY

- Before the fan is powered off and stops running, do not touch the running fan with fingers, components, screws, tools, or veneer, in order to avoid injury to hands or damage to the equipment.
- Do not touch the equipment when it is in operation.

**Failure to follow these instructions can result in injury, burning or equipment damage.**

#### Statement:

- When installing, operating and maintaining the equipment, please read this manual first, and follow all labels on the equipment as well as all safety precautions described in the manual.
- The "Notice", "Caution", "Warning" and "Danger" items as highlighted in the manual do not represent all safety items needing to be observed, but are supplements to the overall safety precautions. The company shall not assume any responsibility caused by violation of general safety operation requirements or violation of safety standards in the design, production and use of the equipment.
- This equipment must be used in an environment that meets the design specifications. Otherwise it may cause equipment failure, resulting in functional abnormalities or component damage, personal safety accidents, property damage, etc., which are not within the scope of the equipment warranty.
- Local laws, regulations and codes should be observed when installing, operating and maintaining the equipment.
- The safety notices described in the manual are only a supplement to local laws, regulations and standards.

#### We are not liable for any of the following situations:

- The equipment has not been operated in line with the conditions of use described in this manual.
- The installation and/or operating environment exceeds the regulations described in the relevant international or national standards.
- The user disassembles or changes the product, or modifies the software without authorization.
- The user did not follow the operating instructions and safety warnings as described in the documentation.
- Damage to equipment caused by abnormal natural circumstances (force majeure: e.g. earthquake, fire, windstorm).
- Transport damage caused by customer transportation.
- Damage caused by storage conditions that do not meet the requirements of the product document.

## 1.2 Personnel Requirements

**▲ WARNING****RISK OF PERSONAL INJURY OR EQUIPMENT DAMAGE**

- The personnel responsible for the installation and maintenance of the equipment must first receive proper training to understand the required notices and to master the correct operating techniques.
  - Only qualified professionals or trained personnel are allowed to install, operate and maintain the equipment.
  - Only qualified professionals are allowed to remove notices and service the equipment.
  - All personnel who operate the equipment, including operators, trained personnel and professionals, should hold the requisite operating qualifications required by the local country, such as those engaged in HV operation, working at height, and other special equipment qualifications.
  - The equipment itself, as well as any of its parts (including software) can only be replaced by qualified or authorized personnel.
  - Personnel who have experience in training or operating the equipment, and are aware of potential sources and levels of danger in the process of equipment installation, operation, and maintenance.
  - Trained personnel: Personnel who have received the requisite technical training and have the necessary experience, are aware of the possible dangers when performing an operation, and can take measures to minimize danger to themselves and others.
  - Operators: All operators who may come into contact with the equipment, other than trained personnel and professionals.
- Failure to follow these instructions can result in death, serious injury, or equipment damage.**

## 1.3 Electrical Requirements

**▲ DANGER****HAZARD OF ELECTRICAL SHOCK, EXPLOSION OR ARC FLASH**

- Do not install or remove power cables while they live. The moment the power cable comes into contact with a conductor, an arc or spark can be produced, which may result in fire or personal injury.
- Incorrect operation may cause unexpected accidents such as fire or electric shock.
- Do not push the cable directly from the vehicle or perform other incorrect operations.
- Do not clean any electrical parts inside or outside the device using water, alcohol, oil, or similar liquids.
- The equipment should be permanently connected to the protective grounding conductor.
- Before operating the equipment, first check its electrical connections to ensure that it is reliably grounded.
- Before installing or removing the power cable, the power switch must be turned off.
- Before connecting the power cable, please ensure that the power cable label is correctly marked before the connection is made.
- Damaged parts must be replaced by a professional.
- If liquid enters the device, immediately turn off the power. Do not use the device any further.
- When installing equipment that requires grounding, the protective ground wire must be installed first; When removing the equipment, the protective ground wire must be removed last.
- Do not damage the grounding conductor.
- Do not operate the equipment without a grounding conductor installed.
- The equipment should be permanently connected to the protective grounding conductor.
- Before operating the equipment, first check its electrical connections to ensure that it is reliably grounded.
- Do not touch components with bare hands.
- Wear antistatic gloves before touching electron component or circuit board.

**Failure to follow these instructions will result in death or serious injury.**

**▲ WARNING****HAZARD OF FIRE OR EQUIPMENT DAMAGE**

- Flame-retardant cable with a flame-retardant grade complying with local laws and regulations should be used.
- Cables of the same type should be bundled together, while cables of different types should be laid separately, and must not be intertwined or crossed.
- Cables used in the energy storage system must be securely connected, properly insulated and sized.
- Ensure all connections are secure, properly insulated, and correctly sized.
- Cables must not pass through the air inlets and air outlets of the equipment.

**Failure to follow these instructions can result in death, serious injury, or equipment damage.**

## 1.4 Requirements for Environment

**▲ WARNING****HAZARD OF ELECTRIC SHOCK, EXPLOSION, ARC FLASH, AND FIRE**

- When the equipment is running, do not cover the vent or cooling system, as this may lead to a high temperature fire.
- The equipment should be installed in an area away from liquids, and should not be installed under any water pipes or air outlet containing condensed water; The equipment should not be installed underneath places prone to water leakage, such as A/C outlets, vents, and outlet windows in the equipment room, in order to prevent liquid from entering the equipment and causing equipment failure or short circuit.
- If liquid enters the equipment, turn off the power immediately and notify the site manager.
- Do not place the equipment in an environment containing flammable or explosive gases or smoke, and do not perform any operation in such an environment.
- Energy storage system installed in environments with a high salt content will become corroded and may cause fire. Do not install the energy storage system outdoors in a salty environment. A salty environment refers to any area within 2km of the coast or affected by onshore winds. Areas affected by onshore wind will vary depending on the particular weather conditions (such as typhoon, monsoon) or terrain (dikes, hills).
- Do not install the equipment in a high-humidity environment. (Requirements for humidity: 5-95%, no condensation).

**Failure to follow these instructions can result in death, serious injury, or equipment damage.**

# 2

## Typical Application Scenarios

This chapter primarily introduces the typical application scenarios covered in this manual, including system overview, system architecture, equipment composition, communication architecture and main system functions. The purpose of this chapter is primarily to enable users to gain a preliminary understanding of the system.

### 2.1 System Overview

This system, based on EcoStruxure Energy Asset Controller and a local Webpage system, implements intelligent management and control for Schneider Boost Pro. It can switch to an additional system controller. The system integrates multi-dimensional operation strategies, including: anti-overcapacity and anti-backflow protection, dynamic capacity increase adjustment, green power priority scheduling, dynamic demand control and other functional strategies, to build a flexible and efficient energy management system.

### 2.2 System Architecture

The system architecture is shown in the following figure (this guide manual is based on the parallel operation of 10 Schneider Boost Pro).

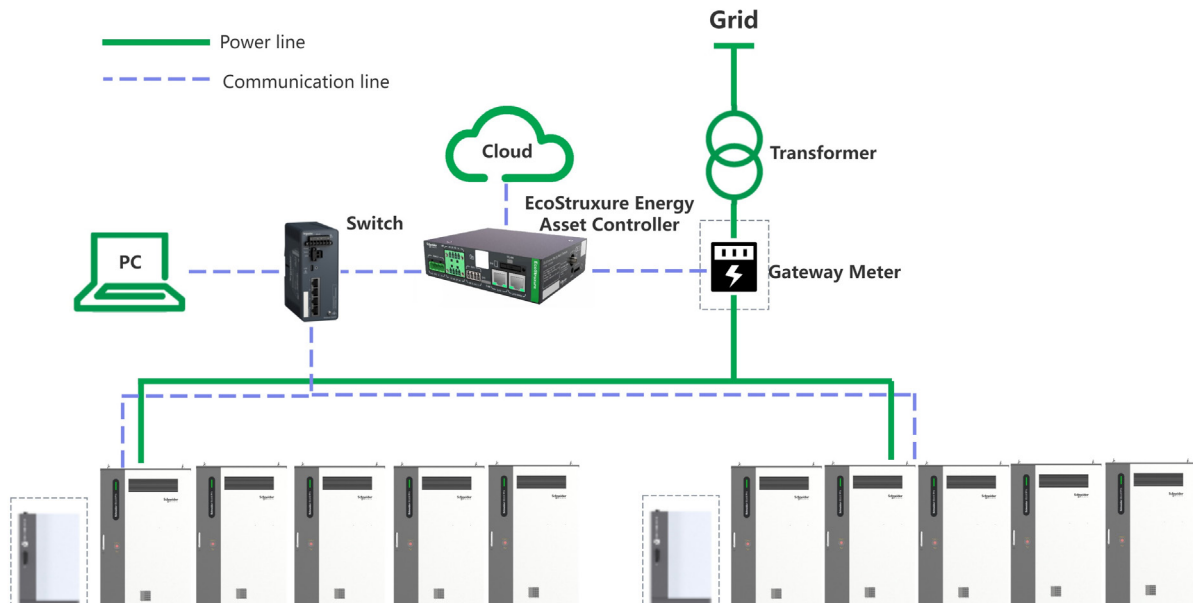

#### Examples of electrical wiring instructions for grid-connected mode system:

- The Schneider Boost Pro grid-connected cabinet eHub 500 in the system contains five 250A /3P plastic shell switches, which can support up to five Schneider Boost Pro connected in parallel.
- System grid connection mode: The upper end of the main circuit breaker of eHub500 cabinet is connected to the distribution cabinet on the mains side to realize grid connection.

#### Communication logic:

An EcoStruxure Energy Asset Controller manages one ESS meter, one gateway meter, 10 Schneider Boost Pro.

- RS485 communication mode is adopted between the gateway meter, ESS meter and EcoStruxure Energy Asset Controller.
- TCP communication mode is adopted between Schneider Boost Pro and EcoStruxure Energy Asset Controller.
- When there are a large number of Schneider Boost Pro, switches need to be configured to expand EcoStruxure Energy Asset Controller ports.

### 2.3 Equipment Composition

The above system architecture should include the following equipment, among which the meter, switch, eHub-500 are recommended models and optional.

| Product                             |           | CR                 | Functions   |
|-------------------------------------|-----------|--------------------|---|
| EcoStruxure Energy Asset Controller | Mandatory | EPCEACEU1          | EcoStruxure Energy Asset Controller   |
| Schneider Boost Pro                 | Mandatory | BAT215KPCS100K3EU1 | Battery Energy Storage System.  |
| Network/Switch                      | Optional  | /                  | EcoStruxure Energy Asset Controller communication expander, which is an EcoStruxure Energy Asset Controller expansion network port and increases the number of Schneider Boost Pro access.                |
| eHub-500                            | Optional  | /                  | A device for electrical convergence, charge and discharge meter, power control of Schneider Boost Pro, and protection against reverse current fault of the whole system for up to 5 Schneider Boost Pros. |
| Power meter                         | Optional  | /                  | 1. It is used as a gateway meter to implement strategies such as anti-overcapacity and anti-backflow.<br>2. The statistical system runs data.   |

## 2.4 Functions Introductions

| Function                             | Description  |
|--------------------------------------|--|
| Data uploading and monitoring        | If the device is successfully commissioning and online in Webpage, users can monitor the running status of each component in Webpage. This system can monitor the running state of Schneider Boost Pro and electric meter.   |
| Anti-backflow                        | The core control strategy of EcoStruxure Energy Asset Controller, through which the whole system is guaranteed not to exceed the capacity or reverse flow.   |
| Anti-overcapacity                    |  |
| Demand control                       | Demand control is a kind of EcoStruxure Energy Asset Controller control strategy, which controls the charging power of Schneider Boost Pro so that it does not affect the customers electricity demand. There are three main ways.   |
| Scheduling setting                   | In the grid-connected scenario, users can control the operation of Schneider Boost Pro through "Scheduling setting" in Webpage. It mainly includes five user-oriented scheduling modes: "idle", "charging", "discharging", "dynamic capacity expansion" and "green power consumption". |
| Connect the 3rd party EMS controller | EcoStruxure Energy Asset Controller provides EUC mode, which users can use to connect Schneider Boost Pro with an external third-party EMS controller.   |
| FW upgrade via OTA                   | Users can remotely upgrade the software of EcoStruxure Energy Asset Controller and Schneider Boost Pro through Webpage.  |

# 3 Operation and Function Description of System

The system functions introduced in this chapter need to be viewed and operated through Webpage. Therefore, before introducing the function details, first introduce how to log in to Webpage for users, so that they can quickly get familiar with the system during subsequent commissioning.

## NOTICE

### RISK OF ACCOUNT LOCKOUT OF RESTRICTED ACCESS TO ONLINE SERVICES

- When logging in to the Webpage, you need to prepare a network cable to connect the computer and EcoStruxure Energy Asset Controller, otherwise you cannot log in to the system.
- The computer used should be equipped with a network port to connect the network cable. If the computer does not have a network port, please prepare a network port converter and a network cable in advance.
- Ensure correct password entry, including case-sensitive, no types or extra spaces.
- Pause and verify credentials if unsure; avoid rapid consecutive attempts.
- Store passwords securely to prevent accidental errors.
- Only 3 attempts are allowed. Exceeding 3 attempts will lock the webpage for 3600 seconds
- The reset password must be 8 to 31 characters long and must include uppercase letters, lowercase letters, numbers, and special characters (-!:\$@.,?).
- Failure to follow these instructions can result in system malfunction.

**Failure to follow these instructions can result in system malfunction.**

First, connect EcoStruxure Energy Asset Controller to computer.



- Prepare a computer equipped with an Ethernet port (if not available, provide a USB-to-Ethernet adapter) and a standard Ethernet cable;
- Connect one end of the Ethernet cable to the computer's Ethernet port and the other end to any available port on the switch connected to the EcoStruxure Energy Asset Controller.

After the computer is connected to EcoStruxure Energy Asset Controller, you can enter 192.168.1.136 in the browser to enter the system login page, and complete the system commissioning and online according to the following configuration process.



Next, log in Webpage.

**Step 1:** Open the computer browser, enter "192.168.1.136" in the address bar, enter the following page, enter the user name and login password.

Initial user name: Admin

Initial password: 1234

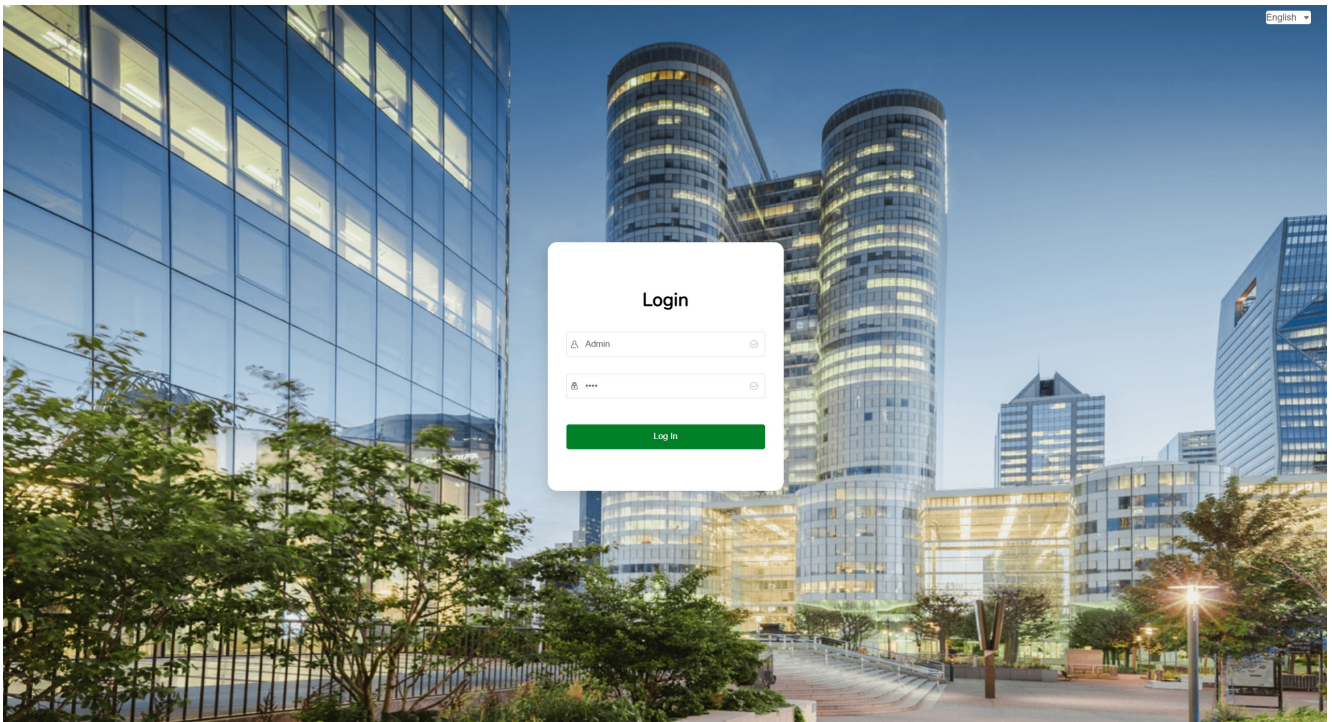

# 3

## Operation and Function Description of System

**Step 2:** Change the password.



**Step 3:** The system commissioning and online operation of this manual are based on Webpage. Choose "Not Connect to Schneider OMC Cloud". Click next and wait for the device to restart and log in to the Webpage again.

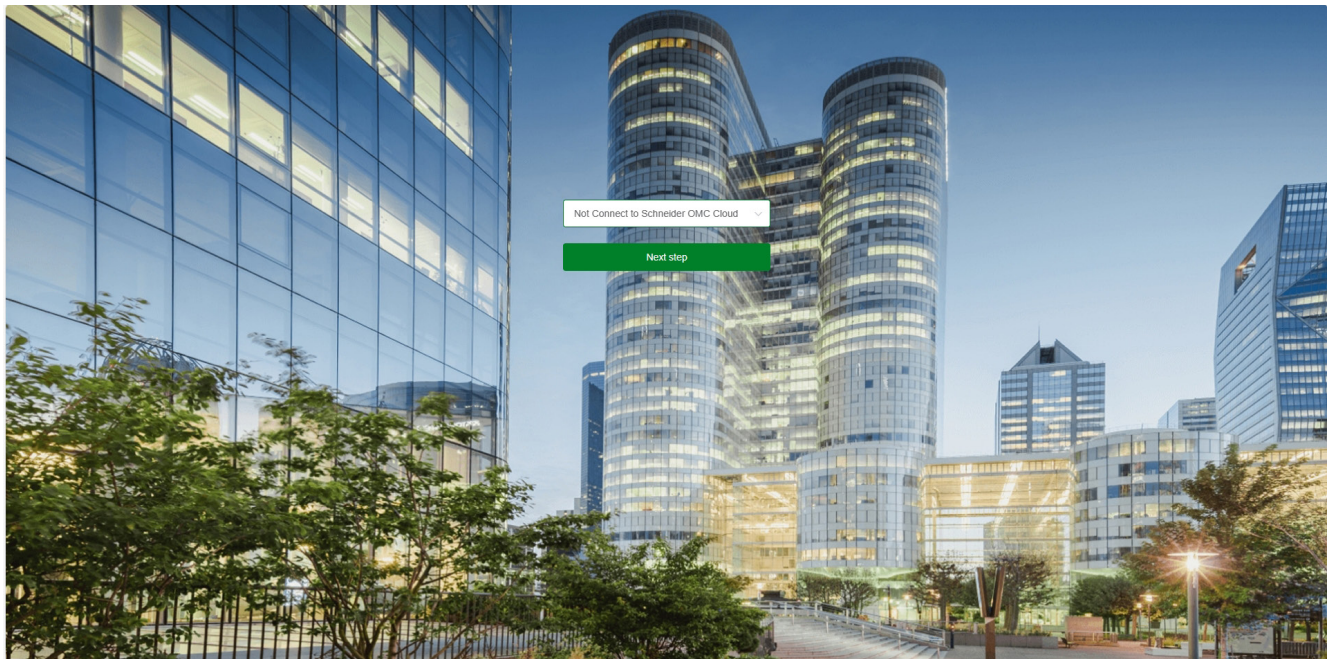

# 3 Operation and Function Description of System

## 3.1 Data Uploading and Monitoring

- Entering the Webpage, you can see three menu bars on the left, and users can view the real-time running data of the equipment through "running status".
- When you first enter Webpage, the menu bar here will be empty because no devices such as Schneider Boost Pro have been created in Webpage.
- After commissioning the equipment in Webpage with reference to Chapter 5, you can check the running status of the equipment.

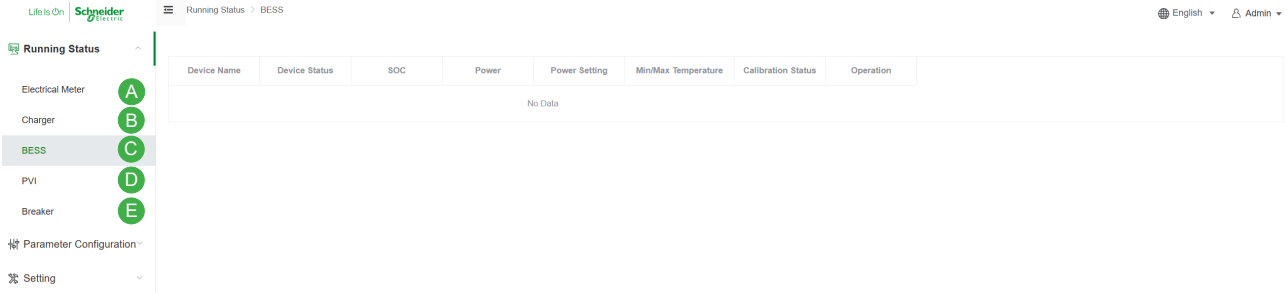

| # | Menu             | Functions   |
|---|------------------|---|
| A | Electrical Meter | View real-time data of electricity meters in the system.              |
| B | Charger          | View the operational data of DC charging piles and AC charging piles. |
| C | BESS             | View the operational data of Schneider Boost Pro.                     |
| D | PVI              | View the operational data of PV.                                      |
| E | Breaker          | View the operational data of Electrically operated switch.            |

Note: According to the typical application framework described in Chapter 2, after device creation, only status viewing for A and C is included.

## 3.2 Anti-overcapacity and Anti-backflow

### NOTICE

#### RISK OF OVERCAPACITY AND REVERSE POWER FLOW

- Although EcoStruxure Energy Asset Controller will give default parameters, the actual operating parameters need to be adjusted according to the station conditions, which will help maximize the use of the energy storage system under the premise of preventing overcapacity and backflow.
- Failure to follow these instructions can result in system malfunctions and even legal consequences.**

Anti-overcapacity and anti-backflow is a kind of EcoStruxure Energy Asset Controller control strategy, which is related to the overcapacity and backflow of the whole station. Anti-overcapacity and Anti-backflow control parameters are distributed through "Control Topology" in Chapter 5. See Chapter 5 for detailed distribution steps. Policy logic is introduced here.

- The anti-overcapacity control strategy can maximize the efficiency of power distribution capacity and reduce the risk of overcapacity.
- If the station is equipped with photovoltaic or Schneider Boost Pro, and grid-connected power generation is not allowed, anti-black flow and anti-overcapacity control is required.

In this manual, the rated capacity of the gateway meter is 150kVA, and the default value of the control parameters of the excess capacity counter current is taken as an example to explain the control mode. The following table demonstrates the specific control logic. Please note that the above parameters support to be modified and set according to the situation of the field system in practical application.

| Policy pattern    | Explain  |
|-------------------|--|
| Anti-overcapacity | <ul style="list-style-type: none"> <li>■ The upper limit of the super capacity control coefficient is <math>150 * (1-2\%) = 150 * 98\% = 147\text{kW}</math></li> <li>■ The lower limit of the super capacity control coefficient is <math>150 * (1-5\%) = 150 * 95\% = 142.5\text{kW}</math></li> <li>■ Therefore, when the station is about to exceed the capacity, EcoStruxure Energy Asset Controller will keep the off-grid power in this range as much as possible. Ensure that the system does not exceed capacity.</li> </ul> <p>                     P: power from grid<br/>                     Pmax: capacity or demand limit<br/>                     ▲H: up limit of power control<br/>                     ▲L: low limit of power control                 </p> |

### 3.2 Anti-overcapacity and Anti-backflow

| Policy pattern | Explain  |
|----------------|--|
| Anti-backflow  | <ul style="list-style-type: none"> <li>■ Upper limit of reverse flow control coefficient = <math>150 \times 5\% = 7.5\text{kW}</math></li> <li>■ The lower limit of the reverse flow control coefficient is <math>150 \times 3\% = 4.5\text{kW}</math></li> <li>■ The EcoStruxure Energy Asset Controller representative will control the off-grid power to be maintained between 4.5 and 7.5kW</li> </ul> |

### 3.3 Demand Control

Demand control is a kind of EcoStruxure Energy Asset Controller control strategy, which controls the power of Schneider Boost Pro so that it does not affect the customers electricity demand. There are three main ways.

Demand control parameters are distributed through "Control Topology" in Chapter 5. See Chapter 5 for detailed distribution steps. Policy logic is introduced here.

| Parameter name                 | Description  |
|--------------------------------|--|
| Capacity Control               | The power of controllable devices is controlled by the rated capacity given by the superior transformer or superior power supply unit.   |
| Static Demand Control          | <p>Control the power of controllable devices within the set time period according to the monthly initial demand set by the user. For specific demand settings, please refer to &lt;Communication topology&gt;.</p>   |
| Dynamic Demand Control         | <p>First, control the monthly initial demand according to the user's setting. If the monthly initial demand is exceeded due to the excessive load power not controlled by EcoStruxure Energy Asset Controller, record it and raise the subsequent demand control line to make full use of the available power. For specific demand settings, please refer to &lt;Communication topology&gt;.</p> |
| Power Priority at Overcapacity | When overcapacity occurs, the user can choose to reduce the BESS charging power or the power of other loads first according to the actual situation.   |

# 3 Operation and Function Description of System

## 3.4 Scheduling of Schneider Boost Pro

Before introducing the five modes, first instruct users how to use the "Scheduling of Schneider Boost Pro" function.

- Click "Parameter Configuration" → "Schedule Setting" to enter the schedule distribution page. You can see the following information in the page.

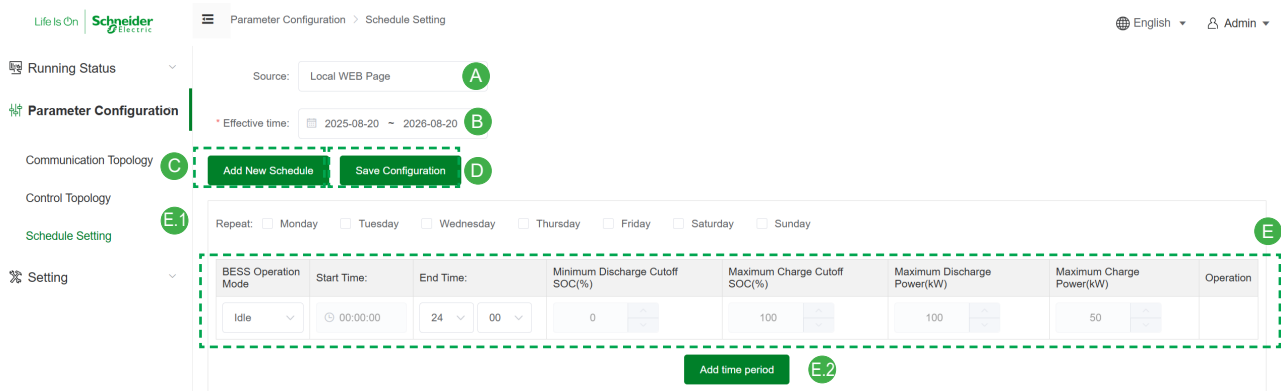

Parameter descriptions are as follows:

| #   | Parameter Name               | Functions  |
|-----|------------------------------|--|
| A   | Source                       | Select the scheduled distribution method. The current system is commissioning and running in Webpage, so choose "local WEB Page". If you need to use OMC to distribute the schedule in the future, you need to change the source to "JV OMC" here. |
| B   | Effective time               | Set the effective period of the schedule.  |
| C   | Add New Schedule             | Add a new schedule within the effective time. Multiple schedules cannot be Repeat before. Add New Schedule is generally used to run different schedules within an effective time.  |
| D   | Save Configuration           | Save the schedule and distribute it, and Schneider Boost Pro runs according to the schedule.   |
| E   | Scheduling mode setting area | Schedule setting area.   |
| E.1 | Repeat                       | Select the dates within a week that need to be repeated. If not all dates are selected, you can add a new schedule to complete them.   |
| E.2 | Add time period              | Add scheduled time period  |

- How to distribute the schedule is as follows.

**A:** Choose source and set Effective time.

**B:** In Scheduling mode setting area, set parameters such as "BESS operation mode" and choose Repeat.

Note: A complete scheduling cycle must include Monday to Sunday.

**C:** Click "Save Configuration", the Schneider Boost Pro will start to execute the set charge and discharge schedule within the effective period.

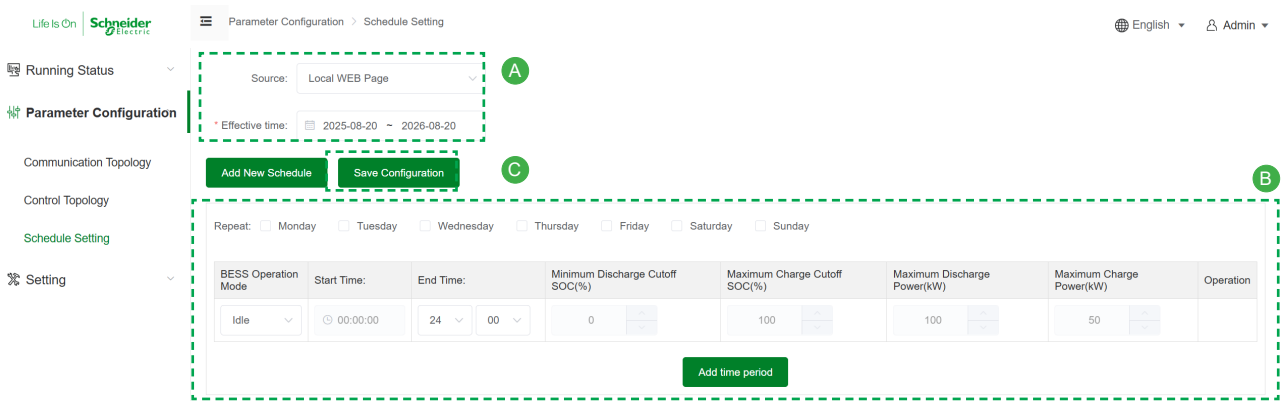

# 3 Operation and Function Description of System

## 3.4 Scheduling of Schneider Boost Pro

- In the step 2 troubleshooting settings area, there are the following parameters that need to be configured manually. Here we provide an introduction to each parameter.

| Scheduling                       | Description   |
|----------------------------------|---|
| BESS Operation Mode              | Select the operating mode of Schneider Boost Pro, including "Idle", "Charge", "Discharge", "Dynamic Capacity Expansion", and "Green Power Consumption".<br>Note: Detailed descriptions of the five modes are shown in sections 3.4.1 to 3.4.5 below.  |
| Start Time                       | When selecting an operating mode, the corresponding effective start time.   |
| End Time                         | When selecting an operating mode, the corresponding effective end time.   |
| Minimum Discharge Cutoff Soc (%) | When setting the "Discharge", "Dynamic Capacity Expansion", and "Green Power Consumption" operation modes, it indicates that Schneider Boost Pro will stop discharging upon reaching the specified discharge cutoff SOC.<br>Note: If any Schneider Boost Pro in the system reaches this set value, that Schneider Boost Pro will stop discharging.  |
| Maximum Charge Cutoff Soc (%)    | When setting the "Charge," "Dynamic Capacity Expansion," and "Green Power Consumption" operating modes, it indicates that Schneider Boost Pro will stop charging upon reaching the specified charge termination SOC.<br>Note: If any Schneider Boost Pro in the system reaches this set value, that Schneider Boost Pro will stop charging.   |
| Maximum Discharge Power (kW)     | When setting the "Discharge", "Dynamic Capacity Expansion", and "Green Power Consumption" operation modes, it indicates that Schneider Boost Pros' maximum discharge power.<br>Note: If the system contains multiple Schneider Boost Pro units, the maximum discharge power set here represents the combined discharge power of all Schneider Boost Pro units, with power being equally distributed among multiple Schneider Boost Pro units. |
| Maximum Charge Power (kW)        | When setting the "Charge", "Dynamic Capacity Expansion", and "Green Power Consumption" operation modes, it indicates that Schneider Boost Pros' maximum charge power.<br>Note: If the system contains multiple Schneider Boost Pro units, the maximum charge power set here represents the combined discharge power of all Schneider Boost Pro units, with power being equally distributed among multiple Schneider Boost Pro units.          |
| Operation                        | Operation bar, delete scheduling  |

### 3.4.1 Idle

- "Idle" is a kind of Schneider Boost Pro scheduling, when setting "Idle", Schneider Boost Pro is standby, no charging or discharging.
- The schedule settings are as follows. Grayed-out items cannot be modified.

### 3.4.2 Charging

- "Charging" is a kind of Schneider Boost Pro scheduling, when setting "Charging", Schneider Boost Pro will charging in order.
- The schedule settings are as follows. Grayed-out items cannot be modified.

# 3 Operation and Function Description of System

## 3.4 Scheduling of Schneider Boost Pro

### 3.4.3 Discharging

- "Discharging" is a kind of Schneider Boost Pro scheduling, When setting "Charging", Schneider Boost Pro will discharging in order.
- The schedule settings are as follows. Grayed-out items cannot be modified.

Parameter Configuration > Schedule Setting

Source: Local WEB Page

\* Effective time: 2025-08-20 - 2026-08-20

Repeat:  Monday  Tuesday  Wednesday  Thursday  Friday  Saturday  Sunday

| BESS Operation Mode | Start Time: | End Time: | Minimum Discharge Cutoff SOC(%) | Maximum Charge Cutoff SOC(%) | Maximum Discharge Power(kW) | Maximum Charge Power(kW) | Operation |
|---------------------|-------------|-----------|---------------------------------|------------------------------|-----------------------------|--------------------------|-----------|
| Dischar             | 00:00:00    | 18:00     | 0                               | 100                          | 100                         | 50                       |           |

Add time period

### 3.4.4 Dynamic Capacity Expansion

- Dynamic capacity expansion is a kind of Schneider Boost Pro scheduling, which aims to solve the problem of insufficient transformer capacity. The specific operation process is as follows:
  - When the transformer capacity is greater than the load power, Schneider Boost Pro charges.
  - When the transformer capacity is less than the load power, Schneider Boost Pro discharges.
- The schedule settings are as follows, Grayed-out items cannot be modified.

Parameter Configuration > Schedule Setting

Source: Local WEB Page

\* Effective time: 2025-08-20 - 2026-08-20

Repeat:  Monday  Tuesday  Wednesday  Thursday  Friday  Saturday  Sunday

| BESS Operation Mode | Start Time: | End Time: | Minimum Discharge Cutoff SOC(%) | Maximum Charge Cutoff SOC(%) | Maximum Discharge Power(kW) | Maximum Charge Power(kW) | Operation |
|---------------------|-------------|-----------|---------------------------------|------------------------------|-----------------------------|--------------------------|-----------|
| Dynamical           | 00:00:00    | 18:00     | 0                               | 100                          | 100                         | 50                       |           |

Add time period

### 3.4.5 Green Power Consumption

- Green Power consumption is a kind of Schneider Boost Pro scheduling, aiming to maximize the use of solar energy and reduce light waste. Its main operation process is as follows:
  - When the photovoltaic power is greater than the load power, the excess power is stored for charging.
  - When the photovoltaic power is less than the load power, the insufficient power is made up for Schneider Boost Pro discharging.
- The schedule settings are as follows, Grayed-out items cannot be modified.

Parameter Configuration > Schedule Setting

Source: Local WEB Page

\* Effective time: 2025-08-20 - 2026-08-20

Repeat:  Monday  Tuesday  Wednesday  Thursday  Friday  Saturday  Sunday

| BESS Operation Mode | Start Time: | End Time: | Minimum Discharge Cutoff SOC(%) | Maximum Charge Cutoff SOC(%) | Maximum Discharge Power(kW) | Maximum Charge Power(kW) | Operation |
|---------------------|-------------|-----------|---------------------------------|------------------------------|-----------------------------|--------------------------|-----------|
| Green F             | 00:00:00    | 18:00     | 0                               | 100                          | 100                         | 50                       |           |

Add time period

# 3 Operation and Function Description of System

## 3.5 Connecting to 3rd Party EMS Controller

The EUC mode means Energy Unit Controller mode, provided by EcoStruxure Energy Asset Controller, is used for the direct control of third-party controller devices. To enable direct control, the EcoStruxure Energy Asset Controller must be set to EUC mode. When the EcoStruxure Energy Asset Controller is in EUC mode, it only handles the transmission and reception of commands and data, not the power control of the site. The upper-level EMS controller is the control core of the system, such as reducing over-consumption and reverse flow. The specific settings are as follows:

If you need to use the EUC mode, you need to configure the communication topology between the EUC and the device in the local WEB to ensure normal communication of the device.

### NOTICE

#### RISK OF COMMUNICATION FAILURE

- When EcoStruxure Energy Asset Controller is switched to EUC mode, only the communication topology needs to be configured to make device communication, and no control topology needs to be configured.
- When EcoStruxure Energy Asset Controller is in EUC mode, only Schneider Boost Pro can be connected, and other devices in the system do not support connection.

**Fail to follow the instructions may result in system malfunction.**

**Step 1:** Click "Parameter Configuration" → "communication topology", users can see that the current EcoStruxure Energy Asset Controller is "EMS mode", click on the EUC mode to modify the EcoStruxure Energy Asset Controller into EUC mode.

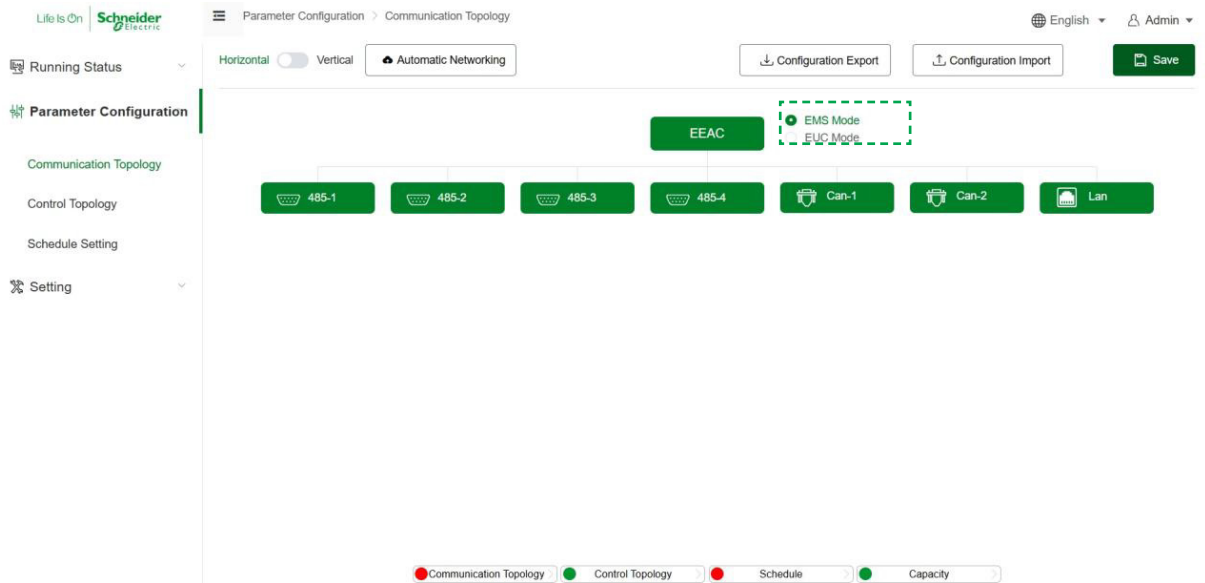

**Step 2:** Click "Save" after modification, the "reset" pop-up box pops up, and click "confirm", and wait for the EcoStruxure Energy Asset Controller to restart. After restart, the EUC mode is successfully modified.

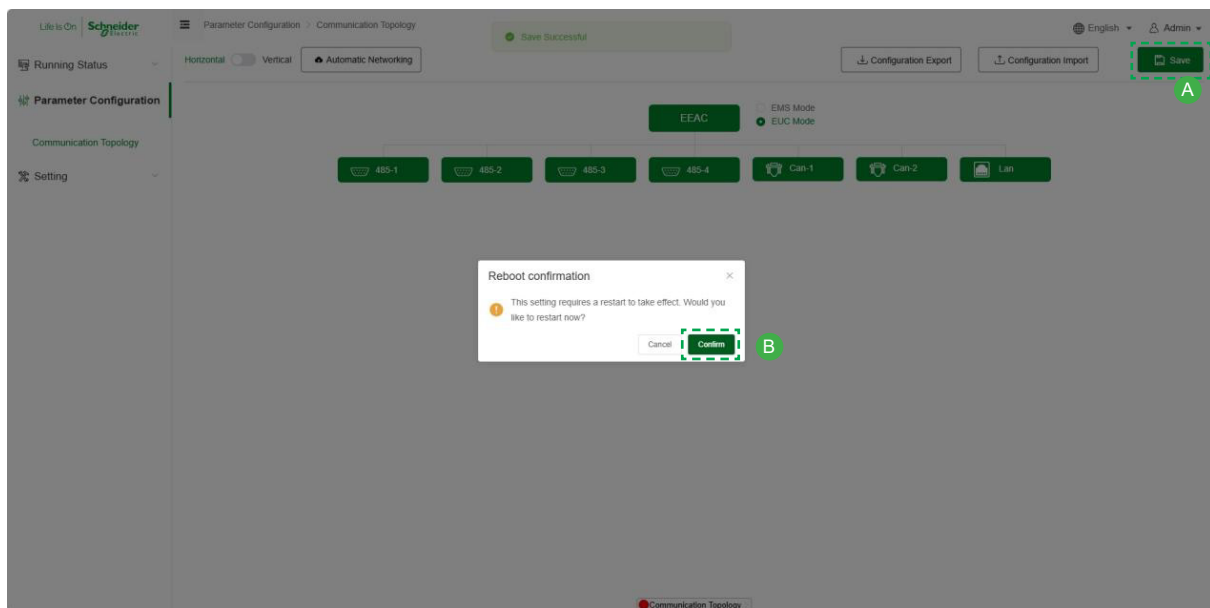

# 3 Operation and Function Description of System

## 3.5 Connecting to 3rd Party EMS Controller

It can be seen that the current device has been switched to EUC mode and is ready for communication with Schneider Boost Pro. When Schneider Boost Pro communicates with EUC, the system has the following functions:

- Receiving third-party EMS control instructions to control Schneider Boost Pro's charging and discharging.
- Uploading data from Schneider Boost Pro to a third-party EMS via EUC.

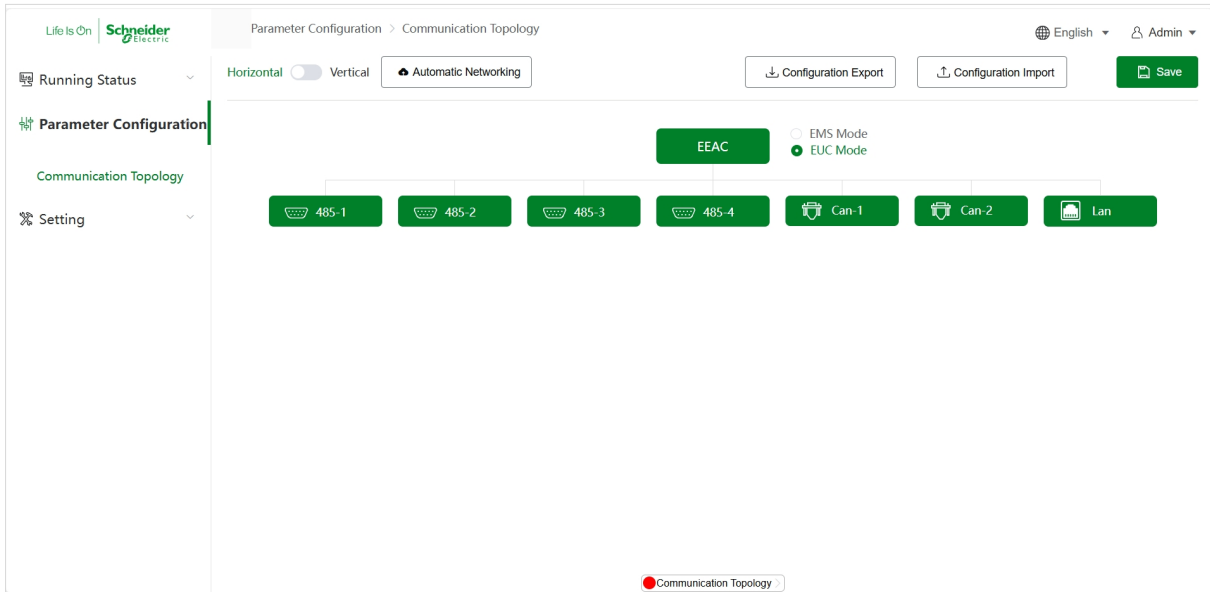

## 3.6 FW Upgrade via OTA

In Webpage, users can remotely upgrade the firmware of EcoStruxure Energy Asset Controller and Schneider Boost Pros.

### 3.6.1 EcoStruxure Energy Asset Controller FW OTA

- Check FW version: Clicking "setting" → "system", users can see current EcoStruxure Energy Asset Controller firmware version in "EEAC Firmware". As shown in the figure, EcoStruxure Energy Asset Controller is V3.6.0 -JV.

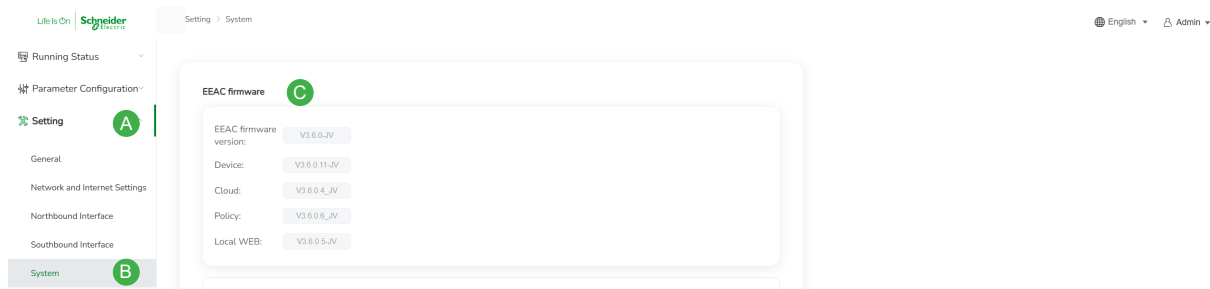

- FW OTA: If you want to upgrade the firmware of EcoStruxure Energy Asset Controller, you can OTA in below area.

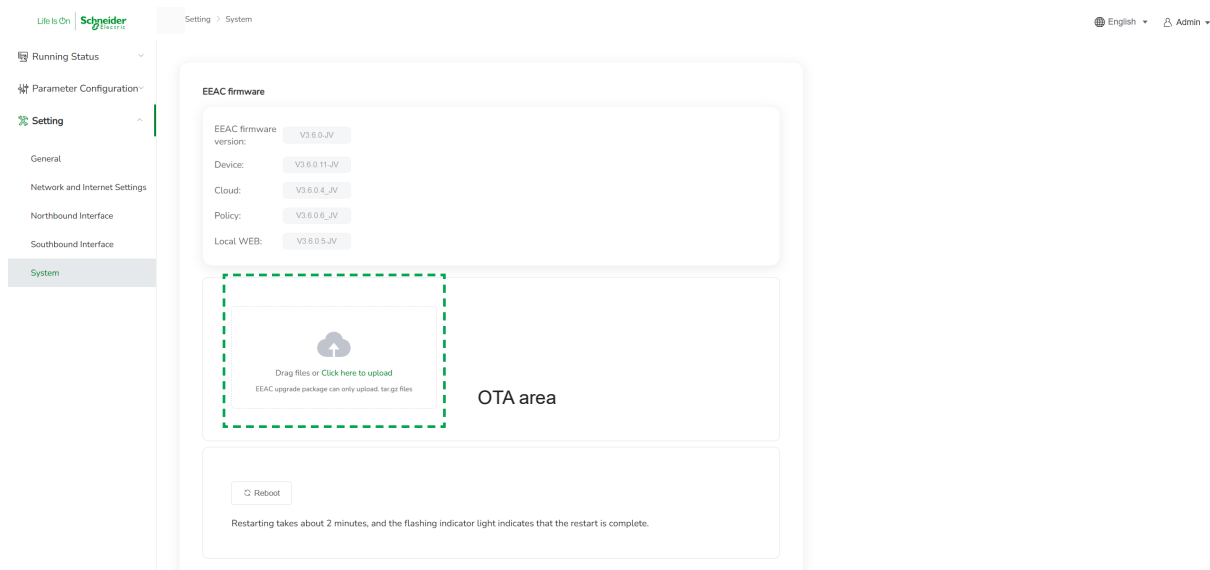

# 3 Operation and Function Description of System

## 3.6 FW Upgrade via OTA

OTA steps are as follows:

**Step 1:** Drag the upgrade package to this area and wait for the progress bar to reach 100%. At this time, EcoStruxure Energy Asset Controller is running normally.  
Light effect: Red light flashes twice.

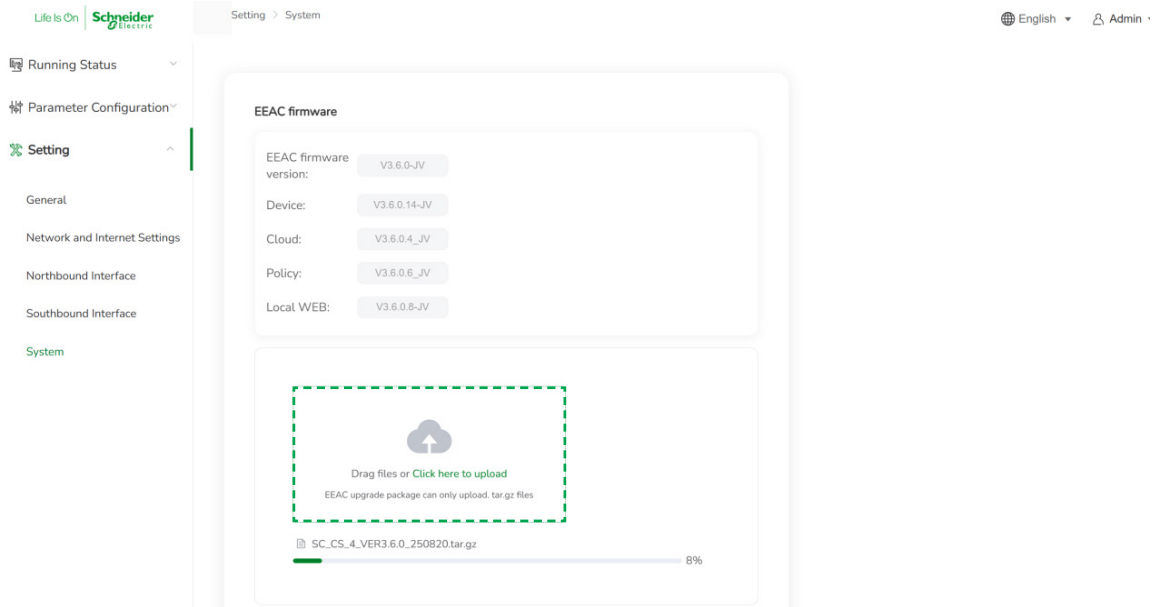

**Step 2:** After the upgrade package progress bar is transmitted, the upgrading progress bar will pop up and wait for the upgrading progress bar to reach 100%. At this time, EcoStruxure Energy Asset Controller is in normal operation state. Light effect: Double flash of red light.

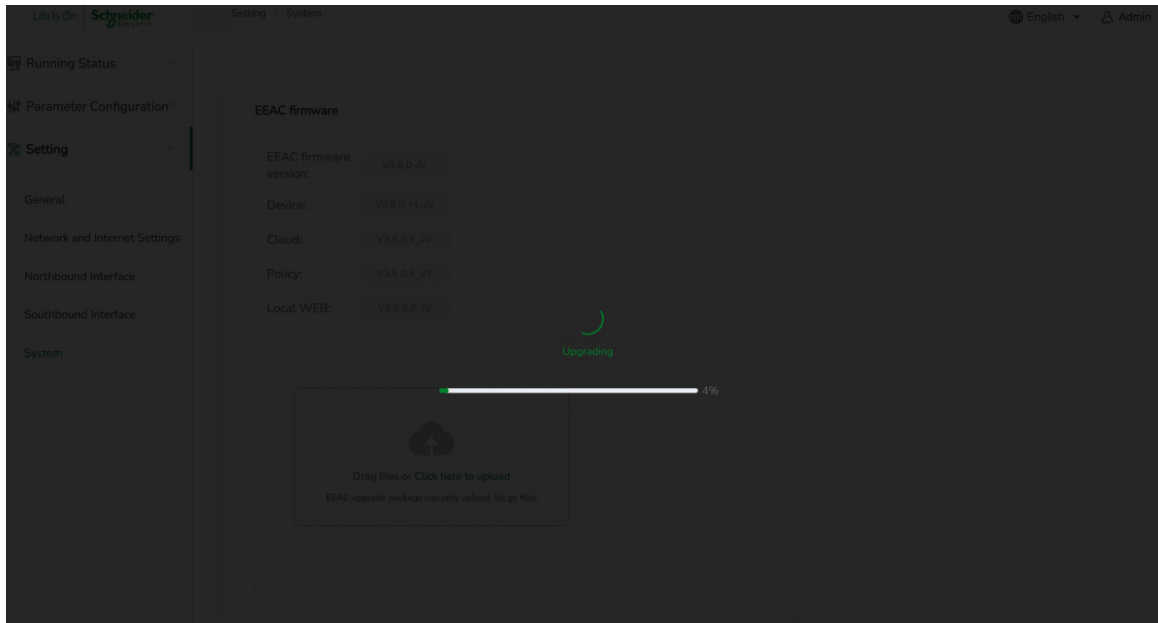

# 3 Operation and Function Description of System

## 3.6 FW Upgrade via OTA

**Step 3:** After the upgrade progress bar is transmitted, a confirmation box for restarting EcoStruxure Energy Asset Controller will pop up. Click OK to restart EcoStruxure Energy Asset Controller. Light effect: The red light will change from flashing to off.

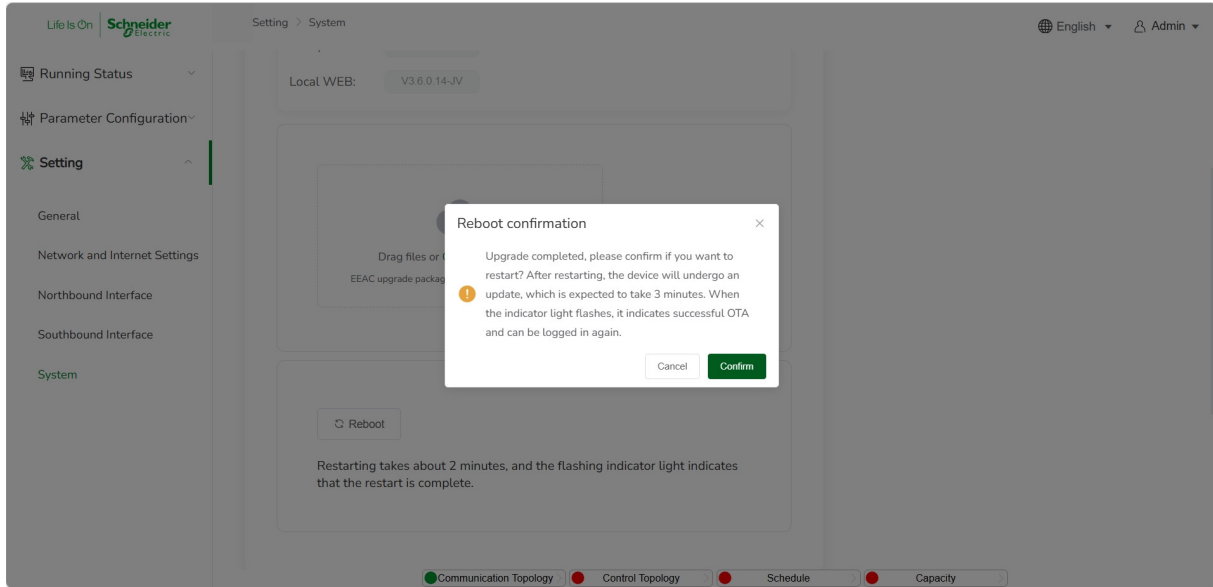

**Step 4:** After clicking OK, EcoStruxure Energy Asset Controller restarts. After the red flashing light is extinguished, the red light stays on. Wait for it to become red flashing again, and you can log in to the system again. The EcoStruxure Energy Asset Controller firmware upgrade is successful.

Note: When restarting, EcoStruxure Energy Asset Controller will disconnect the communication with Schneider Boost Pro, and the Boost Pro light effect is in a red light state, accompanied by a buzzer, waiting for about 2 minutes after the successful restart of EcoStruxure Energy Asset Controller to resume communication with Schneider Boost Pro.

### 3.6.2 Schneider Boost Pro FW OTA

- Check FW version: At present, the software version of Schneider Boost Pro is not displayed on the Webpage. If you need to confirm the software version information of Schneider Boost Pro, you can check it through the HMI of Schneider Boost Pro.

| Number | Step   | Interface |
|--------|--|-----------|
| 1      | Click menu on the screen and click "?" in the pop-up box on the right.   |           |
| 2      | Click "About the Version", and you can see all versions on the screen. System software logical version is the current software version of the Schneider Boost Pro. |           |

# 3 Operation and Function Description of System

## 3.6 FW Upgrade via OTA

- FW OTA: If you want to upgrade the firmware of Schneider Boost Pro, you can OTA in below area.

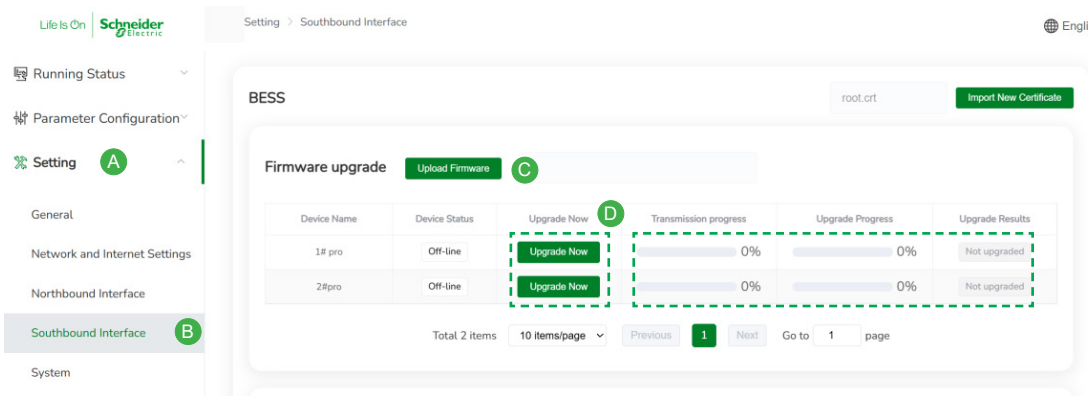

OTA steps are as follows:

- Click "Setting"→B. "Southbound Interface".
- Click "Upload Firmware",Waiting for firmware upload success.
- Click "upgrade Now",button behind the Schneider Boost Pro you want to upgrade.
- After clicking, the web page will be gray and the upgrade package is being transmitted. Wait until the transmission progress reaches 100%,Upgrade Progress reaches 100% and Upgrade results show "Upgrade succeede",It means Schneider Boost Pro Firmware upgrade is successful.

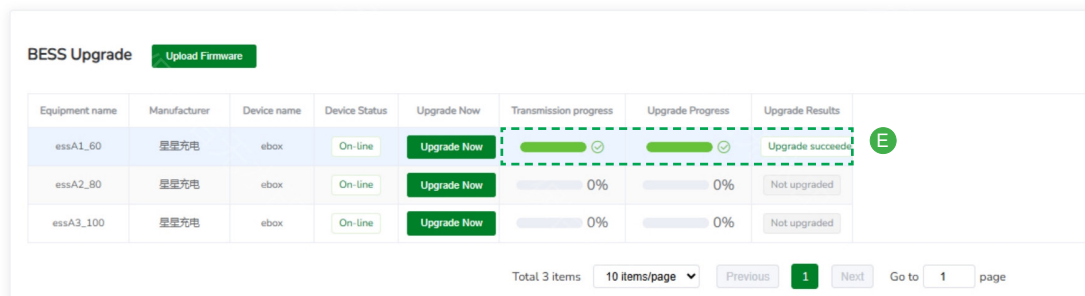

Upgrade lighting description are as follows:

| Step                       | Act on            | Lighting effects   |
|----------------------------|-------------------|--|
| Upload firmware            | Upload firmware   | Green light on, off  |
| Upgrade now (transmission) | Transfer firmware | When the green light flashes twice during transmission and the yellow light flashes quickly after transmission, it indicates that the upgrade has begun.   |
| Upgrade now (upgrade)      | Upgrade firmware  | During the upgrade, the yellow light flashes quickly, and after the upgrade is completed, the green light flashes twice<br>Note: Sometimes the lighting effect disappears during the upgrade, which is normal. |

## 4.1 Installation Confirmation

**⚠ DANGER****HAZARD OF ELECTRICAL SHOCK, EXPLOSION OR ARC FLASH**

- Pay attention to the positive and negative poles during wiring.
- Smoking are prohibited near the battery.
- Conforming fire-fighting facilities must be provided on site, such as fire sand and carbon dioxide fire extinguisher, etc.

**Failure to follow these instructions will result in death or serious injury.**

**⚠ WARNING****HAZARD OF ELECTRIC ARC OR FIRE**

- Tighten the fastening screws of copper bars or cables according to the torque specified in the text, regularly check whether they are tightened, whether there are rust, corrosion or other foreign objects, and clean them up.
- Please use the special protective equipment and insulation tools to avoid electric shock injuries or short-circuit faults.
- When tightening the battery connection, ensure that the terminal connection is tight and the cable is not damaged.
- When making cables, be sure to stay away from the equipment to avoid cable debris accidentally entering the equipment, causing personal injury and equipment damage due to sparking.

**Failure to follow these instructions can result in death, serious injury, or equipment damage.**

**NOTICE****RISK OF EQUIPMENT DAMAGE**

The cable colors in all electrical connection diagrams in this section are for reference only. Please select according to local cable standards.

**Failure to follow these instructions can result in equipment damage.**

**■ Cable Preparation:**

This document only describes the cable preparation models, please refer to the Schneider Boost Pro Installation and User Guide for the specific wiring process. for detail information, Please refers to chapter 6.1 Cable Preparation.

| Type                | Description   | Recommended Specification  | Cable Source            |
|---------------------|---|--|-------------------------|
| AC input cable (*)  | Grid phase L1 cable                                     | "Conductor cross-sectional area: 70mm <sup>2</sup> Rate Voltage: 0.6/1KV"  | Not included in package |
|                     | Grid phase L2 cable                                     | "Conductor cross-sectional area: 70mm <sup>2</sup> Rate Voltage: 0.6/1KV"  |                         |
|                     | Grid phase L3 cable                                     | "Conductor cross-sectional area: 70mm <sup>2</sup> Rate Voltage: 0.6/1KV"  |                         |
|                     | Grid phase N cable                                      | "Conductor cross-sectional area: 35mm <sup>2</sup> Rate Voltage: 0.6/1KV"  |                         |
|                     | PE cable  | "Single copper core cable,<br>Conductor cross-sectional area: 35mm <sup>2</sup> Rate Voltage: 0.6/1KV"                       |                         |
| Communication cable | EcoStruxure Energy Asset Controller communication cable | "Outdoor twisted pair multi-core shielded wire, Conductor cross-sectional area: 0.2 mm <sup>2</sup> to 0.5 mm <sup>2</sup> " |                         |

\* Recommended: N2XBY, With VDE 0276, IEC 60502-1.

**■ System grounding instructions:**

| Inbound line description            | Recommended cable model mm for incoming line2(Recommended copper core)   |
|-------------------------------------|--|
| System grounding method description | Grid connection mode: The system supports the power supply system of municipal power distribution network as TN-S, TN-C and TN-C-S. The PE protection line and N line of the system are both led out from the low-voltage side distribution system of the transformer; |

# 4 Preparation and Inspection Before System Commissioning

## 4.2 Communication Connection

### 4.2.1 Schneider Boost Pro

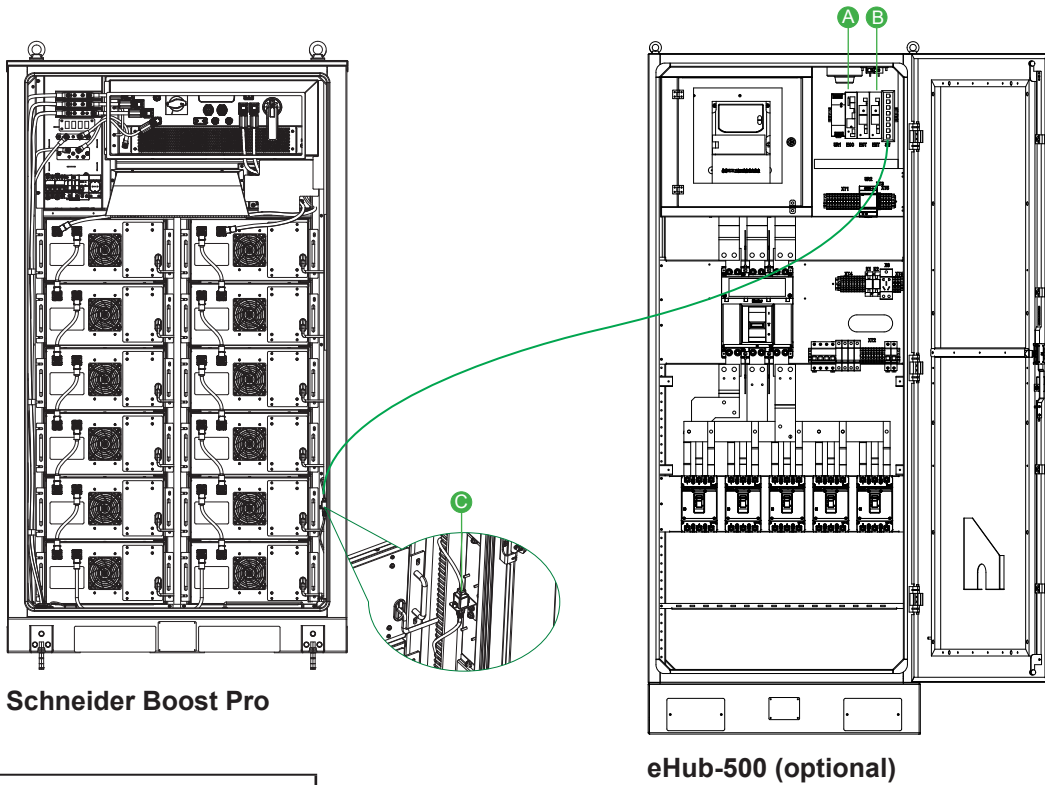

|   |  |
|---|--|
| A | EcoStruxure Energy Asset Controller        |
| B | 8-Port Network switch                      |
| C | Schneider Boost Pro cabinet RJ45 connector |

- Multiple Schneider Boost Pros are connected to the switch, 8port network switch is then connected to EcoStruxure Energy Asset Controller.
- The switch is installed in the ehub-500 cabinet.

### 4.2.2 Power Meter

485 Communication is used to establish communication connection between the meter (gate meter, Schneider Boost Pro meter) and EcoStruxure Energy Asset Controller. 1A1B is a set of communication ports, which need to be occupied in actual use.

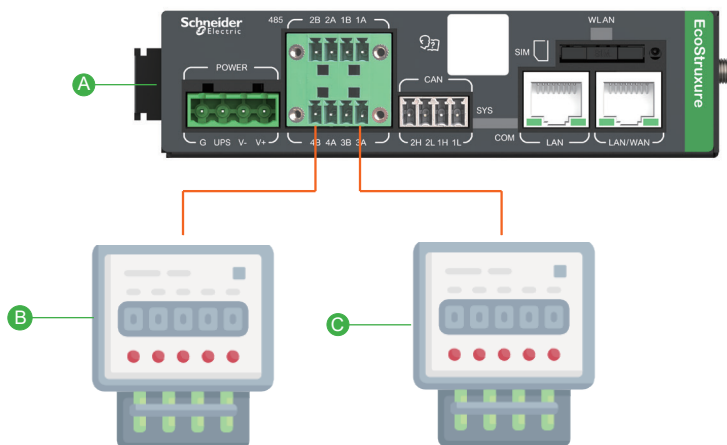

|   |                                     |
|---|-------------------------------------|
| A | EcoStruxure Energy Asset Controller |
| B | Gateway meter                       |
| C | BESS meter                          |

#### Note :

- When establishing the channel, it is necessary to pay attention to which port of RS485 the gateway meter and Schneider Boost Pro meter are connected to, which is a sufficient and necessary condition for local webpage commissioning and online.
  - The figure below shows how to identify the port number. In the actual field environment, RS485 is a shielded twisted pair communication line, which needs to be connected to both AB ports.
- BESS meter is connected to the EcoStruxure Energy Asset Controller through the RS485 communication line. According to the local magnification diagram and the meter connection line, the communication line of the Schneider Boost Pro meter is connected to port 3 at present. Therefore, when establishing the communication topology later, port 3 needs to be selected.
  - Gateway meter at the gate is connected to the EcoStruxure Energy Asset Controller through the RS485 communication line. As can be seen from the local enlarged diagram and the connection line of the gate meter, the communication line of the current gate meter is connected to port 4. Therefore, when establishing the communication topology later, port 4 needs to be selected.

## 4.3 Power on the System

## 4.3.1 Pre-energization Checks

**⚠ WARNING****HAZARDS EXIST IN FAILING TO INSPECT THE SCHEIDER BOOST PRO BEFORE ENERGIZATION**

- Ensure the reliability of the equipment by inspecting the Schneider Boost Pro before energization to confirm the absence of damage, secure connections, grounding, cable insulation, cabinet doors, and no foreign objects inside.
- Ensure the external AC main circuit breaker (feeding into our cabinet) is switched ON. Once power is supplied, our system will then be able to detect and measure the voltage.
- Ensure the reliability of the electrical system by having a qualified technician complete the Pre-energization checklist and verify adherence to all applicable local electrical codes and regulations.

**Failure to follow these instructions can result in death or serious injury.**

| No. | Item   | Description  |
|-----|--|--|
| 1   | Schneider Boost Pro appearance                         | <ul style="list-style-type: none"> <li>■ <b>Visual Condition Check:</b> <ul style="list-style-type: none"> <li>- Verify the equipment casing is free of damage, with intact paint finish (no peeling, flaking, or rust).</li> <li>- Inspect for physical deformations, cracks, or signs of overheating.</li> </ul> </li> <li>■ <b>Label Verification:</b> <ul style="list-style-type: none"> <li>- Ensure all safety labels, ratings, and warning signs are legible and securely affixed.</li> <li>- Replace any damaged or faded labels immediately using approved replacements.</li> </ul> </li> </ul> |
| 2   | Cable appearance                                       | <ul style="list-style-type: none"> <li>■ <b>Cable Jacket Integrity:</b> <ul style="list-style-type: none"> <li>- Inspect for cuts, abrasions, swelling, or discoloration.</li> <li>- Verify no exposure of internal conductors or shielding.</li> </ul> </li> <li>■ <b>Conduit &amp; Protection System:</b> <ul style="list-style-type: none"> <li>- Ensure protective pipes are free of dents, corrosion, or mechanical damage.</li> <li>- Confirm secure mounting and continuity of grounding conductors.</li> </ul> </li> </ul>   |
| 3   | Cable connection                                       | <ul style="list-style-type: none"> <li>■ <b>Verify that cable termination points align with design specifications.</b></li> <li>■ <b>Ensure terminal crimping strictly follows prescribed procedures, with terminals securely fastened.</b></li> <li>■ <b>Confirm cable labels (on both ends) are legible and oriented uniformly.</b></li> </ul>   |
| 4   | Input voltage  | <ul style="list-style-type: none"> <li>■ <b>AC 230/400V.</b></li> </ul>  |
| 5   | MCB, MCCB, DC isolation switch and other switch device | <ul style="list-style-type: none"> <li>■ <b>All are set to "OFF" status.</b></li> </ul>  |

# 4 Preparation and Inspection Before System Commissioning

## 4.3 Power on the System

### 4.3.2 Power on the System

The system is powered on in accordance with the top-down power-on sequence. The main switch is closed first, followed by the gradual closing of each branch switch, and finally the Schneider Boost Pro cabinet is powered on. The following table shows the power-on sequence

| Number | Assignment                                   | Power on operation  |
|--------|--|---|
| 1      | EcoStruxure Energy Asset Controller power on | Close the EcoStruxure Energy Asset Controller power supply switch on the side of the distribution facility.         |
| 2      | The switch is powered on                     | Close the power supply switch of the switch on the side of the distribution facility.                               |
| 3      | EHUB-500 is powered on                       | Close the main switch above the ehub-500 cabinet first, and then close each Schneider Boost Pro power supply switch |

When the upstream Ehub-500 circuit breaker of the energy storage system is closed, it indicates that the system is energized. The detailed power-on procedure for the energy storage system is described below.

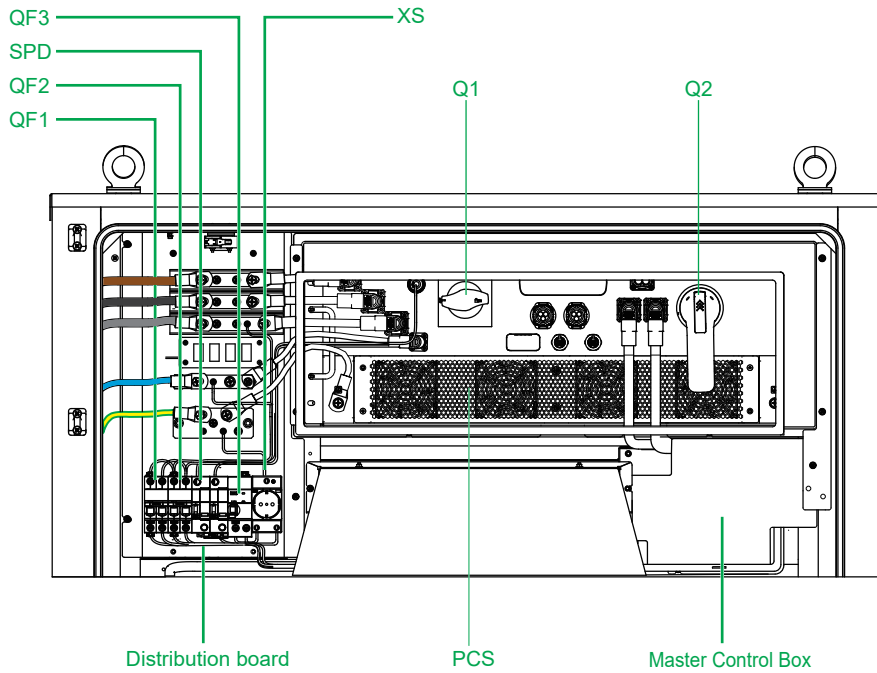

| Switch label | Equipment          | Switch definition   |
|--------------|--------------------|---|
| Q1           | PCS                | MCCB  |
| Q2           | PCS                | DC isolation switch   |
| QF1          | Distribution board | MCB for Auxiliary power   |
| QF2          | Distribution board | MCB for Air conditioning  |
| SPD          | Distribution board | Surge Protective Device (integrated with MCB)                       |
| QF3          | Distribution board | RCBO (Residual Current Circuit Breaker with Overcurrent Protection) |
| XS           | Distribution board | Socket outlet   |

# 4 Preparation and Inspection Before System Commissioning

## 4.3 Power on the System

- |               |  |
|---------------|--|
| <b>Step 1</b> | Grid-side input check and energize the PCS DC side by closing DC isolation switch Q2 |
| <b>Step 2</b> | Energize the SPD by closing its integrated MCCB                                      |
| <b>Step 3</b> | Energize the PCS AC side by closing MCCB Q1  |
| <b>Step 4</b> | Energize the master control box by closing MCB QF1                                   |
| <b>Step 5</b> | Energize the air condition by closing MCB QF2  |
| <b>Step 6</b> | Energize the socket by closing RCBO QF3  |
| <b>Step 7</b> | Check after power up   |

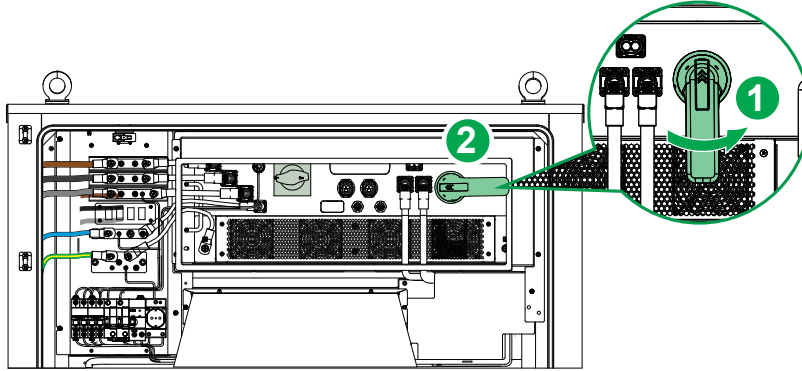

### Step 1: Grid-side input check

- Check that external AC power is available and supplied to the cabinet. Once power is supplied, our system will then be able to detect and measure voltage.
- Verify that the line voltage is 400 V.
- Power on the PCS DC side by closing DC isolation switch Q2.

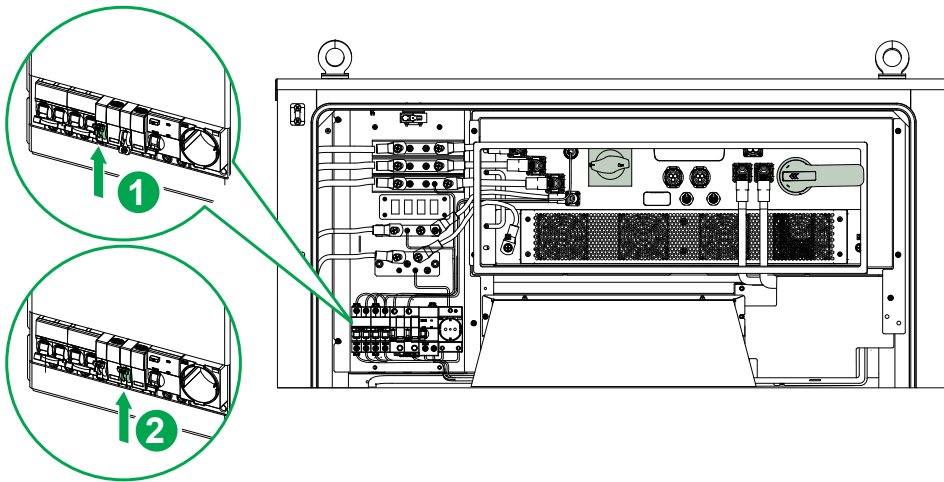

### Step 2: Close the integrated MCCB to supply power to the SPD.

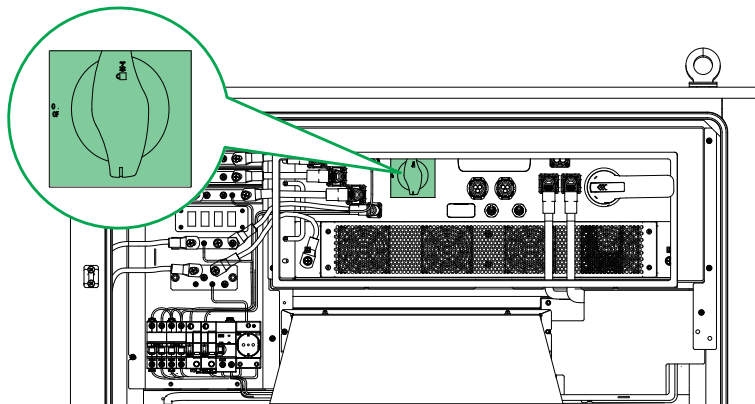

### Step 3: Close MCCB Q1 to supply power to the PCS AC side.

# 4 Preparation and Inspection Before System Commissioning

## 4.3 Power on the System

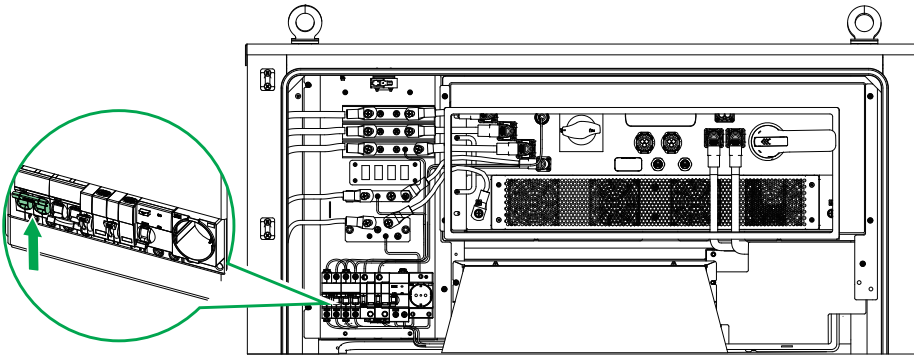

**Step 4: Close MCB QF1 to supply power to the master control box.**

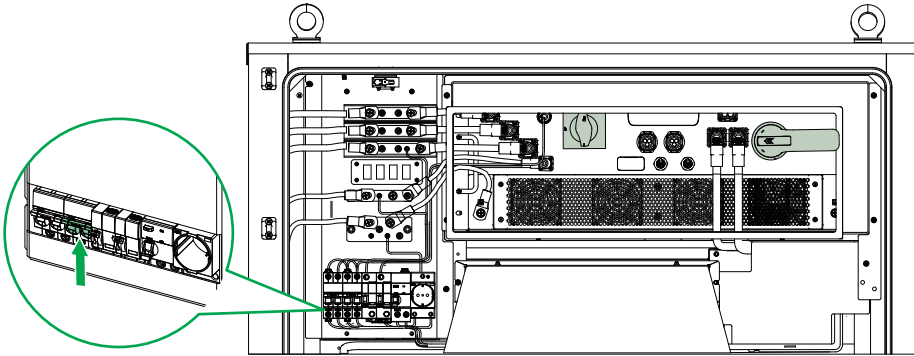

**Step 5: Close MCB QF2 to supply power to the air conditioner.**

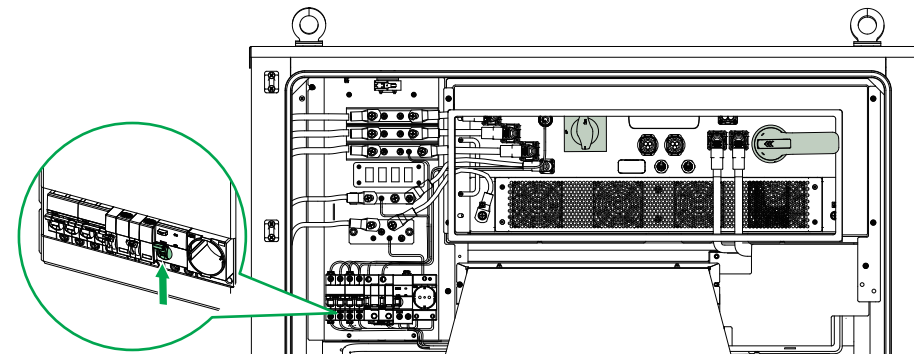

**Step 6: Close RCBO QF3 to supply power to the socket.**  
**Step 7: Check after power up**  
The system is running normally, the indicator light is green.

# 4 Preparation and Inspection Before System Commissioning

## 4.3 Power on the System

### 4.3.3 EcoStruxure Energy Asset Controller Power Supply

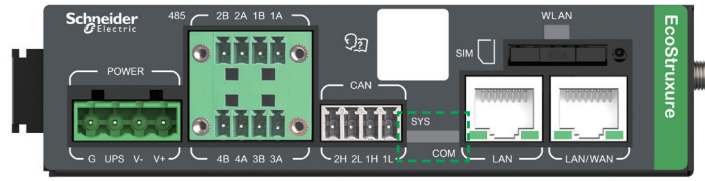

After the municipal power is connected, observe that the red light of EcoStruxure Energy Asset Controller indicator is always on, indicating that EcoStruxure Energy Asset Controllers powered on successfully. After about 2min, the red light of EcoStruxure Energy Asset Controller changes from always on to flashing, indicating that EcoStruxure Energy Asset Controller is running normally.

### 4.3.4 Modification of Mode and IP after Schneider Boost Pro is Powered on

#### NOTICE

##### RISK OF COMMUNICATION FAILURE

- The IP address modified here for the Schneider Boost Pro is the communication address provided in the EcoStruxure Energy Asset Controller webpage for establishing the communication topology between the EcoStruxure Energy Asset Controller and the Schneider Boost Pro. It is crucial to ensure the accuracy of the modification and avoid IP conflicts among multiple Schneider Boost Pro units. When there are multiple units, it is recommended to number them in sequence.
  - Adjusting Schneider Boost Pro to remote mode is a prerequisite for EcoStruxure Energy Asset Controller to control Schneider Boost Pro.
  - The Schneider Boost Pro cabinet mode commissioning follows the order of first changing the IP address and then adjusting to remote mode.
- Failure to follow these instructions can result in the system is not functional.**

| Number | Interface diagram | operate  |
|--------|-------------------|--|
| 1      |                   | <p><b>Step 1:</b> Before modifying the IP, confirm that the control mode is in local mode. The IP can only be modified in local mode, and cannot be modified in remote mode.</p> <p><b>Step 2:</b> Click Menu in the upper right corner of the screen, and the following menu bar will pop up on the right. Click parameter set.</p> |
| 2      |                   | <p><b>Step 3:</b> Enter the IP modification page as shown in the figure.</p> <p><b>Step 4:</b> Click the last IP address to modify the IP address. Click 22 here to modify the IP address.</p> <p><b>Step 5:</b> After IP modification, wait for the device to restart to check whether IP modification is successful.</p>           |

# 4 Preparation and Inspection Before System Commissioning

## 4.3 Power on the System

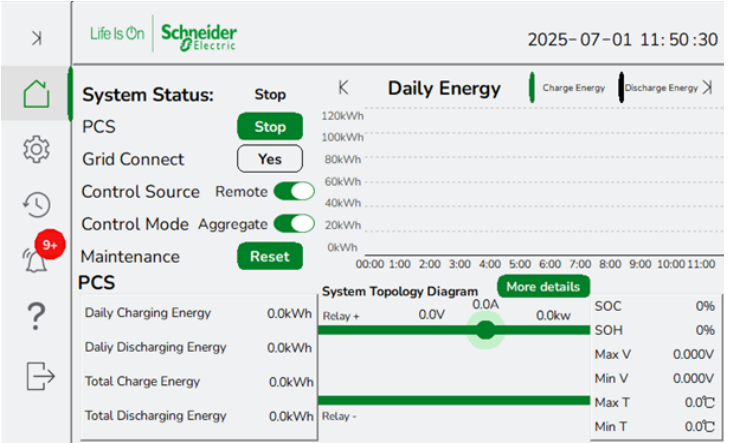
| Number | Interface diagram  | operate   |
|--------|--|---|
| 3      |  <p>The screenshot shows the Schneider Electric PCS interface. At the top, it displays 'LIFE IS ON Schneider Electric' and the date/time '2025-07-01 11:50:30'. The main section is titled 'System Status' and includes controls for 'Stop', 'Grid Connect' (Yes), 'Control Source' (Remote), and 'Control Mode' (Aggregate). Below this is a 'Daily Energy' chart showing 'Charge Energy' and 'Discharge Energy' over a 24-hour period. A 'Maintenance' section has a 'Reset' button. The bottom part of the interface shows 'PCS' statistics (Daily Charging/Discharging Energy, Total Charge/Discharge Energy) and a 'System Topology Diagram' with 'More details' link. The diagram shows 'Relay +', 'Relay -', and various parameters like SOC, SOH, Max V, Min V, Max T, and Min T.</p> | <p><b>Step 6:</b> After the IP modification is successful, you need to return to the main interface and change the control mode to Remote mode.</p> |

**NOTICE****RISK OF COMMUNICATION AND CONTROL FAILURE**

- The communication addresses in the communication topology must be consistent with the devices.
- The controlled devices and parameters in the control topology must be correctly issued.

**Failure to follow the provided instructions may result in system malfunction, preventing the customer from operating in remote mode.**

**5.1 Connect EcoStruxure Energy Asset Controller to Computer**

For more information of connecting EcoStruxure Energy Asset Controller to computer, please refer to Chapter 3.

**5.2 Log in System**

For detailed login system steps, please refer to Chapter 3.

**5.3 System Settings Checking**

Before configuring topology, you need to check the relevant configuration in the Webpage. It mainly includes checking the time zone.

Check whether the system time is in the current time zone and time under "Settings" → "General" → "Data and Time" → "Time Zone" & "System Time". If there is any difference, change the time to the current time. Otherwise, the Schneider Boost Pro will not be able to go online normally.

The screenshot shows the 'Setting > General' page. The 'Date and time' section is highlighted with a green dashed box and contains a green circle 'C'. It includes a 'Time Zone' dropdown menu and a 'System Time' field showing 'Current time: 2025-08-15 00:04:33'. Other sections include 'Historical Data Storage', 'Historical Data Export', 'EEAC Local Logs', and 'Information Security'.

**5.4 Schneider Boost Pro & EcoStruxure Energy Asset Controller Integrated System Configuration in Webpage****5.4.1 Communication Topology**

Click "Parameter Configuration" → "Communication topology" to enter the communication topology setting page. The initial structure of EcoStruxure Energy Asset Controller is displayed for the first time. There are three ports in EcoStruxure Energy Asset Controller, including:

- 4\*RS485 ports
- 2\*CAN ports
- 1\*LAN port

The screenshot shows the 'Parameter Configuration > Communication Topology' page. It features a tree diagram with 'EEAC' at the root, which branches into '485-1', '485-2', '485-3', '485-4', 'Can-1', 'Can-2', and 'Lan'. The 'Automatic Networking' option is selected. There are also buttons for 'Configuration Export', 'Configuration Import', and 'Save'.

### 5.4 Schneider Boost Pro & EcoStruxure Energy Asset Controller Integrated System Configuration in Webpage

The system contains the equipment in the table below. The communication mode of different devices is introduced in the table at the same time. When establishing the communication topology, the communication topology binding and communication topology parameters should be issued according to the communication mode of different devices.

| Device type    | Unit type           | Communication mode | Remarks   |
|----------------|---------------------|--------------------|---|
| Gateway meter  | Arcel/ADW-300       | Modbus RTU/RS485   | <ul style="list-style-type: none"> <li>The EcoStruxure Energy Asset Controller port needs to be checked, and the gateway meter is connected to which 485 port. When configuring the communication topology, the port number needs to be accurately selected to establish the communication connection.</li> <li>The gateway table is the core of EcoStruxure Energy Asset Controller anti-overcapacity and anti-backflow strategies when connected to the network, and is indispensable in a system.</li> <li>When the network is connected or disconnected, EcoStruxure Energy Asset Controller can monitor the voltage data of the gateway meter to execute the connection and disconnection strategy.</li> </ul> |
| Power meter    | Arcel/ADW-300       | Modbus RTU/RS485   | <ul style="list-style-type: none"> <li>The EcoStruxure Energy Asset Controller port needs to be checked, and the Schneider Boost Pro meter is connected to which 485 port. When configuring the communication topology, the port number needs to be accurately selected to establish the communication connection.</li> <li>The Schneider Boost Pro metering meter is only used for data statistics when it is connected to the grid, and needs to act as an off-grid gateway meter in the control topology when it is off-grid, supporting EcoStruxure Energy Asset Controller to complete the off-grid control strategy.</li> </ul>   |
| Energy storage | Schneider Boost Pro | Modbus TCP/LAN     | <ul style="list-style-type: none"> <li>The IP address of the Schneider Boost Pro cabinet needs to be confirmed. When configuring the communication topology, the communication address should be accurately filled in to establish the communication connection</li> </ul>  |

#### 5.4.1.1 Add Equipment

The system contains the equipment in the table below. The communication mode of different devices is introduced in the table at the same time. When establishing the communication topology, the communication topology binding and communication topology parameters should be issued according to the communication mode of different devices.

#### A. Add Schneider Boost Pro

**Step 1:** Click "Parameter Configuration" → "Communication topology".

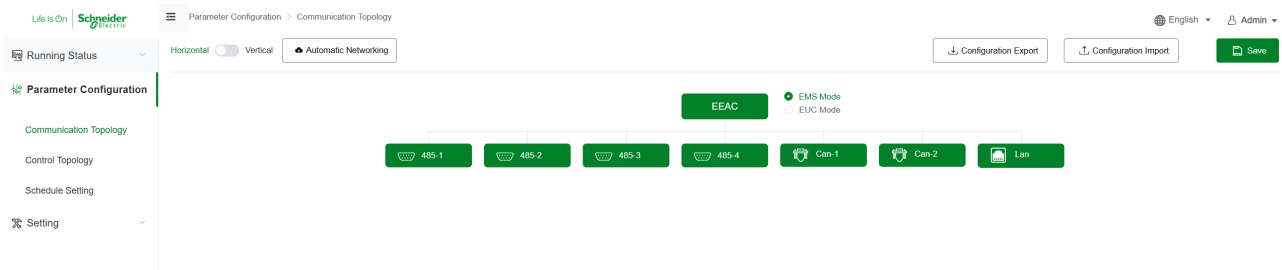

**Step 2:** Left-click the Lan port, and a new device box will pop up below.

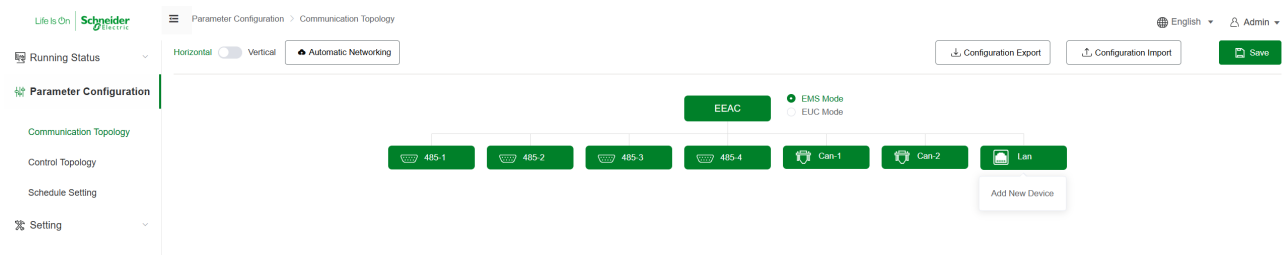

**Step 3:** Click the mouse to add a new device, and a "New Device Type" pop-up box will be displayed. In the device type pop-up box, select the device type to be bound. Select "BESS" here, click next to enter step4, and select brand and model.

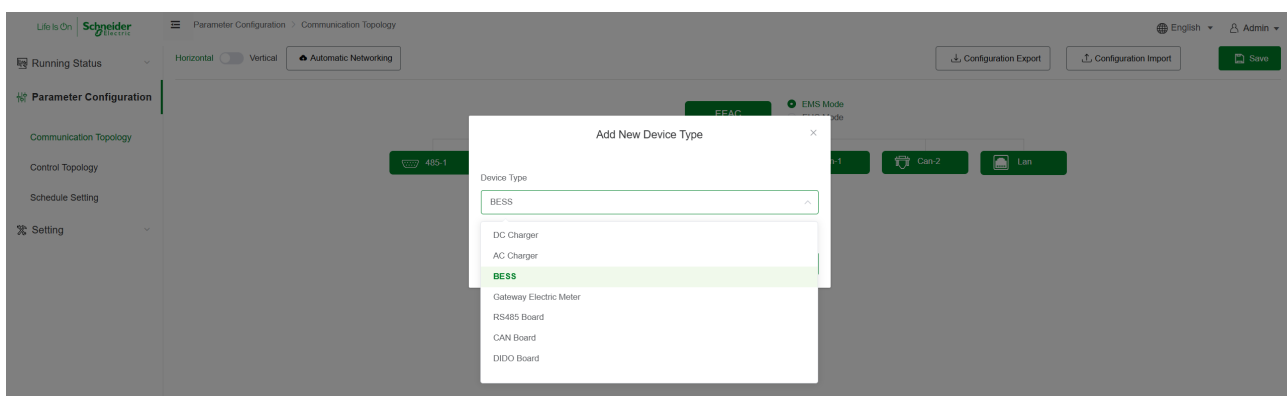

# 5

## Commissioning with EcoStruxure Energy Asset Controller Webpage

### 5.4 Schneider Boost Pro & EcoStruxure Energy Asset Controller Integrated System Configuration in Webpage

**Step 4:** Select the brand and model according to the equipment type, fill in the basic parameters of the equipment, click OK, the equipment is added successfully. Here the brand and model are Schneider /Schneider Boost Pro.

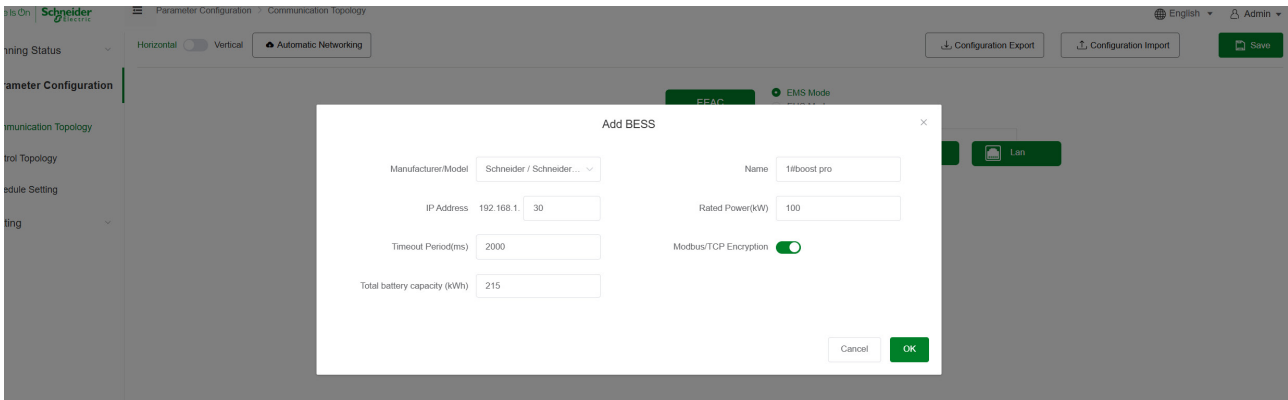

- The default value of the communication address is 1, which can be modified. The communication address here corresponds to the last bit of the IP address of each Schneider Boost Pro set in 5.3.4. For example, if the IP address is 192.168.1.30, the communication address is filled in as 30.
- Device names can be customized.
- Rated power, timeout time and total battery capacity are the default values and do not need to be modified.
- Modbus/TCP encryption switch is enabled by default.

**Step 5:** At this time, the LAN port will add the added device.

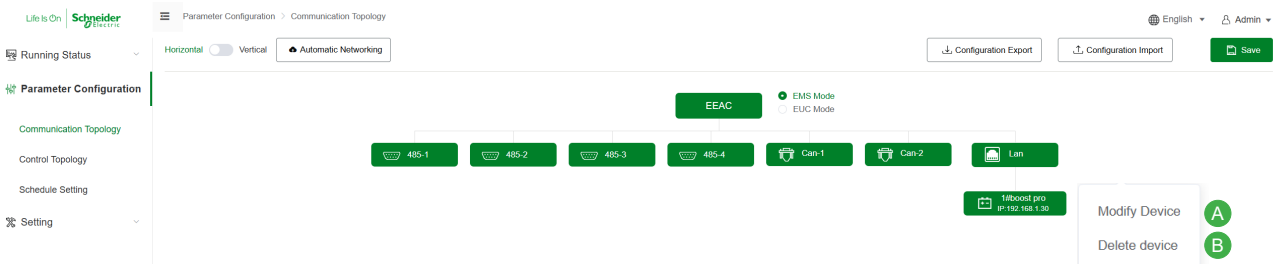

- Left-click the device box to display the "Modify Device, Delete Device" button.

A. If you need to modify the device, click Modify Device and return to step4 to modify the device parameters.

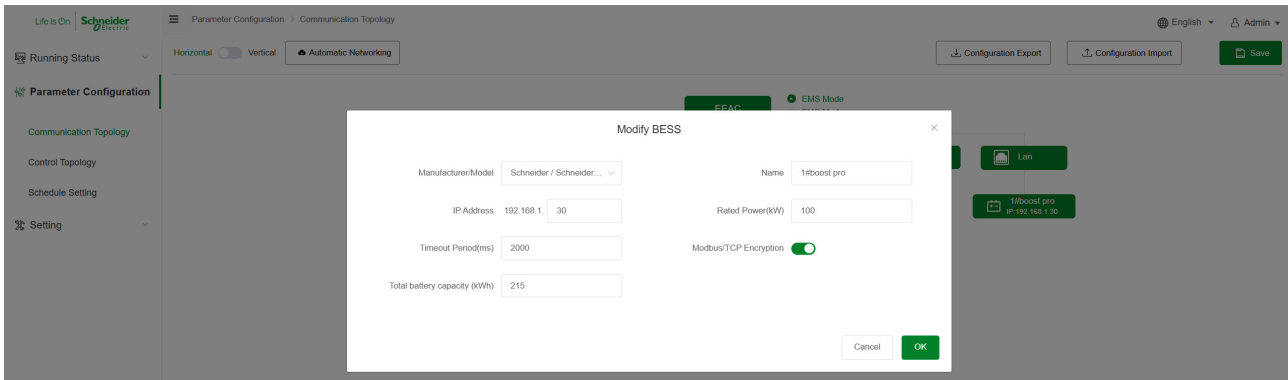

B. If you need to delete the device, click Delete Device. A pop-up box "Please confirm whether to delete the device ebox-215?" will pop up. Click OK to delete the device successfully.

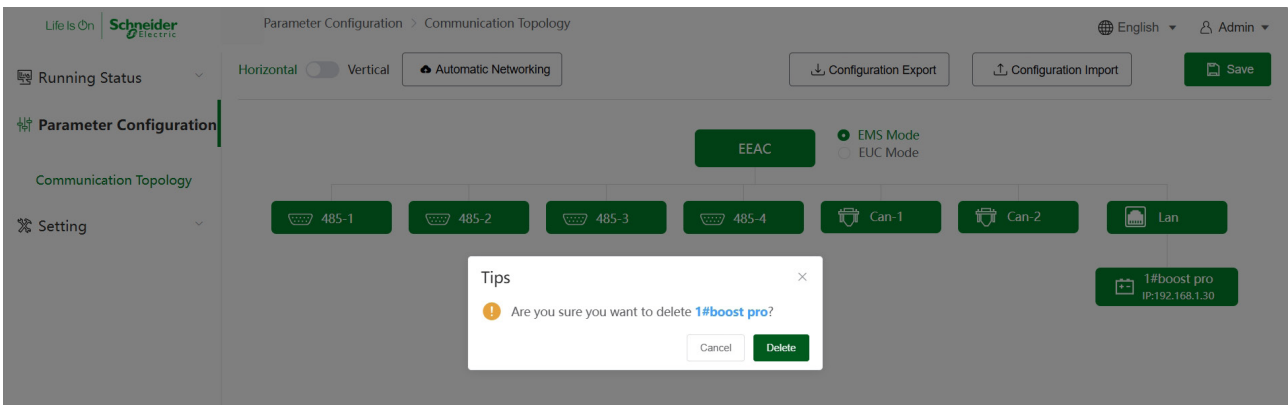

## 5.4 Schneider Boost Pro &amp; EcoStruxure Energy Asset Controller Integrated System Configuration in Webpage

## B. Add the gateway meter

The way to add the meter is the same as that to add the Schneider Boost Pro. It only needs to replace the EcoStruxure Energy Asset Controller communication topology with RS485 port for meter binding.

**Step 1:** Left-click 485-4 port, and a new device box will pop up below.

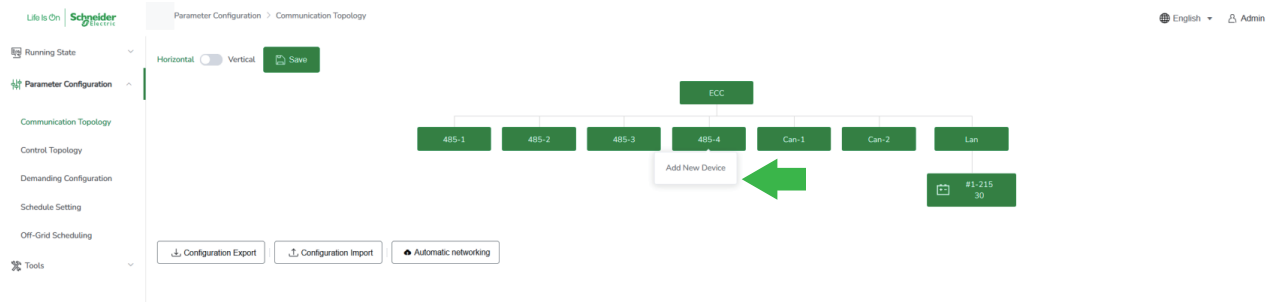

**Note:** In the previous chapter, it is introduced that the gateway meter is actually connected to port 4. Therefore, 485-4 connects the gateway meter here.

**Step 2:** Click the mouse to add a new device, and the "New Device Type" pop-up box will be displayed. In the device type pop-up box, select the device type to be bound. Here, select "Gate meter".

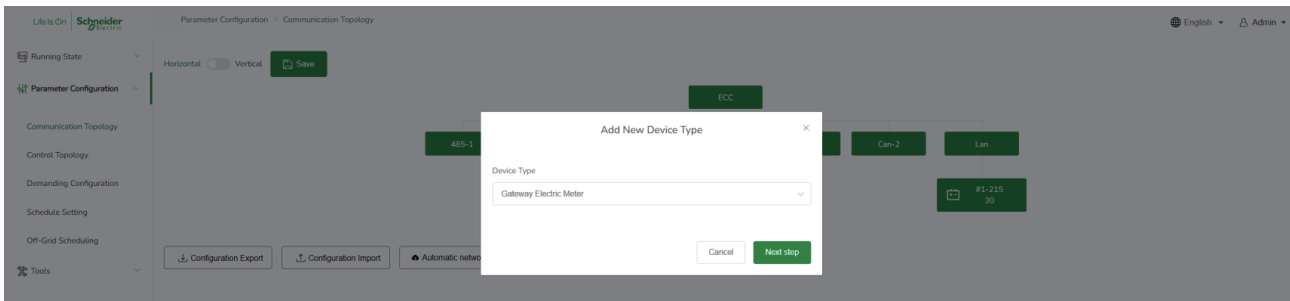

**Step 3:** Select the brand and model according to the device type. Select ADW-300 here, fill in the basic parameters of the device, click OK, and the device is successfully added.

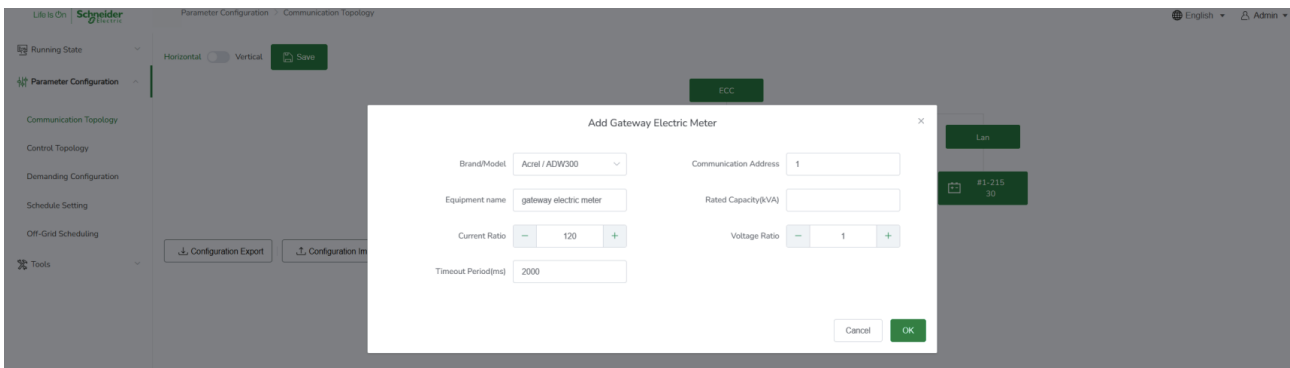

- The default mailing address is 1 and does not need to be modified. Need to confirm that the communication address of the electric meter is adjusted to 1.
- Device names can be customized.
- Rated capacity is the actual capacity of the gate meter and is filled in according to the actual environment.
- The current ratio and voltage ratio are the ratio of the meter itself, which is filled in according to the actual environment.

**Step 4:** At this time, port 485-4 will add the added gateway meter. Left-click the device box to display the "Modify device" and "Delete device" buttons.

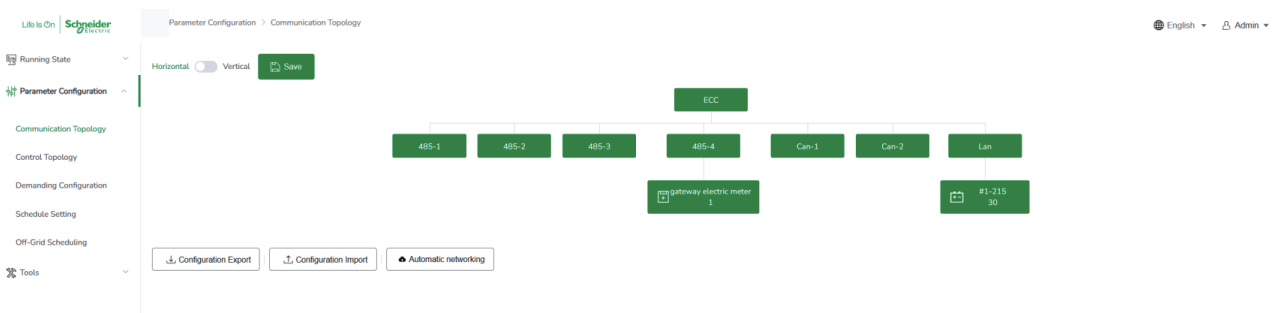

## 5.4 Schneider Boost Pro &amp; EcoStruxure Energy Asset Controller Integrated System Configuration in Webpage

## C. Add power meters

The method of adding Schneider Boost Pro meters is the same as that of B. Adding gate meters. Just pay attention to the device type and select "load meter".

**Note:** As described in the previous chapter, the Schneider Boost Pro meter is actually connected to port 3. Therefore, the 485-3 connection is used for the Schneider Boost Pro meter.

**Step 1:** Click 485-3 on the left to pop up a new device box. Select "load meter" as the device type.

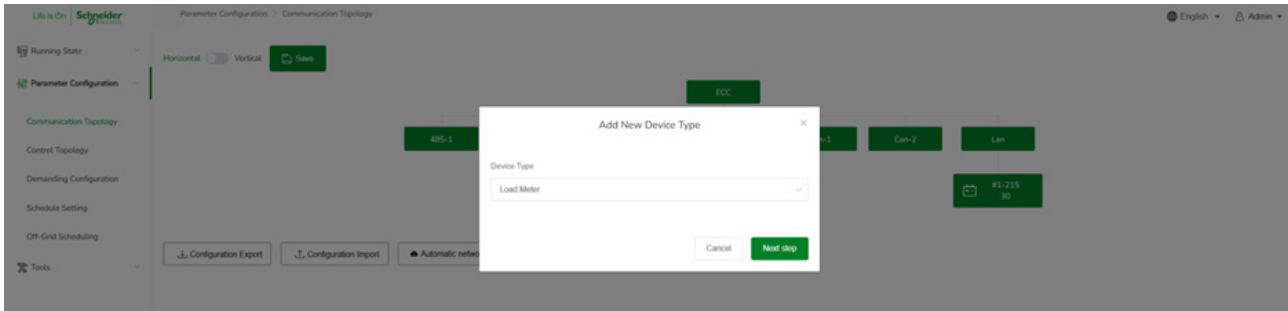

**Step 2:** Click "Next" and select the specific brand and model. The steps are the same as when adding the gate table. Click "OK" to add the Schneider Boost Pro meter successfully.

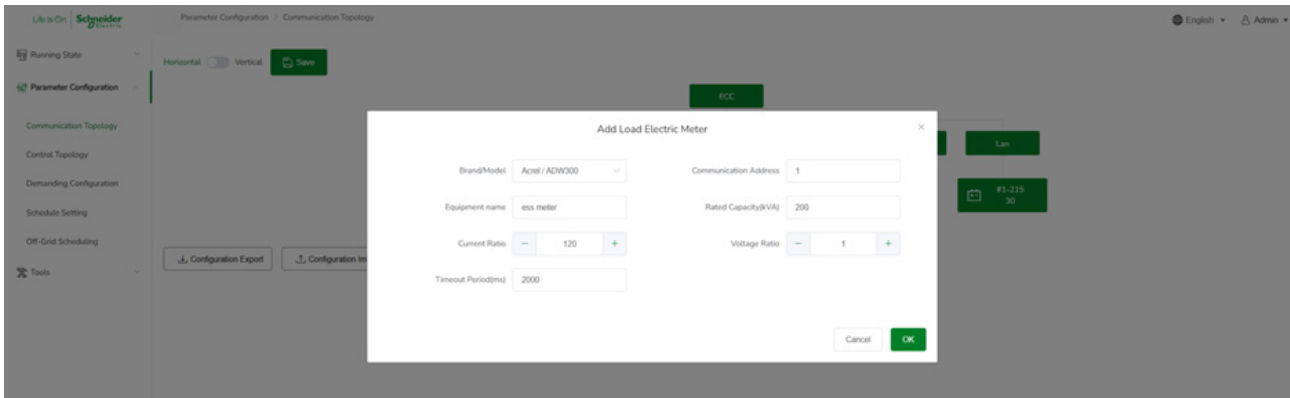

**Step 3:** At this time, the power meter has been successfully added in the communication topology.

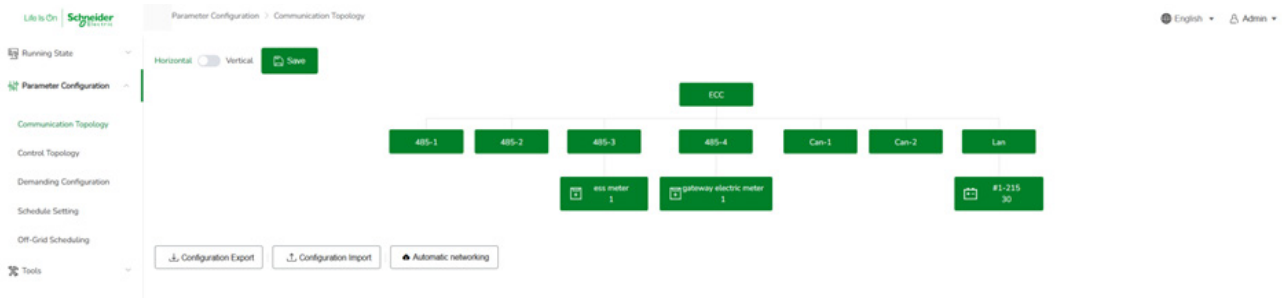

## 5.4.1.2 Parameters Save

**Step 1:** On the communication topology, click "Save" after the device has been added.

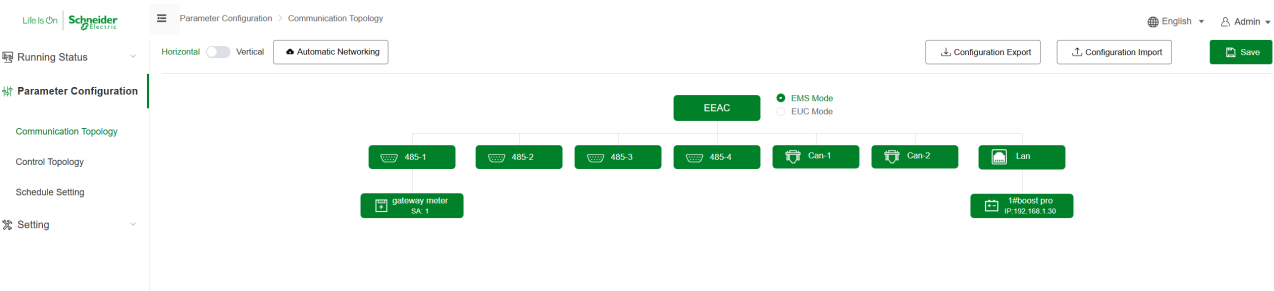

# 5

## Commissioning with EcoStruxure Energy Asset Controller Webpage

### 5.4 Schneider Boost Pro & EcoStruxure Energy Asset Controller Integrated System Configuration in Webpage

**Step 2.** Click OK to confirm the restart of EcoStruxure Energy Asset Controller. Wait for the restart of EcoStruxure Energy Asset Controller and the successful issuance of communication topology.

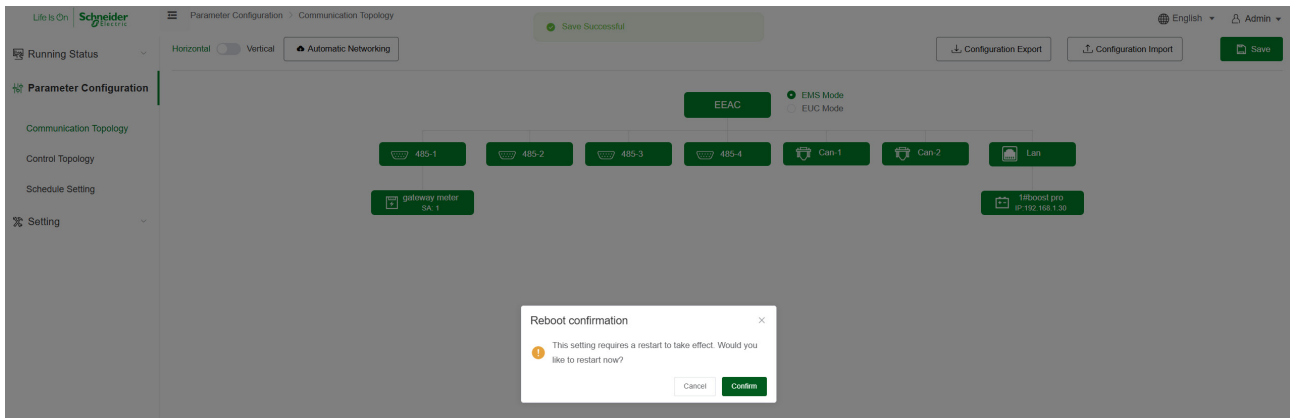

**Step 3.** Click restart, exit the web system and return to the login page. Wait about 3min to log in again.

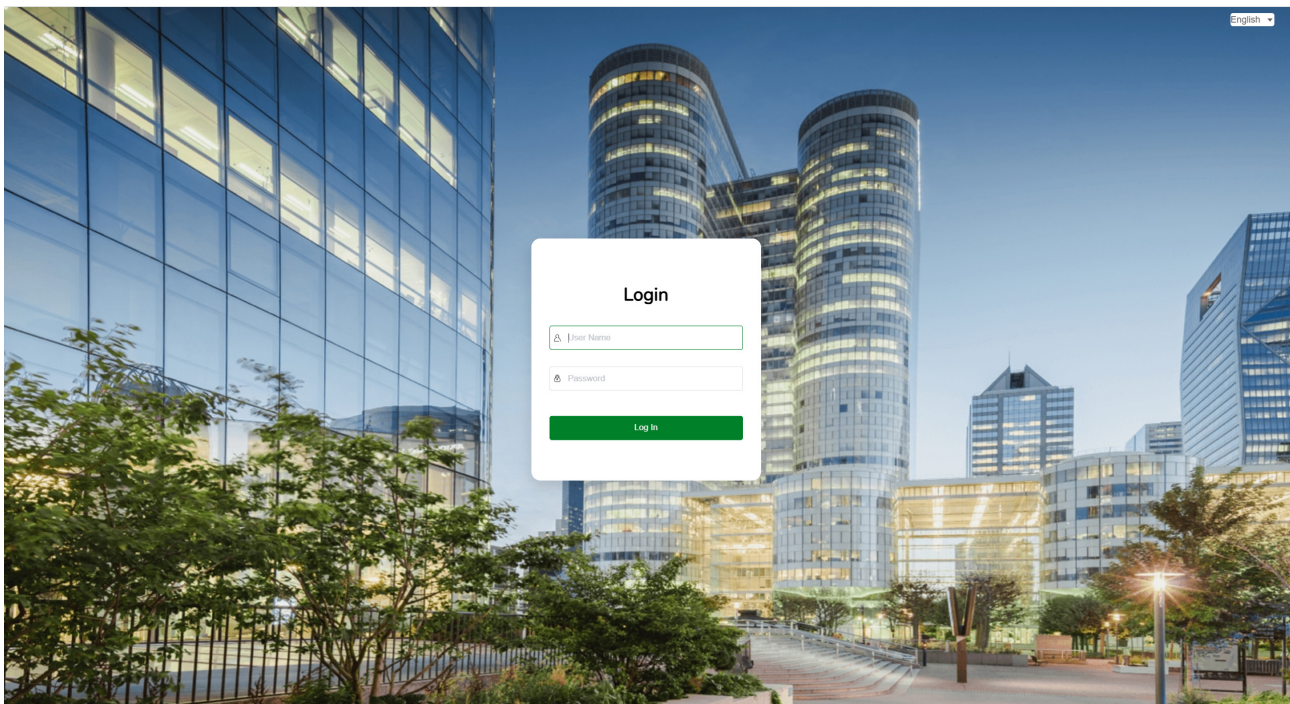

#### 5.4.2 Control Topology

### NOTICE

#### RISK OF LOSING REMOTE CONTROL OF THE SCHNEIDER BOOST PRO

The control topology is the premise of the operation of the equipment in the EEAC control system and needs to be accurately configured.

**Failure to follow the instructions may result in loss of access to Schneider Boost Pro via the web interface.**

#### 5.4.2.1 Add Controlled Devices

**Step 1:** Click "Parameter Configuration" → "Control topology", select "single layer" for hierarchical topology, and click "+" in the "Operation" column to add controlled gateway table.

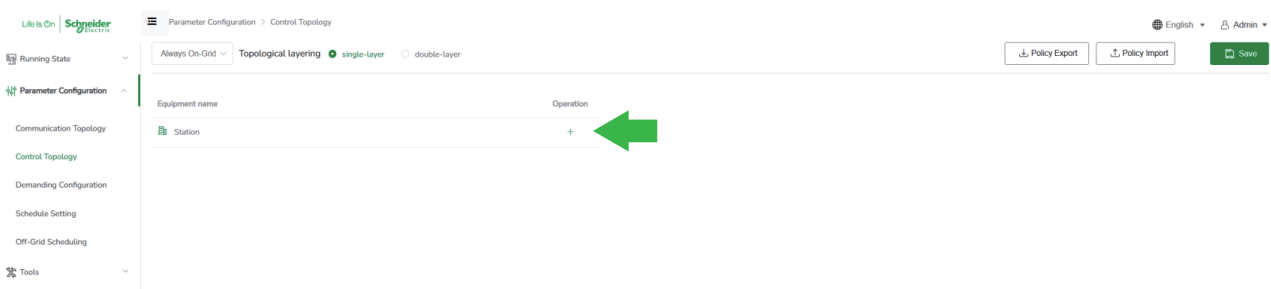

# 5

## Commissioning with EcoStruxure Energy Asset Controller Webpage

### 5.4 Schneider Boost Pro & EcoStruxure Energy Asset Controller Integrated System Configuration in Webpage

**Step 2:** Click "+" to pop up the following device adding dialog box. Select the main meter created in "communication topology", click confirm, and add the meter.

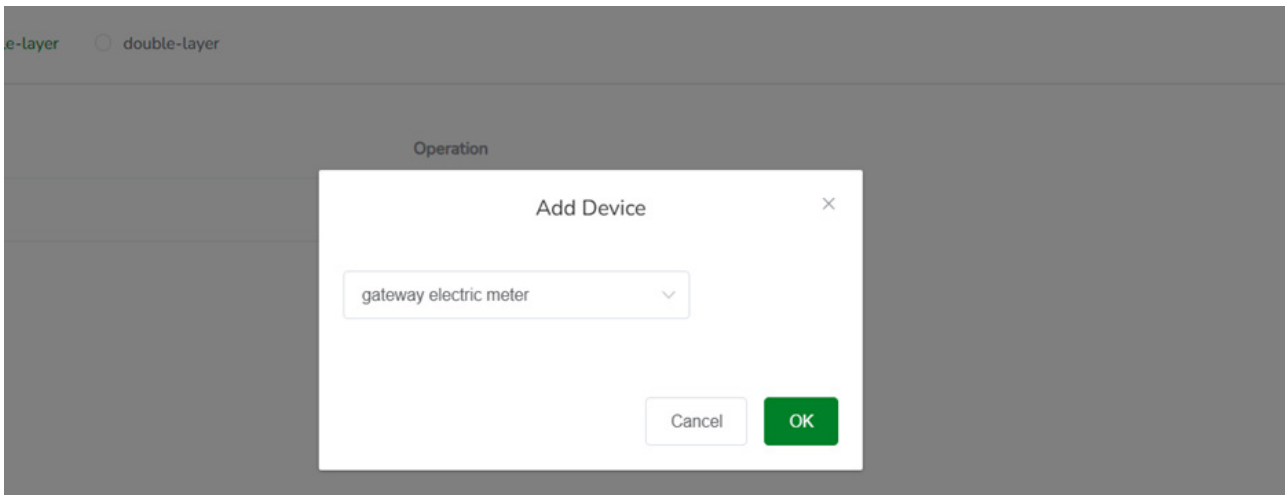

**Step 3:** After adding the gateway table, select the system operation mode and system structure in the upper left corner of the page. The system operation mode is Always On-Grid. Topology layering selects single-layer.

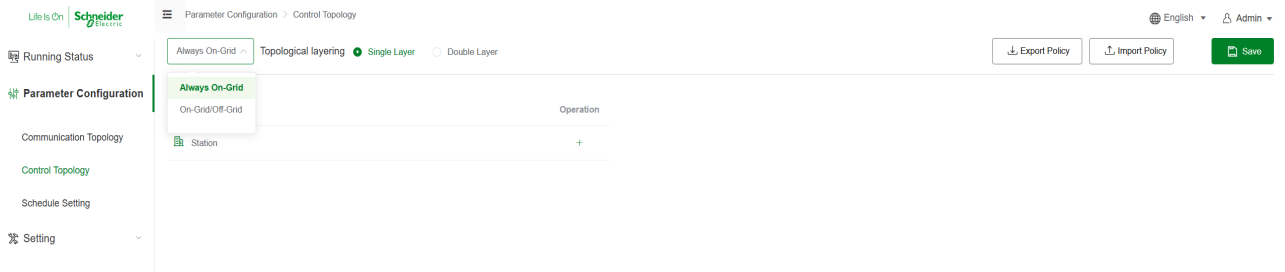

**Step 4:** After the system mode selection is completed, click "+" in the operation column of the gateway table to continue adding controlled devices.

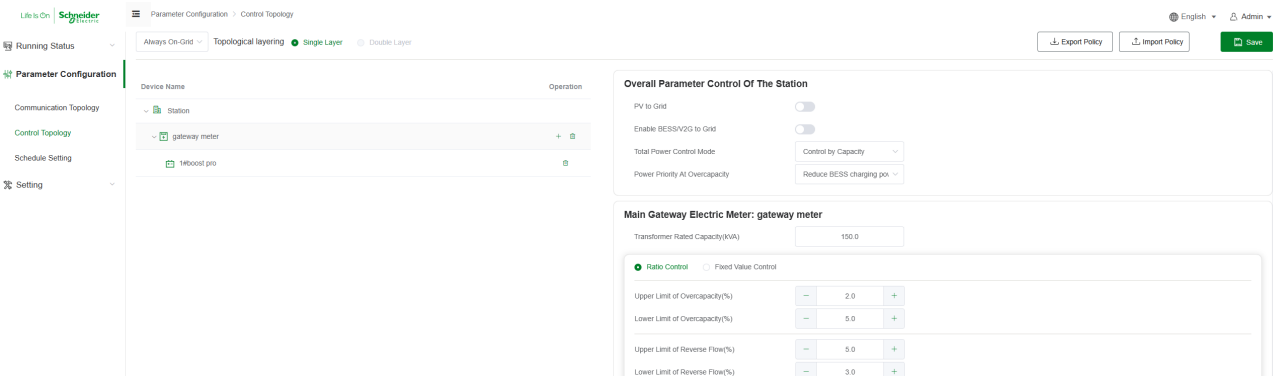

**Step 5:** Click "+" to pop up the box for adding devices. Add the Schneider Boost Pro that needs to be controlled in the system, and multiple selection is supported.

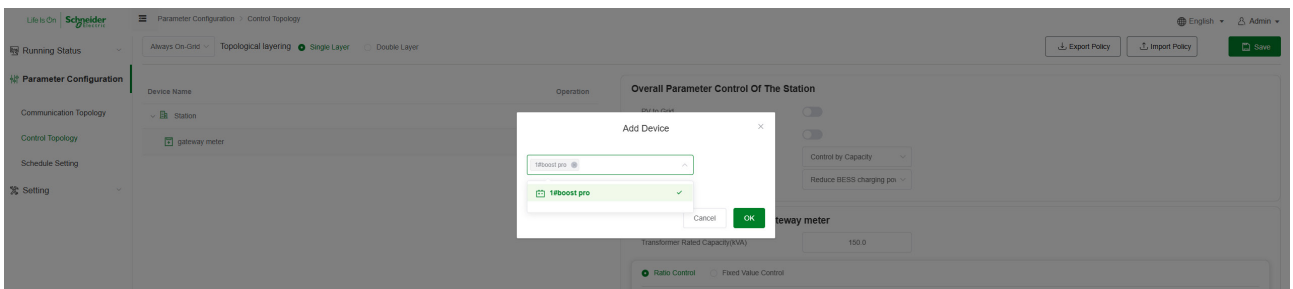

### 5.4 Schneider Boost Pro & EcoStruxure Energy Asset Controller Integrated System Configuration in Webpage

**Step 6:** Click "OK", and you can see that the controlled device on the left has been added.

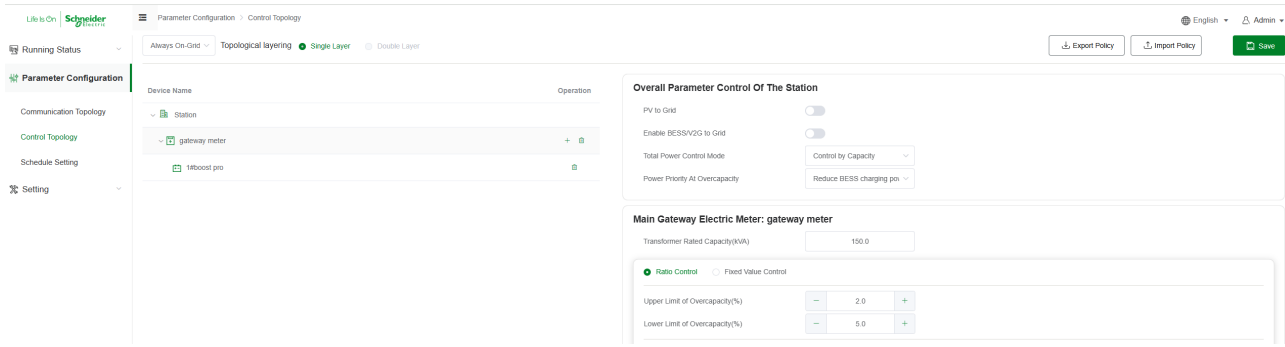

#### 5.4.2.2 Parameters Save

After the left side of the controlled device is added, the control parameters on the right side can be configured. The details of the control parameters are shown in the following table. Configure according to the steps and explanations. In general, EcoStruxure Energy Asset Controller will give the default control parameters. Click "SAVE" to send the parameters after confirming that there is no error. After the prompt "Save successful", the control parameter is successfully sent.

| Number | controlling parameter                      | explain   |
|--------|--|---|
| A      | Overall control parameters of the station  | <ul style="list-style-type: none"> <li>Allows the photovoltaic inverter to supply power to the grid, which is turned off by default.</li> <li>Allows Schneider Boost Pro to supply power to the grid, default off.</li> <li>Demand control mode, there are capacity control, static demand control, dynamic demand control.</li> <li>Power control priority is to reduce the charging power of Schneider Boost Pro first by default. It means that when the station is about to exceed the capacity, EcoStruxure Energy Asset Controller will first reduce the charging power of Schneider Boost Pro to make the station does not exceed the capacity.</li> </ul>   |
| B      | Main Gateway Electric Meter: gateway meter | <p>The total gate table is the key for EcoStruxure Energy Asset Controller to reduce overcapacity and reverse flow. It is default mode of coefficient control. Fixed value control is optional. Take the rated capacity of the gate table 150kVA as an example.</p> <p><b>a. Control of anti-super capacity</b></p> <ul style="list-style-type: none"> <li>Upper limit of overcapacity control coefficient: The difference between the upper limit of overcapacity control and the maximum allowable power value is generally set to 2%.<br/>The upper limit of the super capacity control coefficient is <math>150 * (1-2\%) = 150 * 98\% = 147\text{kW}</math>.</li> <li>Lower limit of overcapacity control coefficient: the difference between the lower limit value of overcapacity control and the maximum allowable power value, which is generally set at 5%.<br/>The lower limit of the super capacity control coefficient is <math>150 * (1-5\%) = 150 * 95\% = 142.5\text{kW}</math></li> <li>Therefore, when the system power is between 142.5 and 147, EcoStruxure Energy Asset Controller performs overcapacity control.</li> </ul> <p><b>b. Anti-backflow control</b></p> <ul style="list-style-type: none"> <li>The upper limit of reverse flow is generally set to 5%.<br/>Upper limit of reverse flow control coefficient = <math>150 * 5\% = 7.5\text{kW}</math></li> <li>The lower limit of reverse flow is generally set at 3%.<br/>The lower limit of the reverse flow control coefficient is <math>150 * 3\% = 4.5\text{kW}</math></li> <li>The EcoStruxure Energy Asset Controller representative will control the off-grid power to be maintained between from 4.5 and 7.5.</li> </ul> |
| C      | BESS Configurations                        | The Schneider Boost Pro equipment and rated power are both default values.  |

# 6

## Power off the System

The system shutdown should follow the reverse sequence of the startup process, operating from the bottom up. Therefore, in an actual environment, the power to the Schneider Boost Pro device should be disconnected first, followed by shutting down the connected ehub-500 device, and finally cutting off the main switch power supply. The shutdown sequence is as follows:

### NOTICE

#### HAZARD OF EQUIPMENT DAMAGE

A qualified technician shall execute de-energization operations.

**Failure to follow these instructions can result in equipment damage or incorrect operation.**

**Step 1:** In remote mode, ensure the Schneider Boost Pro is in standby status. If the Schneider Boost Pro is charging or discharging, log in to the webpage to set the energy storage control to "Idle". The configuration method has been detailed in Chapter 3.

**Step 2:** On the home **A** interface, if the control source displays "Remote" **B**, confirm **C** to switch it to "Local" **D** mode by following the steps in the left panel before proceeding.

# 6

## Power off the System

**Step 3:** De-energize the socket by opening RCBO QF3.

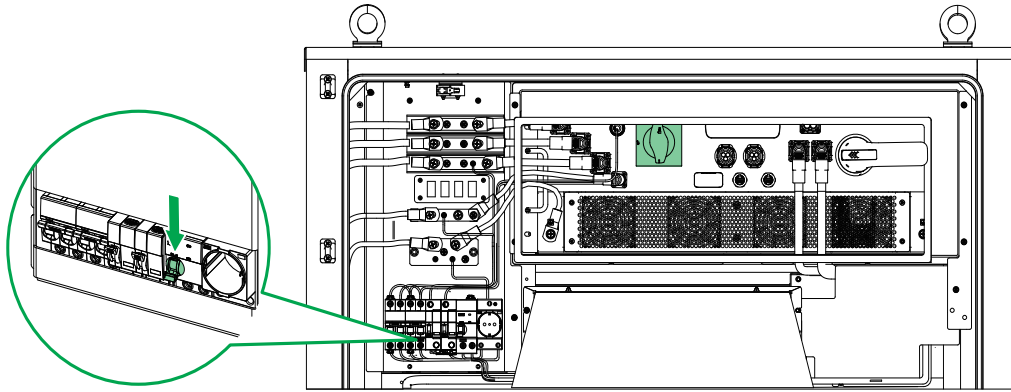

**Step 4:** De-energize the air condition by opening MCB QF2.

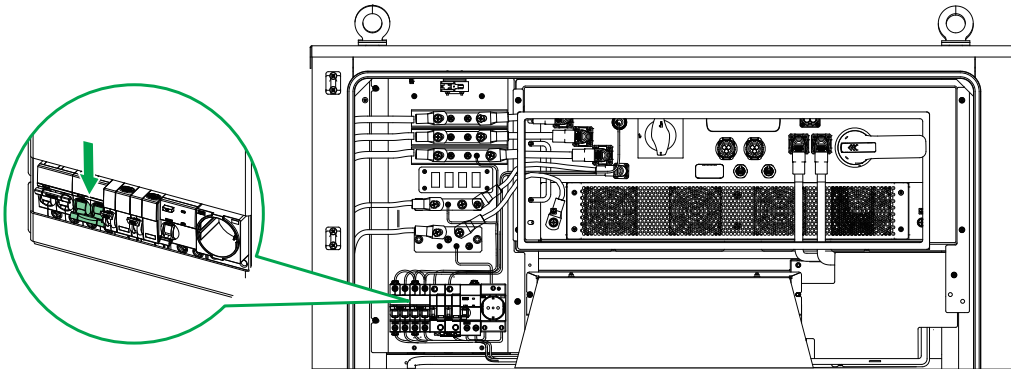

**Step 5:** De-energize the master control box by opening MCB QF1.

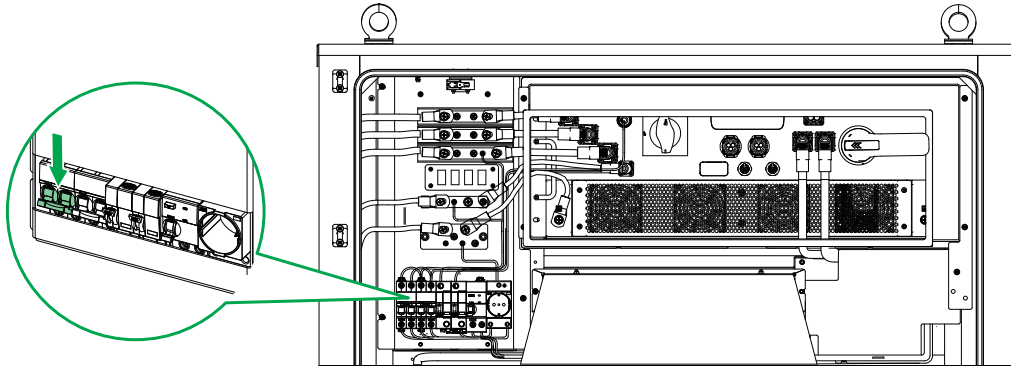

**Step 6:** De-energize the SPD integrated with MCB.

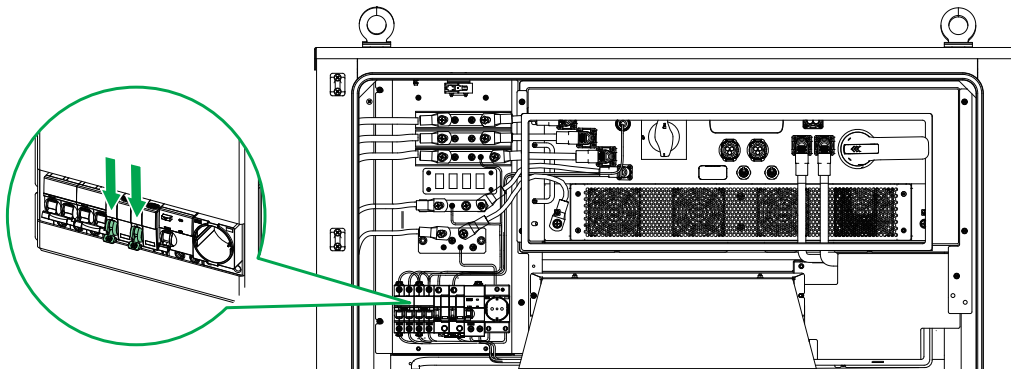

# 6

## Power off the System

**Step 7:** De-energize the PCS AC side by opening MCCB Q1.

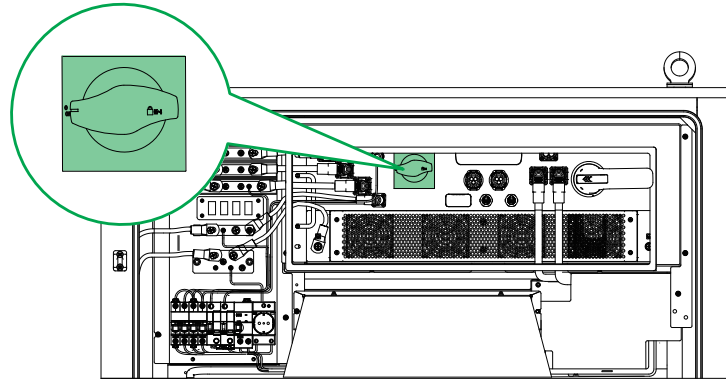

**Step 8:** De-energize the PCS DC side by opening DC isolation switch Q2.

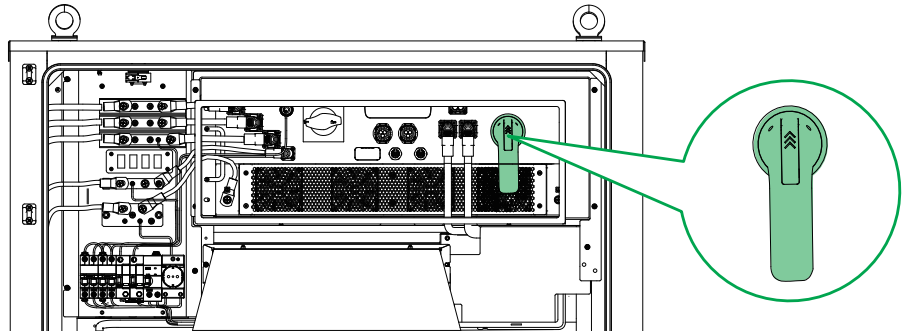

**Step 9:** In the Control Mode interface, navigate to the Aggregate Capacity tab **A** to disable Auxiliary Power **D**, then disconnect the device by following Chapter 9 instructions.

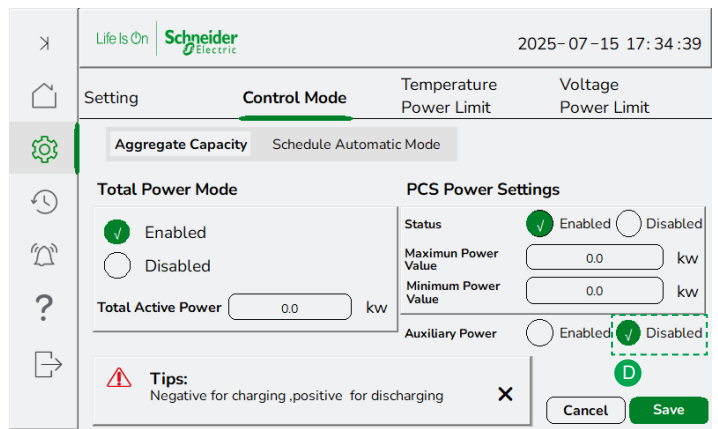
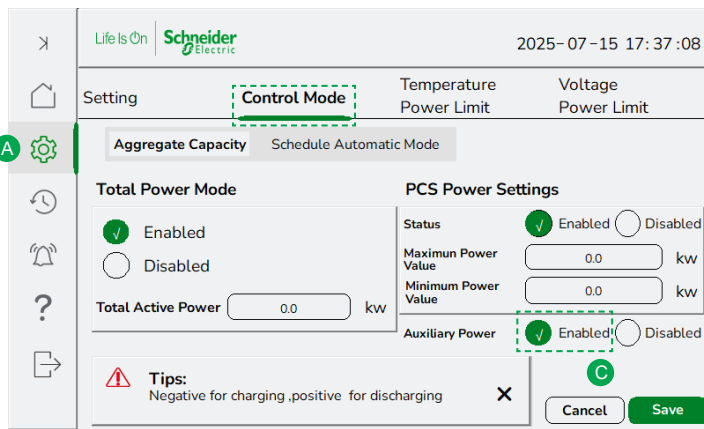

On the main screen, click the "Settings" icon, then select "Control mode." At this point, "Auxiliary Power" is set to "Enable." Click the circle in front of "Disable" to switch it to "Disable." The screen will then turn off, and the Schneider Boost Pro will completely power down.

The above steps 1 to 9 constitute the power-off operation for the Schneider Boost Pro. If it is necessary to disconnect the upstream distribution cabinet, please cut off the power supply according to the actual situation. Due to the difference in power environments between the test setup and the actual field conditions, this aspect will not be further elaborated here.

| Problems   | Solutions   |
|--|---|
| After entering 192.168.1.136, unable to access the Webpage.  | Check whether the computer being used contains 192.168.1.x. If not, it needs to be added in Network - Change Adapter Settings. After adding, re-enter the Webpage.  |
| After the webpage communication topology is issued, Schneider Boost Pro is not online.   | <p>Check whether the IP address on the Schneider Boost Pro HMI screen and the EcoStruxure Energy Asset Controller IP address are on the same network segment.</p> <p>Case 1: If they are on the same network segment, verify whether the IP address on the Schneider Boost Pro HMI screen matches the Schneider Boost Pro IP address added in the Webpage communication topology.</p> <p>Case 2: If they are not on the same network segment, it is recommended to modify the IP address of either side to ensure both are on the same network segment.</p> <p>Open the command prompt by entering "CMD" on the computer, then ping the IP addresses of EcoStruxure Energy Asset Controller and Schneider Boost Pro. If either side fails to ping, try replacing the network cable and retesting.</p> <p>Note: After completing steps 1.2, if the device still cannot go online, contact the developer Homo sapiens for further troubleshooting..</p> |
| After the webpage communication topology is issued, the meter is offline.  | Check the parameter settings on the electricity meter to ensure they are consistent with the communication topology. Mainly verify the following parameters: communication address (default is usually 1) and baud rate (9600).   |
| Instances where Schneider Boost Pro suddenly disconnects from EcoStruxure Energy Asset Controller.   | <ol style="list-style-type: none"> <li>1. Wait a few minutes to check if it recovers automatically.</li> <li>2. If not recovered, switch the Schneider Boost Pro HMI's remote mode to local mode, then change it back to remote mode again, and observe whether the connection is restored.</li> </ol>  |
| Deviation detected in electricity meter monitoring data  | Check whether the voltage ratio and current ratio of the electricity meter in the communication topology are consistent with the settings of the electricity meter and the transformer.   |
| Schneider Boost Pro is operating normally online, but does not respond after the webpage issues the Scheduling of Schneider Boost Pro command. | Schneider Boost Pro is operating normally online, but does not respond after the webpage issues the Scheduling of Schneider Boost Pro command.  |